



Date: 30.04.2013

Model: Elise/Exige & Evora fitted with Bosch ESP8 brake modules

Number: 2013/04

Copy files should be maintained by:

Service Manager		Service Reception		Supervisor		Parts Manager	
-----------------	--	-------------------	--	------------	--	---------------	--

TITLE:

Generation of C0460 Pressure sensor failure fault code.

REASON:

Instances of ABS (Anti-Lock Braking System) tell tale lamp illumination accompanied with fault code C0460 (pressure sensor failure) have been reported back to Lotus Cars.

Although the pressure sensor located within the ABS module is non-serviceable; another potential cause of this problem is the brake light switch plunger being incorrectly set.

The switch has 3 settings (as shown below), the correct setting of the brake light switch plunger results in the switches internal contacts closing at the correct time in relation to the brake pedal travel exerted by the driver.

Pedal effort/travel position	Switch Stage	Action
No pedal effort - no pedal travel	Off	Cruise control available (if required).
Initial/light pedal effort - minor pedal travel	1st Stage	Cruise control cancelled (if activated).
Light/moderate pedal effort - increased pedal travel	2nd Stage	Brake lights illuminated coinciding with an ABS module brake fluid line pressure reading of between 2 - 6 Bar.

Incorrect setting of the switch plunger will result in the ABS brake line pressure being too high at the time of brake light activation, thus generating a fault code and illuminating the ABS or Service tell tale lamp.

ACTION:

In the event that any Lotus vehicle fitted with a Bosch ESP8 module displays fault code(s) C0460 or P0571 (Cruise Control/Brake Switch A Circuit) when the ABS or Engine Management Systems are investigated using Lotus TechCentre, then the operation and setting of the brake light switch should be checked in the first instance to eliminate it as a potential cause of failure before unnecessarily renewing the ABS module or investigating other potential causes of cruise control failure.

Checking Switch operation

1. With TechCentre connected to the vehicle and ignition on select ABS brakes>Live Data:
2. From the 'Available Items' table, select:
 - Brake light switch (03).
 - Brake switch.

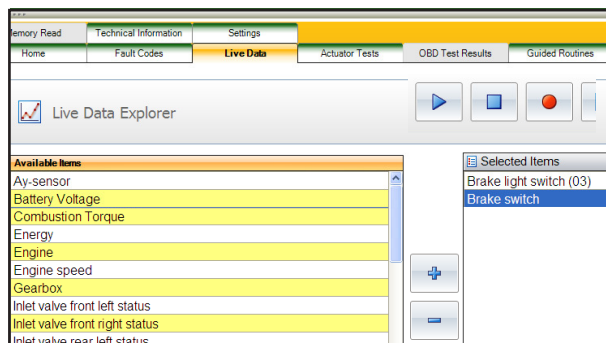

3. From within the driver's footwell area, rotate the brake light switch 90° counter-clockwise within its mounting bracket and withdraw (with the harness connector still attached to the switch).

4. Gently push the brake light switch plunger inwards towards the housing until light resistance is met, select the 'play' option from Lotus TechCentre and then gently release the plunger whilst examining the readings shown on the live data screen.

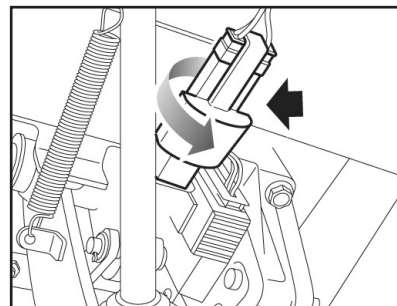

If the switch is operating correctly then the TechCentre live data readings should change in this order:

- Brake switch: (1st stage) - Actuated
- Brake Light Switch (03): (2nd stage) - Actuated

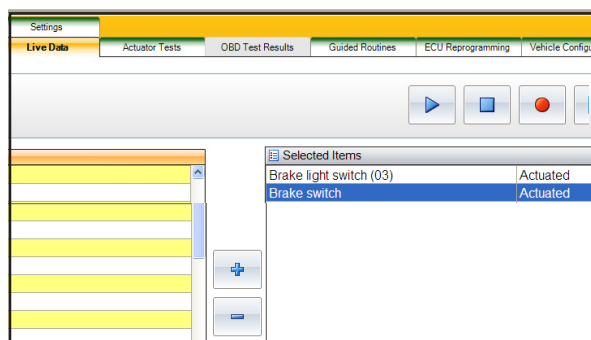

Switch operation correct:

If moving the switch plunger produces the correct readings then it should be adjusted and refitted to the vehicle so it can be retested in situ, see adjustment procedure below.

Switch operation incorrect:

If the correct readings cannot be displayed then the brake switch should be replaced, operation of the new switch checked (as above) before adjusting and fitting on the vehicle.

Plunger adjustment

Reason:

The plunger uses an internal ratchet mechanism which can be adjusted to suit the vehicle allowing for any brake pedal travel tolerance thus ensuring the correct phasing of the internal switch contacts in relation to the switch plunger position and brake pedal position.

Procedure:

1. With the switch still removed from the pedal box, push the plunger fully inwards towards the switch housing (light resistance will be felt until the plunger overcomes its ratchet mechanism).

2. Pull the plunger outwards to its mid point setting (approximately half way out from the switch housing, 5 audible clicks should be heard as it is being pulled) note, the plunger is on a stiff ratchet mechanism which may take some effort to extend.

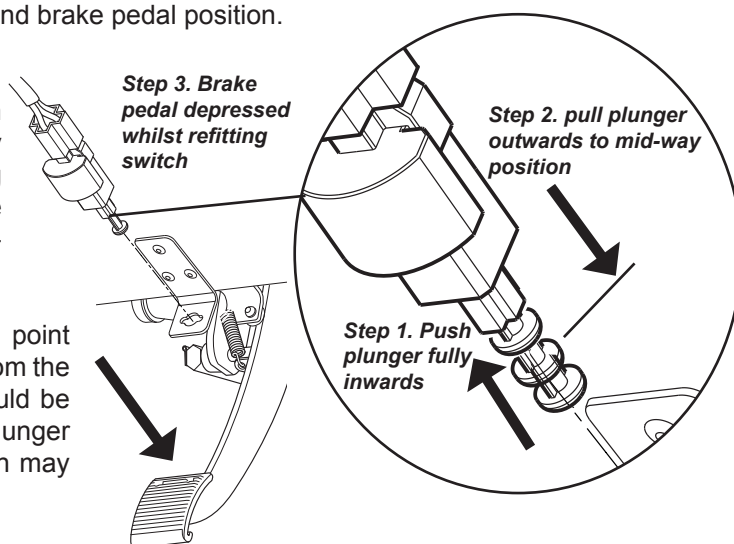

3. Using your hand to push down on the brake pedal, refit the brake switch back into its pedal box bracket.

Continued.....

LOTUS CARS LIMITED

4. Gently release the brake pedal back to its normal position against its bump-stop.

5. From the available items in Live Data, select 'Pressure Sensor' in addition to the options already selected.

6. Select the 'play' option and gently depress and release the brake pedal to simulate normal braking operations and examine the value readings displayed on ABS live data in relation to:

- 'Brake Switch' (1st stage)
- 'Brake Light Switch (03)' (2nd stage)
- 'Pressure Sensor' (ABS brake line pressure).

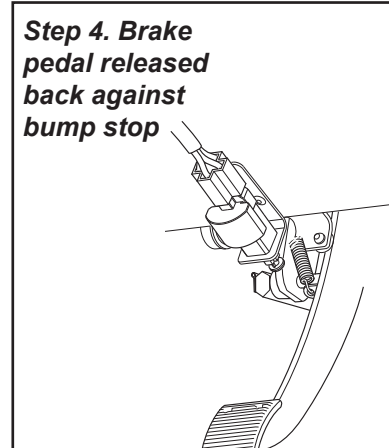

Normal Values Proportional To Brake Pedal Depression

No pedal effort - no pedal travel

- 'Brake Switch' (1st stage) No Actuation
- 'Brake Light Switch (03)' (2nd stage) No Actuation
- 'Pressure Sensor' (ABS brake line pressure) + or - 0.5 Bar

Selected Items	
Brake light switch (03)	No Actuation
Brake switch	No Actuation
Pressure sensor	-0.33 bar

Initial/light pedal effort - minor pedal travel

- 'Brake Switch' (1st stage) Actuated
- 'Brake Light Switch (03)' (2nd stage) No Actuation
- 'Pressure Sensor' (ABS brake line pressure) +/- 0.5 Bar

Selected Items	
Brake light switch (03)	No Actuation
Brake switch	Actuated
Pressure sensor	0.33 bar

Light/moderate pedal effort - increased pedal travel

- 'Brake Switch' (1st stage) Actuated
- 'Brake Light Switch (03)' (2nd stage) Actuated
- 'Pressure Sensor' (ABS brake line pressure) + 2 - 6 Bar

Selected Items	
Brake light switch (03)	Actuated
Brake switch	Actuated
Pressure sensor	2.28 bar

7. If the readings are not within range then remove the brake light switch again repeating step 2 of the adjustment procedure but adjusting the plunger inwards or outwards against its ratched mechanism as necessary until the correct readings are achieved.

8. Clear the fault code(s) and perform a vehicle road test to ensure the code(s) do not return

Note: Only if after performing this procedure the relevant tell tale light remains illuminated and the fault code(s) return should other causes of failure be investigated.

CHARGES:

At time of bulletin publication, prior authorisation is required if carrying out this procedure on Exige S (V6), please contact your nominated FSE (Field Service Engineer) or the Warranty Department for authority to submit a warranty claim.

If approved claims for 0.2 hr labour may be submitted quoting Operation Code 14.01.03 - 00, 'A' code 15, 'B' code 37. Please quote the fault code generated as well as the tell tale light illuminated in the remarks column text.

Ends.

LOTUS CARS LIMITED