



## Preliminary Information

### PIP4495F Cylinder Head Tick Noise And Or Damage - Possible Plugged Oil Feed Orifice

#### Models

Brand:	Model:	Model Years:	VIN:		Engine:	Transmissions:
			from	to		
Buick	Allure (Canada only)	2010	All	All	2.4L LAF, LUK	All
Buick	LaCrosse (including Hybrid, eAssist)	2011 - 2016	All	All	2.4L LAF, LEA, LUK	All
Buick	Regal (including Hybrid, eAssist)	2011 - 2017	All	All	2.0L LHU, 2.4L LAF, LEA, LUK	All
Buick	Verano	2012 - 2017	All	All	2.0L LHU, 2.4L LEA	All
Chevrolet	Captiva	2010 - 2017	All	All	2.4L LAF, LEA	All
Chevrolet	Cavalier	2002 - 2005	All	All	2.2L L61	All
Chevrolet	Cobalt (including SS)	2004 - 2010	All	All	2.0L LNF, LSJ, 2.2L LAP, LE8 2.4L LAT, LE5	All
Chevrolet	Equinox	2010 - 2017	All	All	2.4L LAF, LEA	All
Chevrolet	HHR (including SS)	2006 - 2011	All	All	2.0L LNF, LSJ, 2.2L LAP LE8, 2.4L LAT, LE5	All
Chevrolet	Impala (VIN 1 )	2014	All	All	2.4L LUK	All
Chevrolet	Malibu (including ECO, eAssist, Hybrid and Classic)	2004 - 2014	All	All	2.2L L61, 2.4L LAT, LE5, LE9, LUK	All
GMC	Terrain	2010 - 2017	All	All	2.4L LAF, LEA	All
Oldsmobile	Alero	2002 - 2004	All	All	2.2L L61	All
Pontiac	G5	2007 - 2010	All	All	2.0L LNF, LSJ, 2.2L LAP, LE8, 2.4L LAT, LE5	All
Pontiac	G6	2006 - 2010	All	All	2.4L LAT, LE5	All
Pontiac	Grand Am	2002 - 2005	All	All	2.2L L61	All
Pontiac	Pursuit (Canada Only)	2005 - 2006	All	All	2.2L L61, 2.4L LAT, LE5	All
Pontiac	Sunfire	2002 - 2005	All	All	2.2L L61	All
Pontiac	Solstice (including GXP)	2006 - 2010	All	All	2.0 LNF, 2.4L LE5	All

Brand:	Model:	Model Years:	VIN:		Engine:	Transmissions:
			from	to		
Saturn	Aura (including Hybrid)	2007 - 2009	All	All	2.4L LAT, LE5, LE9	All
Saturn	ION (including Redline)	2003 - 2007	All	All	2.0L LNF, LSJ, 2.2L L61, 2.4L LAT, LE5	All
Saturn	L Series	2001 - 2005	All	All	2.2L L61	All
Saturn	SKY (including Redline)	2007 - 2010	All	All	2.0L LNF, LSJ, 2.2L L61, 2.4L LAT, LE5, LE9	All
Saturn	VUE (including Hybrid)	2002 - 2010	All	All	2.2L L61, 2.4L LAT, LE5	All

### Supersession Statement

This PI was superseded to update the Labor Operation number. Please discard PIP4495E.

The following diagnosis might be helpful if the vehicle exhibits the symptom(s) described in this PI.

### Condition / Concern

**Some customers may complain of a loud tick/rattle noise under the hood at all operating conditions.**

**In some cases, the noise may have started shortly after an oil change or previous internal engine repairs.**

**During diagnosis, the technician will find that the noise is coming from the cylinder head area and believes that several/all of the valve lash adjusters (lifters) are making noise.**

**The cylinder head is equipped with oil feed orifice (2) that may become plugged with debris, such as excessive RTV/sealer or broken down oil filter material.**

**If this occurs, this noise may occur as a result of no/low oil pressure to the valve train.**

### Recommendations / Instructions

If a major valve train noise is encountered that sounds like several/all valve lash adjusters (lifters), it is suggested to compare the lower end oil pressure to the upper end oil pressure as outlined below:

1. Check the lower end oil pressure by attaching an oil pressure gauge to the oil pressure sender port or to one of the gallery plug ports in the engine block.
2. Check the upper end oil pressure by attaching another oil pressure gauge to one of the oil gallery plug ports on the back of the cylinder head (1).
3. Start the engine and note the oil pressure gauge readings from both locations while at the same engine RPM and engine temperature.
4. Turn the engine off.
5. Compare the oil pressure readings.
  - 5.1 If the lower end oil pressure is below SI specification, this PI does not apply so normal SI diagnosis should be followed to diagnose and repair the noise.
  - 5.2 If the upper end oil pressure is near 0 PSI/KPA but the lower end oil pressure is within SI specification, the oil feed orifice (2) is most likely plugged with debris. Please note that it is not uncommon for the upper end oil pressure of a normally functioning engine at idle to measure as much 35% less than the bottom end oil pressure. This is due to the large amount of oil pressure bleed off that normally occurs in the valve train, combined with the small size of the oil feed orifice (2).

If you suspect a plugged oil feed orifice after performing the test above, remove the cylinder head and visually inspect the oil feed orifice (2) for debris. If debris is present, it can normally be cleaned out to repair the noise. Please note that the orifice is not available separate from the cylinder head and cannot be inspected/cleaned without cylinder head removal.

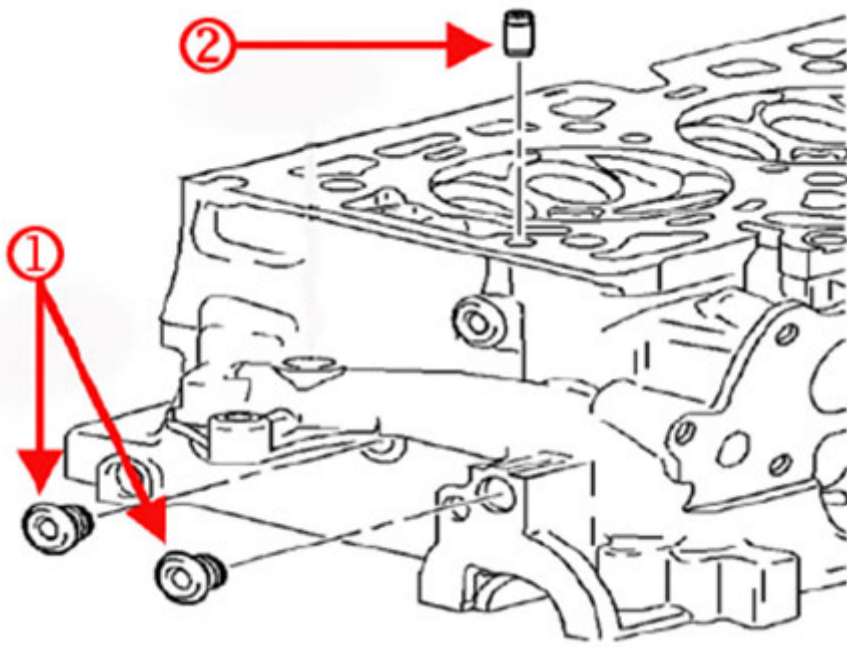

**Important:** To prevent future concerns, care must be taken not to use excessive amounts of engine sealant during internal engine repairs, use the proper oil filter that is listed in the parts catalog, and change the engine oil/filter according to the schedule in the owner's manual.

**Notice:** The oil gallery plug port threads (1) on the back of the cylinder head are M12x1.75 and it is unlikely that a related oil pressure gauge adapter will be found at a hardware or auto parts store. The 509376 Kent Moore Fitting that comes with the Engine Preluber Kit (EN-45299/J-45299) will screw into the head and may be adapted to some oil pressure gauges. Or, there are also several online retailers that can supply a fitting that will work as an adapter - the male end has to be M12x1.75 while the female end has to be 1/8"x27 NPTF so a standard oil pressure gauge hose can screw into it. It has also been found that some automotive gauge companies, such as Auto Meter, offer the necessary adapter/fitting (M12x1.75 / 1/8"x27 NPTF) for \$5-\$20. Some technicians have also reported success in making a temporary fitting out of an oil pressure sender body.

### Warranty Information

**For vehicles repaired under warranty, use:**

Labor Operation	Description	Labor Time
4061730	Cylinder Head Gasket Replacement	Use Published Labor Operation Time

Please follow this diagnostic or repair process thoroughly and complete each step. If the condition exhibited is resolved without completing every step, the remaining steps do not need to be performed.

### Additional SI Keywords

adjuster cam camshaft follower installation lash lifter replacement valve



GENERAL MOTORS