

WJ22 - Replacing Fuel Pump (Workshop Campaign)

Important: **CRITICAL WARNING** - This campaign includes steps where control unit(s) in the vehicle will be programmed with the PIWIS Tester. The vehicle voltage must be maintained between 13.5 volts and 14.5 volts during this programming. Failure to maintain this voltage could result in damaged control unit(s). Damage caused by inadequate voltage during programming is not a warrantable defect. The technician must verify the actual vehicle voltage in the PIWIS Tester before starting the campaign and also document the actual voltage on the repair order.

Model Year: **2018**

Vehicle Type: **911 Carrera (991)/911 Carrera S (991)/911 Carrera GTS (991)**

Subject: **Electric fuel pump**

Information: **There is a possibility that a fuel pressure control valve with a characteristic that does not meet the required specifications was installed in the fuel pump on the affected vehicles.**

If this is the case, the valve will open too early and the fuel pressure will fall below the specified minimum pressure. This can result in a reduced fuel supply and the Check Engine light may be activated.

Remedial Action: Replace fuel pump.

Affected Vehicles: Only the vehicles assigned to the campaign (see also PIWIS Vehicle information). This campaign affects 78 vehicles in North America.

Installation

Position:

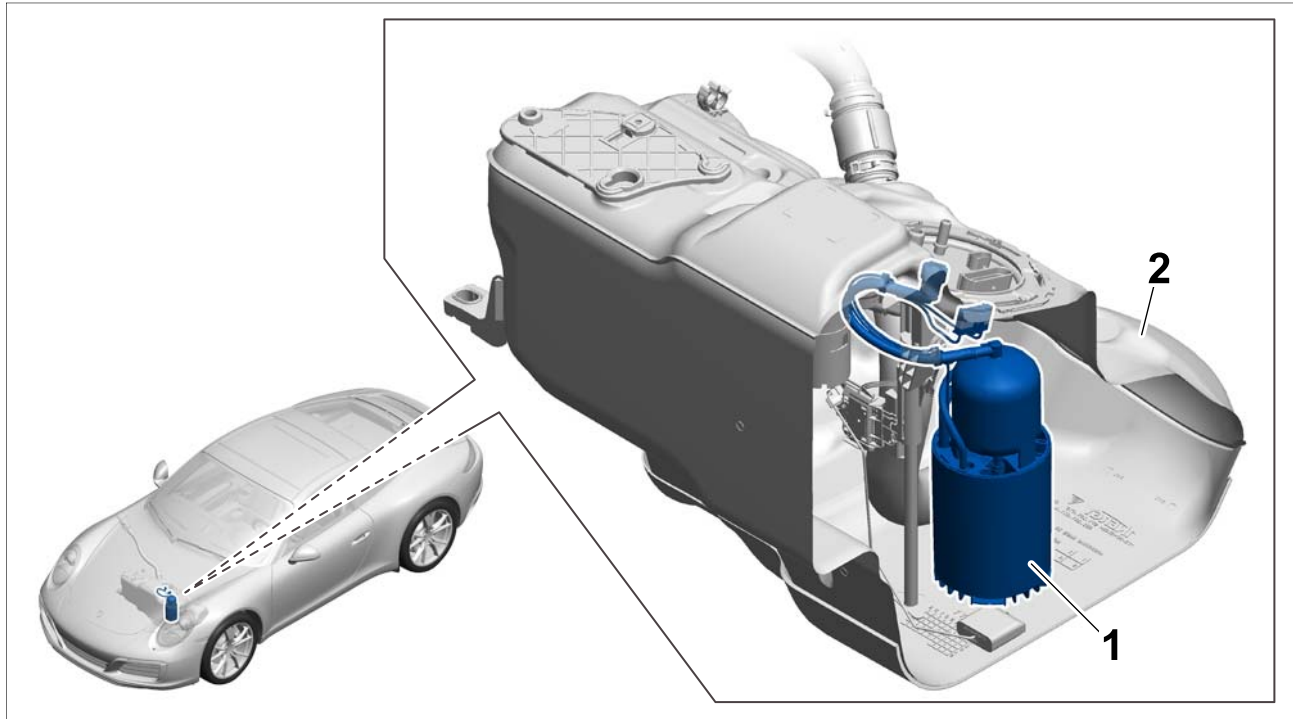

Installation position overview

- 1 – Fuel pump with connecting flange (**replace**)
 2 – Fuel tank

Parts required

Parts Info: **Parts for this campaign will NOT be automatically allocated to your dealership. Parts can be ordered as normal with no PTEC/PAV required.**

Part No.	Designation – Use	Qty.
00004330423	⇒ Fuel pump – Fuel low-pressure supply	1 ea.
99120173301	⇒ Sealing ring – Fuel tank flange	1 ea.

Required tools

- Tools:
- **9731/1 - Pin wrench** for bayonet flange ring on the fuel tank
 - Torque wrench, 2 - 10 Nm (1.5 - 7.5 ftlb.), e.g. **V.A.G 1783 - Torque wrench, 2-10 Nm (1.5-7.5 ftlb.)** or equivalent

- Torque wrench, 6 - 50 Nm (4.5 - 37 ftlb.), e.g. **V.A.G 1331A - Torque wrench, 6-50 Nm (4.5-37 ftlb.)**
- Connecting line **no. 18** from tool set **V.A.G 1318 - K-Jetronic pressure tester** (also known as VW1318)
- Suitable container for collecting fuel
- **9900 - PIWIS Tester 3**
- Battery charger with a current rating of **at least 90 A**, e.g. **VAS 5908**



Information

If the fuel tank fill level is **greater than the reserve** (remaining fuel range warning is **not** displayed in the instrument cluster), the fuel tank must be **drained completely** in order to **remove and install the fuel pump**.

On the affected vehicles, the fuel can be **drained completely** into a suitable collection container by selecting the **"Drain fuel tank"** function in the DME control unit using the **PIWIS Tester**.

If it is not possible to drain the fuel tank completely using the PIWIS Tester, the tank can be drained using a suitable fuel extraction unit or fuel transfer unit.

The following equipment has been tested and approved by Porsche and will also be required in this case:

- **WE1262 - Fuel transfer unit Tank Primus 100/100 S**
- **P378c connecting Lines** (Supersedes to VAS 5190A)
- **VAS 5190A - Fuel extractor**
- **9705/3 connecting lines** (or locally available equivalent tool)

Preparatory work



Highly flammable or explosive materials

- **Danger of fire or explosion**
- ⇒ **Avoid contact with hot parts or sources of ignition.**
- ⇒ **Use suction to remove ignitable vapors.**
- ⇒ **Attach warning sign in a clearly visible position.**



Caustic fluid

- **Danger of chemical burns**
- ⇒ **Avoid contact with caustic fluid.**
- ⇒ **Wear personal protective gear.**

- ⇒ **Ensure that there is good ventilation.**
- ⇒ **If you do come into contact, wash off immediately with plenty of warm water and contact a doctor if necessary.**

Work Procedure: 1 Switch on ignition and read off the fuel tank fill level on the fuel-level indicator in the instrument cluster. Then switch off the ignition.



Information

Depending on the fuel tank fill level, various steps are required for draining the fuel tank during this campaign.

- Fuel tank **completely full** (all segments of the fuel-level indicator activated): Before removing the **flange cover** on the fuel tank, **at least 20 liters** of fuel must be pumped out using the PIWIS Tester.
 - Fuel tank fill level **greater than the reserve**: Before removing the **fuel pump**, the fuel tank must be **drained completely** using the PIWIS Tester or a suitable fuel extraction unit or fuel transfer unit.
- 2 Remove plastic cover in the luggage compartment ⇒ *Workshop Manual '852219 Removing and installing technical equipment space cover'*.
 - 3 Remove the battery ⇒ *Workshop Manual '270619 Removing and installing battery'*.

NOTICE

Fuel can leak out when flange cover is removed when fuel tank is full

- **Danger of fire, explosion or contact with fuel**
- ⇒ **If the fuel tank is full, approx. 20 liters of fuel must first be pumped out in order to remove the flange cover.**
 - ⇒ **For other work on the fuel tank, e.g. for removing and installing the fuel pump, the tank must be drained to at least the reserve quantity.**
- 4 If the fuel tank fill level is **greater than the reserve** (remaining fuel range warning was **not** previously displayed in the instrument cluster), drain the fuel tank.



Information

On the affected vehicles, the fuel can be **drained completely** into a suitable collection container by selecting the "**Drain fuel tank**" function in the DME control unit using the **PIWIS Tester**.

If it is not possible to drain the fuel tank completely using the PIWIS Tester, the tank can be drained after removing the flange cover with fuel level sender as part of this campaign. If the **fuel tank is full**, however, **at least 20 liters** of fuel must be pumped out using the PIWIS Tester **before removing** the flange cover.

To drain the fuel tank **using the PIWIS Tester**, carry out the following steps.

- 4.1 Detach battery console with control unit for fuel pump and move it aside. **Do not disconnect** the electric plug connection on control unit for fuel pump initially.
For instructions, see ⇒ *Workshop Manual '508419 Removing and installing battery console'*.
- 4.2 Ensure a reliable power supply for the vehicle using a battery charger.
To do this, connect the positive terminal of the charger to the **jump-start terminal on the fuse carrier in the left footwell**.
Connect the negative terminal of the charger to the front ground point.
- 4.3 Carry out other tasks required for draining the fuel as described under ⇒ *Workshop Manual '200317 Draining and filling fuel'*.
- 4.4 Switch off the battery charger and disconnect it from the vehicle.

Replace fuel pump

Work Procedure: 1 Completely remove battery console with control unit for fuel pump ⇒ *Workshop Manual '508419 Removing and installing battery console'*.

NOTICE

Fuel can leak out when flange cover is removed when fuel tank is full

- **Danger of fire, explosion or contact with fuel**
- ⇒ **If the fuel tank is full, approx. 20 liters of fuel must first be pumped out in order to remove the flange cover.**
- ⇒ **For other work on the fuel tank, e.g. for removing and installing the fuel pump, the tank must be drained to at least the reserve quantity.**

- 2 Remove fuel level sender ⇒ *Workshop Manual '201519 Removing and installing fuel level sender'*.
- 3 If the fuel tank was **not drained completely** beforehand using the PIWIS Tester, drain the fuel tank using a fuel extraction unit or fuel transfer unit.



Information

The following fuel extraction or fuel transfer units have been tested and approved by Porsche and will also be required in this case:

- **WE1262 - Fuel transfer unit Tank Primus 100/100 S**
- **VAS 5190A - Fuel extractor**

For instructions, see ⇒ *Workshop Manual '200317 Draining and filling fuel'*.

- 4 Remove fuel pump and install a new fuel pump ⇒ *Workshop Manual '206619 Removing and installing fuel pump'*.

Part No.	Designation – Use	Number or quantity
00004330423	Fuel pump – Fuel low-pressure supply	1 ea.

- 5 Install fuel level sender.
Always use a **new sealing ring** for the flange on the fuel tank.
For instructions, see ⇒ *Workshop Manual '201519 Removing and installing fuel level sender'*.

Part No.	Designation – Use	Number or quantity
99120173301	Sealing ring – Fuel tank flange	1 ea.

- 6 Fill the fuel tank ⇒ *Workshop Manual '200317 Draining and filling fuel'*.

Concluding work

Work Procedure: 1 Install battery console ⇒ *Workshop Manual '508419 Removing and installing battery console'*.

- 2 Install battery ⇒ *Workshop Manual '270619 Removing and installing battery'*.
Then carry out the work required after connecting the battery ⇒ *Workshop Manual '2X00IN Work instructions after disconnecting the battery'*.

- 3 Check the fuel system for leaks.
To do this, switch on the ignition and wait until you hear the fuel pump building up pressure. Then perform a **visual inspection** of the fuel system in the **connecting flange area on the fuel tank**.

- 4 Install plastic cover in the luggage compartment ⇒ *Workshop Manual '852219 Removing and installing technical equipment space cover'*.

- 5 Enter the campaign in the Warranty and Maintenance booklet.

References: ⇒ *Workshop Manual '2X00IN Work instructions after disconnecting the battery'*
⇒ *Workshop Manual '200317 Draining and filling fuel'*
⇒ *Workshop Manual '201519 Removing and installing fuel level sender'*
⇒ *Workshop Manual '206619 Removing and installing fuel pump'*
⇒ *Workshop Manual '270619 Removing and installing battery'*
⇒ *Workshop Manual '508419 Removing and installing battery console'*
⇒ *Workshop Manual '852219 Removing and installing technical equipment space cover'*

Warranty processing



Information

The specified working time was determined specifically for carrying out this campaign and may differ from the working times published in the Labour Operation List in PIWIS.

Scope 1:

Replace fuel pump

- 911 Carrera (991)/911 Carrera S (991)/911 Carrera GTS (991)

Working time:

Replacing fuel pump Labor time: **173 TU**

Includes:

- Connecting and disconnecting PIWIS Tester
- Connecting and disconnecting battery charger
- Draining and filling fuel
- Removing and installing cover in luggage compartment
- Removing and installing battery
- Removing and installing battery console
- Removing and installing fuel level sender

Parts required:

00004330423	Fuel pump	1 ea.
99120173301	Sealing ring	1 ea.

⇒ **Damage Code WJ22 066 000 2**

Important Notice: Technical Bulletins issued by Porsche Cars North America, Inc. are intended only for use by professional automotive technicians who have attended Porsche service training courses. They are written to inform those technicians of conditions that may occur on some Porsche vehicles, or to provide information that could assist in the proper servicing of a vehicle. Porsche special tools may be necessary in order to perform certain operations identified in these bulletins. Use of tools and procedures other than those Porsche recommends in these bulletins may be detrimental to the safe operation of your vehicle, and may endanger the people working on it. Properly trained Porsche technicians have the equipment, tools, safety instructions, and know-how to do the job properly and safely. Part numbers listed in these bulletins are for reference only. The work procedures updated electronically in the Porsche PIWIS diagnostic and testing device take precedence and, in the event of a discrepancy, the work procedures in the PIWIS Tester are the ones that must be followed.