

Infiniti USA
Electronic Field Communication

ACTION

Date: June 13, 2018

To: FOMs, DOMS, and RSOMs

Subject: 2019 QX50 PGF Film Removal – Supplemental Information

ACTION: FOMs & DOMs are asked to ensure that retailers are aware of this supplemental information and immediately remove any protective film from the panoramic moonroof finishers on vehicles in inventory or newly arriving inventory for vehicles manufactured before June 8, 2018.

| Affected Models/Years: | Affected Population: | Retailer Inventory: | SERVICE COMM Activation date: | Stop Sale In Effect |
|------------------------------------|----------------------|---------------------|-------------------------------|---------------------|
| 2019 QX50 Luxe & Essential Models* | NA | ~5,863 | Not Available in Service Comm | NO |

What Retailers Should Do:

This information applies to 2019 QX50 equipped with a panoramic moonroof only. In reference to bulletin ITBO1-024e, there is a clear protective tape on the right and left moonroof trim finishers which also should be removed during the PGF removal process. If this action has not been completed on vehicles in retailer inventory, please perform this action immediately to ensure easy removal and avoid trim damage.

Key points:

Use a tool that will not scratch the surface of the finishers or surrounding areas of the vehicle to peel the edge of the film back, then remove the film from the entire surface of the right and left trim.

Refer to the illustrations below:





Reference Only:

| No | Part Code | Qty | Part Number | Description | Per Veh | Sec. |
|----|-----------|-----|--------------|-----------------------|---------|------|
| 1 | 73836 | 4 | 91760-5NA0A- | FINISHER ASSY-ROOF,RH | 01 | 736 |
| 2 | 73837 | 4 | 91761-5NA0A- | FINISHER ASSY-ROOF,LH | 01 | 736 |

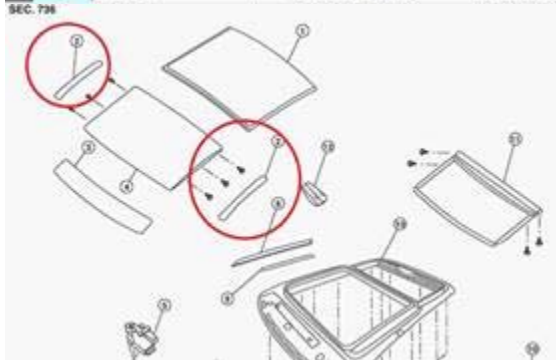

Attachments (1):

1. ITB01-024e

Retailer Communication: YES

This information will be distributed to regional and retailer personnel on June 13,2018.

Retailer Personnel in the following positions will receive a direct email notification of this notice using the email address entered into NNAnet.

| Position Name |
|-------------------|
| Dealer Principal |
| Executive Manager |

| |
|--|
| General Manager |
| General Sales Manager |
| Part & Service Director |
| Parts Director |
| Parts Manager |
| Service Advisor/Consultant |
| Service Advisor/Consultant - Express Service |
| Service Director |
| Service Manager |

If any retailers are not receiving this information via email from the campaignannouncements@nissan-usa.com mailbox, please check spam folders and enable their inbox to process these emails as a safe sender. All retailer email addresses for these positions are taken from the retailer portal (NNAnet) and updated regularly. Retailers should verify the retailer portal administrator has the current contact information entered for these key positions to ensure information is received.

Originator: Andrea Bennett
Phone: 615-725-5481
Email: Andrea.Bennett@nissan-usa.com
Division: Aftersales
Department: Retailer Support