

ATTENTION: This Technical Service Bulletin was issued by Gulf States Toyota, Inc.

For Toyota Dealers located in the Gulf States Toyota Region: Please refer to GST Dealer Daily to obtain instructions on how to order parts and submit a warranty claim (If applicable).

For Toyota Dealers *NOT* located in Texas, Oklahoma, Mississippi, Arkansas or Louisiana: For Repair Authorization, Parts Ordering, and Warranty Claims please contact GST Accessory Technical Support at 1-800-444-1074.

Thank you for your continued support.



Running Board Sagging

Service Category: Accessory
Section: Body

Market: USA

Applicability

YEAR	MODEL	INSTALLED ACCESSORY INFORMATION		
		DESCRIPTION	ACCESSORY LIO CODE	PART NUMBER
2015-2017	Highlander	Brushed Stainless Steel Running Boards	R1	00012H-1573-01

NOTE

This TSB only applies to vehicles invoiced at Gulf States Toyota between 9/1/2015 – 11/6/2017.

Introduction

Some 2015-2017 MY Highlander vehicles equipped with Brushed Stainless Steel Running Boards accessory may exhibit a condition in which the rear portion of the running board sags if subjected to an unusual amount of pressure. The condition may be present on both the driver and passenger side of the vehicle. This repair procedure is intended to provide a resolution to this potential issue.



Running Board Sagging

Warranty Information

GST Installed Product				
Model	Highlander Model Years (2015-2017) Invoice Date (9/1/15-11/6/17) LIO	Highlander Model Years (2015-2017) DIO	Highlander Model Years (2015-2017) DIO	Highlander Model Years (2015-2017) Invoice Date (9/1/15-11/6/17) LIO
Operation Code	B18601	B18602	B18603	B18604
Operation Code Description	RH and LH brackets to be added	RH and LH brackets to be added	Repair beyond bracket addition. Invoice required.	Repair beyond bracket addition. Invoice required.
OFF	00012-H1573-01	00012-H1573-01	00012-H1573-01	00012-H1573-01
TSB No.	TS04	TS04	TS04	TS04
Trouble Code	99	99	99	99
Labor Time	1.0	1.0	1.0	1.0
Replacement Part	00012-H1873-11	00012-H1573-11	00012-H1573-11	00012-H1573-11
Replacement Part Quantity	1	1	1	1

NOTE

- Please reference the Warranty Instructions on how to file a claim for this TSB in Dealer Daily under the Warranty Tab.
- Search for TS04 – Highlander Bracket

APPLICABLE WARRANTY

- This repair is covered under the basic vehicle warranty. This warranty is in effect for 36 months or 36,000 miles, whichever occurs first, from the vehicle's in service-date.
- Warranty application is limited to occurrence of the specified condition described in this bulletin.



Running Board Sagging

Parts Information

Part Number	Part Description	Quantity
00012-H187311	Supplemental Bracket with Hardware	1

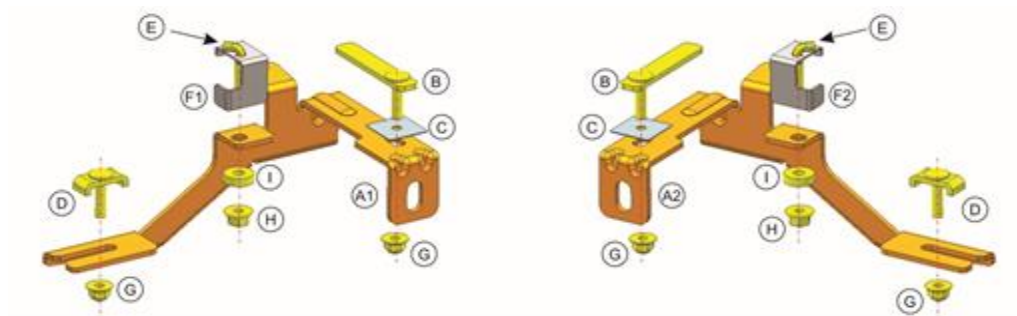

Reference	Qty	Description
A1	1	Passenger Side Supplemental Bracket
A2	1	Driver Side Supplemental Bracket
B	2	T-Bolt Plate
C	2	Square Spacer
D	2	U-Bolt Plate M10
E	2	L-Bolt M10
F1	1	Passenger Side Jack Shield Bracket
F2	1	Driver Side Jack Shield Bracket
G	4	Hex Flange Lock Nut M10 16mm
H	2	Hex Flange Lock Nut M10 17mm (silver)
I	2	Washer D10



Running Board Sagging

Repair Procedure

1. If vehicle exhibits condition described in this TSB, please contact your assigned FTS for further evaluation.
*** If you are a dealer outside of the Gulf States Toyota Region, please call 1-800-444-1074 for assistance.
2. Once FTS has provided next steps, proceed to step 3.
3. Does the vehicle exhibit condition?
 - a. **YES** – Proceed to Step 4
 - b. **NO** – This TSB does not apply
4. Raise the vehicle on lift and locate the rear attachment points of the running board (**Fig.1**)
5. Proceed to install the Supplemental Brackets. Steps 6-17 show how to install the supplemental bracket on RH of vehicle.
6. Remove and discard the rubber plugs indicated on **Fig. 2** which are located on the underside of vehicle.

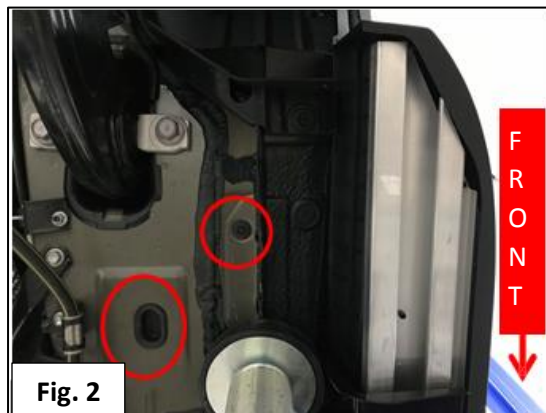
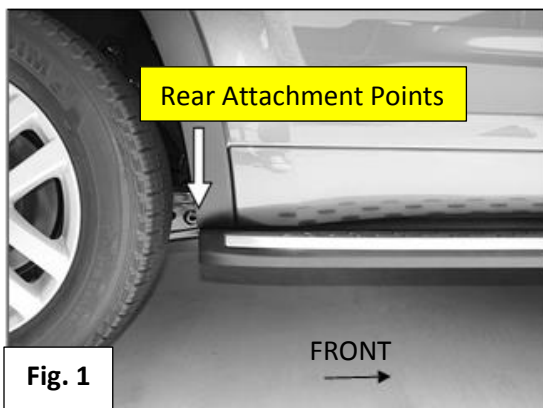

7. Place a U-bolt plate M10 at the end of the aluminum frame of the running board as shown in **Fig. 3**. Rotate the bolt 90 degrees counter-clockwise for attaching to the bracket.



Running Board Sagging

Repair Procedure (cont'd)

- Place a T-Bolt Plate into the hole exposed in the underside of the vehicle as shown in **Fig. 4**. Rotate the T-Bolt Plate to ensure the plate is orientated so the long end is pointing away from the door of the vehicle as indicated by the outline in the image.

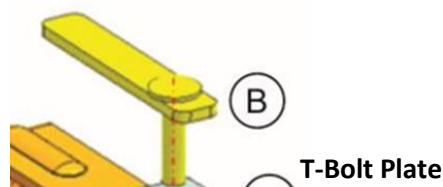
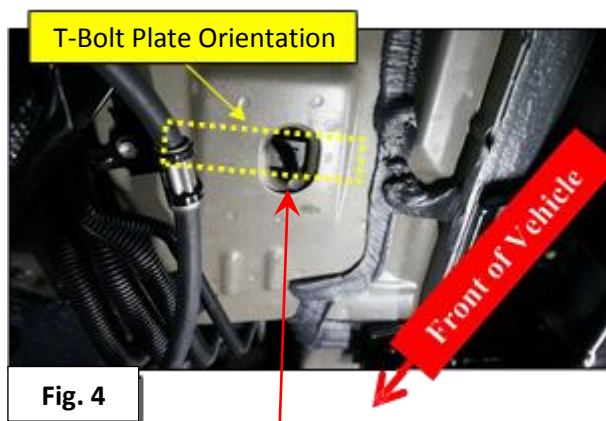
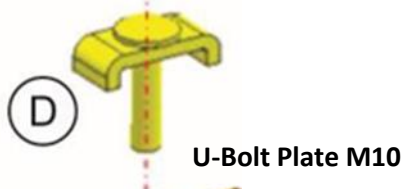
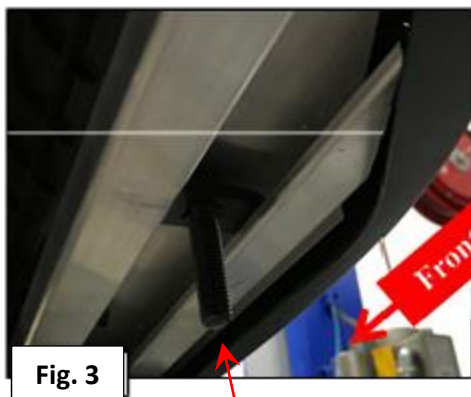

- Slide square spacer over the bolt of the T-Bolt Plate and press firmly against the vehicle. (Reference **Fig. 5**)

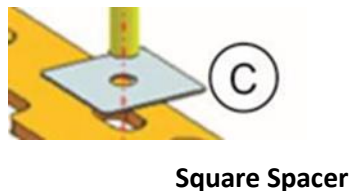
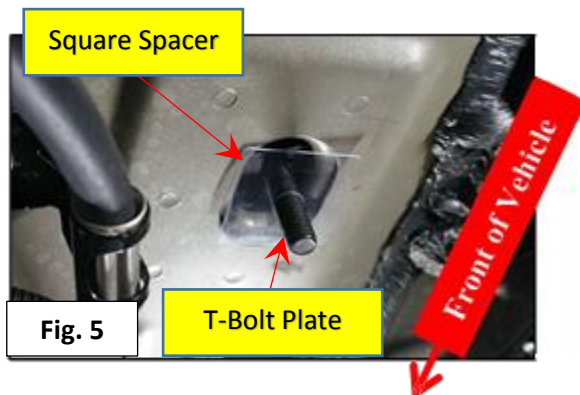



Running Board Sagging

Repair Procedure (cont'd)

10. Insert the short end of the silver L-Bolt M10 into the hole of the Jack Shield Bracket as shown in **Fig. 6**. Slide the L-Bolt through the hole so that the threaded portion of the bolt is perpendicular to the surface bracket.

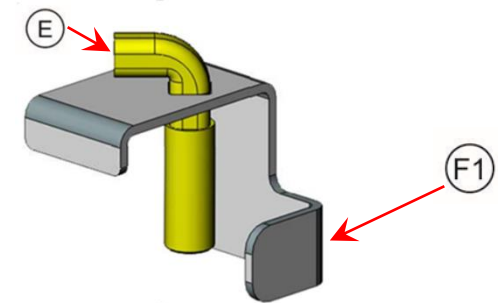

**RH side Jack Shield
Bracket with L-Bolt**



Running Board Sagging

Repair Procedure (cont'd)

11. Be sure that the Jack Shield Bracket is oriented such that the small tab is facing outward towards the door side of the vehicle and the larger flat side is facing the front of the vehicle as shown. (Reference **Fig. 7**)

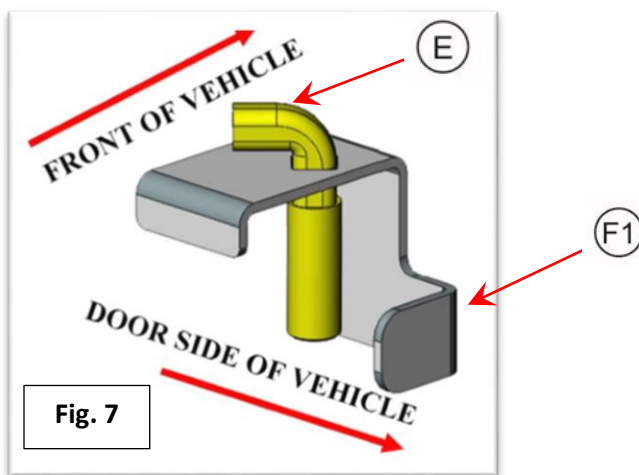

RH side Jack Shield
Bracket with L-Bolt

12. Insert the angled part of the L-Bolt into the hole as shown. The surface of the Jack Shield Bracket should rest against the surface of the vehicle. (Reference **Fig. 8**)

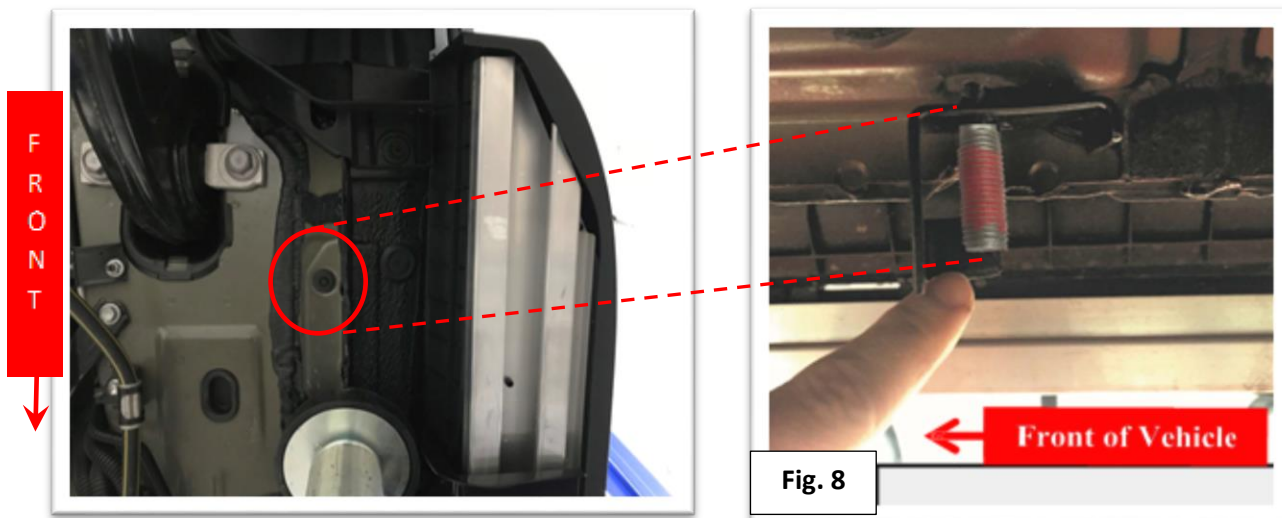



Running Board Sagging

Repair Procedure (cont'd)

13. Position the supplemental bracket over the bolts. (Reference **Fig. 11**)
14. Apply a Washer D10 to the center bolt **(I)** and secure using a silver Hex M10 Flange Lock Nut **(H)** (17mm) and finger tighten.
15. Apply a Hex M10 Flange Lock Nut **(G)** (16mm) to the other two bolts. (Reference **Fig. 9**)

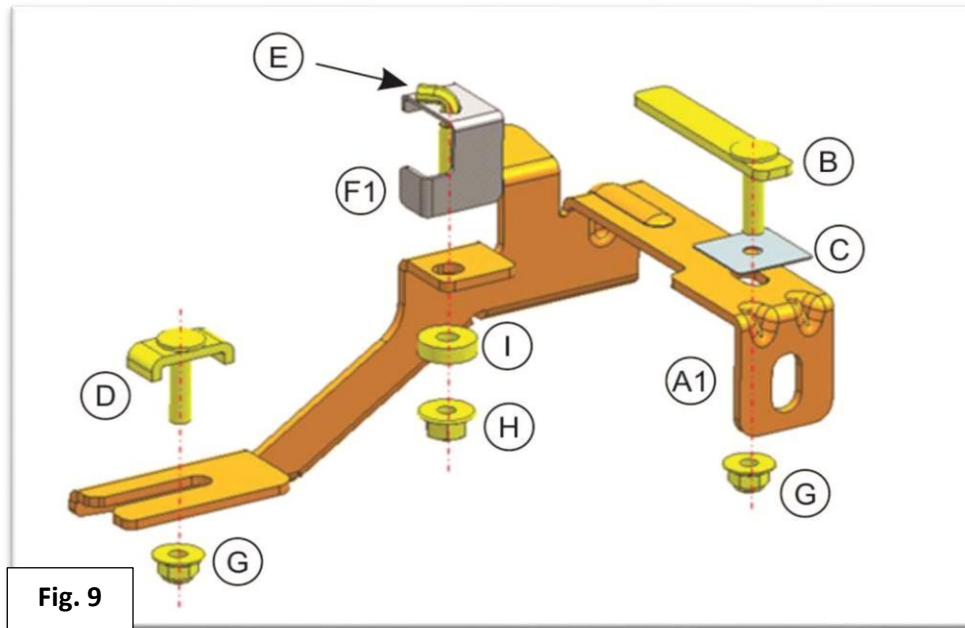

16. Check that the supplemental bracket is positioned as far forward towards the front of the vehicle ensuring a minimum clearance of 14mm between the supplemental bracket and the trailing arm. (Reference Fig. 10)

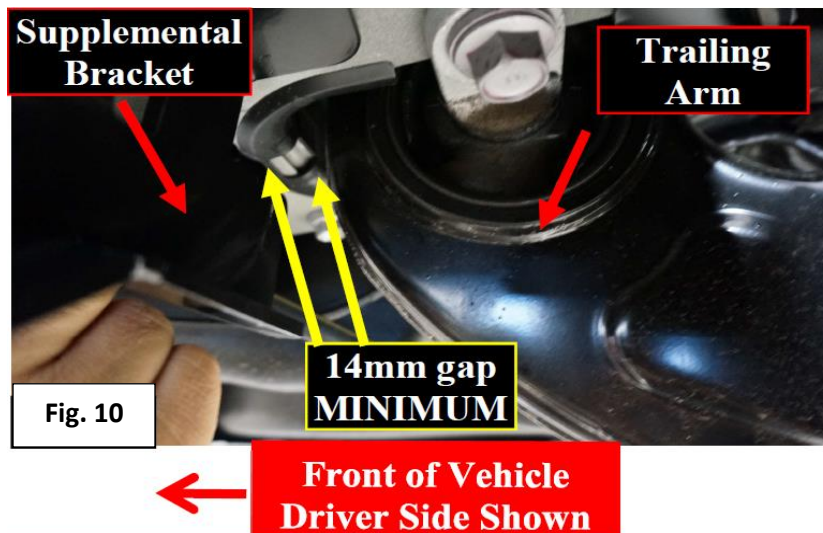



Running Board Sagging

17. Please follow the torque sequence shown in Fig.

1 - **28 ft.* lbs.**

2 - **28 ft.* lbs.**

3 - **15 ft.* lbs.**

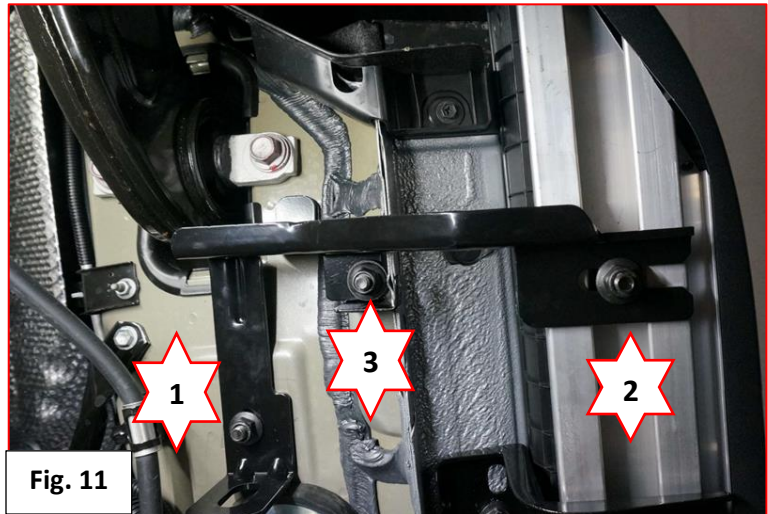

18. Repeat steps 6-17 to install supplemental bracket on LH side of vehicle.