



Subject: CREAKING NOISE FROM FRONT SHOCK ABSORBER WHEN GOING OVER BUMPS	Bulletin No.: 02-014/18
	Last Issued: 09/04/2018

APPLICABLE MODEL(S)/VINS

- 2014-2017 Mazda3
- 2018 Mazda3 (Japan built) vehicles with VINs lower than JM1BN*****190286 (produced before Apr. 3, 2018)
- 2018 Mazda3 (Mexico built)
- 2016-2019 CX-3 with VINs lower than JM1DK*****402484 (produced before Apr. 3, 2018)

DESCRIPTION

Some vehicles may experience a creaking noise from the front shock absorber when going over bumps. Upon inspection, the coil spring is found to be broken at the lower part without any trace of an accident. It may be found during maintenance or service opportunity without customer complaints. Mud and sand caught between the coil spring and the lower spring seat causes paint damage on the coil spring, resulting in rust holes and uneven force application. To correct this issue, the shape of the lower spring seat has been modified.

Customers having this concern should have their vehicle repaired using the following repair procedure.

REPAIR PROCEDURE

1. Verify customer concern.
2. Replace the broken coil spring (2) with a new one and the affected side spring seat (3) with a modified one according to the instruction on MGSS (FRONT SHOCK ABSORBER AND COIL SPRING DISASSEMBLY/ASSEMBLY).

- Mazda3 (FRONT SHOCK ABSORBER AND COIL SPRING DISASSEMBLY/ASSEMBLY)
- CX-3 (FRONT SHOCK ABSORBER AND COIL SPRING DISASSEMBLY/ASSEMBLY)

CONSUMER NOTICE: The information and instructions in this bulletin are intended for use by skilled technicians. Mazda technicians utilize the proper tools/equipment and take training to correctly and safely maintain Mazda vehicles. These instructions should not be performed by "do-it-yourselfers." Customers should not assume this bulletin applies to their vehicle or that their vehicle will develop the described concern. To determine if the information applies, customers should contact their nearest authorized Mazda dealership. Mazda North American Operations reserves the right to alter the specifications and contents of this bulletin without obligation or advance notice. All rights reserved. No part of this bulletin may be reproduced in any form or by any means, electronic or mechanical---including photocopying and recording and the use of any kind of information storage and retrieval system ---without permission in writing.

Mounting Rubber Removal Note

Put a position mark (4) on the mounting rubber (1) and piston rod (5) before removing the mounting rubber from the shock absorber assembly so the mounting rubber can be installed back in the original position. If this has been done, it is not necessary to adjust the front wheel alignment because the front shock absorber and the mounting rubber are not replaced.

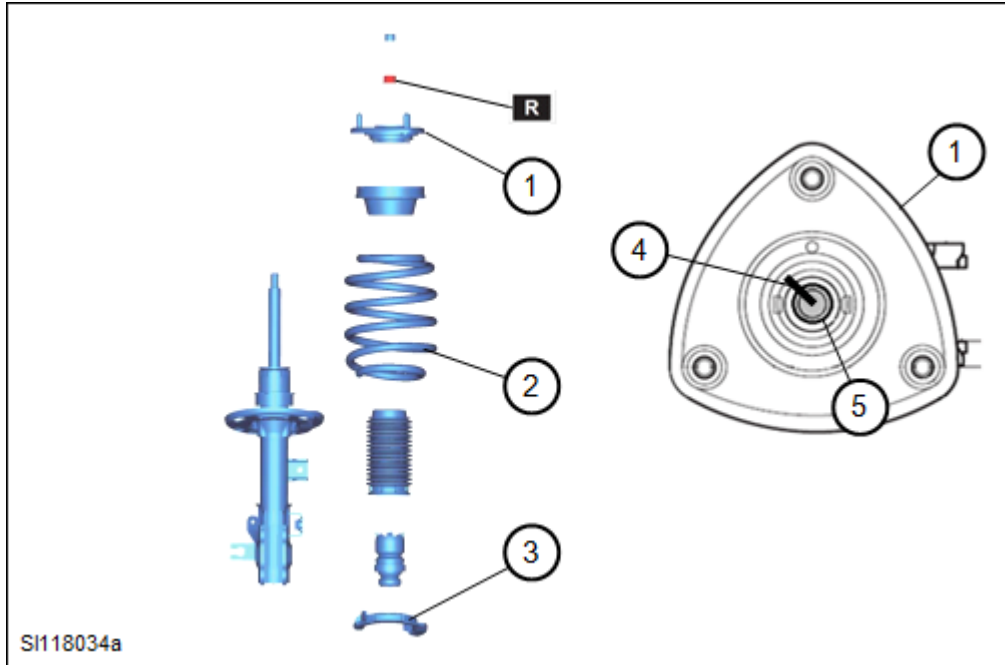

3. Verify repair.

PARTS INFORMATION

Confirm the part number in the EPC for the subject VIN and place an order for the corresponding (modified) service part.

Parts Number	Description	Qty.	Notes
***-34-011*	Spring, Coil-Front	1 or 2	---
D10E-34-0A3C	Rubber, Spring Seat - Lower	1 or 2	Japan built vehicles
BJS7-34-0A3A	Rubber, Spring Seat - Lower	1 or 2	Mexico built vehicles
9YB0-41-237	Nut	1 or 2	Replace part

CONSUMER NOTICE: The information and instructions in this bulletin are intended for use by skilled technicians. Mazda technicians utilize the proper tools/equipment and take training to correctly and safely maintain Mazda vehicles. These instructions should not be performed by "do-it-yourselfers." Customers should not assume this bulletin applies to their vehicle or that their vehicle will develop the described concern. To determine if the information applies, customers should contact their nearest authorized Mazda dealership. Mazda North American Operations reserves the right to alter the specifications and contents of this bulletin without obligation or advance notice. All rights reserved. No part of this bulletin may be reproduced in any form or by any means, electronic or mechanical--including photocopying and recording and the use of any kind of information storage and retrieval system ---without permission in writing.

WARRANTY INFORMATION

NOTE:

- This warranty information applies only to verified customer complaints on vehicles eligible for warranty repair.
- This repair will be covered under Mazda's New Vehicle Limited Warranty.
- Additional diagnostic time cannot be claimed for this repair.

Warranty Type	A
Symptom Code	82
Damage Code	97
Part Number Main Cause	D10E-34-0A3C or BJS7-34-0A3A
Quantity	1 or 2
Operation Number / Labor Hours:	XXP6WARX / 0.5 Hrs. (One side) XXP6WBRX / 0.7 Hrs. (Both sides)

CONSUMER NOTICE: The information and instructions in this bulletin are intended for use by skilled technicians. Mazda technicians utilize the proper tools/equipment and take training to correctly and safely maintain Mazda vehicles. These instructions should not be performed by "do-it-yourselfers." Customers should not assume this bulletin applies to their vehicle or that their vehicle will develop the described concern. To determine if the information applies, customers should contact their nearest authorized Mazda dealership. Mazda North American Operations reserves the right to alter the specifications and contents of this bulletin without obligation or advance notice. All rights reserved. No part of this bulletin may be reproduced in any form or by any means, electronic or mechanical---including photocopying and recording and the use of any kind of information storage and retrieval system ---without permission in writing.