



Door Opens to First Stage While Driving



New information provided by this revision is preceded by this symbol .

This Service Information bulletin replaces SI B51 16 14 dated **March 2015**

What's New:

- Models: added F85 (X5 M) and F86 (X6 M)
- Cause: added Soft Close Automatic drive (SCA) issues with locking levers
- Correction: added lock production date check/replacement
- Procedure: reworded and added lock inspection and replacement steps
- Warranty Information section updated– (elimination of work time to modify rear SCA drive)

MODEL

F15 (X5)	F16 (X6)	 F85 (X5 M)	 F86 (X6 M)
	With option 0323 Soft Close	Produced 7/1/13 through 11/20/15	

SITUATION

 The door opens to the first stage and the “Door Open” indicator (pictogram) will indicate the door affected. This can affect any door.

CAUSE

Automatic soft-close drive (Bowden cable lock).

 Soft-Close Automatic drive (SCA) locking levers are slow to respond to lock request.

CORRECTION

Replace **all** four Bowden cable covers and soft-close drives (SCA).

 Replace door lock(s), as needed, based on production code (see Step 5).

PROCEDURE

1. Ask the customer the following questions to classify the situation:

- Which door opened or showed open?
- Did the door open to the first stage?
- Did the “Door Open” indicator (pictogram) display the open door?

- Did the interior lights turn on?

2. Evaluate the display activity.

Did the customer report “Door Open” indicator (pictogram) AND the interior lights coming on?

YES- go to next step.

NO – continue diagnosis with ISTA.

3. Evaluate the door activity.

Did the door actually open to the first stage?

YES- Go to Step 4.

NO – continue diagnosis with ISTA checking the wiring harnesses for short circuits.

4. Replace the Bowden cable cover and the Bowden cable lock (Soft Close Automatic) drive on all four doors as described in the repair instructions (5121097 front / 5122097 rear) with the part numbers listed below. Refer to the B511614 attachment for the repair procedure.

5. Examine the production date on each door lock.



Note: The production date can be identified in the lock jaw (without removal). The date stamp has the

following format:

AABBCC where:

AA= Year of manufacture

BB= Calendar week

CC= Day of the week

Example: 151104 corresponds to 12 March 2015

Were the production dates later than 12 March 2015?

YES- repair is complete.

NO – each pre-dated lock must also be replaced.

PARTS INFORMATION

Part Number	Description	Quantity
51 21 7 325 297	Left side Bowden cable cover (front and rear)	2
51 21 7 325 298	Right side Bowden cable cover (front and rear)	2
51 21 7 281 945	Front left side front door lock	One as needed
51 21 7 281 948	Front right side front door lock	One as needed

51 22 7 281 955	Left side rear door lock	One as needed
51 22 7 281 956	Right side rear door lock	One as needed
51 20 7 419 839	F15/F16 Front left side soft-close drive	1
51 20 7 419 840	F15/F16 Front right side soft-close drive	1
51 20 7 419 841	F15 Left side rear soft-close drive	1
51 20 7 419 842	F15 Right side rear soft-close drive	1
51 20 7 419 843	F16 Left side rear soft-close drive	1
51 20 7 419 844	F16 Right side rear soft-close drive	1

Note: Do not mix any old part numbers with new part numbers.

WARRANTY INFORMATION

Covered under the terms of the BMW New Vehicle Limited Warranty for Passenger Cars and Light Trucks.

Defect Code:	6711101200	
Labor Operation:	Labor Allowance:	Description:
51 21 110	Refer to KSD2	Removing and installing or replacing lock of both front doors (Main work)
Or:		
51 21 650	Refer to KSD2	Removing and installing or replacing lock of both front doors (Plus work)
And:		
51 22 610	Refer to KSD2	Removing and installing or replacing lock of both rear doors as plus work

If you are using a Main labor code for another repair, use the Plus code labor operation 51 21 610 instead of 51 21 110.

Refer to KSD2 for the corresponding flat rate unit (FRU) allowance.

Monday, September 11, 2017

ATTACHMENTS

View PDF attachment [B511614 Attachment](#).

[Copyright ©2017 BMW of North America, Inc.]

Scenario 2 – For reference, the Repair Instruction for the rear door lock and soft-close drive removal procedure is shown in the next steps. Repair Instruction 5121090 should be referenced for the front door lock and soft-close drive removal.

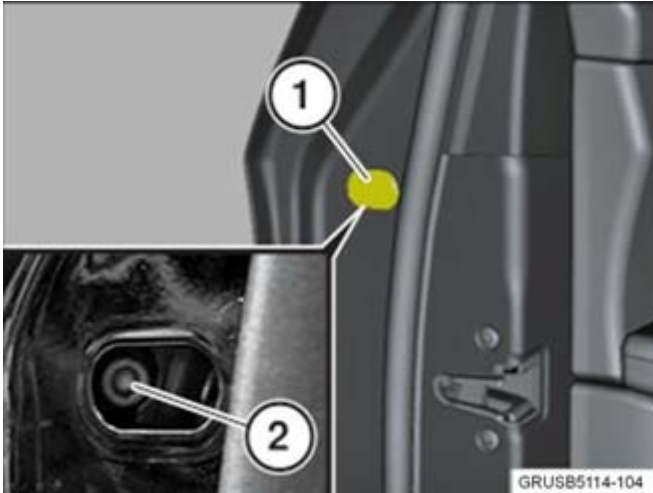

1. Pry out the trim cover (1) and remove the screw (2).

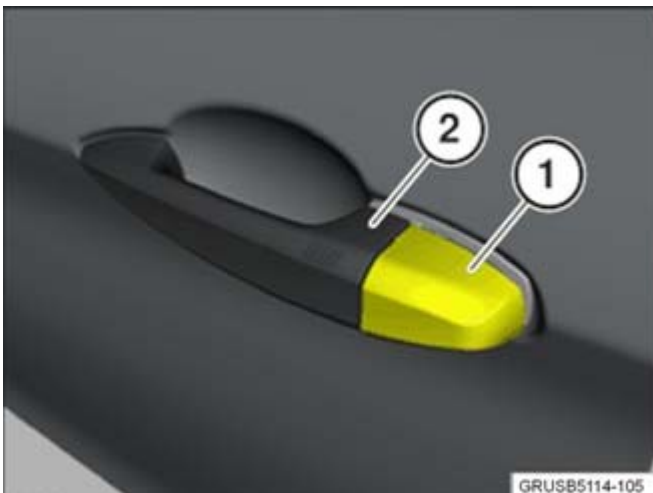

2. Pull the cover off (1) the door handle (2) by opening slightly.

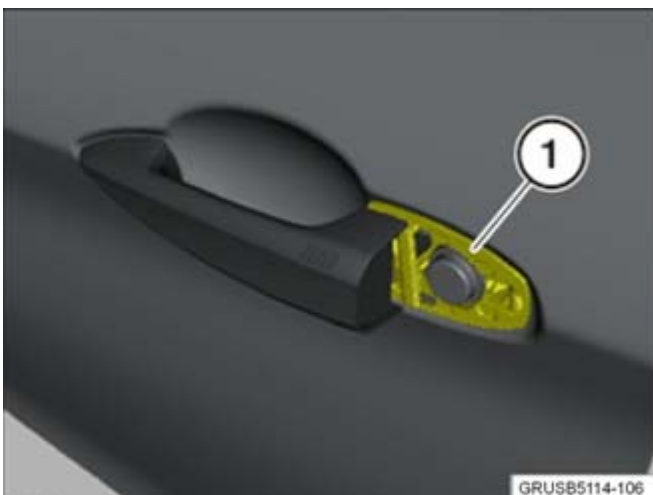

3. Installation note:
Ensure the gasket (1) is seated correctly.

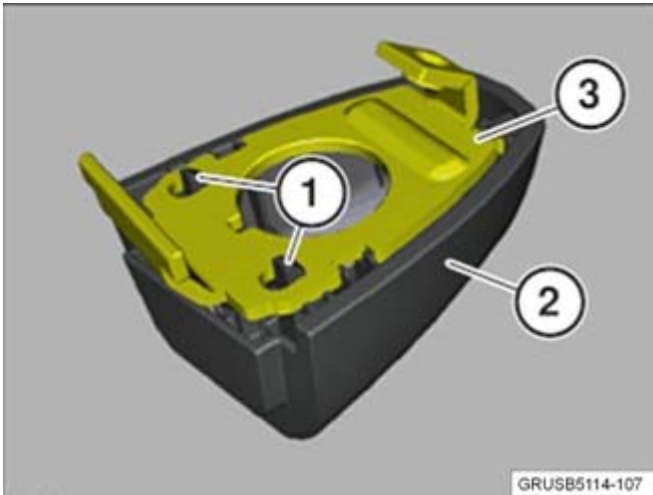

4. The latching mechanisms (1) of the cover (2) must not be damaged.

Replacement:

Remove the cover (2) from the retaining plate (3).

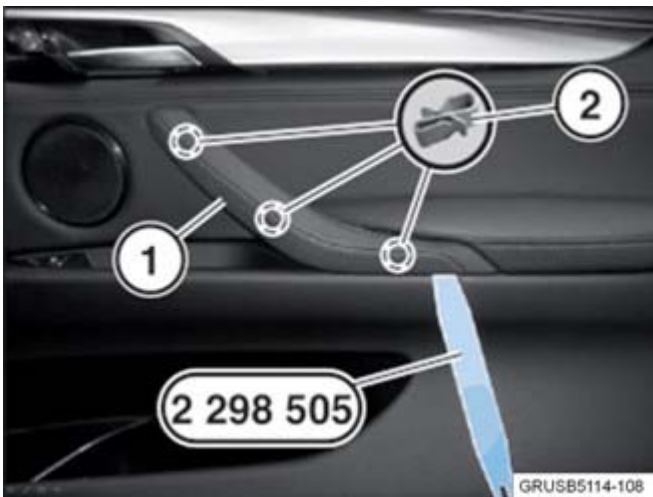

5. Pry the cover (1) from the clips (2) using special tool 2 298 505.

Installation note:

Replace any faulty clips (2).

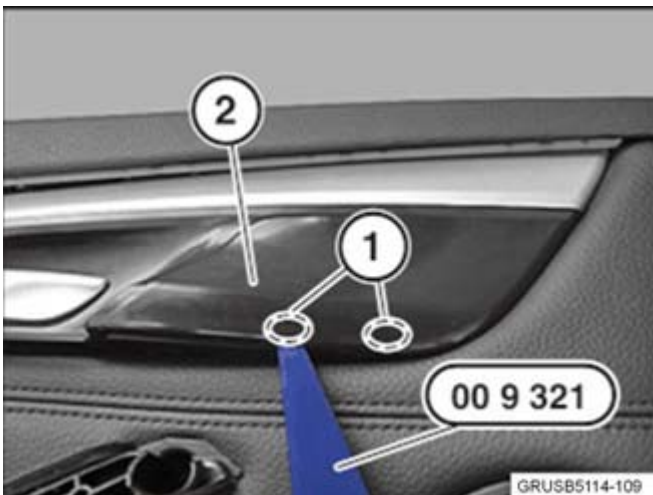

6. Pry the catches in area (1) using special tool 00 9 321. Unclip the trim (2).

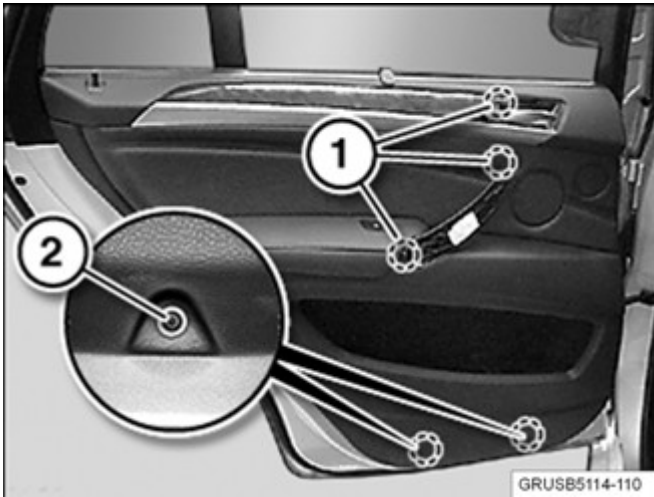

7. Remove all screws from (1) and (2).

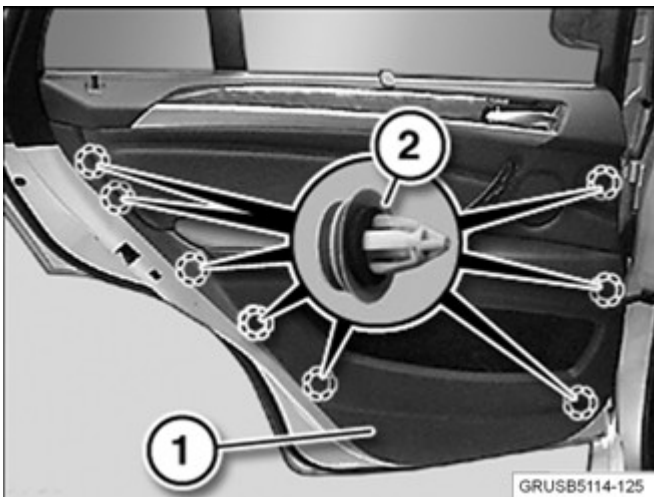

8. Unclip the door trim panel (1) from the clips (2) using special tool 00 9 325, starting from the B-pillar area.

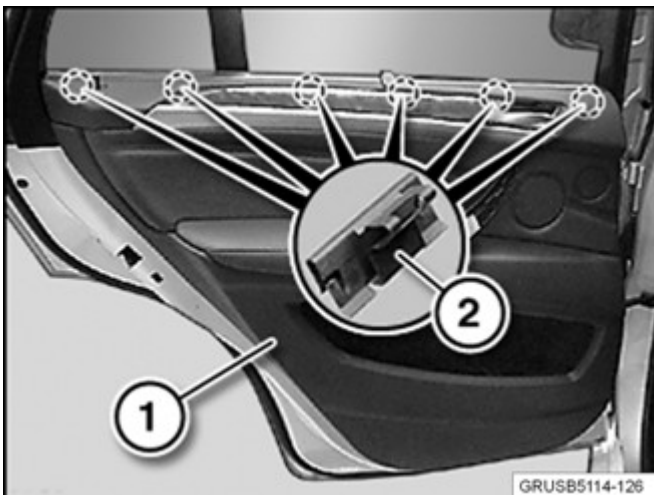

9. Carefully unclip the door trim panel (1) from the top retainers (2), and disconnect all plug connections.

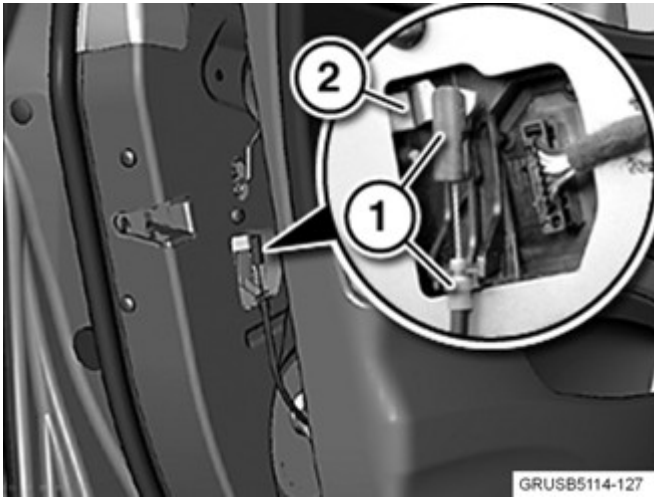

10. Unhook the Bowden cable (1) from the door lock (2).

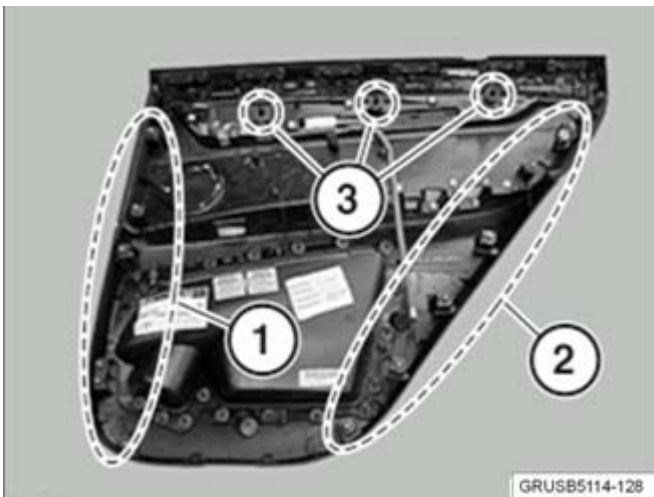

11. Note:
After each removal, all light blue clamps (2) must be replaced.

Installation note:

Replace any faulty clips (1 and 2).
Fit all clips with sealing rings.

Make sure the clips are installed in the correct position.

- 1 Grey clip
- 2 Light blue clip

Seals (3) must not be missing.

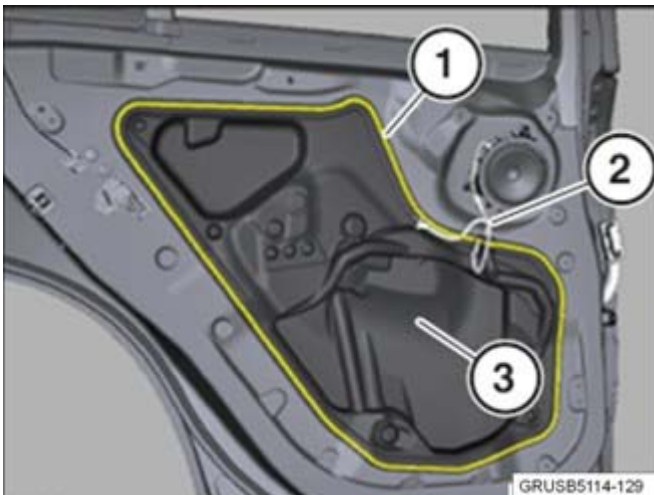

12. Note the position of the sealing bead (1).
Pay special attention to the cable (2) when removing the sound insulation (3).

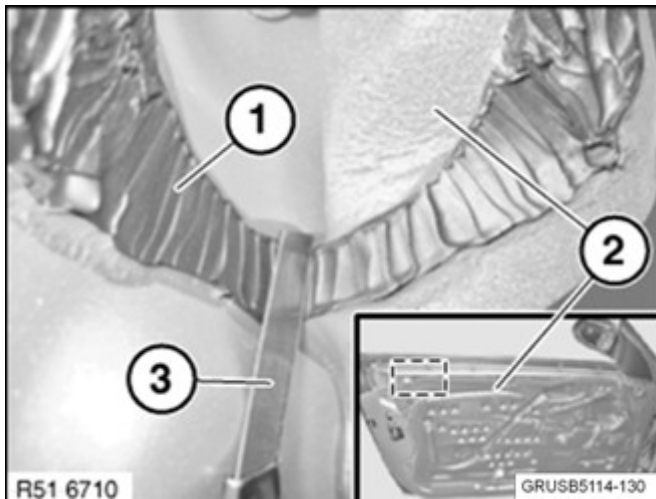

13. Important!

When cutting through the sealing bead (1), do not damage the sound insulation (2) or the cable. With a suitable sharp cutting tool (3), cut through the sealing bead (1) of the sound insulation (2) in the area to be detached.

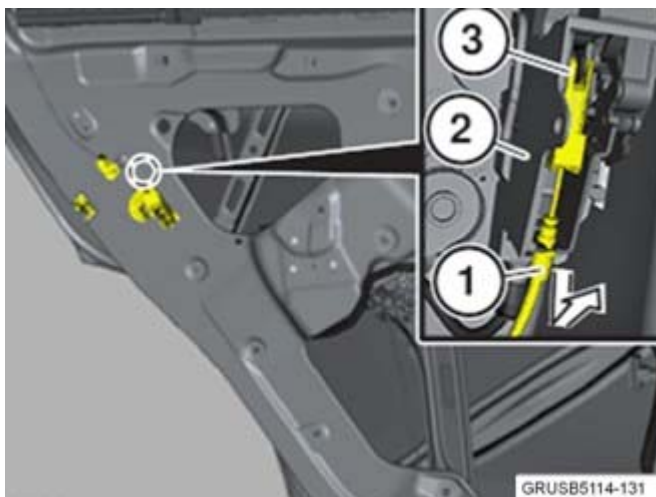

14. Disconnect the Bowden cable at the bottom (1) and top (3) from the door lock (2).

Installation note:

Pull the hook for the top cable (3) slightly downwards and hook on the cable. The Bowden cable must be correctly engaged in the locators of the door lock (2) and must be routed without kinking.

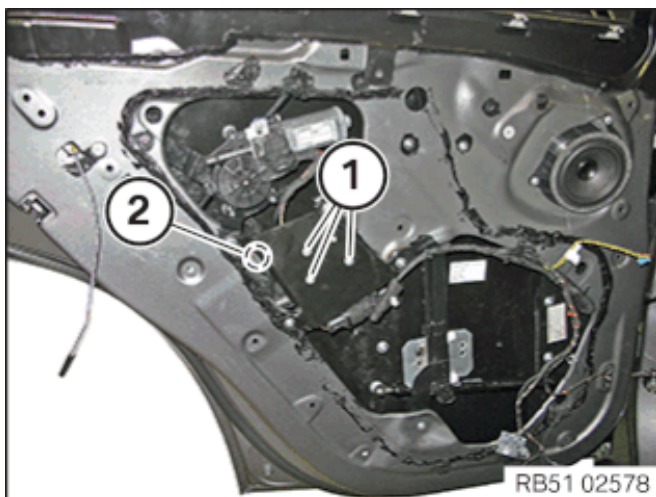

15. Remove the three screws (1). Unlock and disconnect the plug (2) on the drive unit, and carefully guide out the drive unit.

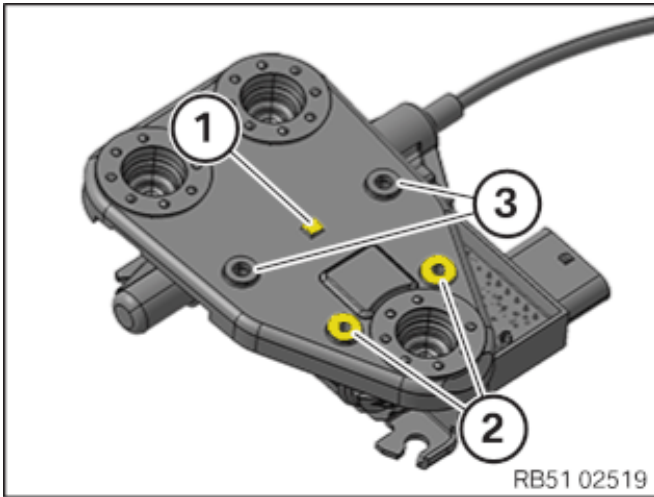

16. Replacement:
Remove the lug (1) and grind the lugs (2)
to the same height as the lugs (3).

Reinstall the removed parts in the reverse order of their removal.