



Technical Service Bulletin

46 Clicking noise from front brakes - Quattro models only

46 18 98 2044669/6 September 28, 2018. Supersedes Technical Service Bulletin Group 46 number 18-83 dated January 5, 2018 for reasons listed below.

Model(s)	Year	VIN Range	Vehicle-Specific Equipment
A4, A4 allroad	2016 - 2018	All	Quattro
A5, A5 Sportback, A5 Cabriolet, and Q5	2017 - 2018	All	Quattro

Condition

REVISION HISTORY		
Revision	Date	Purpose
6	-	Revised <i>Warranty</i> (Updated Labor Operations)
5	01/05/2018	Revised title (Updated) Revised header data (Added filter) Revised <i>Condition</i> (Updated note and moved from Service)
4	09/25/2017	Revised <i>Required Parts and Tools</i> (Added parts) Revised <i>Service</i> (Added note)

A clicking noise is heard from front brakes when the vehicle is being driven at low speeds (up to 10 mph) in either direction. For an example of the sound, see the video located at: <https://audi-external.kzoplatform.com/swf/player/322> (Figure 1).



Figure 1. QR code for viewing the video with a QR code reader on phones and tablets.



Technical Service Bulletin

Alternatively, the video can be accessed through computer internet browsers at the link provided in this bulletin.

Note:

This TSB does not apply to “S” models and front wheel drive models, due to the fact that these models are equipped with a different brake system.

Technical Background

The pads may be moving back and forth inside the caliper, which causes the noise.

Production Solution

Not applicable.

Service

Install new brake pads on both sides according to the instructions in the Elsa at Repair Manual, *Chassis >> Brake System >> 46 Mechanical Components >> Front Brakes >> Brake Pads Removing and Installing*. Read the following installation information before installing the new pads:

- The brake pistons must be clean. Brake cleaner can be used to clean the brake pistons. Ensure that the contact surfaces are free of dust and grease, and that they are dry (Figure 2).
- Only remove the protective paper from the adhesive foil on the brake pad (Figure 3) *immediately before* installation, and do not touch the adhesive surface.
- When installing the brake pads in the caliper, note that an arrow is printed on the pads to indicate the correct installation position in the caliper (Figure 4). The pads should be installed with the arrow following the forward rotation of the wheel.

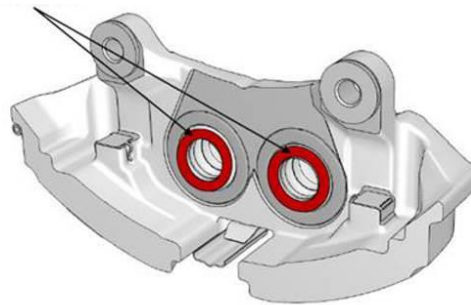

Figure 2. Contact surfaces of brake pistons.

Note:

After installing the pads, keep full brake pressure for about five seconds to ensure that the pads are properly bonded to the pistons.



Technical Service Bulletin

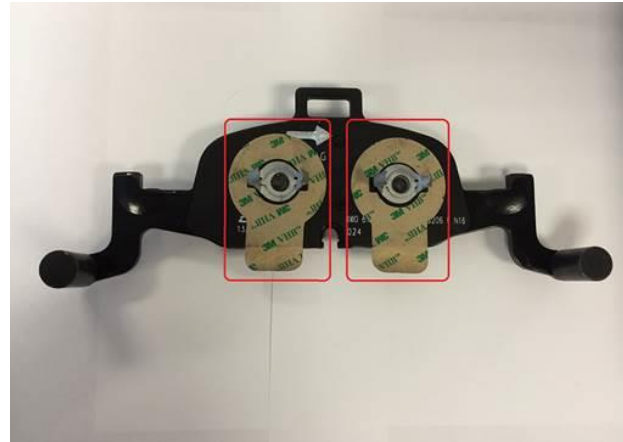

Figure 3. Protective paper to be removed immediately before installation.



Figure 4. Arrow showing correct installation direction.

Warranty

Claim Type:	<ul style="list-style-type: none">• 110 up to 48 Months/50,000 Miles.• If vehicle is outside any warranty, this Technical Service Bulletin is informational only.		
Service Number:	4636		
Damage Code:	0010		
Labor Operations:	2 Brake pads, front remove + reinstall	4636 2050	See SRT
	2 Wheels remove + reinstall	4405 2000	See SRT



Technical Service Bulletin

Diagnostic Time:	GFF	No allowance	0 TU
	Road test prior to service procedure	0121 0002	10 TU
	Road test after service procedure	0121 0004	10 TU
Claim Comment:	As per TSB #2044669/6		

All warranty claims submitted for payment must be in accordance with the *Audi Warranty Policies and Procedures Manual*. Claims are subject to review or audit by Audi Warranty.

Required Parts and Tools

Always check with your Parts Department and/or ETKA for the latest information and parts bulletins.		
Part Number	Part Description	Quantity
See ETKA	Contact for vehicles with brake pad wear indicator	01
See ETKA	Set of intermediate plate and spring clip	02
8W0698151T	Set of front brake pads	01
See ETKA	Fasteners, Bolts, Nuts and Screws as needed per the Repair Manual	See ETKA/ELSA

Additional Information

All parts and service references provided in this TSB (2044669) are subject to change and/or removal.

©2018 Audi of America, Inc. All rights reserved. Information contained in this document is based on the latest information available at the time of printing and is subject to the copyright and other intellectual property rights of Audi of America, Inc., its affiliated companies and its licensors. All rights are reserved to make changes at any time without notice. No part of this document may be reproduced, stored in a retrieval system, or transmitted in any form or by any means, electronic, mechanical, photocopying, recording, or otherwise, nor may these materials be modified or reposted to other sites without the prior expressed written permission of the publisher.