



David J. Johnson
Director
Service Engineering Operations
Ford Customer Service Division

Ford Motor Company
P. O. Box 1904
Dearborn, Michigan 48121

September 13, 2018

TO: All U.S. Ford and Lincoln Dealers

SUBJECT: **Customer Satisfaction Program 18N01 - Supplement #1**
Certain 2018 Model Year Expedition and Navigator Vehicles Equipped With R-1234yf
Refrigerant
Special R-1234yf Refrigerant Service Information

New! REASON FOR THIS SUPPLEMENT

Service Action Update: Dealers are no longer required to return the refrigerant recovery tanks. Refer to updated Attachments IV and V.

PROGRAM TERMS

This is a one-time repair program and DOES NOT apply to vehicles outside of New Vehicle Limited Warranty. Coverage is automatically transferred to subsequent owners.

AFFECTED VEHICLES

Vehicle	Model Year	Assembly Plant	Build Dates
Expedition	2018	Kentucky Truck	January 2, 2018 through February 6, 2018
Navigator	2018	Kentucky Truck	January 2, 2018 through February 6, 2018

Affected vehicles are identified in OASIS.

REASON FOR THIS PROGRAM

This program provides special service instructions, loaner equipment, and rental assistance to expedite the repair of affected vehicles equipped with R-1234yf A/C refrigerant, which may be contaminated.

NOTE: DO NOT connect an A/C recovery machine or pressure gauges to the vehicle unless directed by this article, as damage to the equipment may result.

SERVICE ACTION

If a vehicle equipped with R-1234yf refrigerant, with a build date between January 2, 2018 and February 6, 2018, exhibits a lack of A/C cooling with no associated DTCs, or requires recovery of R-1234yf A/C refrigerant to complete a service repair, dealers are to obtain the equipment from Ford Motor Company necessary to evacuate the A/C system. Once the refrigerant has been evacuated, dealers will replace the A/C components identified in this bulletin and recharge the system following the instructions in Attachment III. This includes, but is not limited to damage caused by collision or other. This service must be performed at no charge to the vehicle owner.

NOTE: To obtain the loaner equipment, dealers are to submit a VIN-specific contact via the Special Service Support Center (SSSC) web contact site. Follow the on-line instructions and complete the bailment agreement. The SSSC web contact site can be accessed through the Professional Technician Society (PTS) website using the SSSC link listed at the bottom of the OASIS VIN report screen or listed under the SSSC tab.

OWNER NOTIFICATION MAILING SCHEDULE

Owner Letters will not be mailed for this program.

New! ATTACHMENTS

Attachment I: Administrative Information
Attachment II: Labor Allowances and Parts Ordering Information
Attachment III: Technical Information
Attachment IV: Dealer Bailment Agreement
Attachment V: Contaminated Refrigerant Recovery Loaner Equipment User Instructions

QUESTIONS & ASSISTANCE

For questions and assistance, contact the Special Service Support Center (SSSC) via the SSSC Web Contact Site. The SSSC Web Contact Site can be accessed through the Professional Technician Society (PTS) website using the SSSC link listed at the bottom of the OASIS VIN report screen or listed under the SSSC tab.

Sincerely,



David J. Johnson

Customer Satisfaction Program 18N01 - Supplement #1

Certain 2018 Model Year Expedition and Navigator Vehicles Equipped With R-1234yf Refrigerant
Special R-1234yf Refrigerant Service Information

OASIS ACTIVATION

OASIS will be activated on July 20, 2018.

FSA VIN LISTS ACTIVATION

FSA VIN Lists will not be activated for this service action.

SOLD VEHICLES

Dealers are to prioritize repairs of customer vehicles over repairs of new and used vehicle inventory.

STOCK VEHICLES

Do not perform this program unless the affected vehicle exhibits the covered condition.

TITLE BRANDED / SALVAGED VEHICLES

Vehicles with cancelled warranties are not eligible for this service action.

OWNER REFUNDS

Refunds are not approved for this program.

RENTAL VEHICLES

Dealers are pre-approved for up to ten days for a comparable rental vehicle. The rental rate for Expedition is \$60.00 per day, and Navigator is \$72.00 per day. Rentals will only be reimbursed for the days the vehicle is at the dealership for part replacement. Prior approval for more than ten rental days is required from the SSSC via the SSSC Web Contact Site.

LINCOLN CLIENT SPECIAL HANDLING

To ensure the best possible experience for Lincoln owners, Lincoln Dealers are encouraged to utilize the Lincoln Loyalty Program to provide clients with surprise and delight offerings, such as:

- Fuel fill
- Gift Card for the client's favorite restaurant
- Transportation assistance
- Courtesy pick-up and delivery of client vehicles

The Lincoln Loyalty Program is exclusive to Lincoln Dealers. Owners will not be notified of this service in owner mailings. Reference EFC06196, Lincoln Loyalty Program Announcement for additional details.

Customer Satisfaction Program 18N01 - Supplement #1

Certain 2018 Model Year Expedition and Navigator Vehicles Equipped With R-1234yf Refrigerant
Special R-1234yf Refrigerant Service Information

ADDITIONAL REPAIR (LABOR TIME AND/OR PARTS)

Additional repairs identified as necessary to complete the FSA should be managed as follows:

- For related damage and access time requirements, refer to the Warranty and Policy Manual – Section 6 – Ford/Lincoln Program Policies – Field Service Actions (FSA) – Related Damage.

CLAIMS PREPARATION AND SUBMISSION

- Enter claims using Dealer Management System (DMS) or One Warranty Solution (OWS) online.
 - When entering claims, select claim type 31: Field Service Action. The FSA number (18N01) is the sub code.
 - For additional claims preparation and submission information, refer to the Recall and Customer Satisfaction Program (CSP) Repairs in the OWS User Guide.
- Additional labor and/or parts must be claimed as related damage on a separate repair line from the FSA. **IMPORTANT:** Click the radio button on the Related Damage Indicator.
- Provision for Misc. Expense: Motorcraft Refrigerant.
 - Program Code: 18N01
 - Misc. Expense: OTHER
 - Amount: Actual cost up to \$315.00
- For rental vehicle claiming, the rental rate for Expedition is \$60.00 per day, and Navigator is \$72.00 per day. Enter the total amount of the rental expense under Miscellaneous Expense code RENTAL.
- For Lincoln Client Special Handling, reference EFC06196, Lincoln Loyalty Program Announcement and EFC04165, Lincoln Loyalty Rental Claims for Requirements and Claiming Instructions. Claims for Lincoln Loyalty should be submitted as a separate line on the same Repair Order.

Customer Satisfaction Program 18N01 - Supplement #1

Certain 2018 Model Year Expedition and Navigator Vehicles Equipped With R-1234yf Refrigerant
Special R-1234yf Refrigerant Service Information

LABOR ALLOWANCES

Description	Labor Operation	Labor Time
Expedition 4X2: Evacuate Contaminated Refrigerant, Replace affected A/C Components Following The Service Procedure	18N01B	12.9 Hours
Expedition 4X4: Evacuate Contaminated Refrigerant, Replace affected A/C Components Following The Service Procedure	18N01C	13.1 Hours
Navigator 4X2: Evacuate Contaminated Refrigerant, Replace affected A/C Components Following The Service Procedure	18N01D	14.2 Hours
Navigator 4X4: Evacuate Contaminated Refrigerant, Replace affected A/C Components Following The Service Procedure	18N01E	14.4 Hours

PARTS REQUIREMENTS / ORDERING INFORMATION

Part Number	Description	Order Quantity	Claim Quantity
HL3Z-19712-A	Condenser	1	1
JL1Z-19703-AB	Compressor	1	1
DS7Z-19B596-A	Compressor Assembly Gasket	1	1
HL3Z-19849-C	Thermostatic Expansion Valve	1	1
HL3Z-19B596-A	O-Ring Kit	1	1
HL3Z-19867-M	Compressor Inlet Line	1	1
JL1Z-19972-AA	Compressor Outlet Line	1	1
JL1Z-19A834-BA	Thermostatic Expansion Valve Manifold and Tube Assembly	1	1
JL1Z-19E631-AA	Compressor Outlet Jumper Line	1	1
HL3Z-19850-GF	Dual Zone Evaporator Case (Only For Dual Zone Climate Control)	1	1
HL3Z-19850-FF	Single Zone Evaporator Case (Only For Single Zone Climate Control)	1	1
JL1Z-19867-CA	Rear Evaporator Rear Outlet and Inlet Line (Short Wheel Base Only)	1	1
JL1Z-19867-DA	Rear Evaporator Rear Outlet and Inlet Line (Long Wheel Base Only)	1	1
YN-33-A	Refrigerant	Claim as MISC. OTHER	
JL1Z-19850-AG	Rear Climate Control Housing Assembly	1	1

Customer Satisfaction Program 18N01 - Supplement #1

Certain 2018 Model Year Expedition and Navigator Vehicles Equipped With R-1234yf Refrigerant
Special R-1234yf Refrigerant Service Information

W520514-S440	Catalytic Converter Nut	4	4
W520114-S442	Transmission Crossmember Support Hex Nut	4	1
W714418-S439	Transmission Crossmember Support Bolt	2	1
W717218-S442	Steering Column Hex Flanged Bolt	1	1
W719352-S451	Front Seat Bolt	4	1
W718633-S451	Rear Front Seat Bolt	4	1
W716538-S450B	Nut And Washer Assembly – Hex (Navigator Only)	2	1
W712250-S437	Bolt (Navigator Only)	2	2
W711140-S900	Transmission Mount Bolt (4x2 Only)	3	3
W718353-S900	Transmission Mount Bolt (4x4 Only)	4	1

Order your parts requirements through normal order processing channels. To guarantee the shortest delivery time, an emergency order for parts must be placed.

DEALER PRICE

For latest prices, refer to DOES II.

PARTS RETENTION AND RETURN

Follow the provisions of the Warranty and Policy Manual, Section 1 - WARRANTY PARTS RETENTION AND RETURN POLICIES.

EXCESS STOCK RETURN

Excess stock returned for credit must have been purchased from Ford Customer Service Division in accordance with Policy Procedure Bulletin 4000.



Customer Satisfaction Program 18N01 - Supplement #1
Certain 2018 Model Year Expedition and Navigator Vehicles Equipped With R-1234yf Refrigerant
Special R-1234yf Refrigerant Service Information

**FORD MOTOR COMPANY
EQUIPMENT LOAN AGREEMENT**

RECITALS

- A. Ford is willing to lend to Borrower certain equipment ("Equipment") described in Paragraph 1 hereof for the purpose of recovering contaminated R-1234yf refrigerant on a Ford or Lincoln vehicle.
- B. Borrower is willing to accept the Equipment and use it for the purpose and in accordance with the terms and conditions of this Agreement.

TERMS & CONDITIONS

- 1. **Bailment.** Ford and Borrower agree that this Agreement shall constitute a bailment of the Equipment to Borrower. Ford hereby lends the following Equipment to the Borrower to be held and used by Borrower, as a Bailee of the Equipment, in accordance with this Agreement:

<u>ITEM</u>	<u>DESCRIPTION</u>
Rotunda item #218-TRSA30	Contaminated refrigerant recovery machine with hoses and fittings
Rotunda item #218-HS3B	3' standard A/C charge hose
Rotunda item #218-CRX430TS	30 lb. refrigerant recovery tank w/float ¹
Rotunda item #218-ARXF6	Liquid line filter drier ¹

¹ *Follow return instructions included with equipment or as specified in Attachment V. Do not return refrigerant recovery tanks and liquid line filter drier (refrigerant filter), dispose of in accordance with local regulations.*

- 2. **Location and Title.** Borrower shall utilize the Equipment in the dealership service area for the purpose of recovering contaminated R-1234yf refrigerant on a Ford or Lincoln vehicle. The Equipment shall remain the property of Ford. The Equipment shall at all times be properly used and maintained by Borrower and shall be marked "Property of Ford Motor Company". The Equipment shall not be removed from the area referred to above, without Ford's prior written approval, for any reason other than for delivery to Ford. Upon request by Ford, the Equipment shall be immediately delivered to Ford. Ford shall have the right to enter onto Borrower's premises at all reasonable times to inspect the Equipment and Borrower's records with respect thereto.

Customer Satisfaction Program 18N01 - Supplement #1

Certain 2018 Model Year Expedition and Navigator Vehicles Equipped With R-1234yf Refrigerant
Special R-1234yf Refrigerant Service Information

3. Indemnity. Borrower shall defend, indemnify, and save harmless Ford and its subsidiaries and their respective officers, directors, agents, and employees (hereinafter collectively called "Indemnitees") from and against any and all losses, damages, claims, actions, costs and expenses, including, but not limited to, fees and expenses of legal counsel and expert witnesses, that may be imposed upon or incurred by or asserted or entered against the Indemnitees, or any of them, by reason of actual or alleged:

(i) injury to or death of persons (including, without limitation, any employee or employees of one or more of the Indemnitees or of Borrower or of one or more of its contractors, subcontractors, vendors or agents);

(ii) loss of or damage to the property of any person or legal entity (including, without limitation, any property of any employee or employees of one or more of the Indemnitees or of Borrower or of one or more of its contractors, subcontractors, vendors or agents); or

(iii) violation of any law, ordinance or regulation of any governmental authority (including, without limitation, the United States of America or any of its states or localities, or Canada or any of its provinces or localities) by Borrower or by any of its contractors, subcontractors, vendors, agents or employees;

as a result of or arising out of or in connection with the possession or use, by or on behalf of Borrower, of the Equipment, or the condition thereof; provided, however, that the foregoing agreement to indemnify and hold the Indemnitees harmless shall not be applicable to the extent that any such loss, damage, claim, action, suit, judgment, decree, order, cost or expense are attributable to the sole negligence or the willful or wanton misconduct of the Indemnitees. Borrower shall promptly notify Ford of any event covered by this Paragraph of which Borrower has actual notice, and Ford shall be entitled to participate in the defense of any claim for expenses.

4. Insurance. Borrower, at its sole cost and expense, shall procure and maintain during the term of this Agreement, from insurers listed in a current "Bests Insurance Guide" as possessing minimum policyholder's rating of "A-" and a financial category of "VI", commercial automobile liability and commercial general liability insurance covering body injury liability and property damage liability, including broad form property damage liability and contractual liability coverage (either a blanket policy or a policy applying specifically to this Agreement), with limits of not less than \$3 million combined single limit per occurrence of loss or damage. Such insurance coverage shall protect the Borrower, Ford and any person using, operating or otherwise having an interest in the Equipment and shall also meet the requirements of any so-called "no-fault" law now in effect or which hereafter may be enacted.

Customer Satisfaction Program 18N01 - Supplement #1

Certain 2018 Model Year Expedition and Navigator Vehicles Equipped With R-1234yf Refrigerant
Special R-1234yf Refrigerant Service Information

Such insurance policy shall name Ford as an additional insured and shall provide that the policy may not be canceled or materially altered without 30 days prior written notice to Ford. The insurance provided by Borrower will be primary insurance and will not be excess to or contributory with respect to insurance coverage, if any, provided by Ford. In addition, Ford shall be named as an additional insured on any excess or umbrella program purchased or maintained by Borrower.

At or before delivery of the Equipment to Borrower, Borrower shall provide Ford with acceptable evidence of insurance coverage in accordance with this Agreement by delivering certified copies of insurance policies that provide the required coverage, or certified copies of existing insurance policies that have been endorsed to provide the required coverages, or certificates of insurance executed by the insurer or its authorized representative that certify the required coverages. The furnishing of such insurance shall not relieve Borrower from any liability or obligation for which it is otherwise responsible to Ford. Ford shall be under no duty to examine any certificate provided by Borrower or to advise Borrower that its insurance coverage does not comply with the requirements set forth herein.

5. Maintenance and Repairs. Borrower shall inspect the Equipment upon delivery and by acceptance thereof is deemed to find the Equipment in good working order and condition. Borrower or its designee shall maintain the Equipment in good working order and condition, properly serviced and greased, and comply in every respect with the provisions of Paragraph 10 hereof, and of the manufacturer's owner manual that came with the Equipment. Ford or its designee shall make all major repairs necessary to maintain the Equipment in good working order and condition. Title to all such repairs shall vest in Ford. All repairs and servicing shall be done by qualified service personnel except that warranty work, to the extent practicable, shall be done at the shop of the nearest authorized dealer in such make of the Equipment. Borrower shall pay for all gasoline, oil and normal service required for the proper operation of the Equipment and for all washing, parking, garage, highway road service, tolls and fines required or incurred in connection with the operation of the Equipment.
6. Delivery and Return of Equipment. Ford shall be responsible for delivery of the Equipment to Borrower. Ford shall not be responsible for any delay in delivery of the Equipment. Borrower shall return the Equipment to Ford, at a location designated by Ford, no longer than two weeks after receipt of the Equipment, unless otherwise specified by Ford.

Customer Satisfaction Program 18N01 - Supplement #1

Certain 2018 Model Year Expedition and Navigator Vehicles Equipped With R-1234yf Refrigerant
Special R-1234yf Refrigerant Service Information

7. Use of Equipment. Borrower shall utilize the Equipment for the purpose of recovering contaminated R-1234yf refrigerant on a Ford or Lincoln vehicle as specified by Ford. Borrower shall not use or operate the Equipment in violation of any federal, state, local or provincial law, rule, regulation or ordinance including those pertaining to the age and licensing of drivers, the disclosure of Ford's interest in the Equipment, or other requirements or limitations. Under no circumstances shall Borrower disconnect any odometer or other mileage recording device nor shall the Equipment be used or operated (a) in a manner subjecting it to depreciation above the normal depreciation associated with general commercial use, (b) for any illegal purpose or by a person under the influence of alcohol or narcotics, (c) in any manner or for any purpose that would cause any insurance specified in this Agreement to be suspended, cancelled, held inapplicable or increased in cost, or (d) outside the continental United States or Canada without Ford's express written permission. The Equipment shall be operated at all times in a safe, careful and lawful manner and by qualified operators. The Equipment may be operated only by persons who are employees of the Borrower and stand in relations to the Borrower as employee to employer. Further, the operation of the Equipment shall be conducted under the exclusive supervision, direction and control of Borrower. Under no circumstances shall an employee of Borrower be considered or held out as an agent, servant or employee of Ford.
8. Inspection and Reports. Borrower agrees to allow Ford to inspect the Equipment and to otherwise observe it in operation at such time and facility as Ford may specify. Borrower shall provide Ford with such mileage, maintenance, safety, operating or other information or copies of any such records maintained by Borrower with respect to the Equipment as Ford or any governmental agency may require from time to time.
9. Risk of Loss. Borrower shall assume all risks of loss with respect to the Equipment, including loss or damage that occurs despite Borrower's exercise of reasonable care, but excluding normal wear and tear, from the time it is delivered by Ford to Borrower and until the Equipment has been returned to Ford at the location Ford designates. In the event of damage to the Equipment, Borrower shall notify Ford to that effect and follow such instructions as Ford may provide with respect to repair or disposal of the Equipment. Borrower shall be responsible for payment of any repairs to the extent not covered by insurance inuring to the benefit of Ford. If any Equipment is lost, stolen, destroyed or is declared a total constructive loss (subject to Ford's agreement as to such condition), Borrower shall promptly notify Ford thereof and hold any wreckage for disposal by Ford. With respect to any lost, stolen, or destroyed Equipment, Borrower shall pay Ford (to the extent not covered by insurance inuring to the benefit of Ford) an amount equal to the wholesale market value for comparable Equipment in a condition similar to the lost, stolen or destroyed Equipment immediately prior to any such loss.

Customer Satisfaction Program 18N01 - Supplement #1

Certain 2018 Model Year Expedition and Navigator Vehicles Equipped With R-1234yf Refrigerant
Special R-1234yf Refrigerant Service Information

10. Procedures on Accidents. Within 24 hours of an accident, theft or conversion of any Equipment, Borrower shall file a written report to that effect with Ford and the insurer of such Equipment. Borrower shall promptly notify and furnish Ford with every demand, notice, summons, process and pleading received in every suit, action or claim arising with respect to the condition, use or operation of the Equipment, and cooperate with Ford and the insurer in defending the same. Ford reserves the right to examine any such Equipment.
11. Termination. Ford may terminate this Agreement at any time by giving 30 days prior written notice to Borrower, except that Ford may terminate this Agreement effective immediately upon written notice to Borrower, in the event Borrower fails to provide or maintain any insurance required hereunder, or in the event of the filing of any petition by or against Borrower under any bankruptcy, reorganization, receivership law, or Borrower's making an assignment for the benefit of creditors, or if Borrower makes or suffers any voluntary or involuntary assignments, or attachment, lien, or levy is made of or attached to the Equipment, or in the event Borrower otherwise fails to adhere to the terms and conditions of this Agreement. Borrower may terminate this Agreement at any time by giving 30 days prior written notice to Ford. Upon termination by either party, Borrower shall make all Equipment immediately available for return to Ford. The obligations and rights provided in Paragraphs 3, 9, 13 and 14 shall survive termination of this Agreement.
12. Assignment. Borrower is expressly prohibited from assigning this Agreement or delegating performance of any of its obligations hereunder without the prior written consent of Ford. Ford shall not be prohibited from selling, assigning, transferring or otherwise encumbering any interest or right hereunder with respect to the Equipment. Nothing contained herein shall be interpreted as releasing Borrower from any of its obligations as specified in this Agreement.
13. Publicity. Neither party hereto shall identify the other party as a joint venturer or partner or otherwise characterize the arrangement between them as anything other than a bailment. Borrower shall not disclose or publicize to any third party: (a) any description of the Equipment, technical specifications or other information about the Equipment; (b) the nature or terms of this Agreement; or (c) the results of any testing, inspection or evaluation of the Equipment by Ford or Borrower without Ford's prior written consent. Borrower shall take the necessary steps to familiarize all appropriate employees of Borrower of its obligations under this Paragraph.

Neither party shall use the other's name or logos, in whole or in part, for any purpose whatsoever, specifically including but not limited to any written, oral or pictorial endorsement, testimonial or advertisement, whether actual or implied, without such other party's prior written approval.

Customer Satisfaction Program 18N01 - Supplement #1

Certain 2018 Model Year Expedition and Navigator Vehicles Equipped With R-1234yf Refrigerant
Special R-1234yf Refrigerant Service Information

14. Force Majeure and No Consequential Damages. Ford shall not be liable for any failure in performing any provision hereof due to fire or other casualty, labor difficulty, governmental restriction or any cause beyond Ford's control. Borrower specifically warrants that the Equipment is not critical to the operation of its business and the loss of use of such Equipment, for any reason whatsoever, will not have a material adverse effect on its business. IN NO EVENT SHALL FORD BE LIABLE FOR ANY LOSS OF PROFITS, OTHER CONSEQUENTIAL DAMAGES OR INCONVENIENCE DUE TO EARLY TERMINATION OF THIS AGREEMENT, OR ANY THEFT, DAMAGE, LOSS, DELAY OR FAILURE OF DELIVERY OR DEFECT OR FAILURE OF THE EQUIPMENT, OR THE TIME CONSUMED IN RECOVERING, REPAIRING, SERVICING OR REPLACING THE SAME.
15. Governing Law. This Agreement will be governed by and construed and interpreted in accordance with the laws of the State of Michigan.
16. Entire Agreement, Waiver and Notice. This Agreement constitutes the entire agreement between the parties and may only be amended, modified or supplemented by a written amendment executed by Ford and Borrower. Failure by Ford to enforce any term, provision or condition hereof, or to exercise any of its rights hereunder, shall not be construed as thereafter waiving any such terms, provisions, conditions or rights. In no event shall any course of dealing, custom or usage of trade modify, alter or supplement any of the terms or provisions contained herein. All notices specified or permitted herein shall be in writing, mailed postpaid U.S. mail, or courier service, with return receipt requested.
17. Additional Attachments: The following Attachments (if any) are incorporated into this Agreement by reference: none. To the extent that a provision of an Attachment conflicts with a provision of this Agreement, THIS AGREEMENT SHALL SUPERSEDE THE ATTACHMENT.

Execution of this document indicates agreement with the terms stated above and acceptance of the Equipment in good condition. The person signing for the Borrower warrants and represents that he or she is an officer or agent of the Borrower and is authorized to execute this Agreement on its behalf. IN WITNESS WHEREOF, the parties hereto have caused this Agreement to be executed by their authorized representatives as of the date indicated in the request form.

Customer Satisfaction Program 18N01 - *Supplement #1*

Certain 2018 Model Year Expedition and Navigator Vehicles Equipped With R-1234yf Refrigerant
Special R-1234yf Refrigerant Service Information



Contaminated Refrigerant Recovery Loaner Equipment

Ford and Lincoln Dealership User Instructions
September 2018

Customer Satisfaction Program 18N01 - Supplement #1

Certain 2018 Model Year Expedition and Navigator Vehicles Equipped With R-1234yf Refrigerant
Special R-1234yf Refrigerant Service Information

**Box 1 Contents:**

1. Refrigerant recovery machine
2. Yellow refrigerant hose
3. Red refrigerant hose
4. Blue refrigerant hose
5. Refrigerant fittings (2)
6. Dealer bailment agreement
7. Dealer setup instructions
8. Manufacturer operating instructions
9. Return Shipping Label

Box 2 Contents:

1. Refrigerant Recovery Tank
2. Refrigerant filter

- Unpack both boxes
- Keep Box 1 including all packaging materials and return shipping label

Customer Satisfaction Program 18N01 - Supplement #1
Certain 2018 Model Year Expedition and Navigator Vehicles Equipped With R-1234yf Refrigerant
Special R-1234yf Refrigerant Service Information



Assemble as shown.

See details on pages 3-5.

Customer Satisfaction Program 18N01 - Supplement #1

Certain 2018 Model Year Expedition and Navigator Vehicles Equipped With R-1234yf Refrigerant
Special R-1234yf Refrigerant Service Information

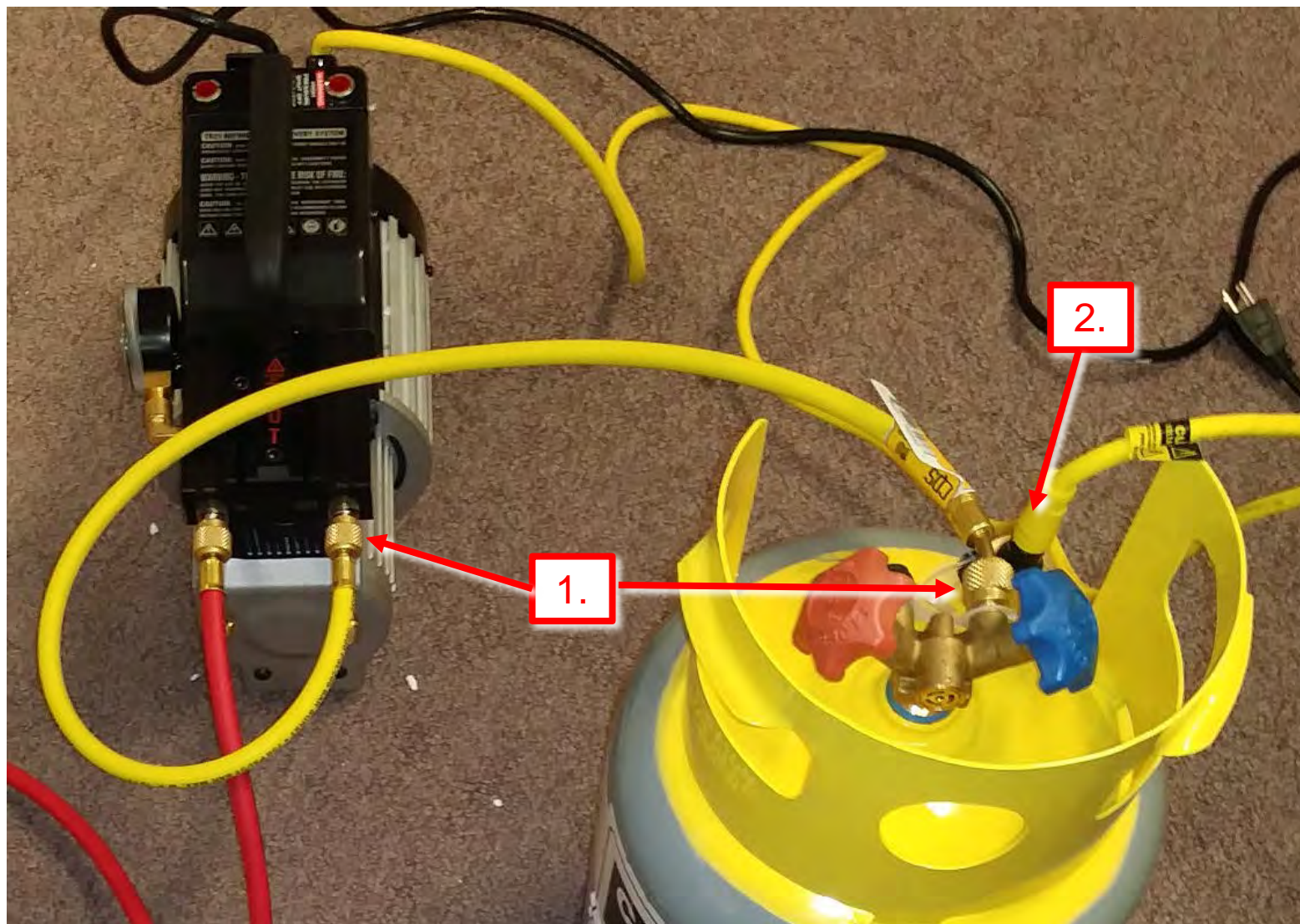

1. Connect the yellow hose from recovery machine Out to the low side (blue) port on the recovery tank.
2. Connect the high pressure cut-off switch from the recovery machine to the recovery tank.

Customer Satisfaction Program 18N01 - Supplement #1
 Certain 2018 Model Year Expedition and Navigator Vehicles Equipped With R-1234yf Refrigerant
 Special R-1234yf Refrigerant Service Information

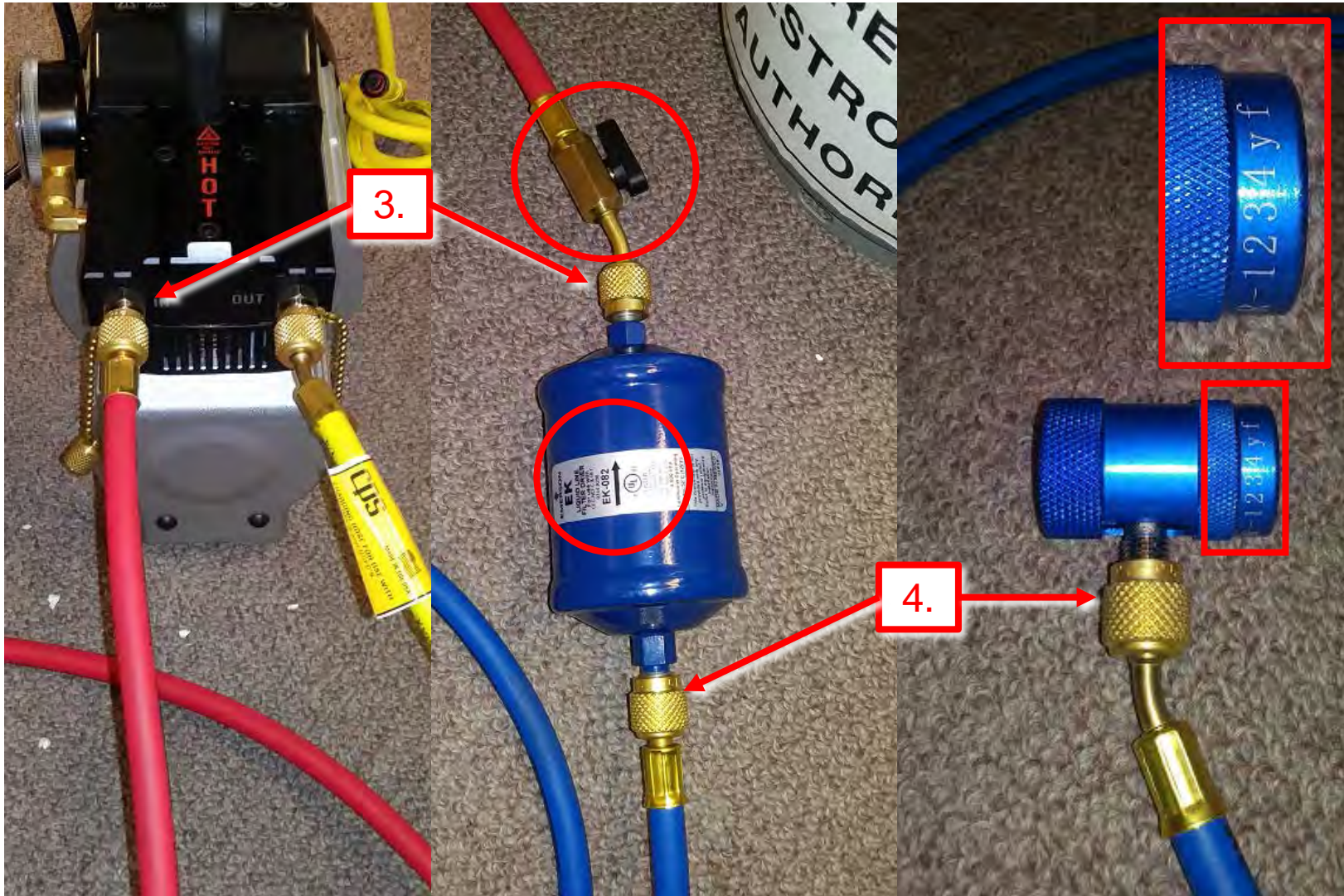

3. Connect the red hose from the recovery machine In to the refrigerant filter Out port.

NOTE: ensure that the valve on the red hose is in the Open position (parallel to the hose).

NOTE: the arrow on the refrigerant filter should point toward the recovery machine/red hose.

4. Connect the blue hose from the refrigerant filter In to the R-1234yf coupler.

NOTE: The recovery machine comes with two couplers; use only the R-1234yf coupler.

- **Connect the R1234yf coupler to the low side service port on the vehicle**
- **Connect the recovery machine electrical supply.**
- **Open the low side valve (blue knob) on the recovery tank.**
- **Turn on the recovery machine and allow it to run for 25 minutes.**
- **Close the low side valve (blue knob) on the recovery tank.**
- **Turn off the recovery machine and disconnect the electrical supply.**
- **The refrigerant has been recovered and the vehicle can be repaired.**

- **Return the appropriate equipment to Box 1 as it was received.**
- **Apply the return shipping label provided to Box 1 and return the equipment.**
- ***Refrigerant recovery tank can be kept to service additional vehicles affected by this recall if required (one refrigerant recovery tank can reclaim the refrigerant from up to 8 vehicles)***
- ***Dispose of the contaminated refrigerant recovery tank in accordance with local regulations when full or if no additional vehicles require repair.***
- ***The refrigerant filter can be disposed of in the regular trash.***

NOTE: Normal warranty parts return process for 700 tags does apply for this program.



CERTAIN 2018 MODEL YEAR EXPEDITION AND NAVIGATOR VEHICLES EQUIPPED WITH R-1234YF REFRIGERANT - SPECIAL R-1234YF REFRIGERANT SERVICE INFORMATION

OVERVIEW

This program provides special service instructions, loaner equipment, and rental assistance to expedite the repair of affected vehicles equipped with R-1234yf A/C refrigerant, which may be contaminated.

NOTE: DO NOT connect an A/C recovery machine or pressure gauges to the vehicle unless directed by this article, as damage to the equipment may result. If a vehicle equipped with R-1234yf refrigerant, with a build date between January 2, 2018 and February 6, 2018, exhibits a lack of A/C cooling with no associated DTCs, or requires recovery of R-1234yf A/C refrigerant to complete a service repair, dealers are to obtain the equipment from Ford Motor Company necessary to evacuate the A/C system. Once the refrigerant has been evacuated, dealers will replace the A/C components identified in this bulletin and recharge the system following the instructions in Attachment III. This includes, but is not limited to damage caused by collision or other. This service must be performed at no charge to the vehicle owner.

NOTE: To obtain the loaner equipment, dealers are to submit a VIN-specific contact via the Special Service Support Center (SSSC) web contact site. Follow the on-line instructions and complete the bailment agreement. The SSSC web contact site can be accessed through the Professional Technician Society (PTS) website using the SSSC link listed at the bottom of the OASIS VIN report screen or listed under the SSSC tab.

SERVICE PROCEDURE

Recommended Tool List For Replacement:

General Tools	General Equipment
1/4" Drive 3 Inch Extension	Pry Bar 12"
1/4" Drive Deep Sockets 10mm and 11mm	Right Angle Pick 6"
1/4" Drive Standard Sockets 5.5mm, 7mm, 8mm	Motion Pro Torque Adapter
3/8" Drive Extensions 3", 10" and 24"	Plastic Trim Tool
3/8" Drive Deep Sockets 13mm and 15mm	Metal Push Pin Tool
3/8" Drive Swivel Socket 15mm	1/2" Breaker Bar
3/8" Drive Standard Sockets 10mm, 13mm, 15mm	
3/8" External Torx Plus 18mm	Recovery Equipment
1/2" Drive Standard Sockets 18mm and 21mm	Recharge Equipment
1/2" Drive Torx T55	
Torque Wrenches 1/4", 3/8" and 1/2" Drive	
Power Tools 1/4", 3/8" and 1/2" Drive	
Wrenches 1&1/8", 10mm, 16mm, 18mm	
Ratcheting Wrench 15mm	
Crows Foot 3/8" Drive 15mm and 19mm	
Medium Length Flat Blade Screwdriver	



NOTICE: Keep all caps on new A/C components until time of connection, also cover up RH turbocharger housing after Charge Air Cooler (CAC) intake pipe removal.

1. Is the vehicle equipped with R-1234yf refrigerant? Vehicle build information can be verified in PTS under vehicle Information, then click on Additional Information. If equipped, build information will equal G3FAD - A/C REFRIGERANT- HF01234YF:
 - A. No, this program does not apply.
 - B. Yes, proceed to step 2.

2. Does vehicle have a production build date between January 2, 2018 and February 6, 2018?
 - A. No, this program does not apply.
 - B. Yes, proceed to step 3.

3. Does vehicle exhibit a lack of A/C cooling with no associated DTCs, or does vehicle require recovery of R-1234yf refrigerant to complete a service repair?
 - A. No, this program does not apply.
 - B. Yes, proceed to step 4.

4. Obtain the equipment from Ford Motor Company necessary to evacuate the A/C system by submitting a VIN-specific contact via the SSSC web contact site the SSSC web contact site can be accessed through the PTS website using the SSSC link listed at the bottom of the OASIS VIN report screen or listed under the SSSC tab.

5. Once Loaner equipment has arrived, unpack the boxes and keep all boxes and packing material for return shipping.

6. Evacuate the A/C system.
 - A. Use one refrigerant recovery tank per vehicle, as samples from each vehicles will be needed for lab analysis.
 - B. Refer to Dealer Setup Instructions (a copy will be in the box with the equipment and is also 18N01 Attachment V).



⚠ IMPORTANT!: Do not connect contaminated components to the new replaced components. Only connect new replaced components to other new replaced components for the A/C system.

Underhood A/C Component Replacement All Vehicles.

7. Position the front seats to access the front seat bolts for removal.
8. Open the liftgate.
9. Depower the Supplemental Restraint System (SRS). Please refer to Workshop Manual (WSM) procedures in section 501-20B.
10. Remove the battery and battery tray. Please refer to WSM procedures in section 414-01.
11. Remove the engine cover. See Figure 1.

NOTE: Expedition shown, Navigator similar.

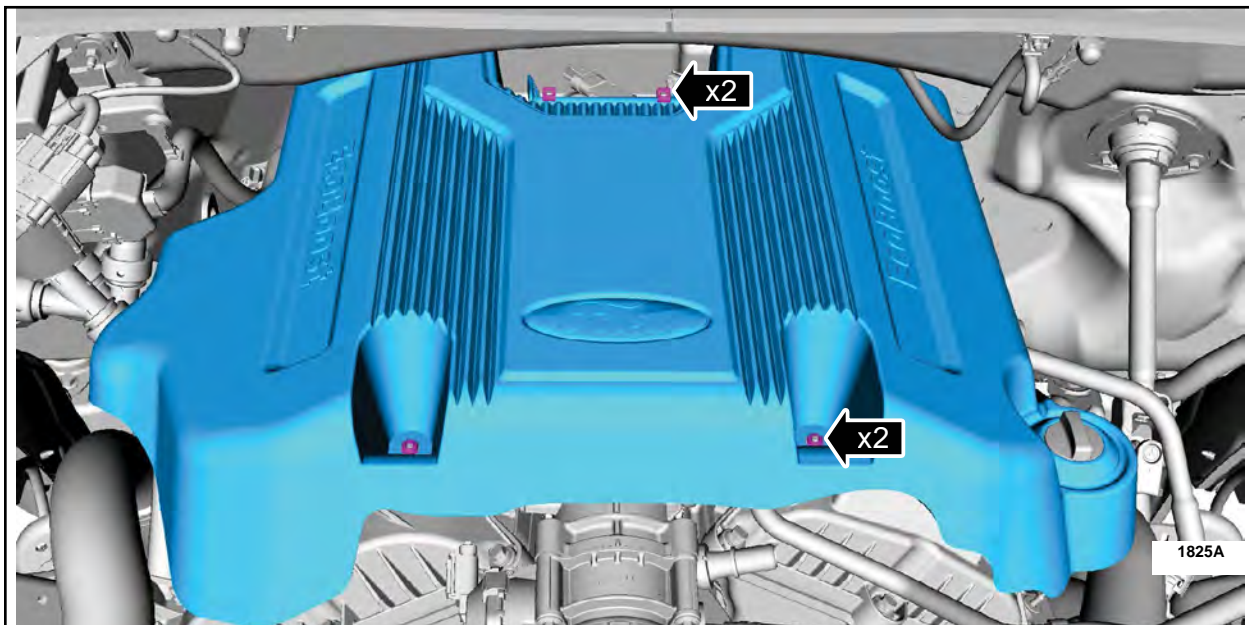

FIGURE 1

12. Replace the A/C Compressor. Please refer to WSM procedures in section 412-00.
13. Replace the A/C Compressor Outlet Line. Please refer to WSM procedures in section 412-00.



14. Replace the A/C Compressor Inlet Line. Please refer to WSM procedures in section 412-00.
 - Do not connect to the Thermostatic Expansion Valve Manifold and Tube Assembly at this time.
15. Replace the A/C Condenser. Please refer to WSM procedures in section 412-00.
 - Do not connect to the Thermostatic Expansion Valve at this time.
16. Replace the Thermostatic Expansion Valve Manifold and Tube Assembly. Please refer to WSM procedures in section 412-00.
 - Do not connect the Thermostatic Expansion Valve Manifold and Tube Assembly to the thermostatic expansion valve and rear evaporator rear outlet and inlet lines at this time.
17. Remove the RH front and rear Wheels and Tires. Please refer to WSM procedures in section 204-04A.
18. Remove the RH front Fender splash shield. Please refer to WSM procedures in section 501-02.

Expedition Vehicles Tailpipe and Muffler Removal

19. Loosen the muffler and tailpipe clamp. See Figure 6.
20. Remove the bolts from the isolator. See Figure 6.
21. Release the locator tab releasing the muffler and tailpipe. See Figure 6.

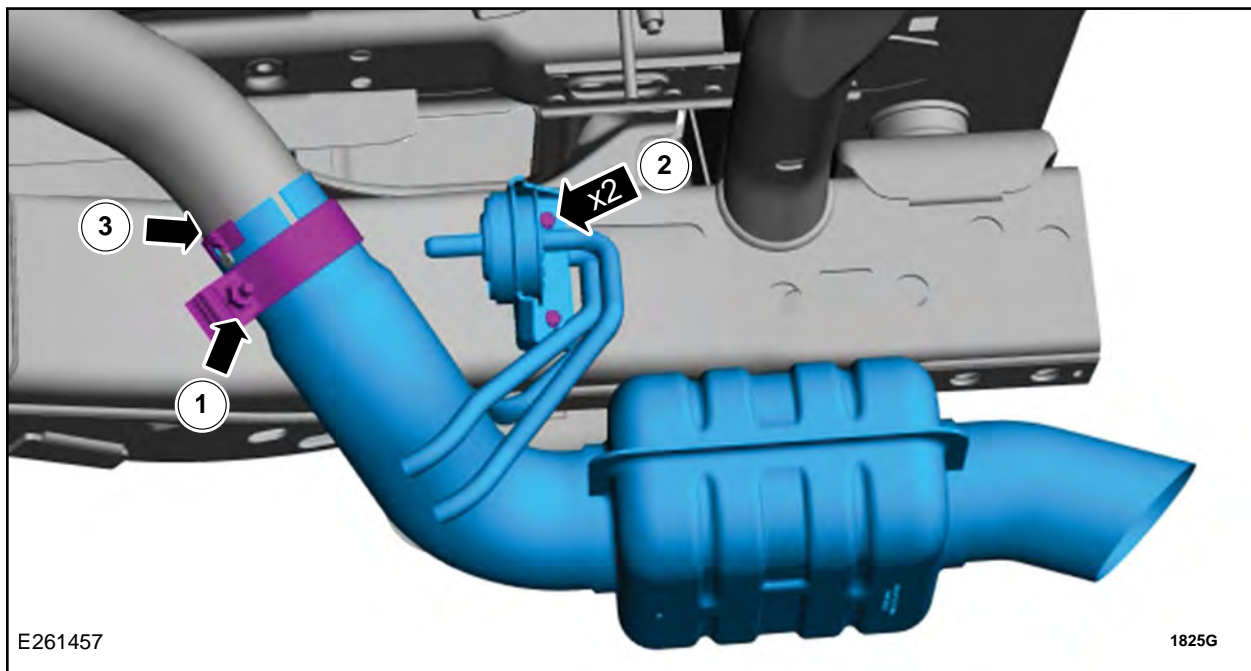

FIGURE 6



22. Remove the catalytic converter and muffler bolts. See Figure 7.

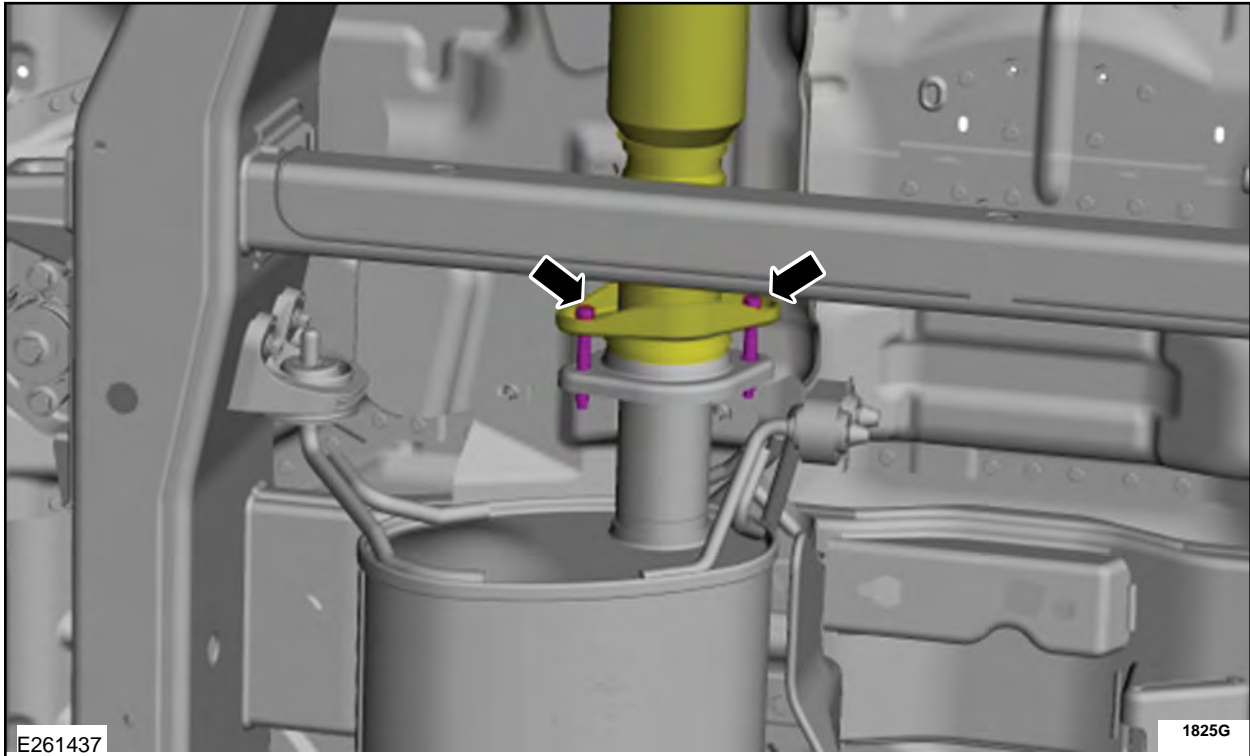

FIGURE 7

23. Remove the isolator bracket bolts and detach the isolators and remove the muffler. See Figure 8.

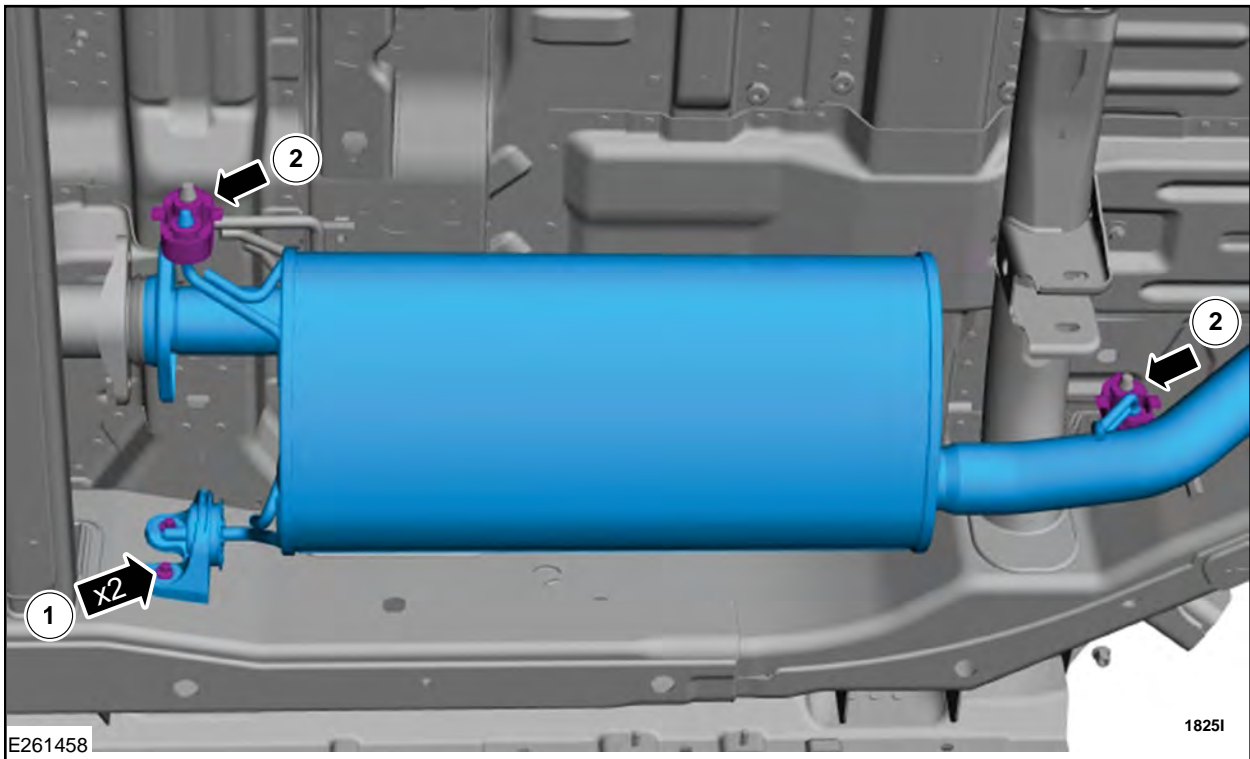

FIGURE 8



Navigator Vehicles Tailpipe and Muffler Removal

24. Loosen the muffler and tailpipe clamps. See Figure 9.

25. Release the locator tabs releasing the muffler and tailpipes. See Figure 9.

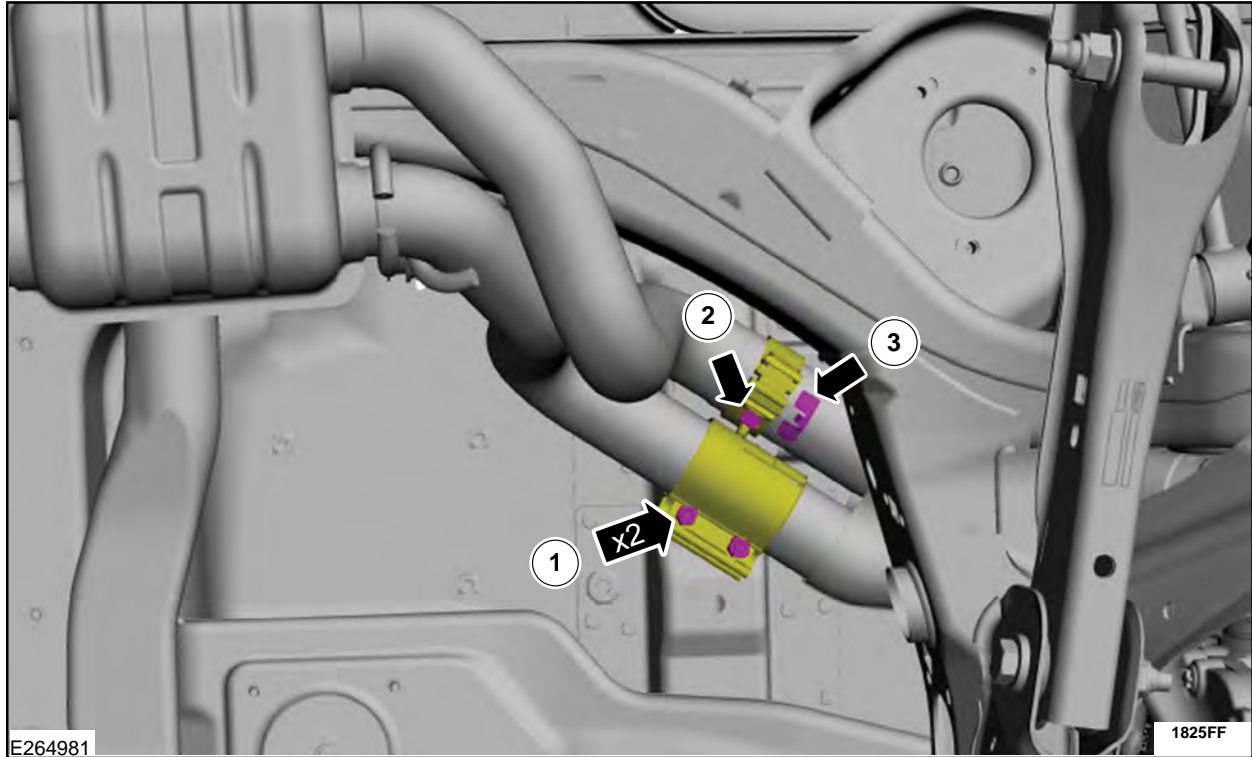

FIGURE 9



26. Remove the bolts and remove the tailpipe. See Figure 10.

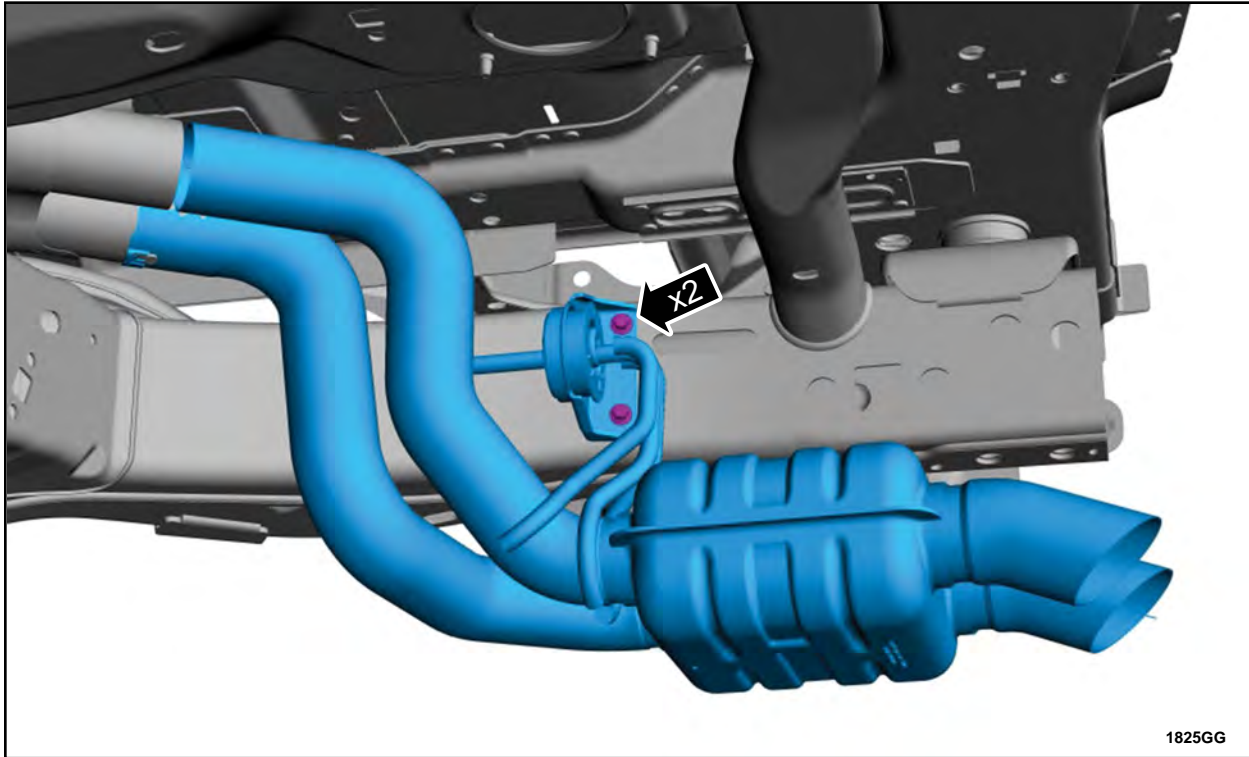

FIGURE 10



27. For Navigator vehicles loosen the clamps, release the tabs and slide the clamps back on the muffler.
See Figure 11.

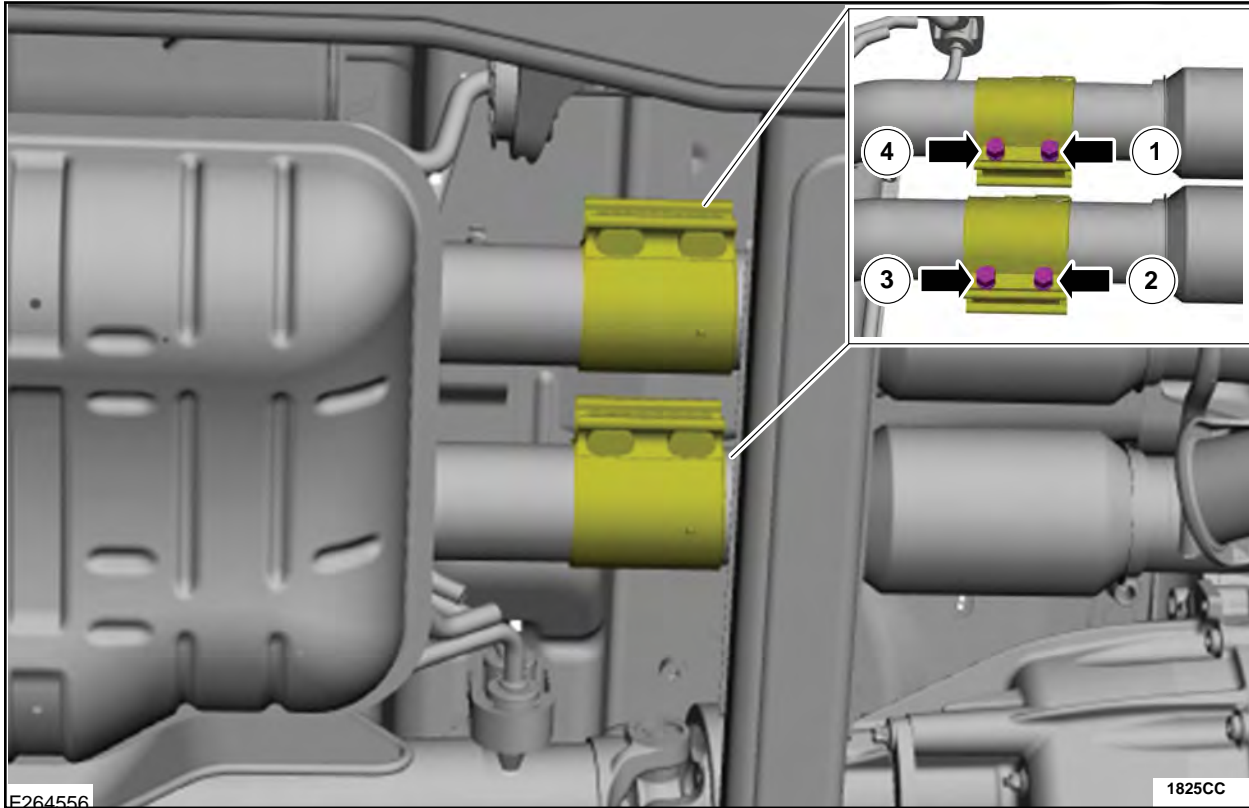

FIGURE 11



28. Detach the isolators and remove the muffler. See Figure 12.

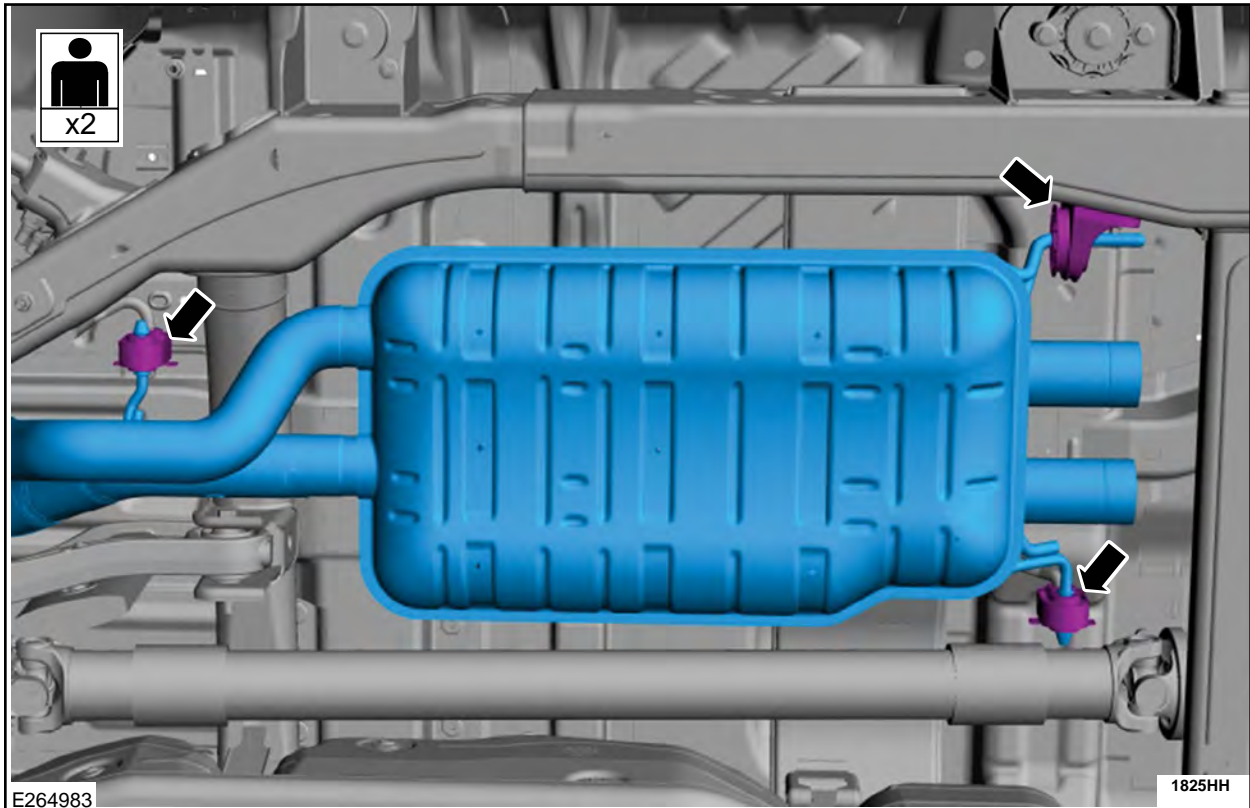

FIGURE 12

LH Catalytic Converter Removal All Vehicles

29. Disconnect the HO2S electrical connector. See Figure 13.

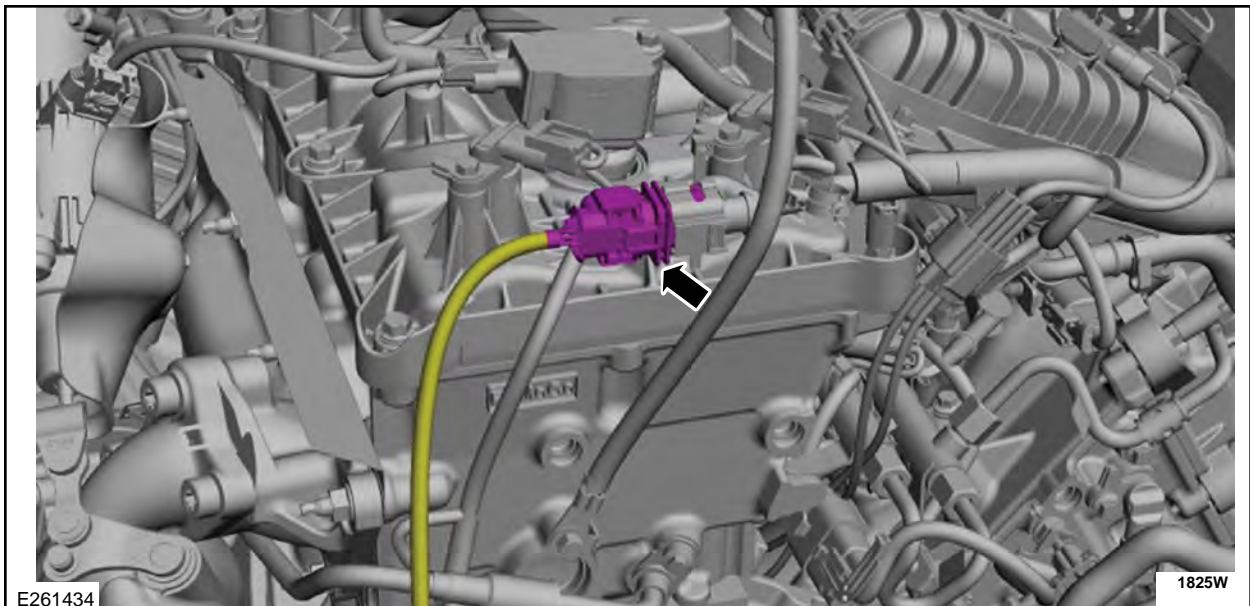

FIGURE 13



30. If equipped remove the retainers and remove the transmission housing cover. See Figure 14.

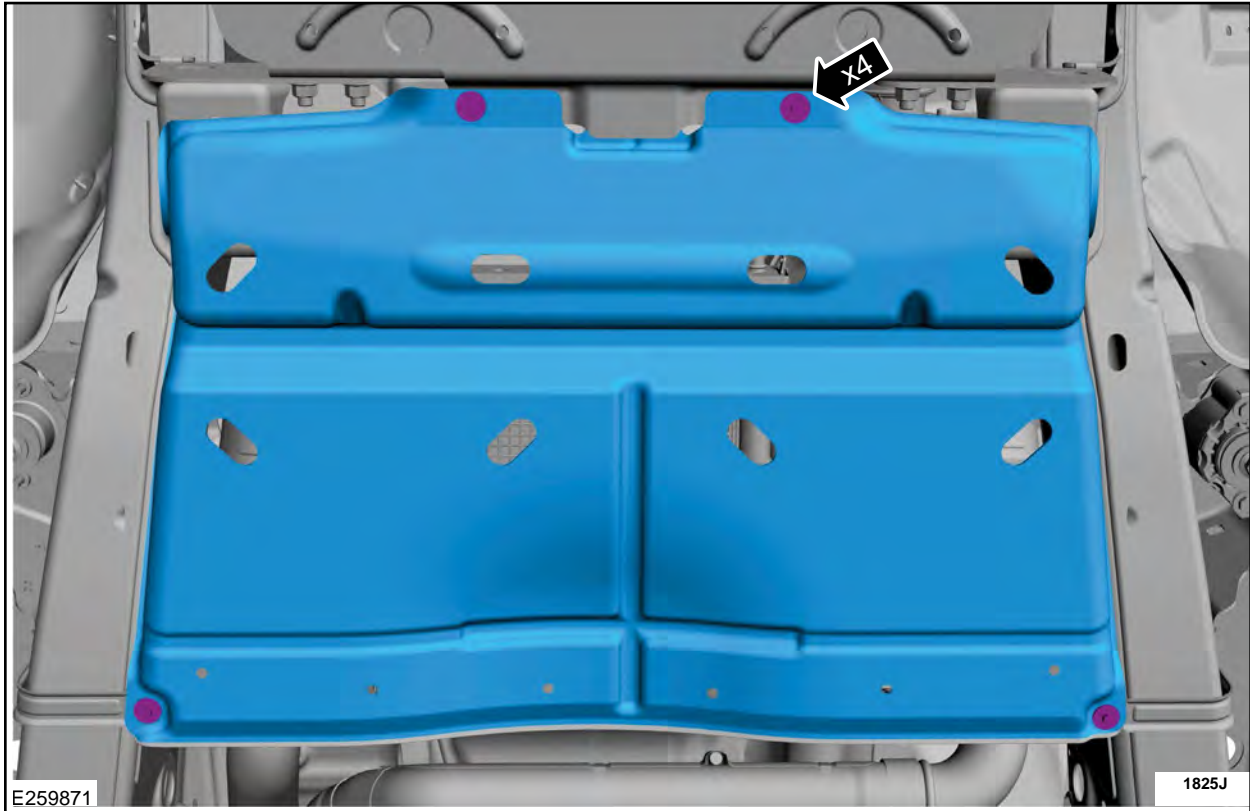

FIGURE 14

31. Disconnect the HO2S electrical connector. See Figure 15.

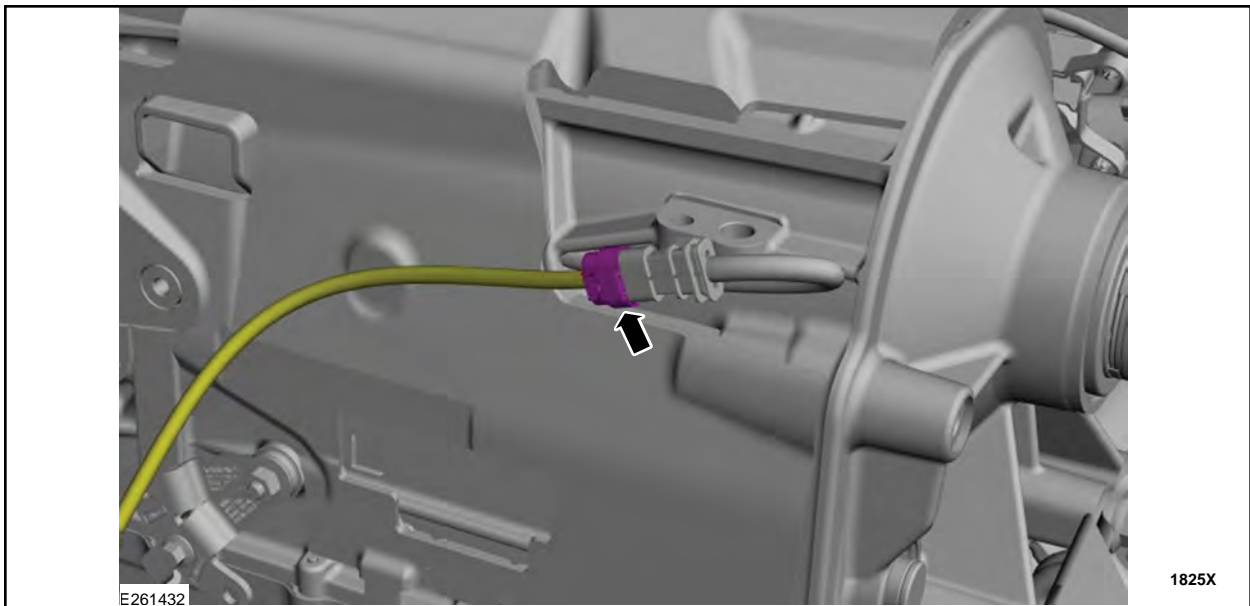

FIGURE 15



32. Remove the LH catalytic converter nuts and discard. See Figure 16.

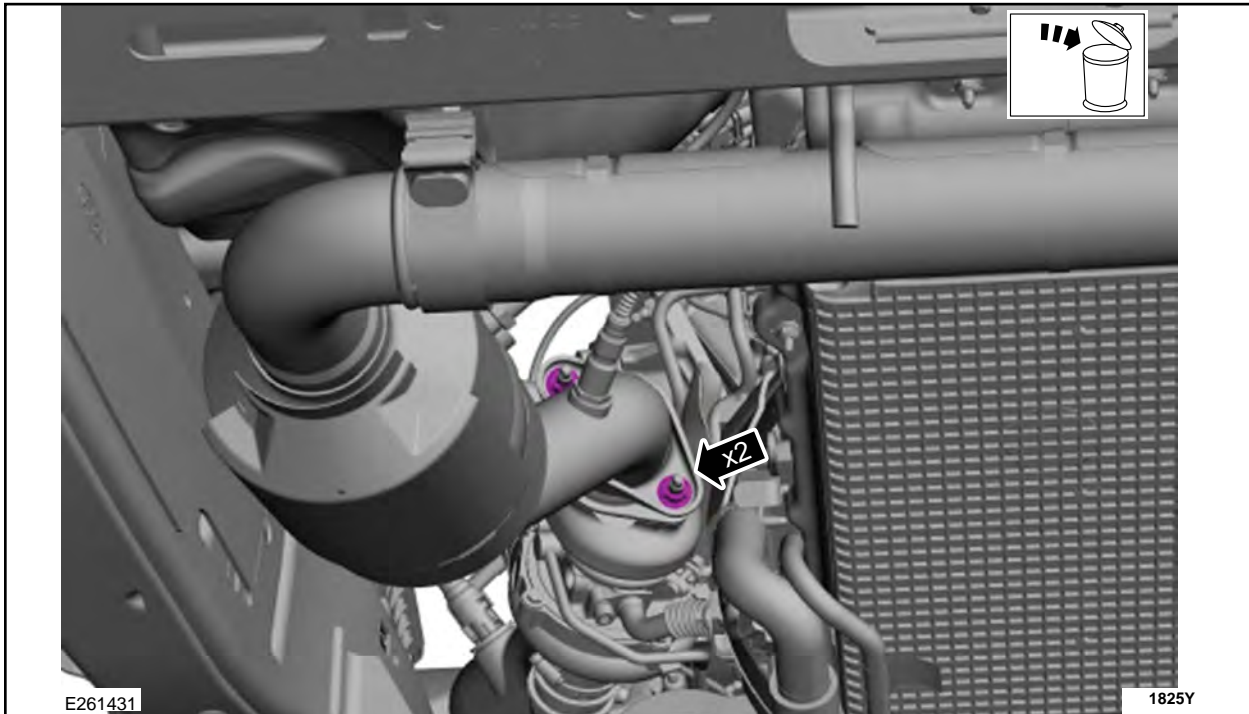

FIGURE 16

33. Loosen the clamp and remove the LH catalytic converter. See Figure 17.

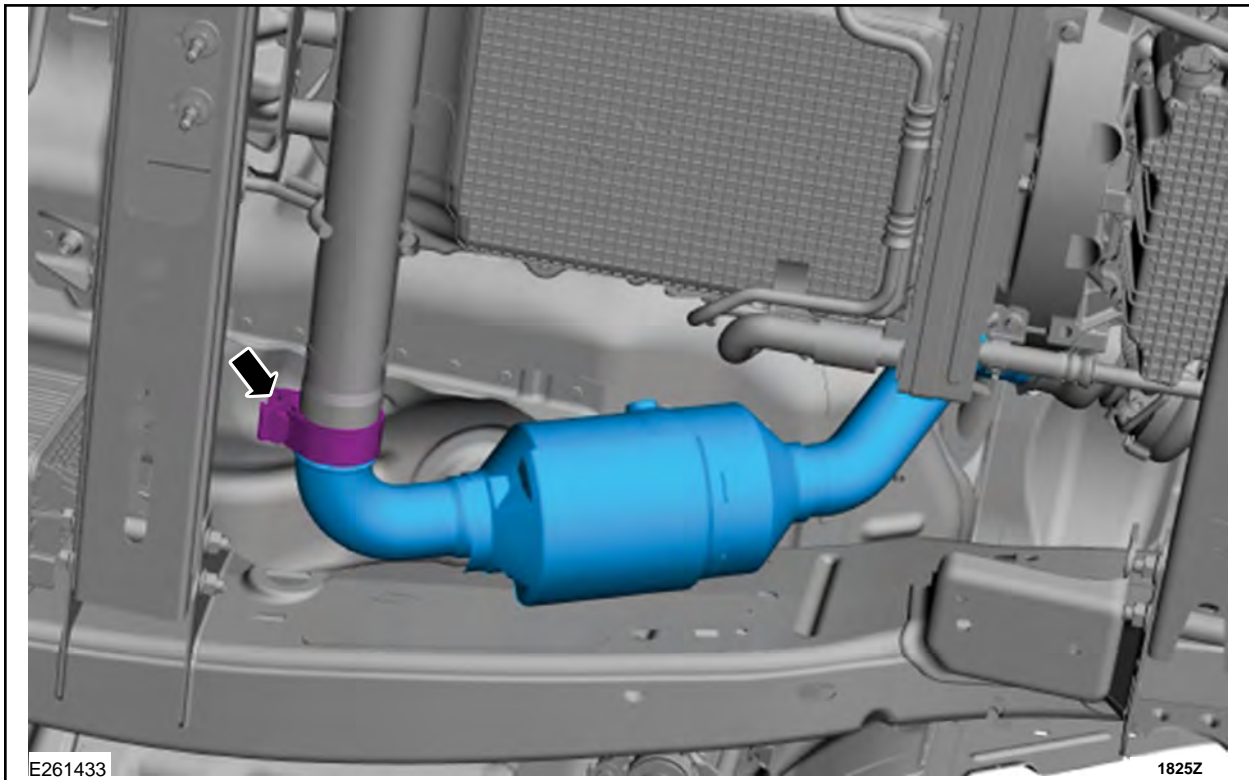

FIGURE 17



Transmission Crossmember and Support Insulator Removal All Vehicles

34. If equipped remove the skid plate bolts and remove the skid plate. See Figure 18.

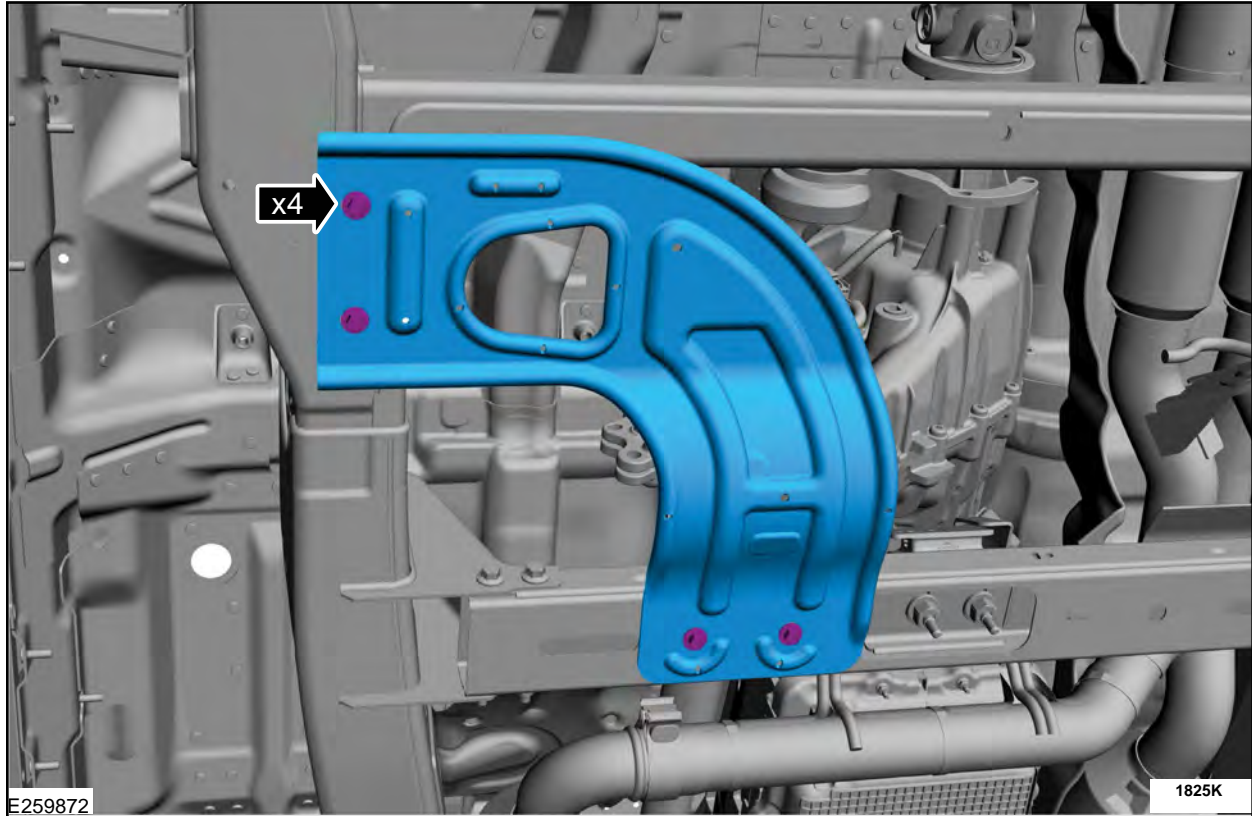

FIGURE 18



35. Remove the LH exhaust heat shield bolt from the transmission crossmember. See Figure 19.



FIGURE 19



36. Remove the RH outboard exhaust heat shield retainers and heat shield. See Figure 20.

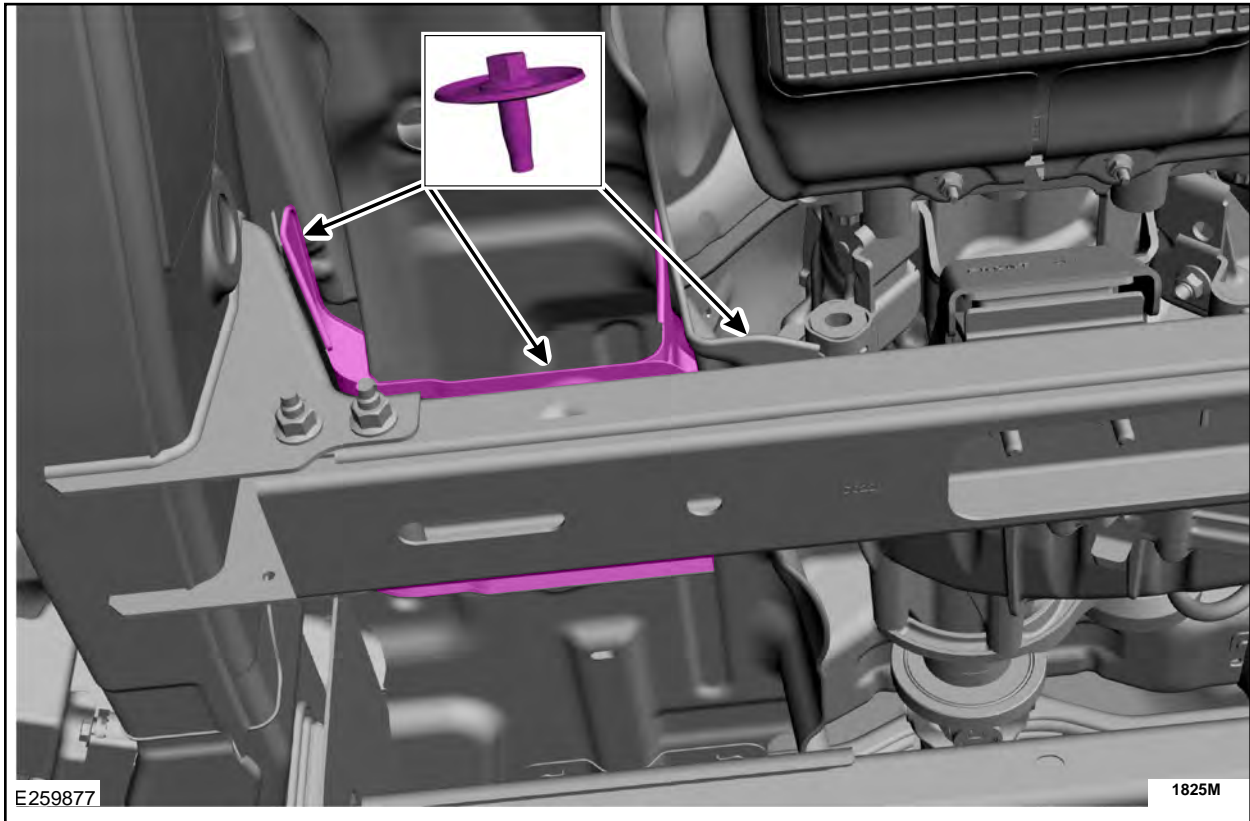

FIGURE 20



37. Using a high lift transmission jack support the transmission, be sure the jack makes contact with the outer ribs of the transmission fluid pan.
38. Remove the two transmission wiring harness bolts from the crossmember and position the wiring harness aside. See Figure 21.

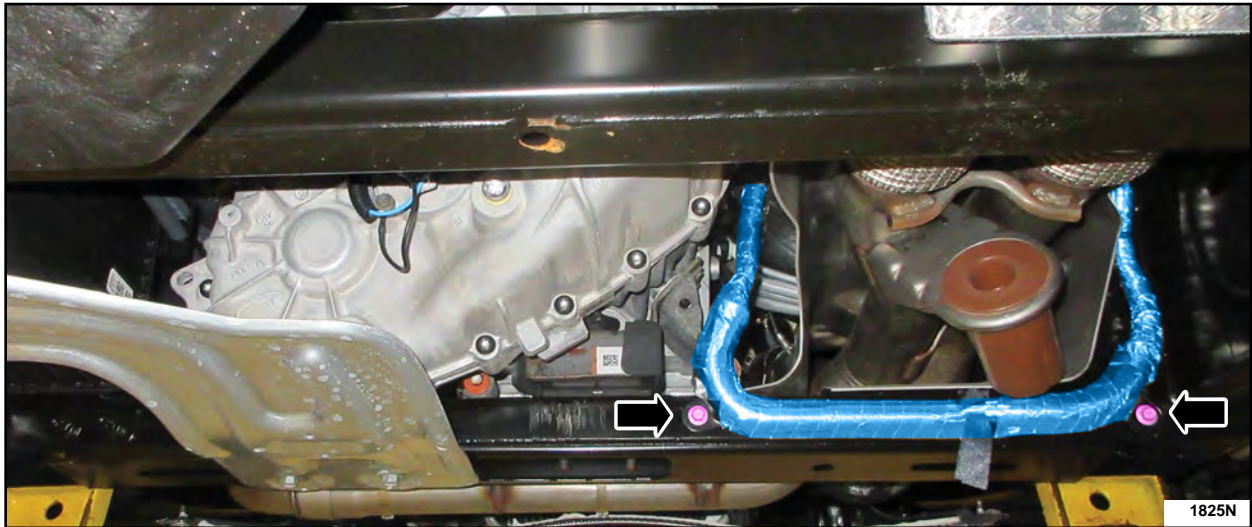

FIGURE 21

39. Remove and discard the transmission support crossmember nuts and bolts. See Figure 22.

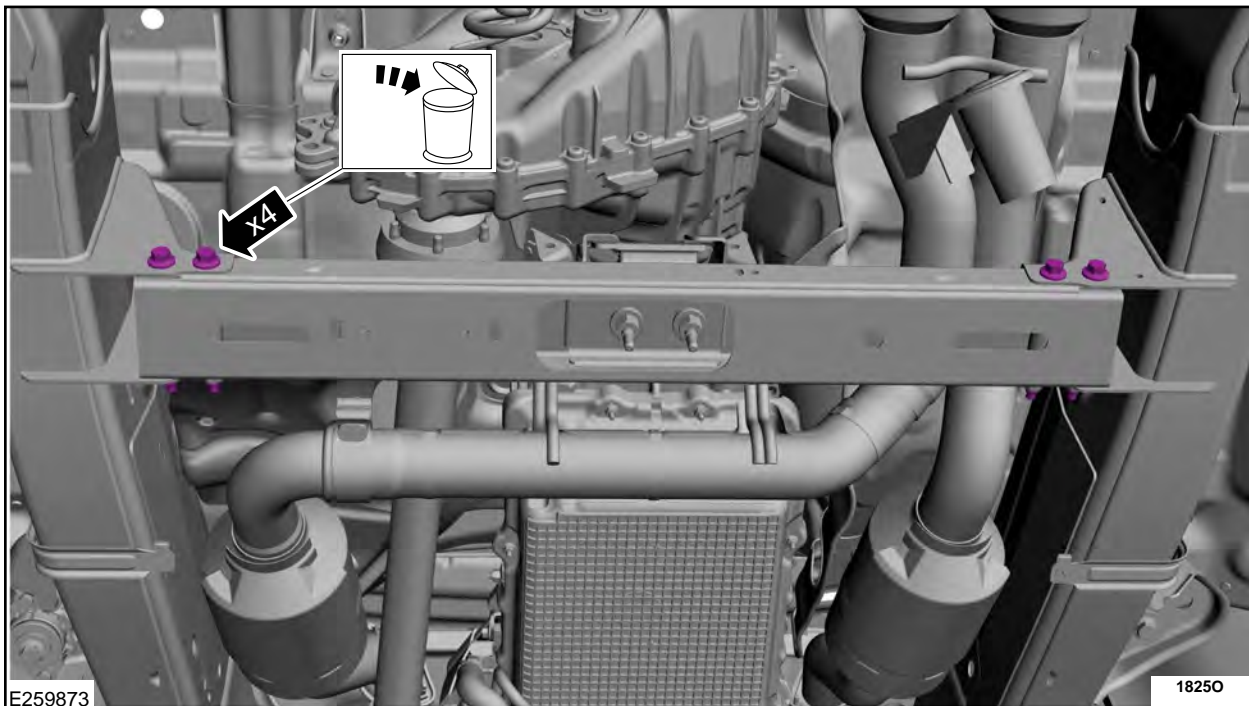

FIGURE 22



40. Remove the transmission mount nuts and the transmission support crossmember. See Figure 23.

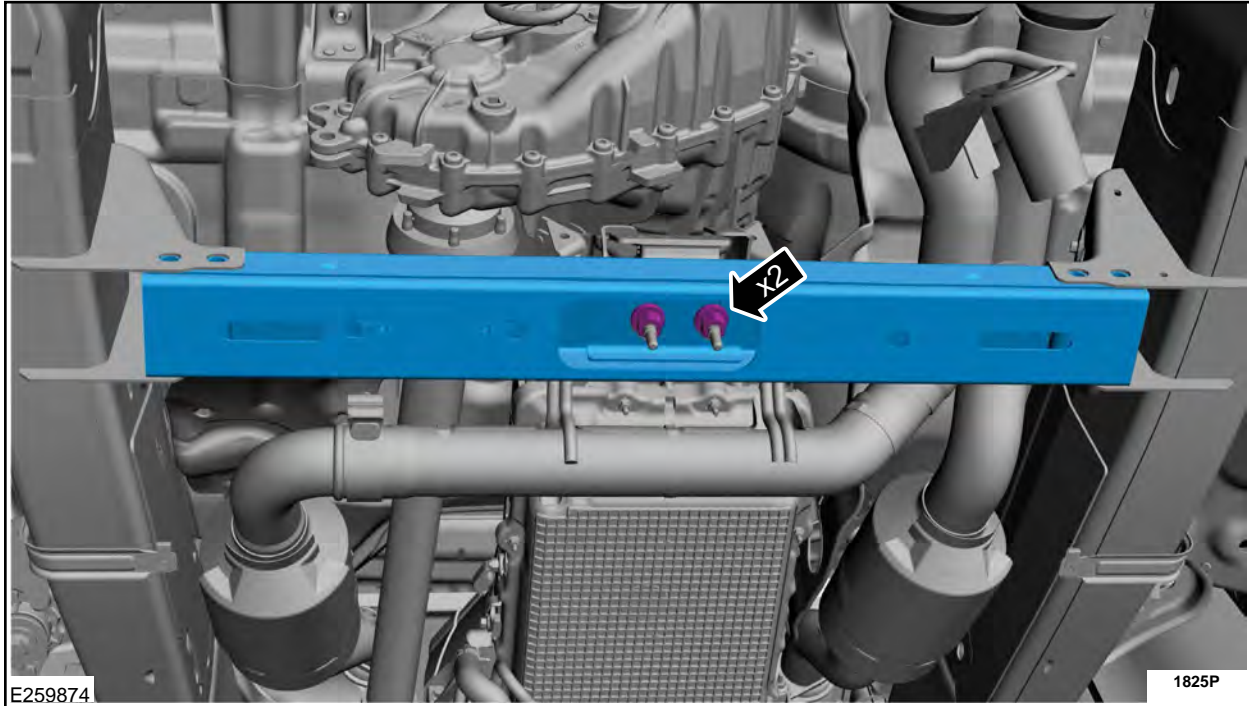

FIGURE 23



Rear Wheel Drive (RWD) Vehicles

41. Remove the bolt and the LH isolator cap. See Figure 24.

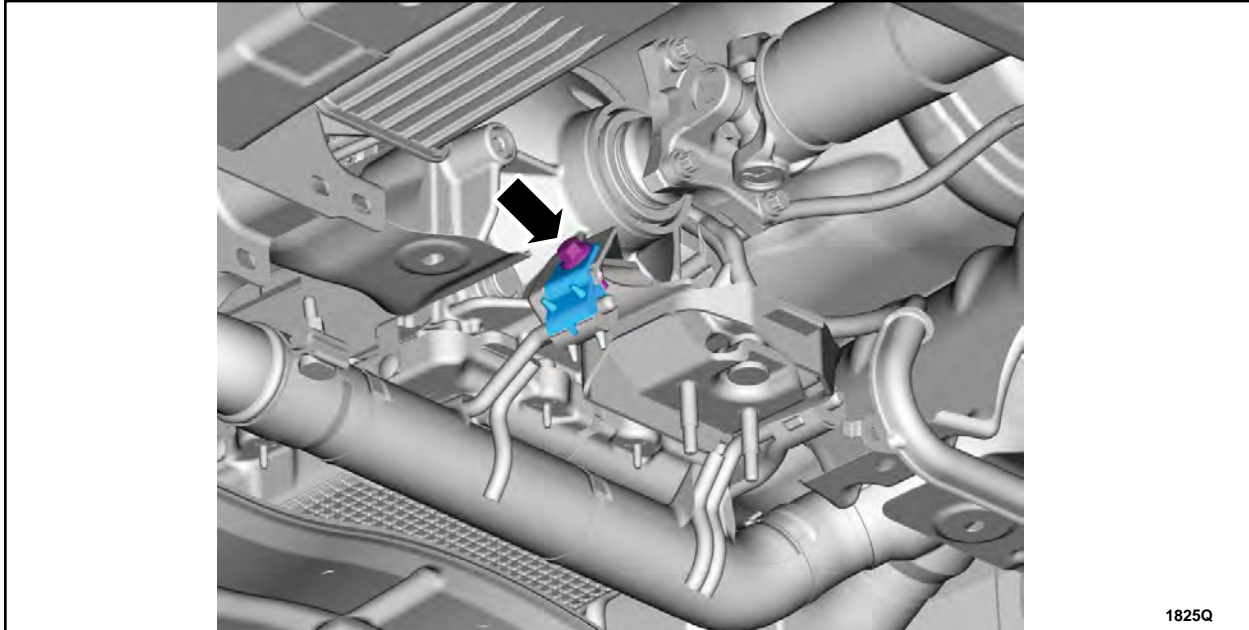

FIGURE 24

42. Remove and discard the transmission support insulator bolts and washers. See Figure 25.

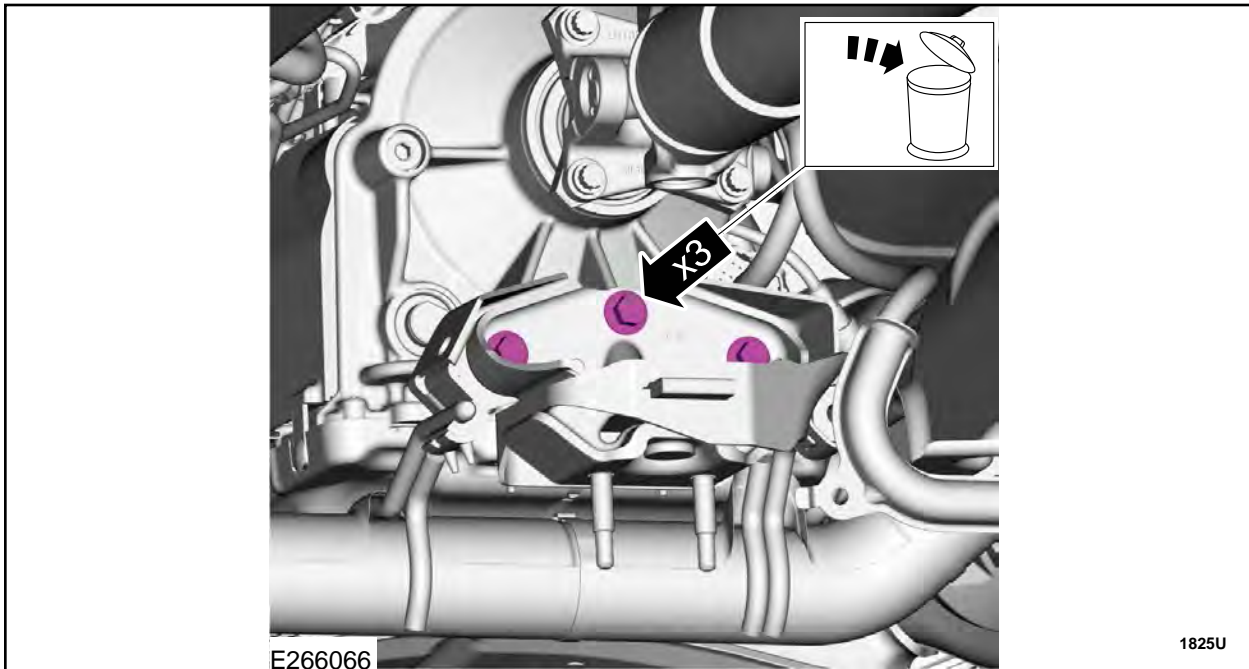

FIGURE 25



43. Remove the transmission support insulator. See Figure 26.

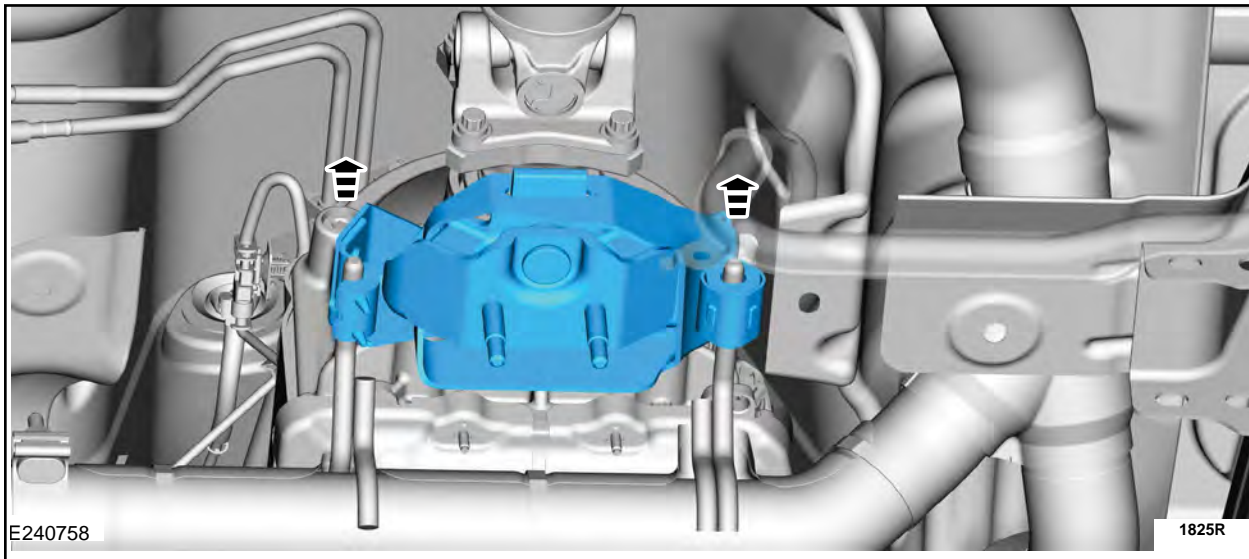

FIGURE 26

Four-Wheel Drive (4WD) Vehicles

44. Remove the bolt and the LH isolator cap. See Figure 27.

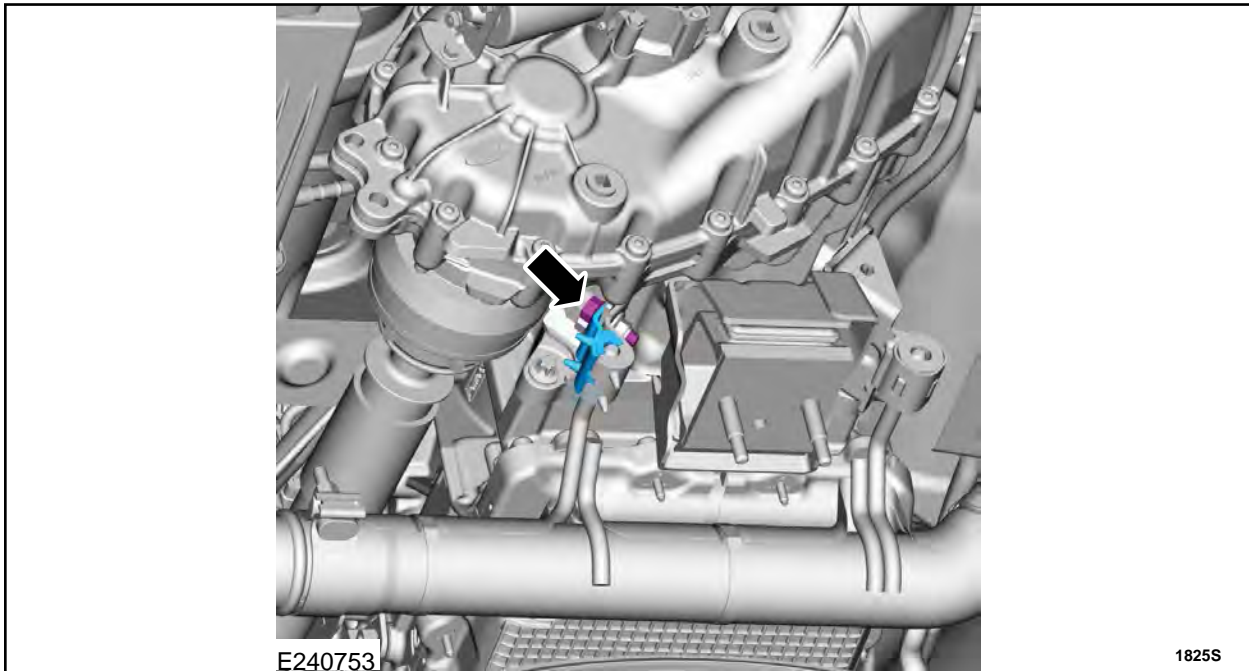

FIGURE 27



45. Remove and discard the transmission support insulator bolts and washers. See Figure 28.

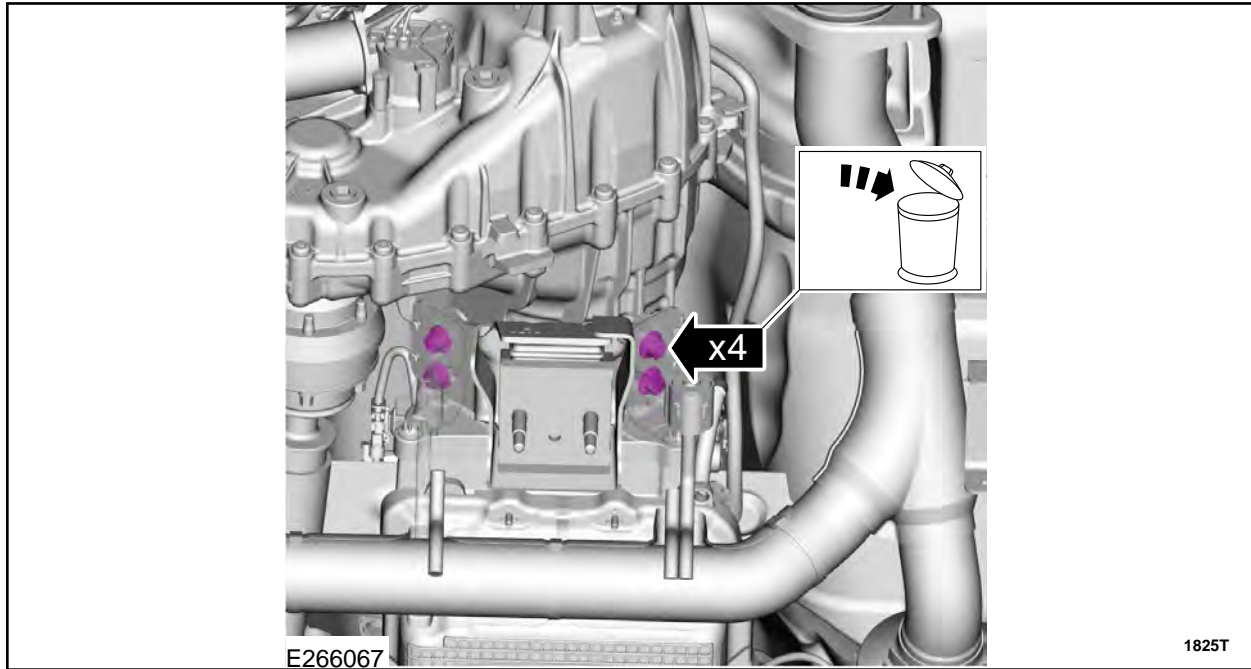

FIGURE 28

46. Remove the transmission support insulator. See Figure 29.

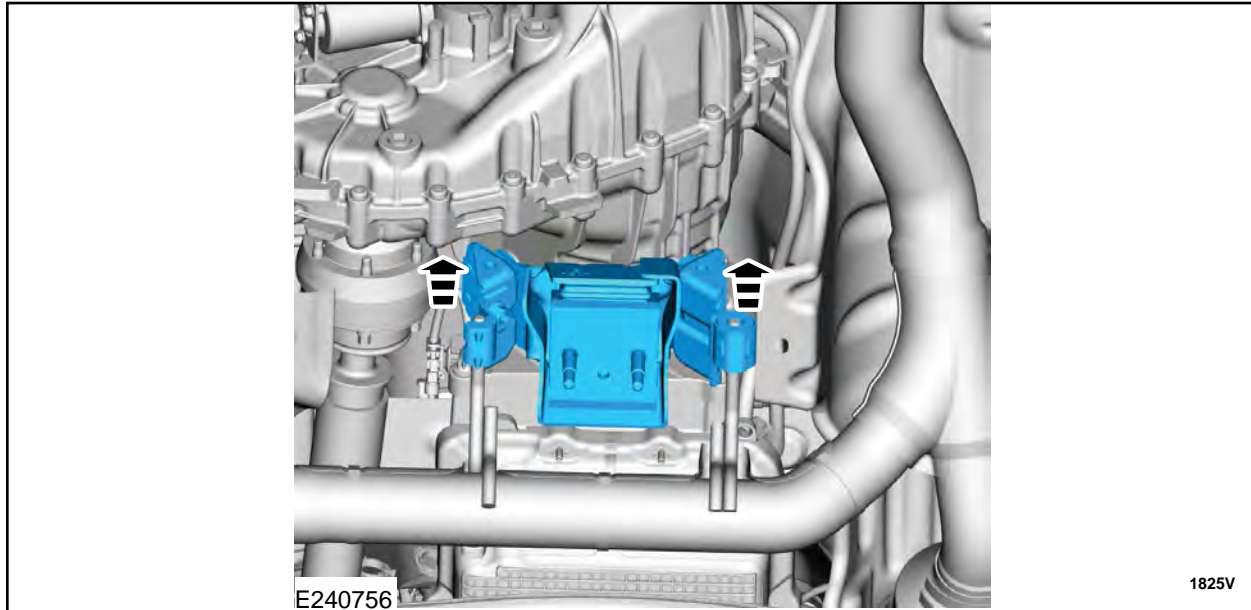

FIGURE 29



RH Catalytic Converter Removal All Vehicles

47. Disconnect the HO2S electrical connector. See Figure 30.

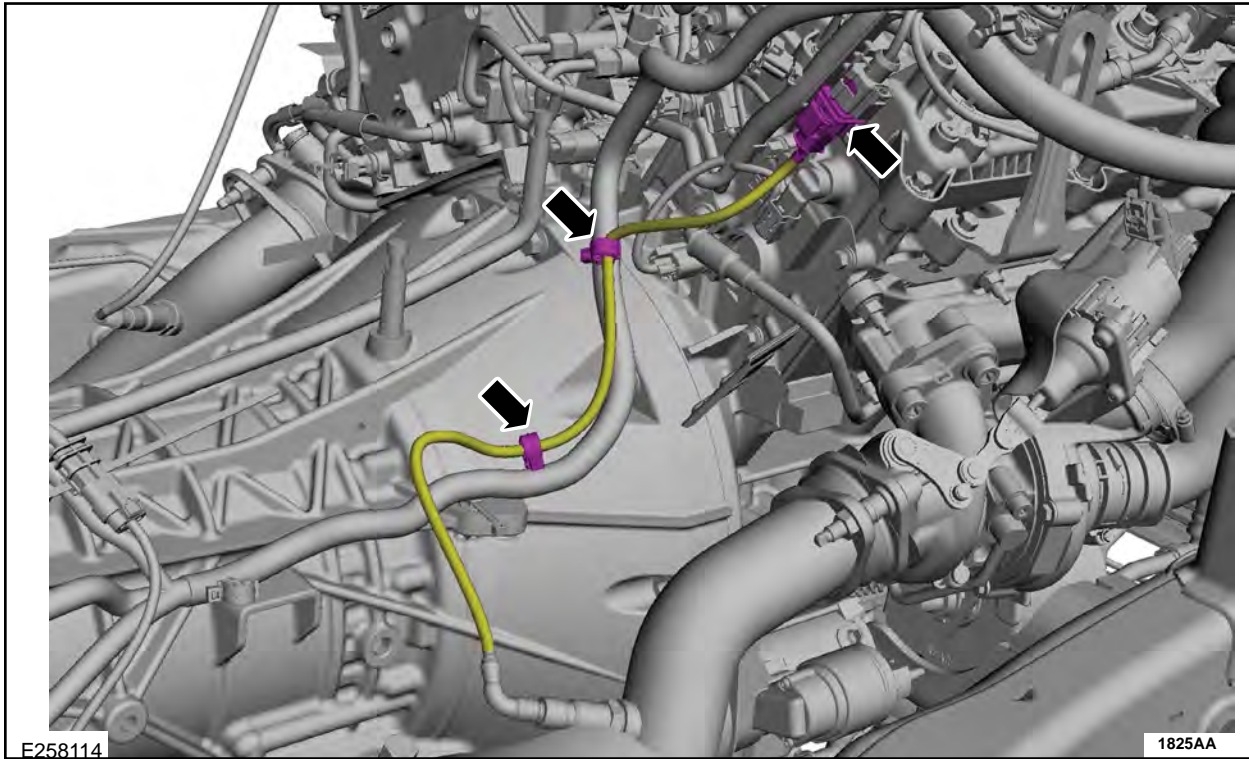

FIGURE 30

48. Disconnect the HO2S electrical connector. See Figure 31.

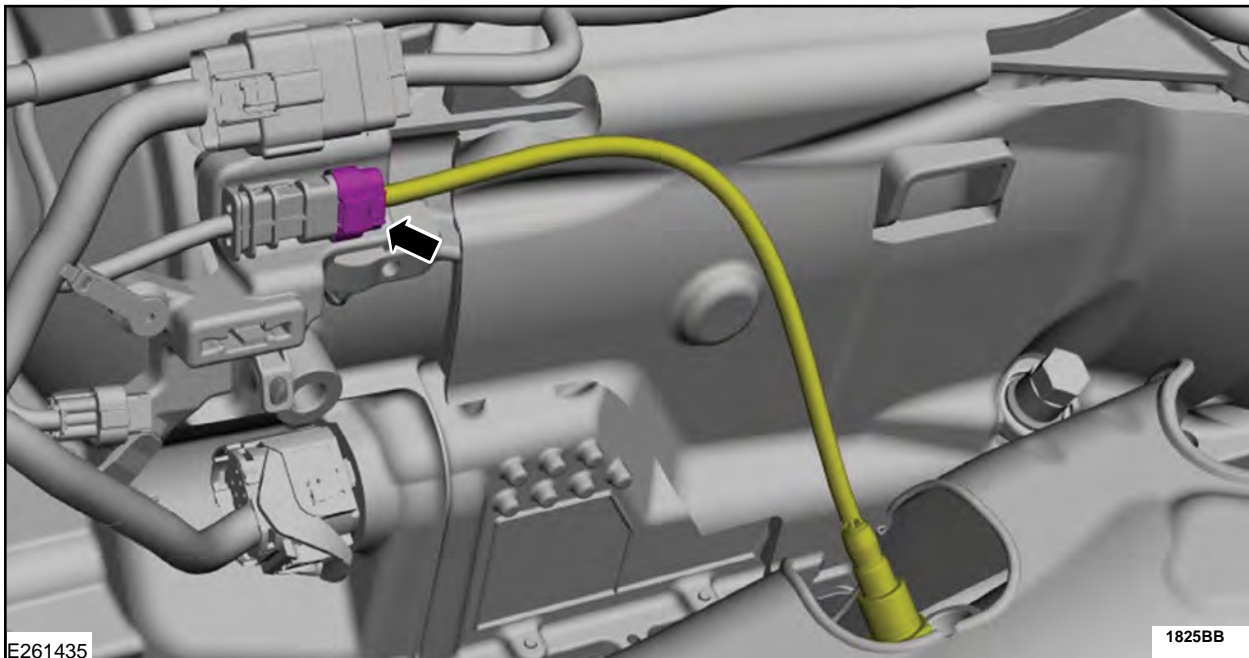

FIGURE 31



49. Remove the RH catalytic converter nuts and discard. Remove the RH catalytic converter.
See Figure 32.

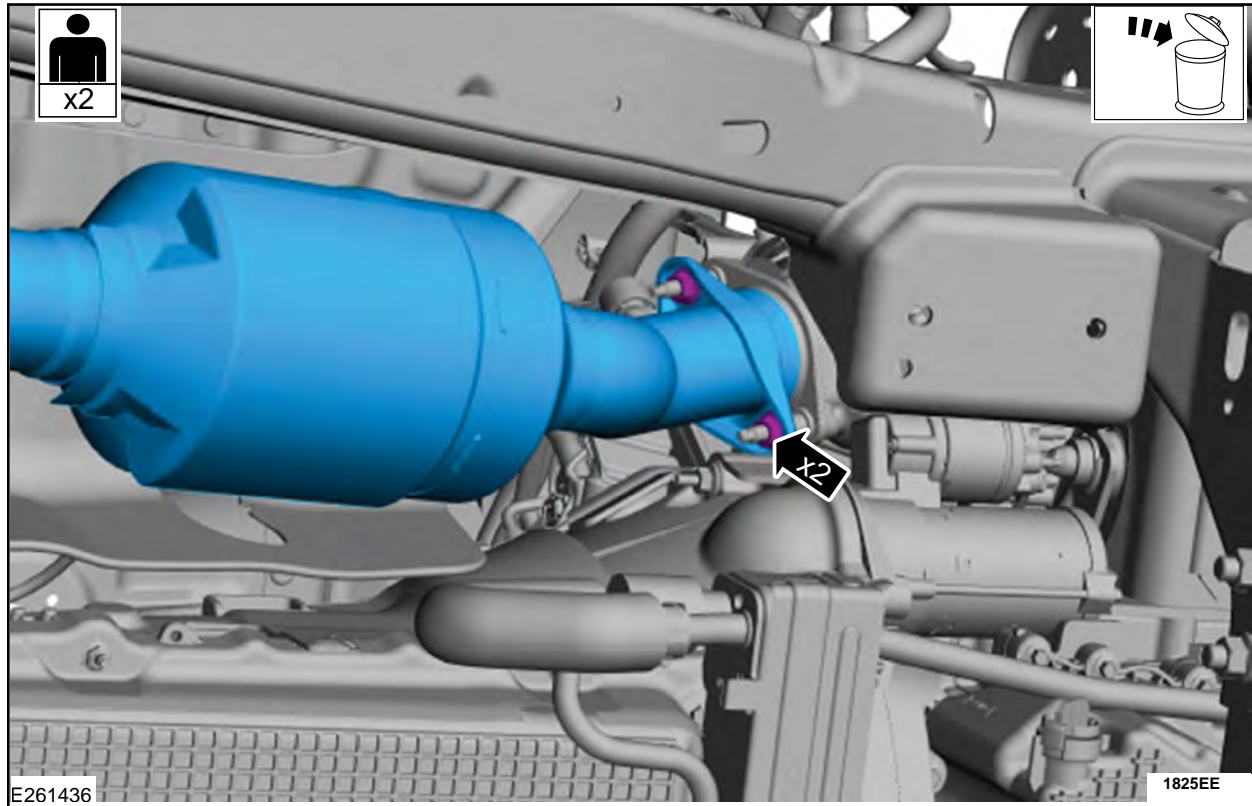

FIGURE 32

Rear A/C

50. Replace the Rear Evaporator Rear Outlet and Inlet Lines. Please refer to WSM procedures in section 412-02.

NOTE: Be sure to only cut and remove the A/C lines not the heater core lines.

IMPORTANT! Do not connect the underbody lines to the rear climate control housing, doing so could contaminant the new components.



RH Catalytic Converter Installation All Vehicles

51. Install the RH catalytic converter and nuts. See Figure 32.

- Torque to 30 lb.ft (40 Nm).

52. Connect both RH HO2S electrical connectors. See Figures 30 and 31.

Transmission Insulator Installation Rear Wheel Drive (RWD) Vehicles

53. Install the transmission support insulator. See Figure 33.

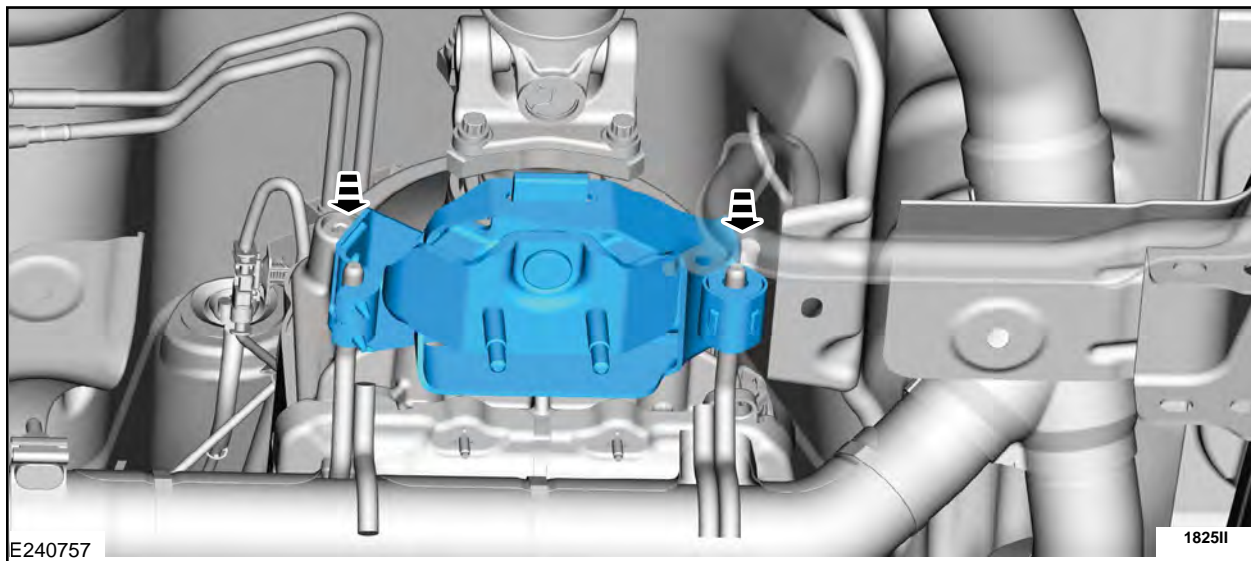

FIGURE 33



54. Install the transmission support insulator bolts in the sequence shown. See Figure 34.

- Torque to 66 lb.ft (90 Nm).

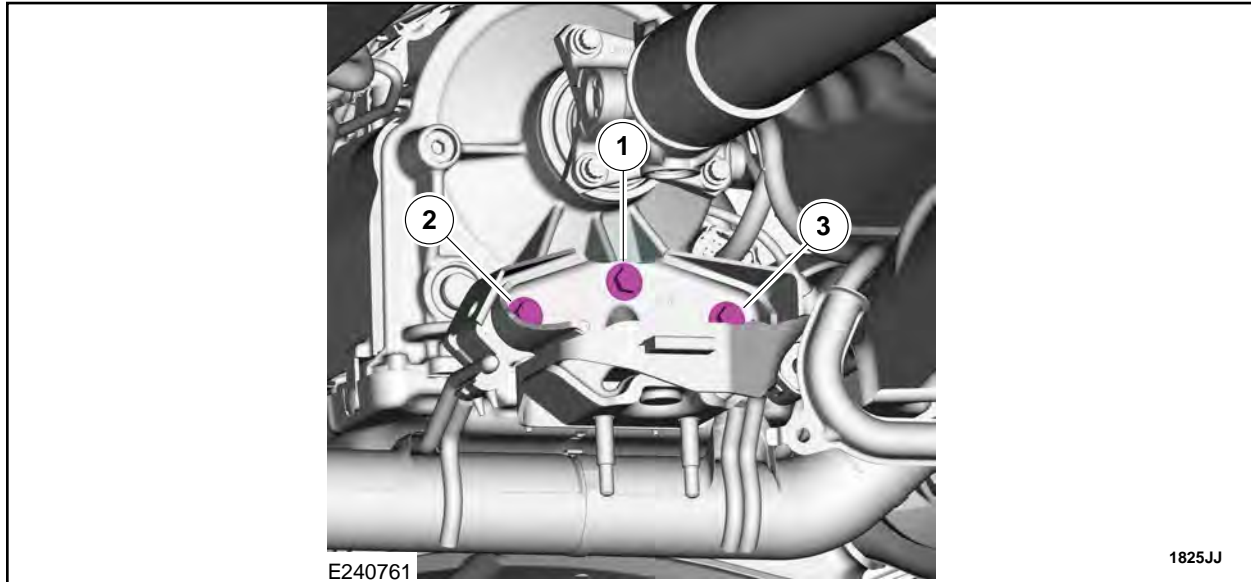

FIGURE 34

55. Install the LH isolator cap and the bolt. See Figure 35.

- Torque to 41 lb.ft (55 Nm).

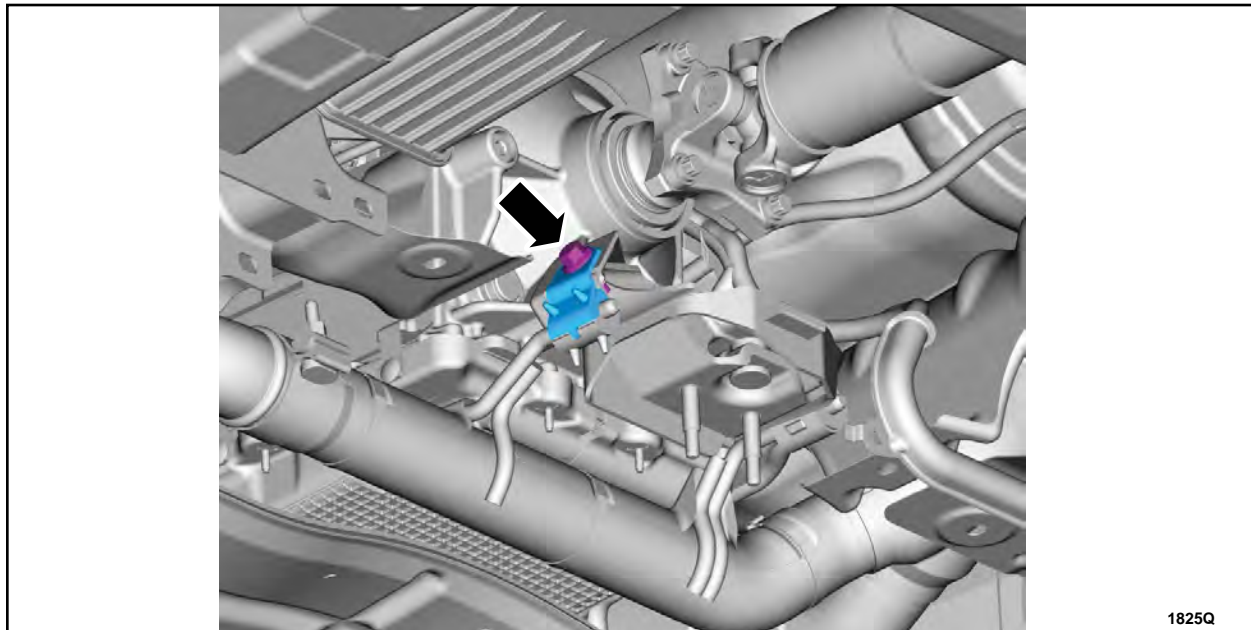

FIGURE 35



Transmission Insulator Installation Four Wheel Drive (4WD) Vehicles

56. Install the transmission support insulator. See Figure 36.

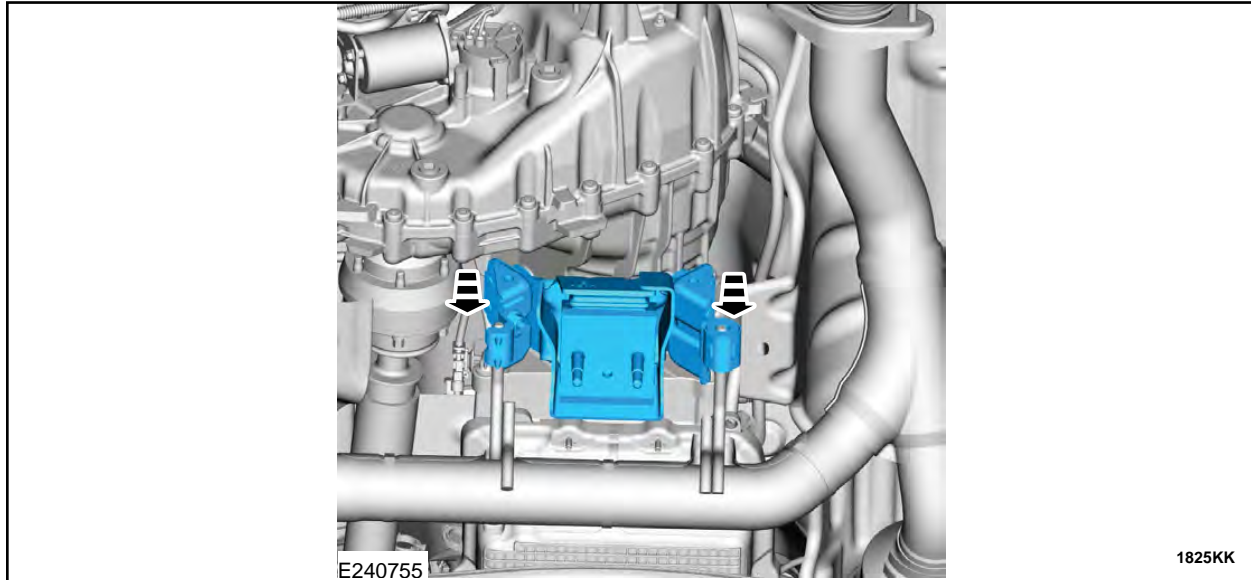

FIGURE 36

57. Install the transmission support insulator bolts in the sequence shown. See Figure 37.

- Torque to 76 lb.ft (103 Nm).

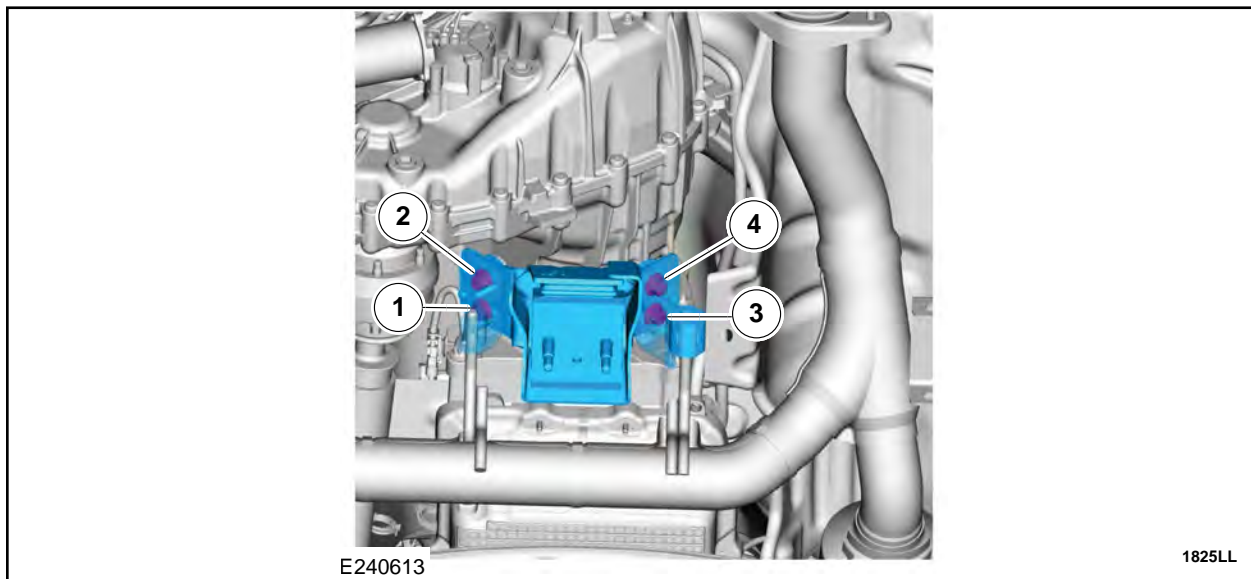

FIGURE 37



58. Install the LH isolator cap and the bolt. See Figure 38.

- Torque to 41 lb.ft (55 Nm).

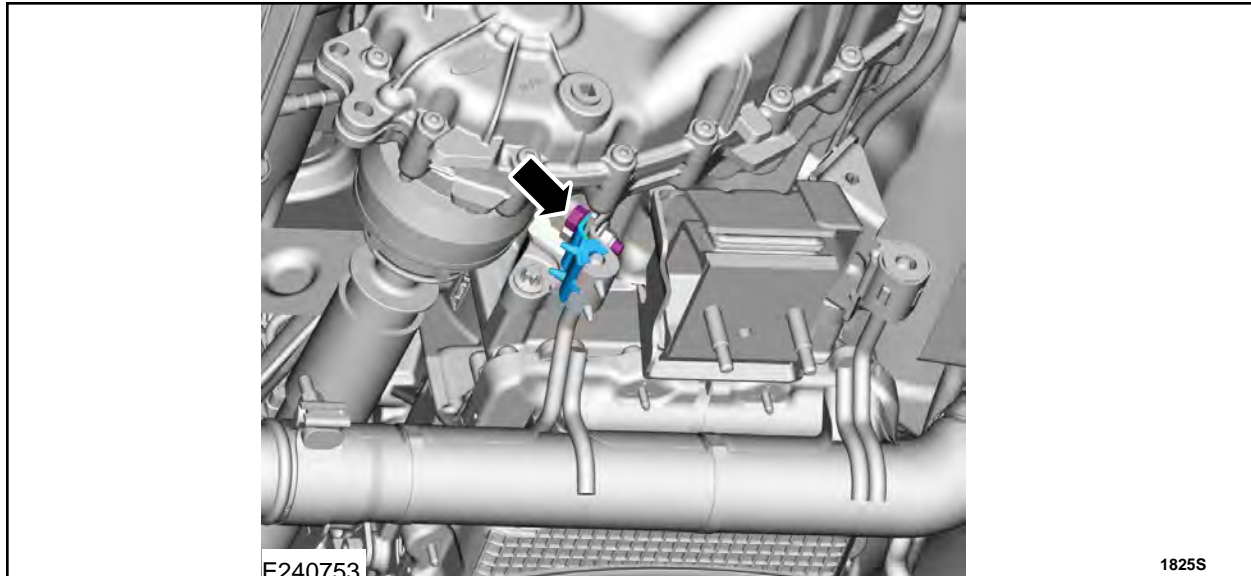

FIGURE 38

Transmission Support Crossmember Installation All Vehicles

59. Install the transmission support crossmember and the transmission mount nuts. See Figure 39.

- Torque to 85 lb.ft (115 Nm).

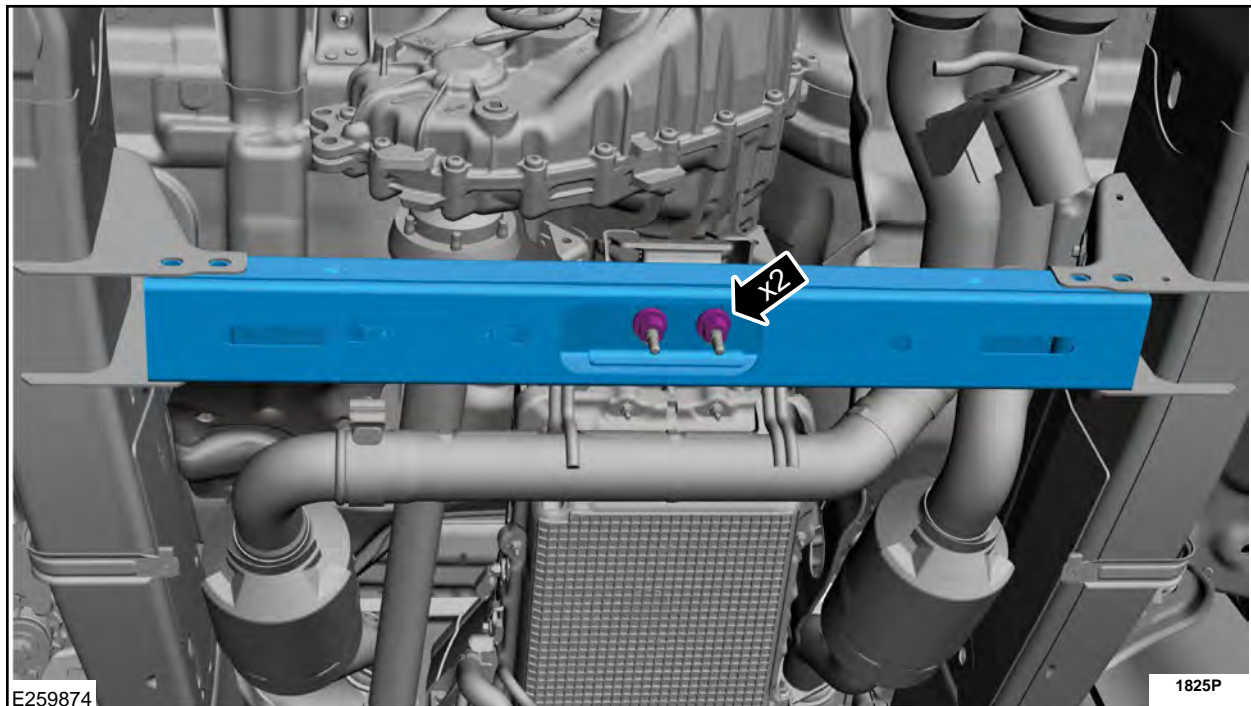

FIGURE 39



60. Install the transmission support crossmember nuts and bolts. See Figure 40.

- Torque to 76 lb.ft (103 Nm).

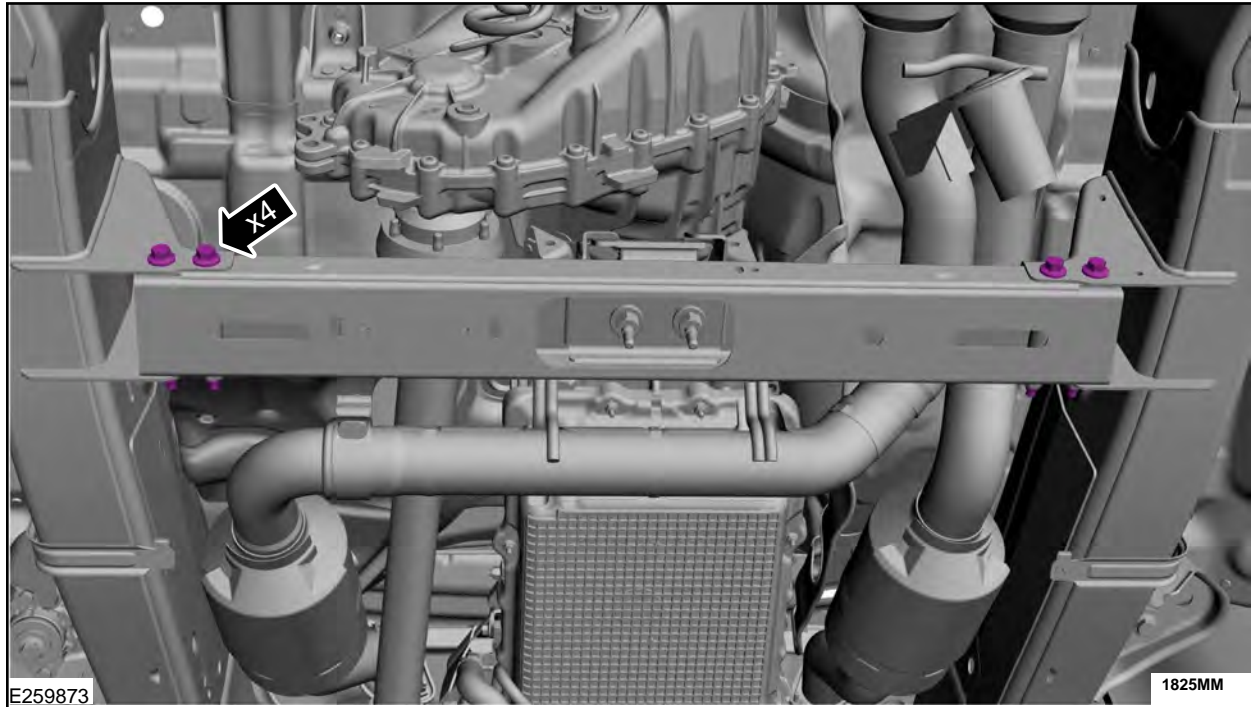

FIGURE 40

61. Remove the high lift transmission jack support from the transmission.

62. Install the two transmission wiring harness bolts into the transmission crossmember. See Figure 21.

63. Install the RH outboard exhaust heat shield and retainers. See Figure 20.

- Torque to 177 lb.in (20 Nm).

64. Install the LH exhaust heat shield bolt from the transmission crossmember. See Figure 19.

- Torque to 177 lb.in (20 Nm).

65. If equipped install skid plat and retainers. See Figure 18.

- Torque to 177 lb.in (20 Nm).



LH Catalytic Converter Installation All Vehicles

66. Install the LH catalytic converter in vehicle. Install the LH catalytic converter nuts. See Figure 16.

- Torque to 30 lb.ft (40 Nm).

67. Tighten the clamp. See Figure 41.

- Torque to 41 lb.ft (55 Nm).

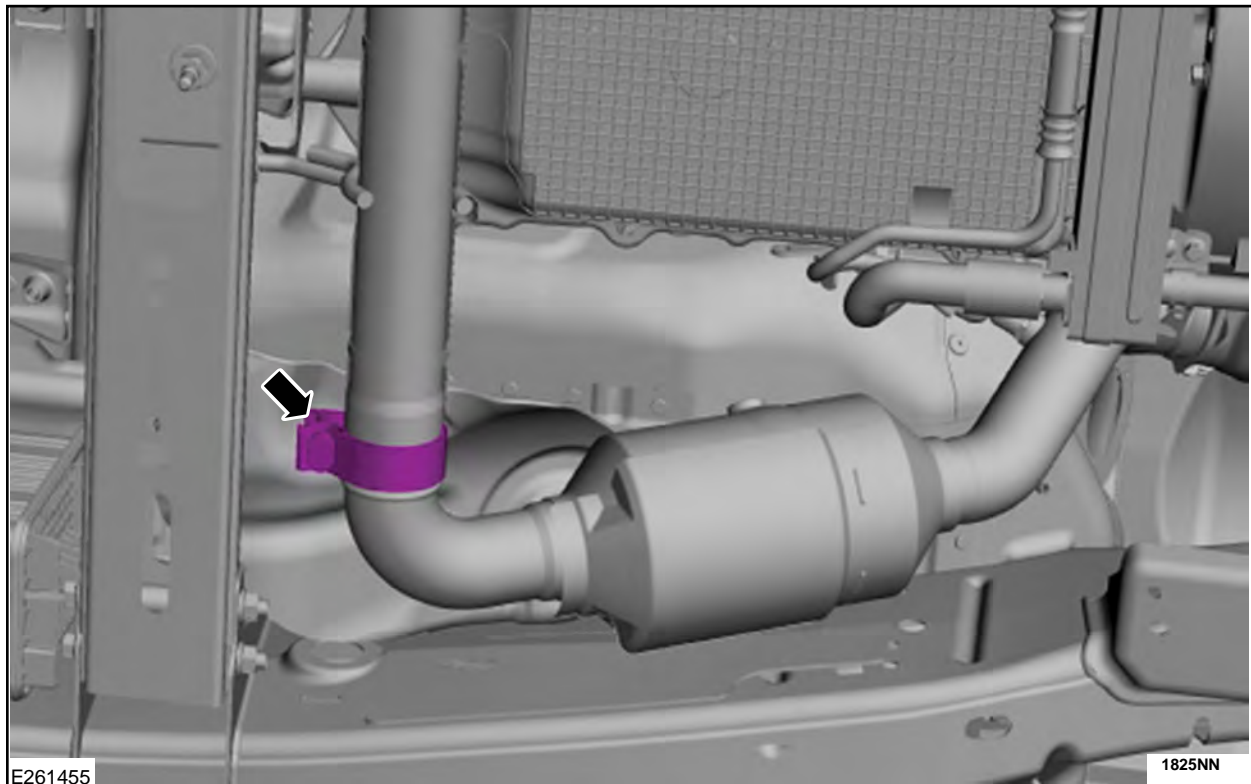

FIGURE 41

68. Connect both LH HO₂S electrical connectors. See Figures 13 and 15.

69. If equipped install the underbody shield and bolts. See Figure 14.

- Torque to 71 lb.in (8 Nm).



Muffler and Tailpipe Installation Expedition Vehicles

70. Install the muffler and attach the isolators and bracket bolts. See Figure 8.

- Torque to 18 lb.ft (25 Nm).

71. Install the catalytic converter and muffler bolts. See Figure 7.

- Torque to 46 lb.ft (63 Nm).

72. Install the muffler and tailpipe. See Figure 6.

73. Install the isolator bolts. See Figure 6.

- Torque to 18 lb.ft (25 Nm).

74. Install into position the muffler and tailpipe clamp. See Figure 6.

- Torque to 41 lb.ft (55 Nm).

Muffler and Tailpipe Installation Navigator Vehicles

75. Install the muffler and attach to the isolators. See Figure 12.

76. Install the clamps into position and tighten in the sequence shown. See Figure 11.

- Torque to 35 lb.ft (48 Nm).

77. Install the muffler and tailpipe. See Figure 10.

78. Install the muffler and tailpipe clamps. See Figure 9.

- 1 Torque to 35 lb.ft (48 Nm).
- 2 Torque to 41 lb.ft (55 Nm).

Rear Climate Control Housing All Vehicles

79. Remove and discard the Rear Climate Control Housing. Please refer to WSM procedures in section 412-02.

NOTE: Only remove the third row single seat to access the rear climate control housing.

80. Install the new Rear Climate Control Housing. Please refer to WSM procedures in section 412-02.

NOTE: Connect the Rear Evaporator Rear Outlet and Inlet Lines to the rear climate control housing.



81. Install the RH front Fender splash shield. Please refer to WSM procedures in section 501-02

82. Install the RH front and rear wheels and tires. Please refer to WSM procedures in section 204-04A.

Front Climate Control Housing All Vehicles

83. Replace the front climate control housing and install the new thermostatic expansion valve while the climate control housing is out of the vehicle. Please refer to WSM procedures in section 412-00.

Underhood Component Connection

84. Install and connect the Thermostatic Expansion Valve Manifold and Tube Assembly to the front climate control housing Thermostatic Expansion Valve. See Figure 42.

- Torque to 133 lb.in (15 Nm).

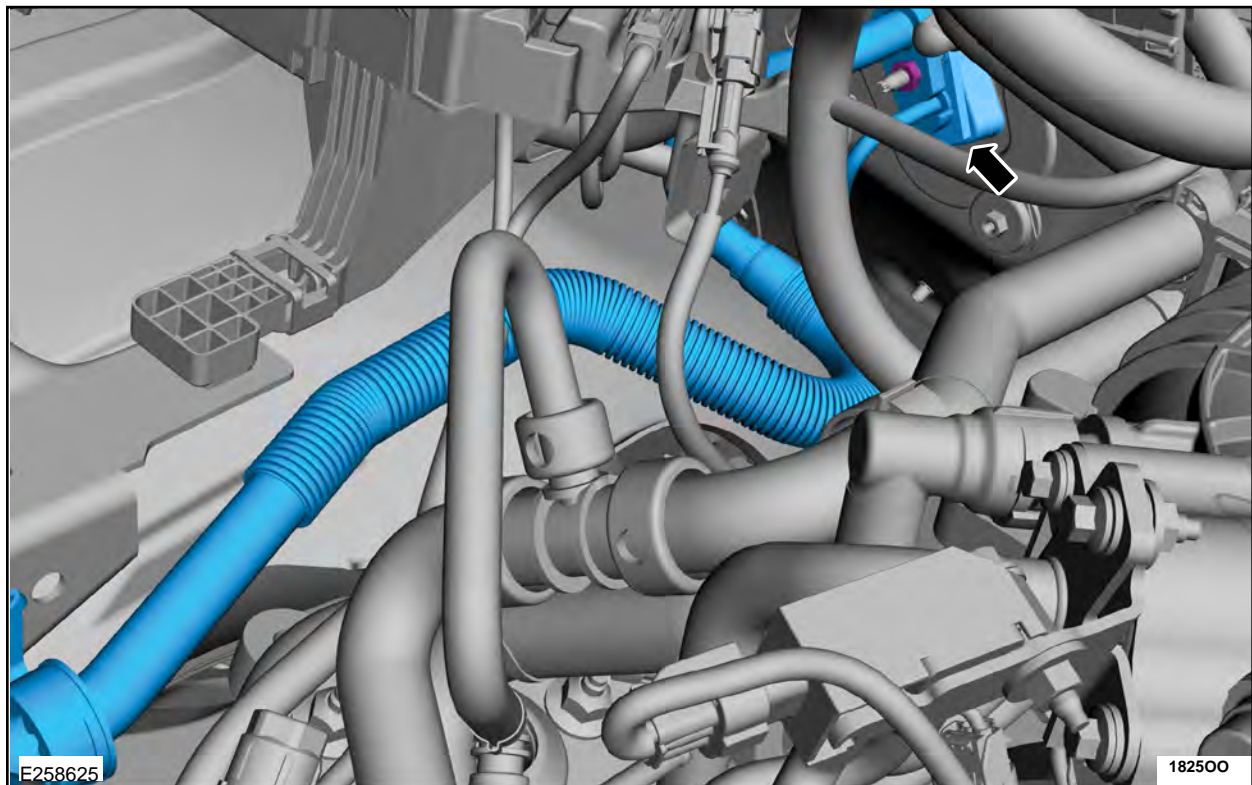

FIGURE 42



85. Install the thermostatic expansion valve manifold tube assembly fitting nuts to the rear evaporator inlet and outlet lines. See Figure 43.

- 1 Torque to 80 lb.in (9 Nm).
- 2 Torque to 159 lb.in (18 Nm).

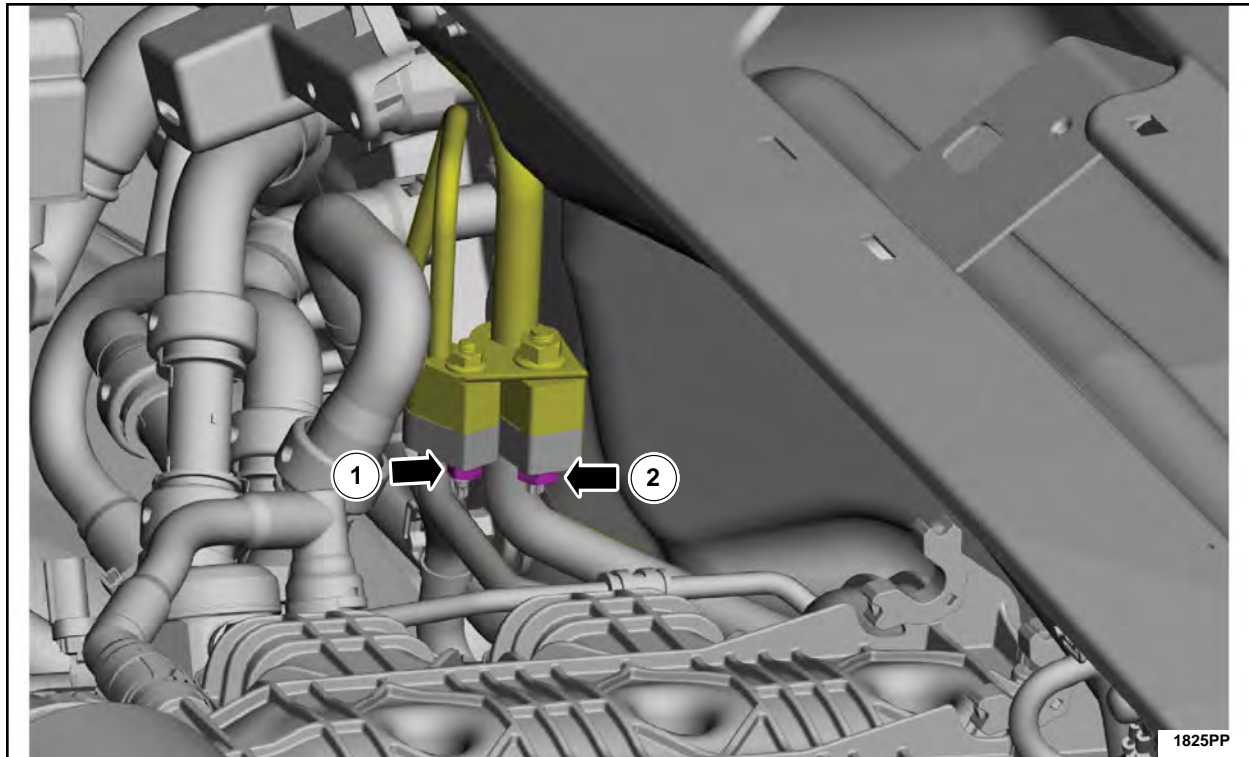

FIGURE 43



86. Install the front and rear heater core hoses to the heater core lines. See Figure 44.

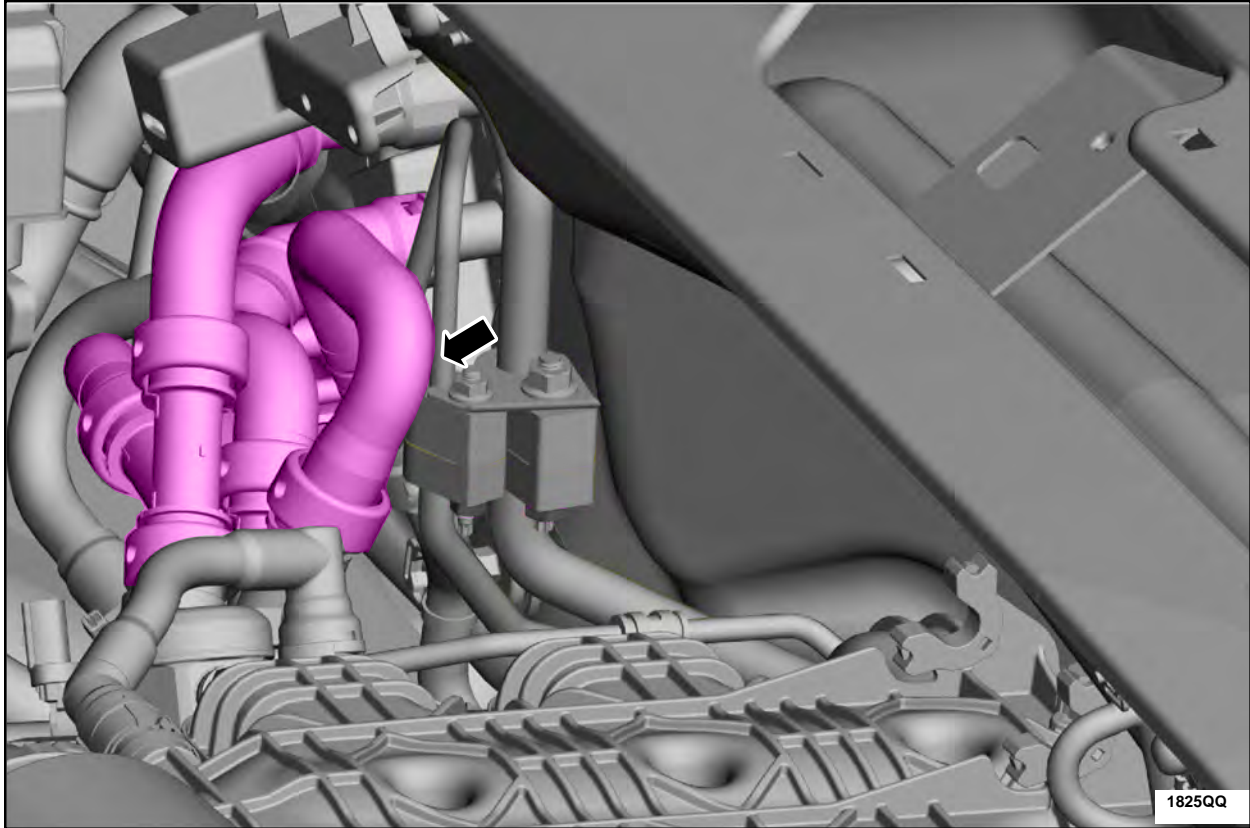

FIGURE 44



87. Install the PCM connectors and electrical connector. See Figure 45.

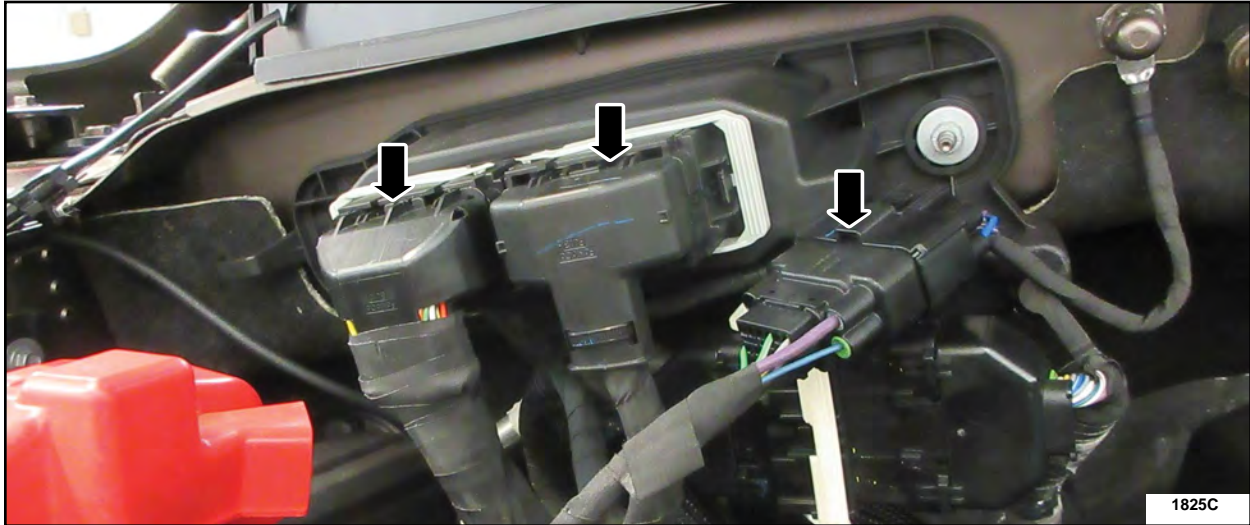

FIGURE 45

88. Install the three cables and nuts to the battery junction box, install the cover. See Figure 46.

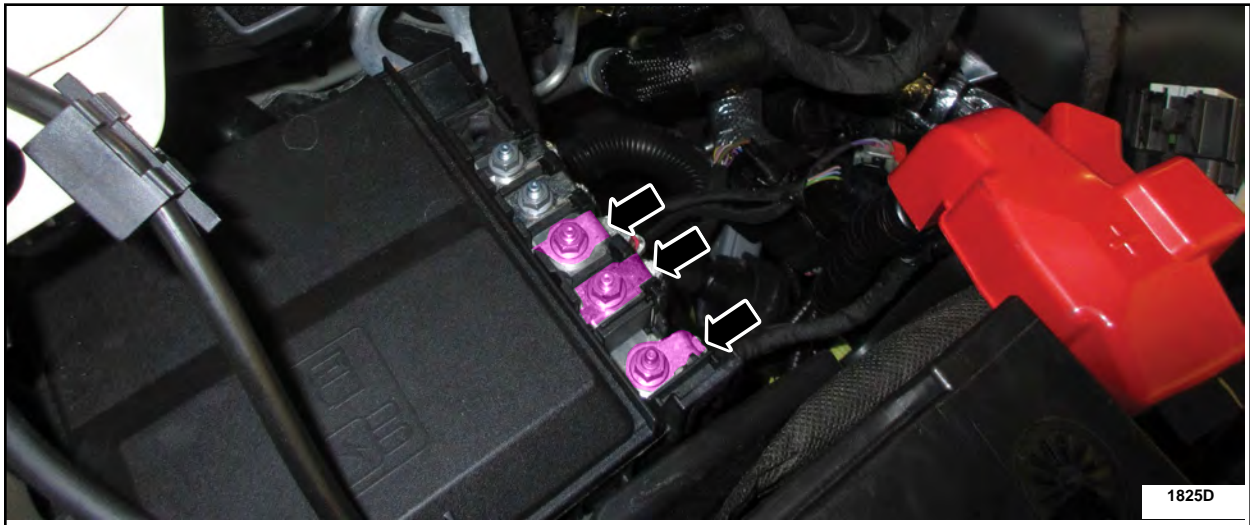

FIGURE 46

89. Install the RH Air Cleaner Outlet Pipe. Please refer to WSM procedures in section 303-12.

90. Install the RH Charge air cooler (CAC) intake pipe. Please refer to WSM procedures in section 303-12.

91. Install the Battery Tray and Battery. Please refer to WSM procedures in section 414-01.



92. Install the engine cover. See Figure 47.

NOTE: Expedition shown, Navigator similar.

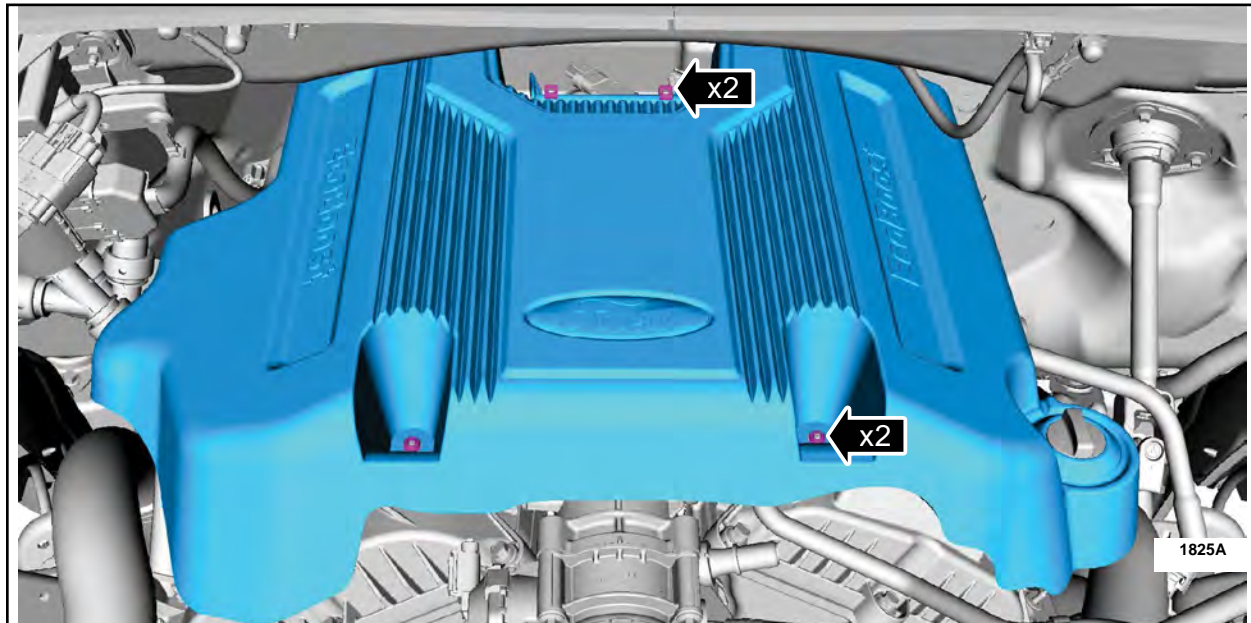

FIGURE 47

93. Charge the A/C system. Please refer to WSM procedures in section 412-00.
94. Repower the SRS system. Please refer to WSM procedures in section 501-20B.
95. Check for DTC's. Please refer to WSM procedures in section 100-00.
96. Perform Cooling System Draining, Vacuum Filling and Bleeding procedure. Please refer to WSM procedures in section 303-03.
97. Close liftgate.
98. Package the loaner equipment back into the original boxes and ship them back using the return shipping labels (be careful to apply correct shipping labels to correct boxes).

