



LTB01255NAS1

TECHNICAL BULLETIN

15 NOV 2018

© Jaguar Land Rover North America, LLC

NOTE: The information in Technical Bulletins is intended for use by trained, professional Technicians with the knowledge, tools, and equipment required to do the job properly and safely. It informs these Technicians of conditions that may occur on some vehicles, or provides information that could assist in proper vehicle service. The procedures should not be performed by 'do-it-yourselfers'. If you are not a Retailer, do not assume that a condition described affects your vehicle. Contact an authorized Land Rover service facility to determine whether this bulletin applies to a specific vehicle.

INFORMATION

SECTION:

307-00

SUBJECT/CONCERN:

Oil Leak From Transmission Case

AFFECTED VEHICLE RANGE:

MODEL:	MODEL YEAR:	VIN:	APPLICABILITY:
Discovery (LR)	2017-2018	000007-079570	V6 S/C 3.0L Petrol , Vehicles With: 8HP45 8-Speed Automatic Transmission AWD

MODEL:	MODEL YEAR:	VIN:	APPLICABILITY:
Range Rover Sport (LW)	2017-2018	124034-813922	V6 S/C 3.0L Petrol , Vehicles With: 8HP45 8-Speed Automatic Transmission AWD
Range Rover (LG)	2017-2018	320324-516165	V6 S/C 3.0L Petrol , Vehicles With: 8HP45 8-Speed Automatic Transmission AWD, Vehicles With: Twin Speed Transfer Case

MARKETS:

NORTH AMERICA

CONDITION SUMMARY:

SITUATION:

An oil leak from the transmission case may be evident.

CAUSE:

This may be caused by internal porosity in the automatic transmission, allowing oil to leak between the automatic transmission and the transfer case.

ACTION:

Should a customer express this concern, follow the Workshop Procedure below.

PARTS:

PART NUMBER	DESCRIPTION	QUANTITY
LR123853	Automatic transmission insert	1
TYG500130	Bolt(s) - Driveshaft flange	4
LR092696	Bolt(s) - Driveshaft flange	6
TYG500141	Bolt(s) - Driveshaft flange	6
IYX500050	Seal(s) - Transfer case	1
LR048842	Washer(s) - Single speed transfer case	2

PART NUMBER	DESCRIPTION	QUANTITY
IYF500030	Washer(s) - Twin speed transfer case	2
LR048849	Oil - Single speed transfer case	2
IYK500010	Oil - Twin speed transfer case	2
LR125418	Devcon putty	1

WARRANTY:

NOTES:

- Repair procedures are under constant review, and therefore times are subject to change; those quoted here must be taken as guidance only. Always refer to JLR claims submission system to obtain the latest repair time.
- The JLR Claims Submission System requires the use of causal part numbers. Labor only claims must show the causal part number with a quantity of zero.

DESCRIPTION	SRO	TIME (HOURS)	CONDITION CODE	CAUSAL PART
Automatic transmission insert - With Single speed transfer case - Install - Discovery (L462)	44.20.89.01	9.4	D1	LR082674
Automatic transmission insert - With Twin speed transfer case - Install - Discovery (L462)	44.20.89.01	9.3	D1	LR082674
Automatic transmission insert - Install - Range Rover Sport (L494)	44.20.89.01	9.0	D1	LR082674
Automatic transmission insert - Install - Range Rover (L405)	44.20.89.01	9.0	D1	LR082674

NOTE:

Normal Warranty procedures apply.

SERVICE INSTRUCTION:

⚠ WARNING:

Safety goggles and protective gloves and mask must be worn when using Devcon putty.

- 1 Remove the transfer case (see TOPIx Workshop Manual section 308-07: Manual Transmission/Transaxle, Clutch and Transfer Case -- Removal -- Transfer Case).

2 **△ NOTE:**

Make sure the Devcon putty does not come into contact with the transmission output shaft.

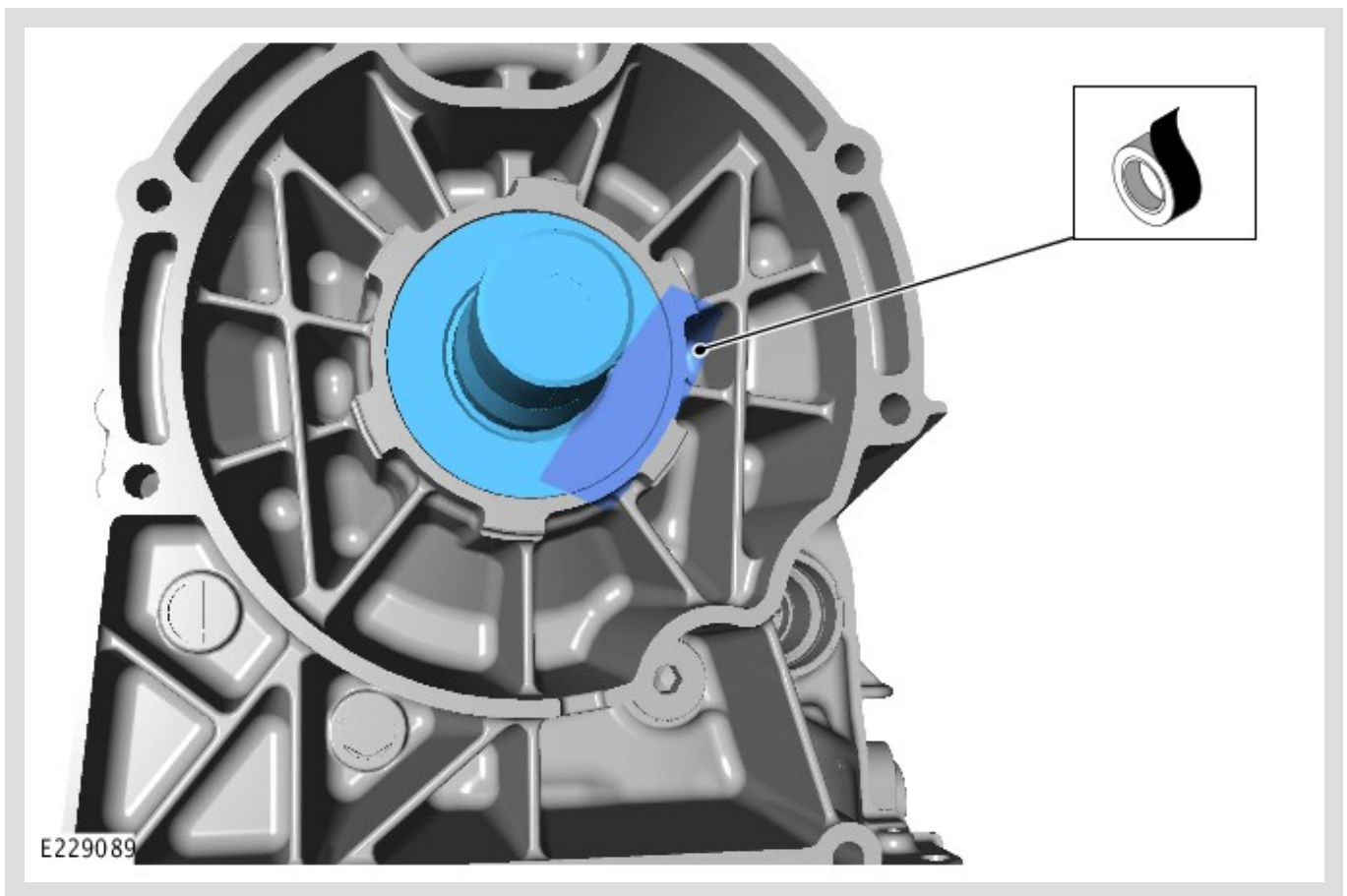

Apply suitable protective tape to the highlighted area of the transmission.

3 **△ NOTES:**

- To assist in carrying out the repair in the correct method, watch the video before completing Steps 4-6.

- This video can only be viewed in Internet Explorer.

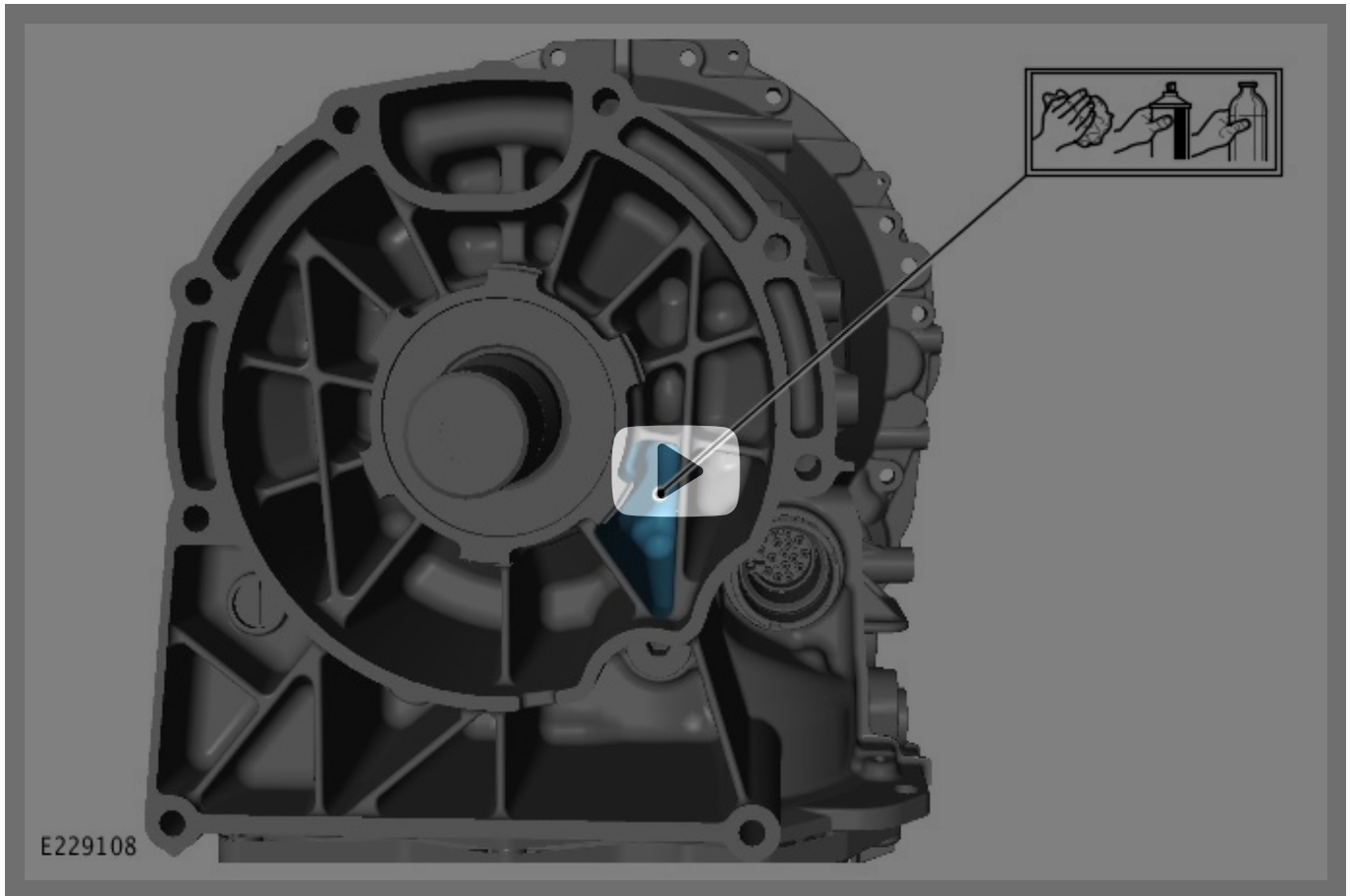

Use a suitable solvent-based cleaning fluid to thoroughly clean the highlighted area of the transmission.

4

ⓘ CAUTION:

The highlighted area of the transmission must be free of all oil and contamination before proceeding.

△ NOTES:

- Devcon putting mix ratio: 4 parts resin / 1 part hardener. Refer to the manufacturer's instructions for more information.
- Make sure that the highlighted area of the transmission is fully covered by a layer of Devcon putty.

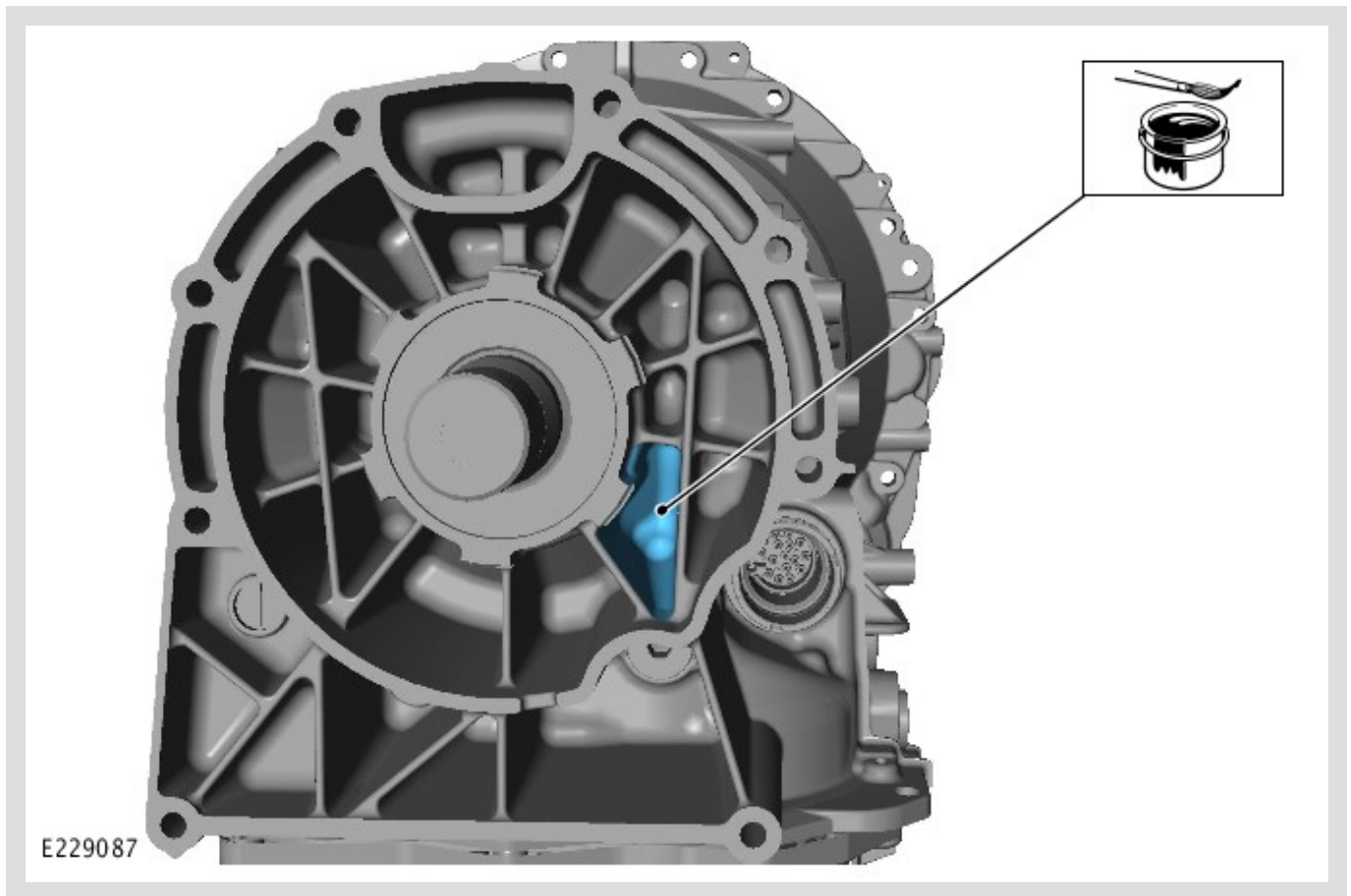

Apply an even layer of Devcon putty to the highlighted area of the transmission.

5

⚠ CAUTION:

The transmission insert must be installed to at least 9 mm below the outer edge of the transmission housing.



Use a suitable tool to push the transmission insert into the area shown.

6

⚠ CAUTION:

Make sure that all machined faces are free of any contamination, Devcon, etc.

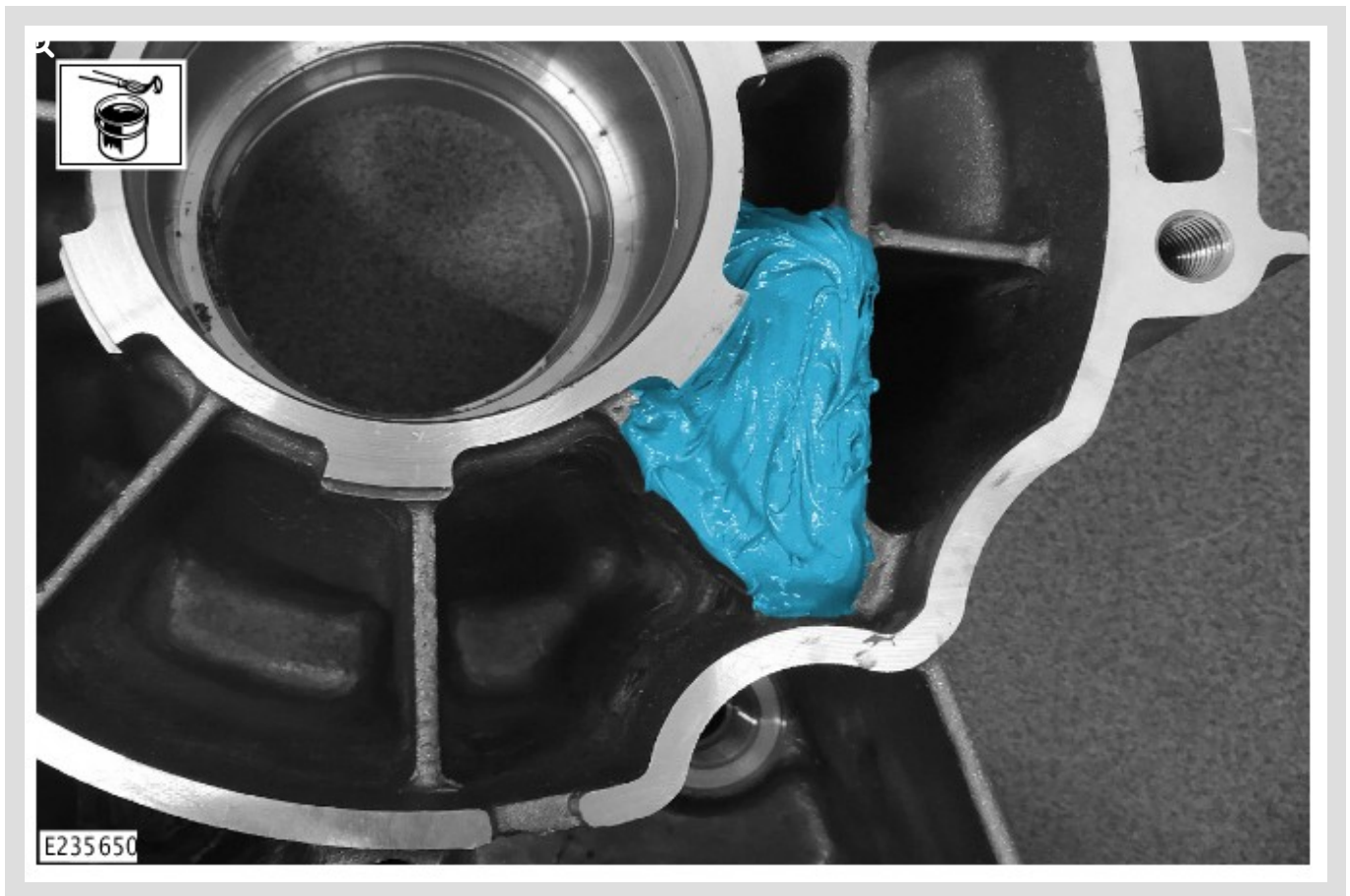

Apply an even layer of Devcon putty to the transmission insert until it is completely filled and covered.

7 Allow the Devcon putty to completely cure:

- The transfer case must be left for at least 8 hours before installation.
- The ambient air temperature must remain above 24°C for the initial 45 minutes.
- The ambient air temperature must remain above 16°C for the remaining 7 hours, 15 minutes.
- Refer to the manufacturer's instructions for more information.

8 Install the transfer case (see TOPIx Workshop Manual section 308-07: Manual Transmission/Transaxle, Clutch and Transfer Case -- Installation -- Transfer Case).