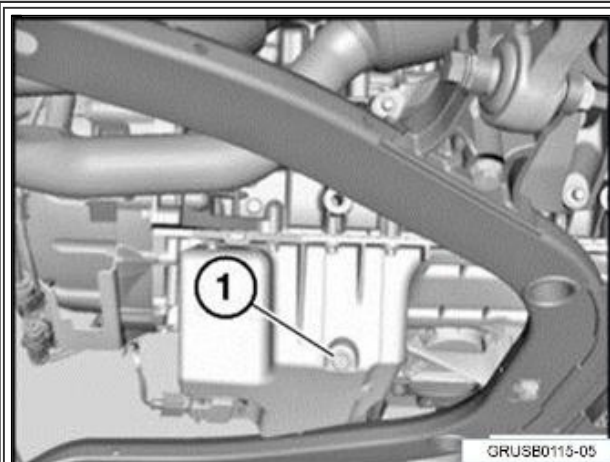

**SUBJECT****Engine Crankcase Oil Pans: Stripped or Crossed Threaded Drain Plugs****MODEL**

All

SITUATION

Based on the analysis of parts received by the Warranty Parts Return Center (WPRC), engine crankcase oil pans are being replaced under warranty or goodwill because the threaded drain hole is stripped or crossed-threaded upon removal and/or installation of the drain plug.

PROCEDURE

When draining the engine oil:

- Do not use power tools to remove and install the oil pan drain plug (1);
- Do not over-tighten the drain plug when installing; and
- Always refer to ISTA for the applicable repair instructions and proper drain plug tightening torque specification.

WARRANTY INFORMATION

A stripped and crossed-threaded engine crankcase oil pan drain plug hole is not considered a defect in materials and workmanship, nor as a “wear item” under the maintenance program.

[Copyright ©2015 BMW of North America, Inc.]