

Subject:

KNOCKING NOISE FROM FRONT SUSPENSION WHEN DRIVING OVER BUMPS AT LOW SPEEDS

Bulletin No.: 02-017/18

Last Issued: 11/02/2018

APPLICABLE MODEL(S)/VINS

2016-2017 Mazda2 (Mexico spec)

DESCRIPTION

Some vehicles may experience one or both of the following noises from the front shock absorber.

- A knocking/popping noise occurs when passing over speed bumps.
- A squeaking noise occurs when turning the steering wheel with vehicle at a standstill or at low speed.

This is caused by the bump stopper (2) contacting the strut bearing (3) when the front shock absorber (1) is compressed.

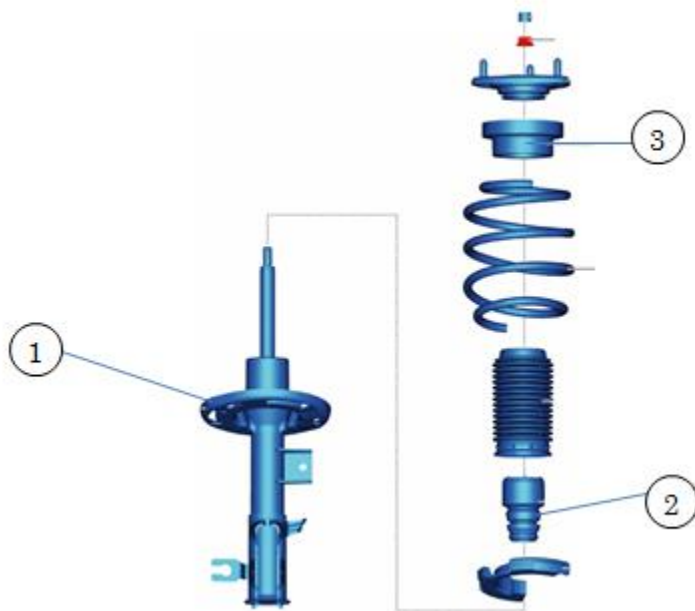

To eliminate this concern, the shape of the bump stopper has been modified.

CONSUMER NOTICE: The information and instructions in this bulletin are intended for use by skilled technicians. Mazda technicians utilize the proper tools/equipment and take training to correctly and safely maintain Mazda vehicles. These instructions should not be performed by "do-it-yourselfers." Customers should not assume this bulletin applies to their vehicle or that their vehicle will develop the described concern. To determine if the information applies, customers should contact their nearest authorized Mazda dealership. Mazda North American Operations reserves the right to alter the specifications and contents of this bulletin without obligation or advance notice. All rights reserved. No part of this bulletin may be reproduced in any form or by any means, electronic or mechanical---including photocopying and recording and the use of any kind of information storage and retrieval system ---without permission in writing.

Customers having this concern should have their vehicle repaired using the following repair procedure.

REPAIR PROCEDURE

1. Verify concern.
2. Check to see if the noise is coming from the front shock absorber(s).
 - If the noise is coming from the front shock absorber(s), go to the next step.
 - If the noise is not coming from the front shock absorber(s), this TSB does not apply.
3. Replace the bump stopper (both sides) with a modified one according to instructions on MGSS (FRONT SHOCK ABSORBER AND COIL SPRING DISASSEMBLY/ASSEMBLY).

NOTE: Before removing the mounting rubber, put a position mark on it and the shock absorber so the mounting rubber can be installed back in the original position.

CAUTION: It is not necessary to adjust the front wheel alignment because the front shock absorber and the mounting rubber are not replaced. However, make sure to install the mounting rubber to the original position.



4. Apply approx. 3 - 5 gram of rubber grease on the hatched areas as shown (all the way around).

NOTE: DO NOT apply grease on the threads (1).

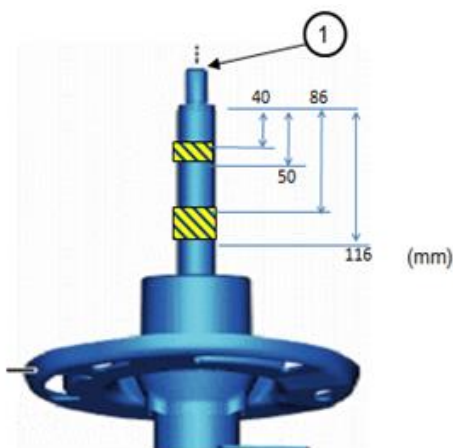

CONSUMER NOTICE: The information and instructions in this bulletin are intended for use by skilled technicians. Mazda technicians utilize the proper tools/equipment and take training to correctly and safely maintain Mazda vehicles. These instructions should not be performed by "do-it-yourselfers." Customers should not assume this bulletin applies to their vehicle or that their vehicle will develop the described concern. To determine if the information applies, customers should contact their nearest authorized Mazda dealership. Mazda North American Operations reserves the right to alter the specifications and contents of this bulletin without obligation or advance notice. All rights reserved. No part of this bulletin may be reproduced in any form or by any means, electronic or mechanical---including photocopying and recording and the use of any kind of information storage and retrieval system ---without permission in writing.

5. Install the shock absorber according to the instructions on MGSS (FRONT SHOCK ABSORBER AND COIL SPRING DISASSEMBLY/ASSEMBLY).

6. Verify repair.

PARTS INFORMATION

Parts Number	Description	Qty.	Notes
DA6G-34-111	Bump Stopper	2	Mexico built
0118-77-761	Grease	1	One tube of grease can repair 20 vehicles.
9YB0-41-237	Nut, Piston Rod	2	[R]

[R] Replace

WARRANTY INFORMATION

NOTE:

- This warranty information applies only to verified customer complaints on vehicles eligible for warranty repair.
- This repair will be covered under Mazda's New Vehicle Limited Warranty term.
- Additional diagnostic time cannot be claimed for this repair.

Warranty Type	A
Symptom Code	82
Damage Code	97
Part Number Main Cause	**** 34 111*
Quantity	2
Operation Number / Labor Hours:	XXP7FARX / 0.7 Hrs.

CONSUMER NOTICE: The information and instructions in this bulletin are intended for use by skilled technicians. Mazda technicians utilize the proper tools/equipment and take training to correctly and safely maintain Mazda vehicles. These instructions should not be performed by "do-it-yourselfers." Customers should not assume this bulletin applies to their vehicle or that their vehicle will develop the described concern. To determine if the information applies, customers should contact their nearest authorized Mazda dealership. Mazda North American Operations reserves the right to alter the specifications and contents of this bulletin without obligation or advance notice. All rights reserved. No part of this bulletin may be reproduced in any form or by any means, electronic or mechanical---including photocopying and recording and the use of any kind of information storage and retrieval system ---without permission in writing.