



Technical Service Bulletin

Technical Service Bulletin: TSB180180	Released Date: 19-Dec-2018
Campaign #3596 - C550D5E Alternator Ground Strap Installation	

Campaign #3596 - C550D5E Alternator Ground Strap Installation

Warranty Statement

The information in this document authorizes specific changes to the repair practice for failures covered under product warranty coverages.

Contents

Product Affected

- C500D5E (QSX15)
- C550D5E (QSX15)
- C550D5E Enclosed (QSX15)

Issue

Symptom:

- The ground strap of the generator was found not installed.

Root Cause:

- The drawing of previous version, which was used for installation, did not contain the call for ground strap.

Verification/Confirmation

- Refer to the list of genset serial numbers below. See Table 2.
- Remove the cover of terminal box, check if there is ground strap in it. The picture below is the inside of terminal box with ground strap installed for reference.

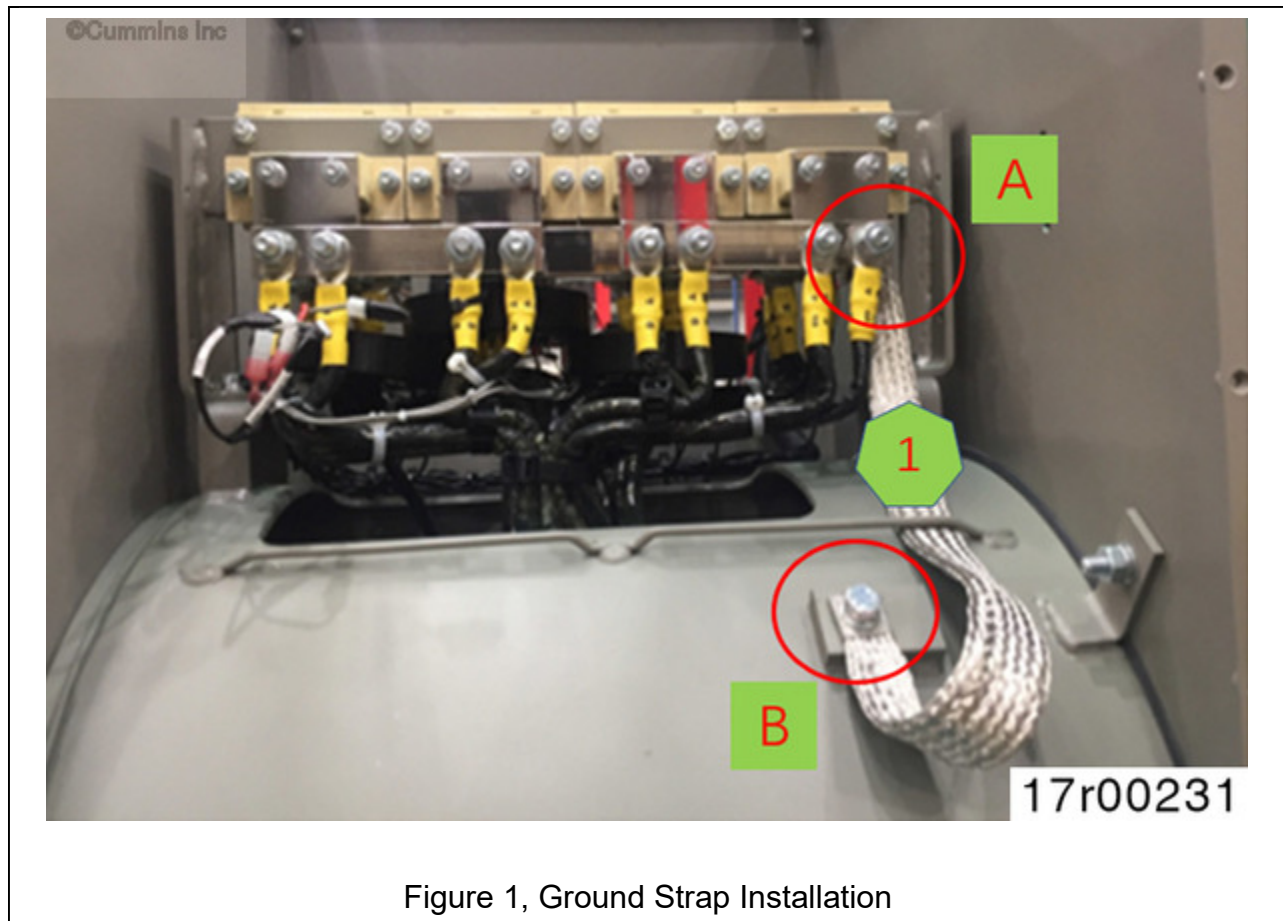

Figure 1, Ground Strap Installation

Resolution

Install the ground strap on the alternator.

Service Instructions

Fail Code = **JTTXMP**

Account code: **65**

Campaign code: **3596**

1 Tech with 1 trip of 200km(5h) will be allowed for each unit

SRTs:

00-902: Administrative Time: 0.7

26-0AS: Bus bar housing – R&I: 0.3

99-999: Ground Strap Installation: 0.5

Expiration date: 31 June 2019

Work Instruction:

Communicate with the customer on the design of their grounding system, and check with the customer that the ground strap is necessary. The steps are listed below:

1. Remove the alternator terminal box cover.
2. Remove the nut on the N phase screw in item A, and install the terminal on one side of the ground strap to the screw. Replace and tighten the nut.
3. Put the terminal on the other side of the ground strap on the hole of the alternator in item B, put flat washer and spring washer on it, then install the screw and tighten. Make sure the strap will not touch other phase screws.
4. Install the alternator terminal box cover.

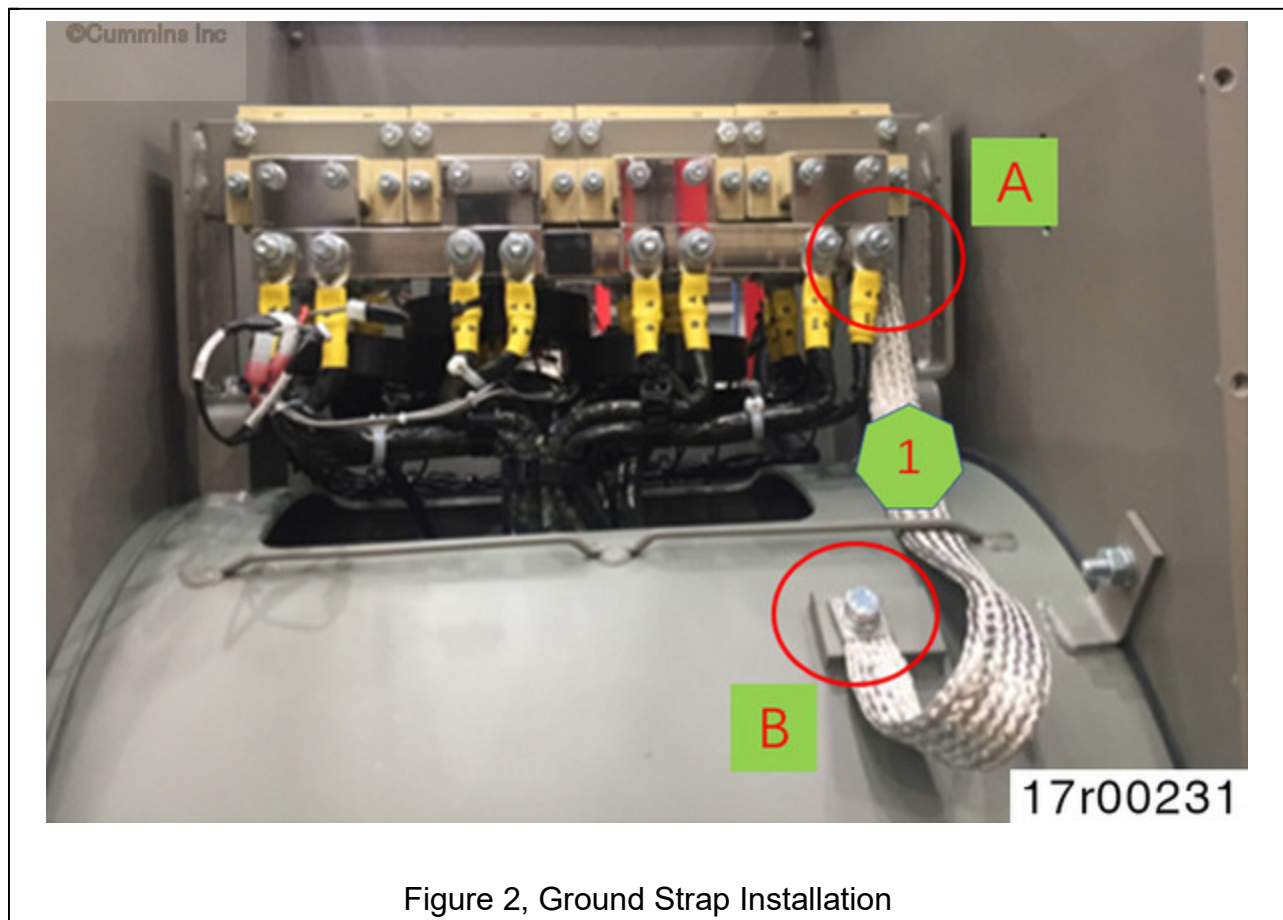

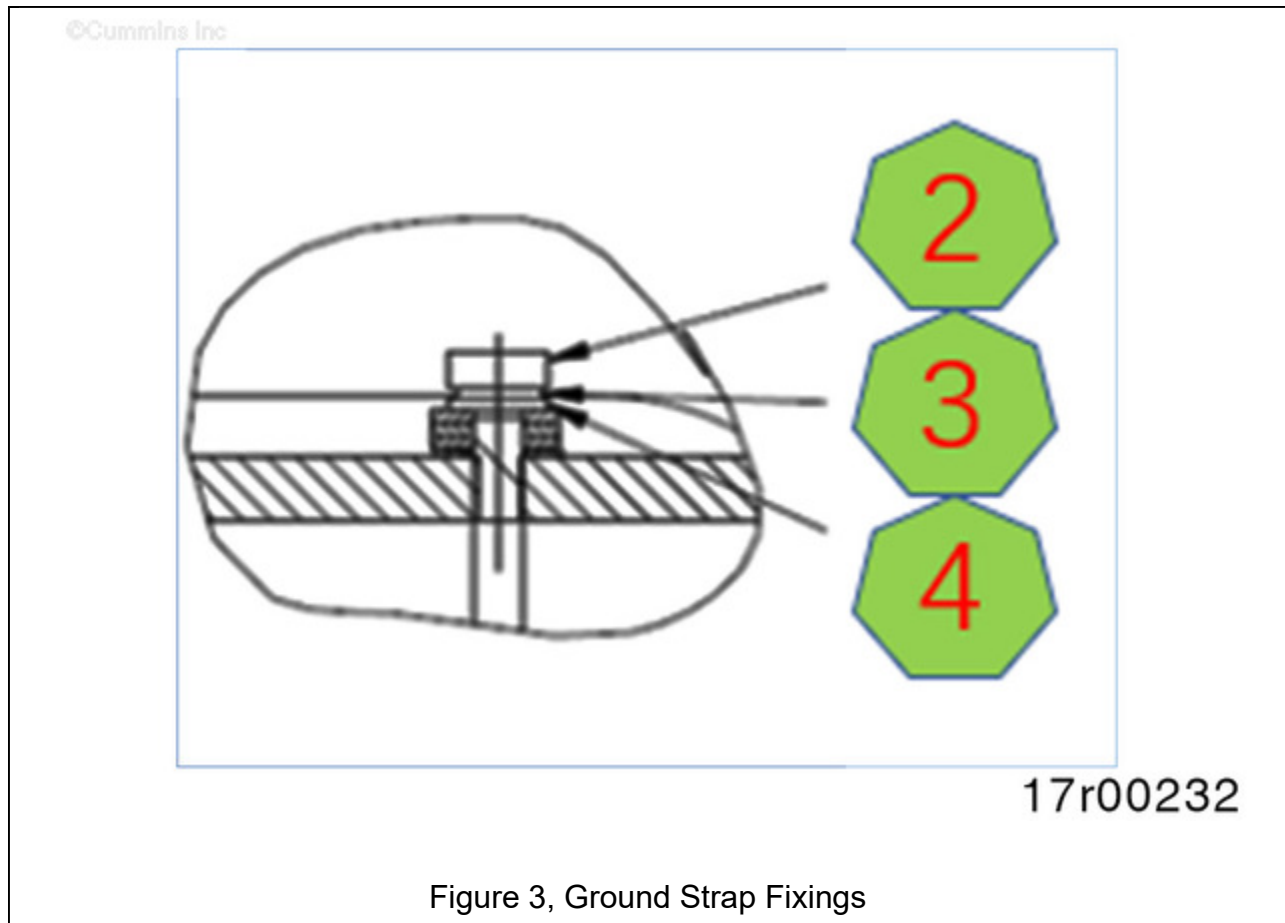

Figure 3, Ground Strap Fixings

Service Parts Availability

Service parts are available. See Table 1 for part numbers.

Table 1, Part Numbers				
	Part number	Description	Qty per genset	Find number
1	0337-3586-01	Ground strap	1	1
2	0800-3017-37	Screw M10x25	1	2
3	0850-0114-55	Spring washer M10	1	3
4	0526-0399-62	Flat washer M10	1	4

Production Status

Table 2, Affected Generator Sets			
GSN	Model	GSN	Model

Table 2, Affected Generator Sets			
I17H007844	C550D5E Enclosed	I17H007916	C550D5E Enclosed
I17H007845	C550D5E Enclosed	I17H007917	C550D5E Enclosed
I17H007842	C550D5E Enclosed	I17H007918	C550D5E Enclosed
I17H007843	C550D5E Enclosed	I17H007919	C550D5E Enclosed
I17H007838	C550D5E Enclosed	I17H007920	C550D5E Enclosed
I17H007839	C550D5E Enclosed	I17H007907	C550D5E Enclosed
I17H007840	C550D5E Enclosed	I17H007908	C550D5E Enclosed
I17H007841	C550D5E Enclosed	I17H007909	C550D5E Enclosed
I17H007864	C550D5E Enclosed	I17H007910	C550D5E Enclosed
I17H007865	C550D5E Enclosed	I17H007903	C550D5E Enclosed
I17H007866	C550D5E Enclosed	I17H007904	C550D5E Enclosed
I17H007867	C550D5E Enclosed	I17H007905	C550D5E Enclosed
I17H007868	C550D5E Enclosed	I17H007906	C550D5E Enclosed
I17H007869	C550D5E Enclosed	I17H007921	C550D5E
I17H007870	C550D5E Enclosed	I17H007922	C550D5E
I17H007871	C550D5E Enclosed	I17H007958	C550D5E
I17H007872	C550D5E Enclosed	I17H007959	C550D5E

Table 2, Affected Generator Sets			
I17H007873	C550D5E Enclosed	J17H007960	C550D5E
I17H007874	C550D5E Enclosed	I17H007962	C550D5E
I17H007875	C550D5E Enclosed	J17H007961	C550D5E
I17H007876	C550D5E Enclosed	L17H007982	C500D5E
I17H007877	C550D5E Enclosed	J17H007968	C550D5E Enclosed
I17H007886	C550D5E Enclosed	J17H007969	C550D5E Enclosed
I17H007887	C550D5E Enclosed	J17H007970	C550D5E Enclosed
I17H007888	C550D5E Enclosed	J17H007971	C550D5E Enclosed
I17H007889	C550D5E Enclosed	J17H007972	C550D5E Enclosed
I17H007913	C550D5E Enclosed	J17H007973	C550D5E Enclosed
I17H007914	C550D5E Enclosed	J17H007974	C550D5E Enclosed
I17H007915	C550D5E Enclosed		

Document History

Date	Details
2018-12-18	Module Created

Last Modified: 19-Dec-2018
