



---

# SERVICE BULLETIN

---

Classification:

EC18-033

Reference:

NTB18-084

Date:

December 13, 2018

---

## 2017-2018 ROGUE SPORT; REDUCED POWER DUE TO SNOW INGESTION

**APPLIED VEHICLES:** 2017-2018 Rogue Sport (J11)

### IF YOU CONFIRM

- An Applied Vehicle experiences reduced power during extremely heavy snow fall,

**And**

- Snow is found inside the air cleaner case.

**NOTE:** The MIL may be ON with DTC P0101 (MAF SEN/CIRCUIT B1) stored.

### ACTION

1. Remove the front grille spacer.
2. Install foam blocks listed in the Parts Information.
3. Install the new front grille spacer.

**IMPORTANT:** The purpose of ACTION (above) is to give you a quick idea of the work you will be performing. You **MUST** closely follow the entire SERVICE PROCEDURE as it contains information that is essential to successfully completing this repair.

Nissan Bulletins are intended for use by qualified technicians, not 'do-it-yourselfers'. Qualified technicians are properly trained individuals who have the equipment, tools, safety instruction, and know-how to do a job properly and safely. NOTE: If you believe that a described condition may apply to a particular vehicle, DO NOT assume that it does. See your Nissan dealer to determine if this applies to your vehicle.

## SERVICE PROCEDURE

1. Open the hood.
2. Remove any snow from inside of the air duct assembly, resonator, and the air cleaner case.
  - Refer to the ESM for air duct assembly, resonator, and the air cleaner case removal; **Inspection, Removal, and Installation > ENGINE > ENGINE MECHANICAL > REMOVAL AND INSTALLATION > AIR CLEANER AND AIR DUCT.**
3. Replace the air cleaner filter.
  - Refer to the ESM for air cleaner replacement; **Inspection, Removal, and Installation > ENGINE > ENGINE MECHANICAL > PERIODIC MAINTENANCE > AIR CLEANER FILTER.**
4. Reinstall the air duct assembly, resonator, and the air cleaner case.
5. Remove the front grille spacer from the vehicle (see Figure 1).

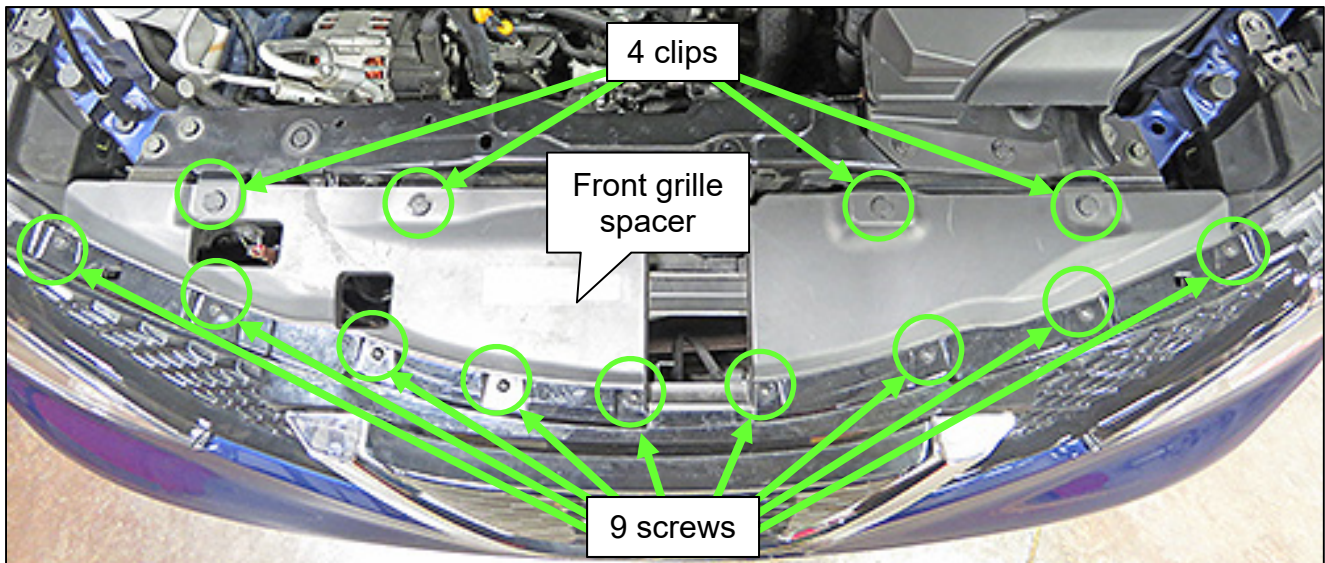

Figure 1

6. Clean the areas of the radiator mounting bracket, shown highlighted in Figure 3, with 50% isopropyl alcohol.

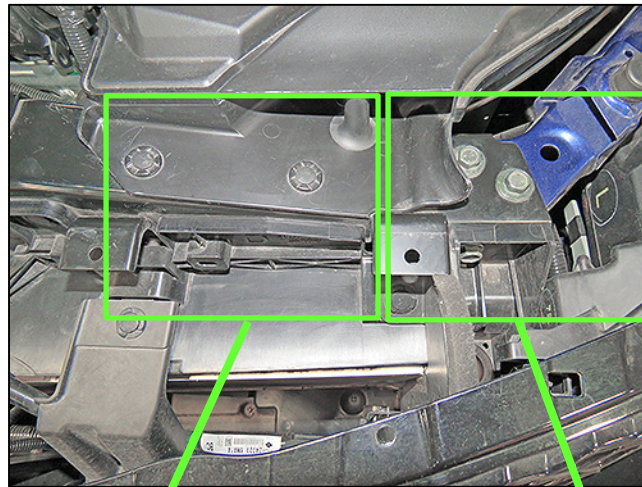

Figure 2

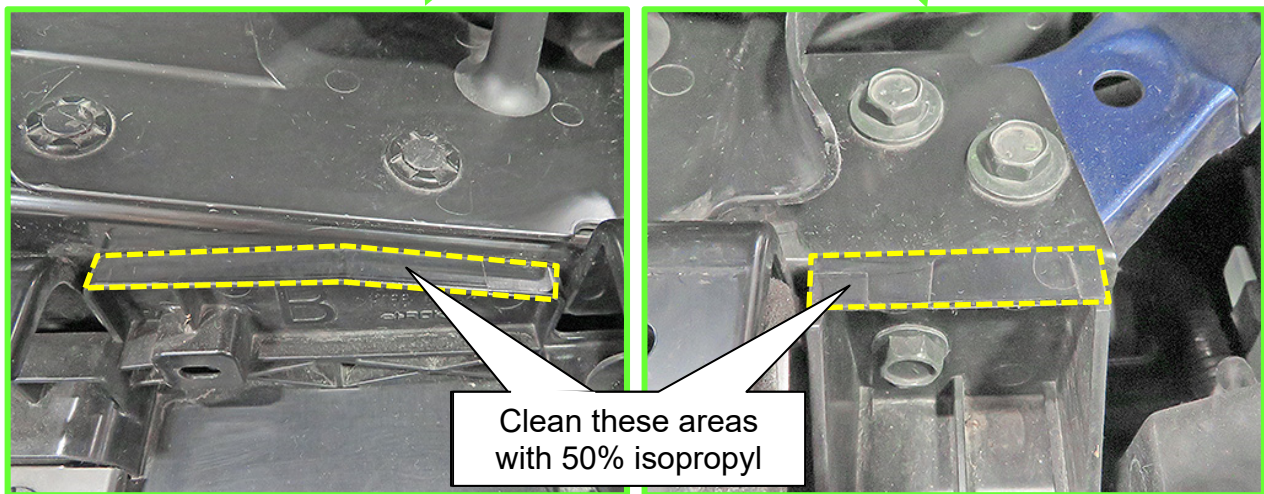

Figure 3

7. Install SEAL 1 (10 x 20 x 116 mm foam block) onto the radiator mounting bracket as follows:
- Confirm that SEAL 1 is oriented with the adhesive strip facing down and toward the rear of the vehicle (Figure 4).

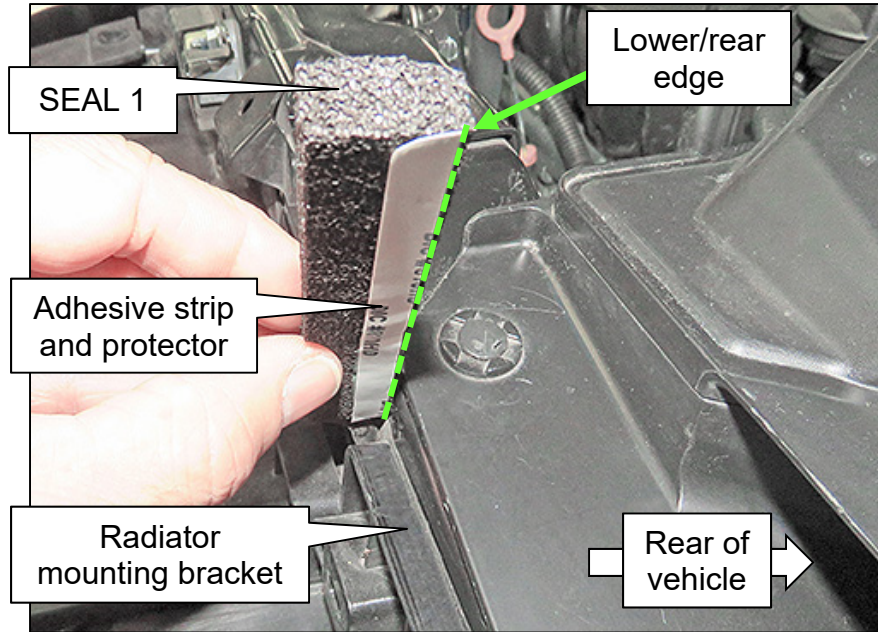

Figure 4

- Remove the adhesive strip protector.
- Attach SEAL 1 so that:
  - the lower/rear edge of SEAL 1 (Figure 4) is placed on the radiator mounting bracket where shown in Figure 5,

**And**

  - it is centered on the radiator mounting bracket as shown in Figure 6.

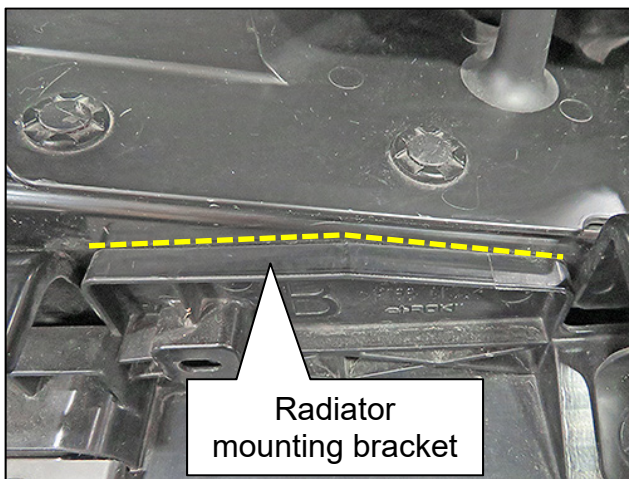

Figure 5

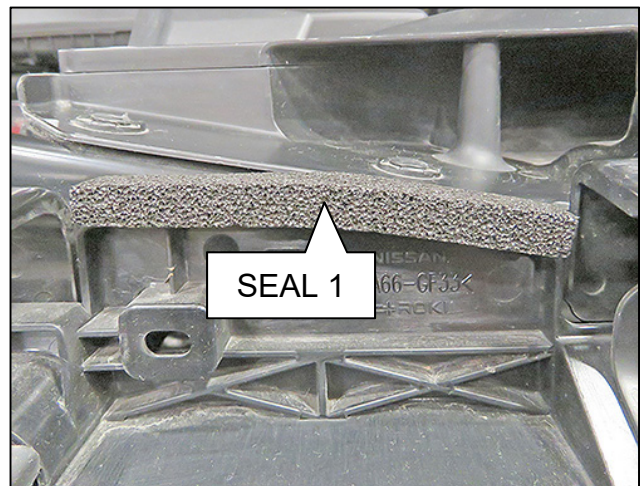

Figure 6

8. Install SEAL 2 (10 x 20 x 70 mm foam block) onto the radiator mounting bracket as follows:
- a. Confirm that SEAL 2 is oriented with the adhesive strip facing down and toward the rear of the vehicle (Figure 7).

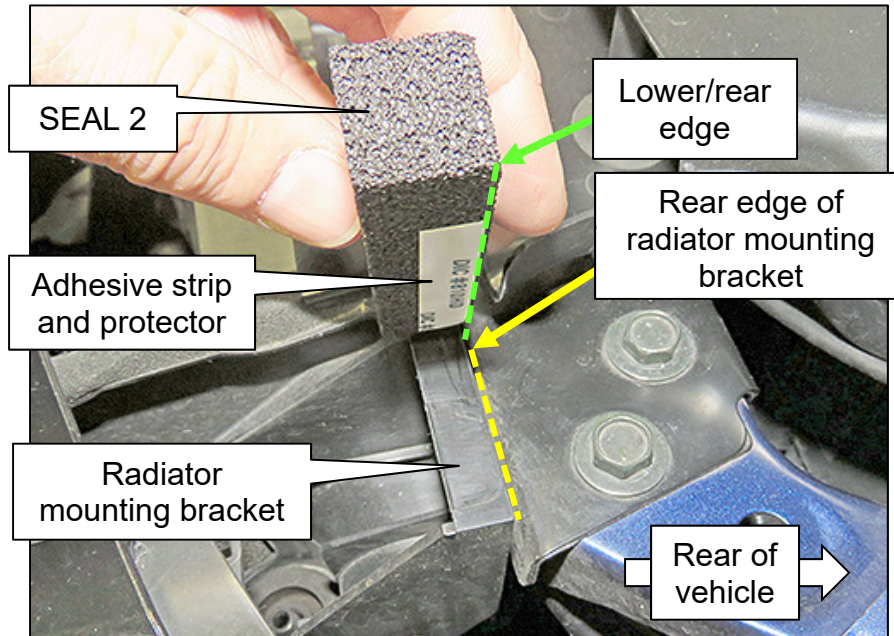

Figure 7

- b. Remove the adhesive strip protector.
- c. Attach SEAL 2 so that:
- the lower/rear edge of SEAL 2 (Figure 7) is aligned with the rear edge of the radiator mounting bracket where shown in Figure 7 and Figure 8,
- And**
- it is up against the edge of grille spacer mount as shown in Figure 9.

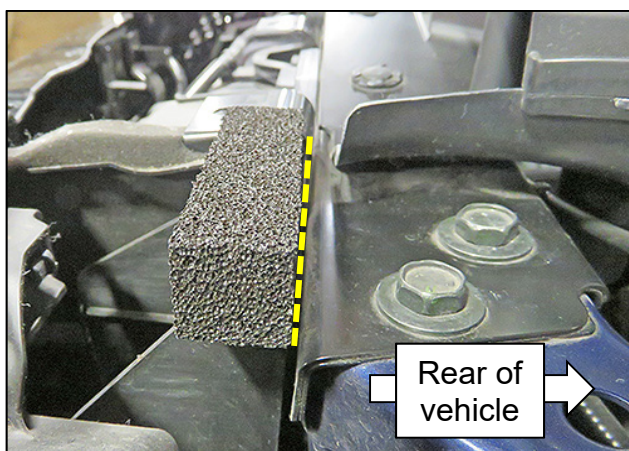

Figure 8

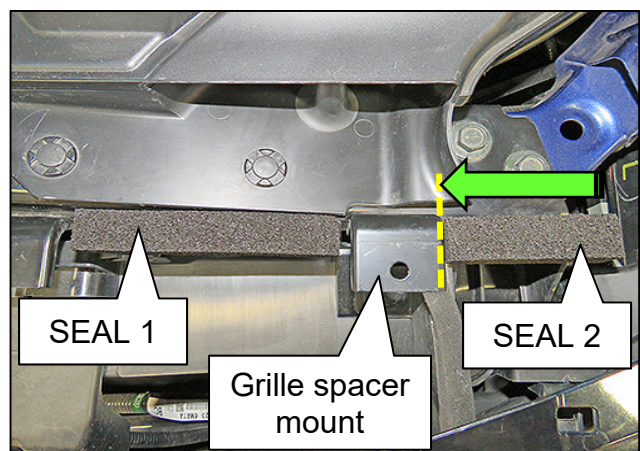

Figure 9

9. Clean the areas of Air Duct 1 shown highlighted in Figure 10 with 50% isopropyl alcohol.

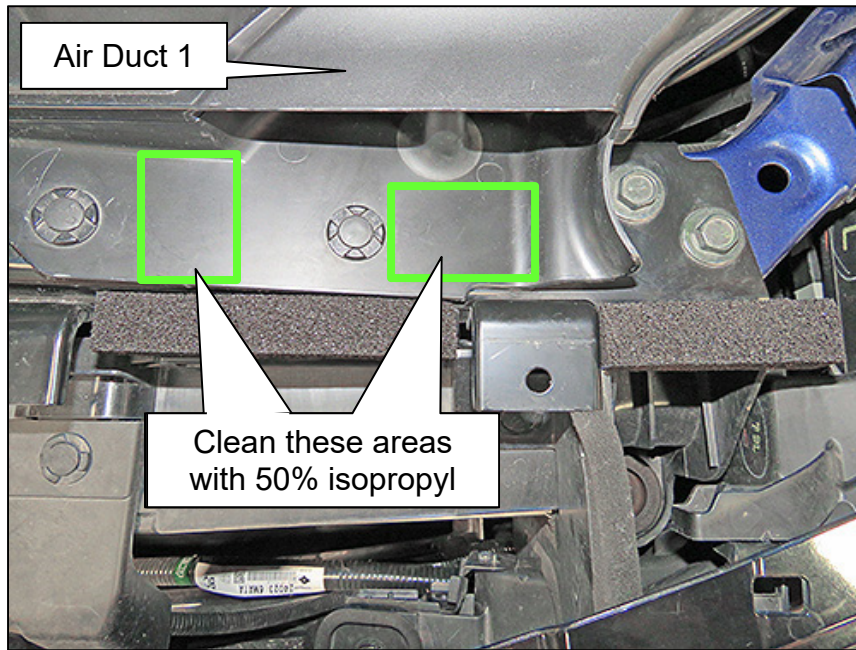

Figure 10

10. Install two (2) SEAL-AIR DUCT, DUST SIDE (20 x 30 x 40 mm foam block) onto Air Duct 1 as follows:
- Remove the adhesive strip protector from one of the 20 x 30 x 40 mm foam blocks.
  - Install the first 20 x 30 x 40 mm foam block so that:
    - it is aligned with the front edge of Air Duct 1 as shown in Figure 11,
- And**
- is aligned with the edge of the Air Duct 1 opening as shown in Figure 12.

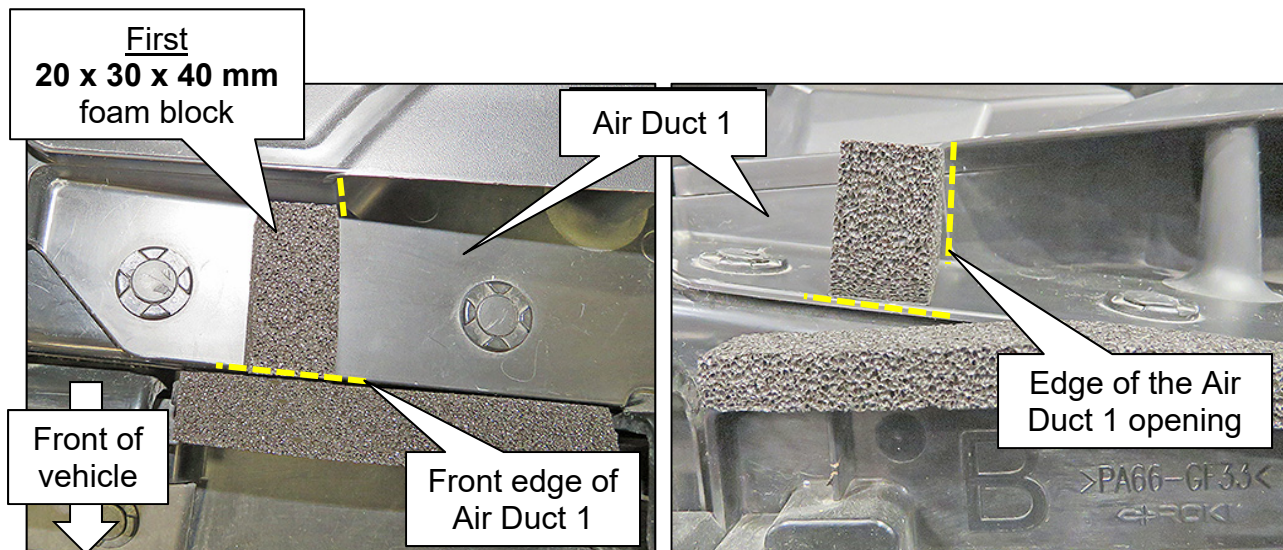

Figure 11

Figure 12

- c. Remove the adhesive strip protector from the second **20 x 30 x 40 mm** foam block.
- d. Install the second **20 x 30 x 40 mm** foam block so that:
- it is up against the clip that retains Air Duct 1 as shown in Figure 13,
- And**
- is aligned with the centerline of both of the clips that retain Air Duct 1 as shown in Figure 13.

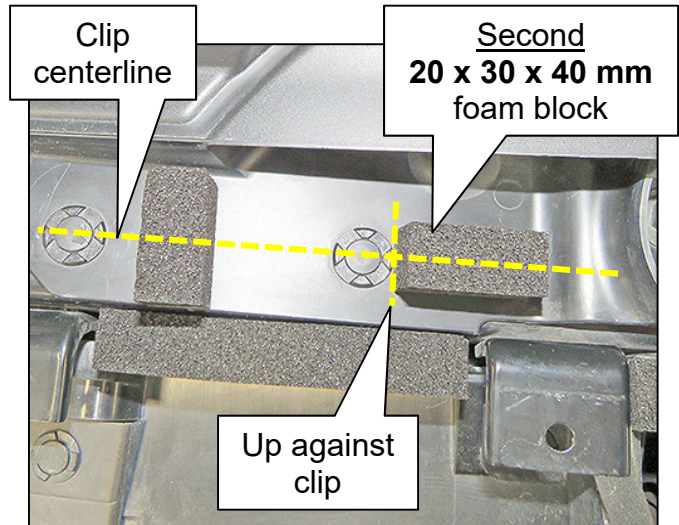

Figure 13

11. Clean the area of the new front grille spacer shown highlighted in Figure 14 with 50% isopropyl alcohol.

**NOTE:** See the Parts Information for the new front grille spacer.

12. Install MOUNTING (**20 x 30 x 100 mm** foam block) onto the new grille spacer as follows:

- a. Remove the adhesive strip protector from the **20 x 30 x 100 mm** foam block.
- b. Install the **20 x 30 x 100 mm** foam block so that:
  - it is aligned with the bottom of the rear edge of the front grille spacer, with a gap of 2.5 mm as shown in Figure 15 and Figure 16,

**And**

- is centered (Figure 15) over the raised molding shown in Figure 14.

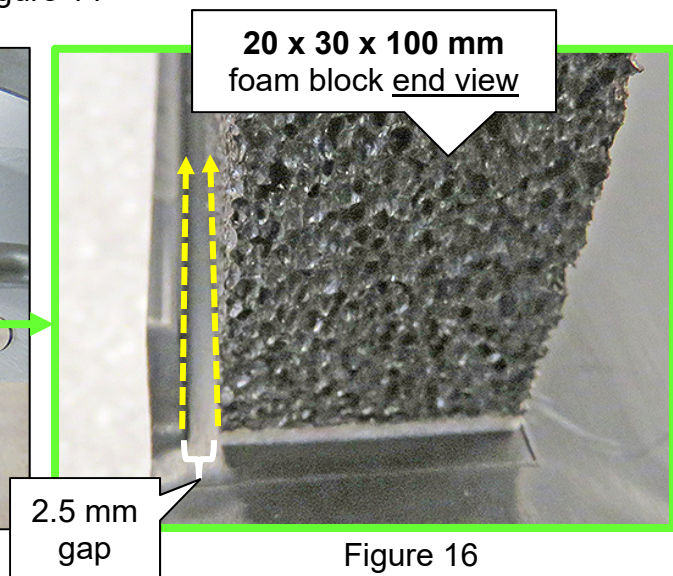
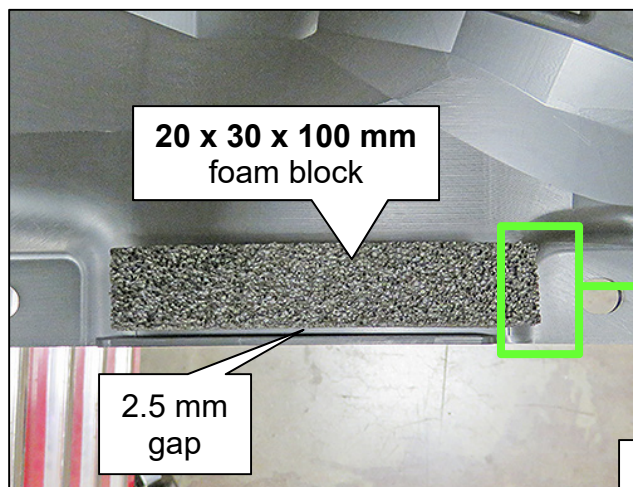
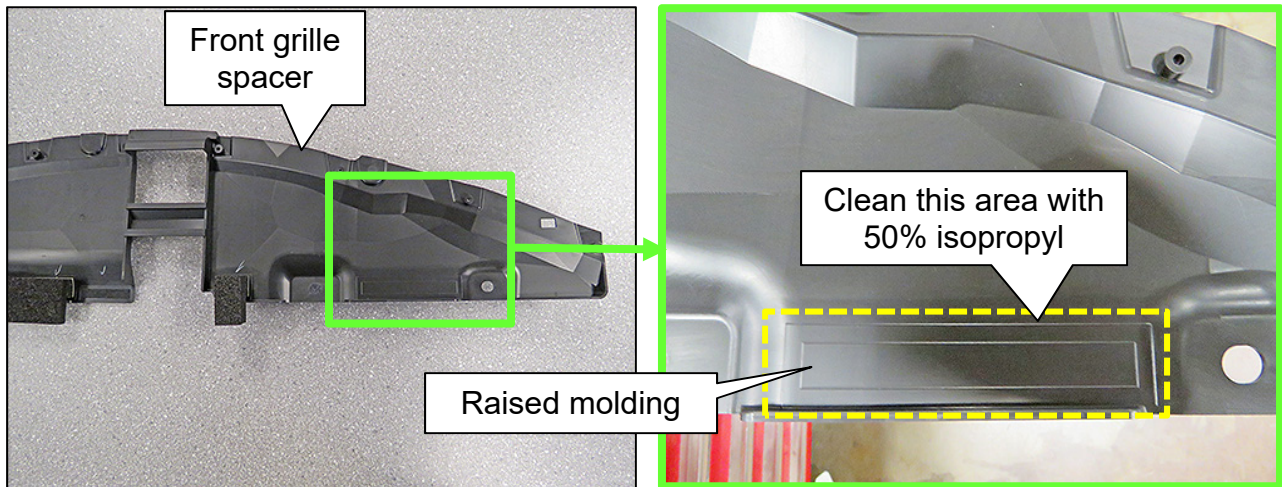



13. Clean the area on the top of the new front grille spacer shown highlighted in Figure 17 with 50% isopropyl alcohol.

14. Attach the LABEL-CAUTION, MOTOR FAN (fan warning label) to the top of the new front grille spacer where shown in Figure 17.

**NOTE:** See the Parts Information for the LABEL-CAUTION, MOTOR FAN (fan warning label).

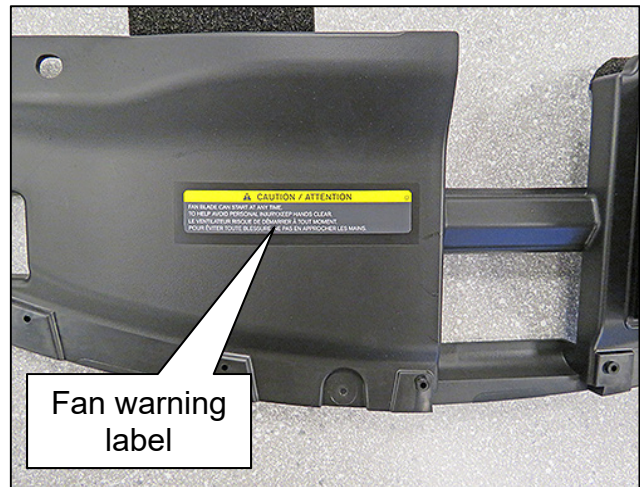

Figure 17

15. Install the new front grille spacer onto the vehicle in the reverse order that the original was removed.

16. If stored, erase DTC P0101.

## PARTS INFORMATION

DESCRIPTION	PART NUMBER	QUANTITY
SEAL 1 (10 x 20 x 116 mm foam block)	21456-6MA1A	1
SEAL 2 (10 x 20 x 70 mm foam block)	21456-6MA1B	1
SEAL-RUBBER (20 x 30 x 40 mm foam block)	16542-6MA0A	2
MOUNTING, RADIATOR GRILLE (Front grille spacer)	62398-6MA0B	1
MOUNTING (20 x 30 x 100 mm foam block)	62398-6MJ0A	1
LABEL-CAUTION, MOTOR FAN (Fan warning label)	21599-7991A	1
AIR CLEANER ELEMENT	16546-4BC2A	1

## CLAIMS INFORMATION

Submit a Primary Part (PP) type line claim using the following claims coding:

DESCRIPTION	PFP	OP CODE	SYM	DIA	FRT
Install Foam and Clear DTC	(1)	DX57AA	ZE	32	0.7(2)

- (1) Refer to the Electronics Part Catalog, and use the Grille Assembly (62310-\*\*\*\*\*) as the Primary Failed Part (PFP).
- (2) FRT allows adequate time to access DTC codes and reprogram ECM. No other diagnostic procedures subsequently required. Do NOT claim any Diagnostic Op Codes with this claim.

## AMENDMENT HISTORY

PUBLISHED DATE	REFERENCE	DESCRIPTION
December 13, 2018	NTB18-084	Original bulletin published