



# Technical Service Bulletin

---

## 19 Coolant level warning light on, coolant marks on coolant pump - 4.0 TFSI

19 17 91 2048936/1 September 20, 2017.

Model(s)	Year	VIN Range	Vehicle-Specific Equipment
S6, RS 6, and S7	2013 - 2018	All	4.0 TFSI
RS 6+, RS 7+	2016 - 2018	All	4.0 TFSI
RS 7	2014 - 2018	All	4.0 TFSI
A8, S8	2013 - 2017	All	4.0 TFSI
S8+	2016 - 2017	All	4.0 TFSI

## Condition

### Customer statement:

- Coolant level warning light on. The vehicle loses or is leaking coolant.



# Technical Service Bulletin

## Workshop findings:

There are coolant marks in the area of the coolant pump housing (Figure 1, position 12), the coolant connector union (Figure 1, position 7) or the thermostat housing (Figure 1, position 14). After cleaning the coolant marks and performing another leakage test there are **fresh** coolant marks on the coolant pump drive (Figure 2 through Figure 6).

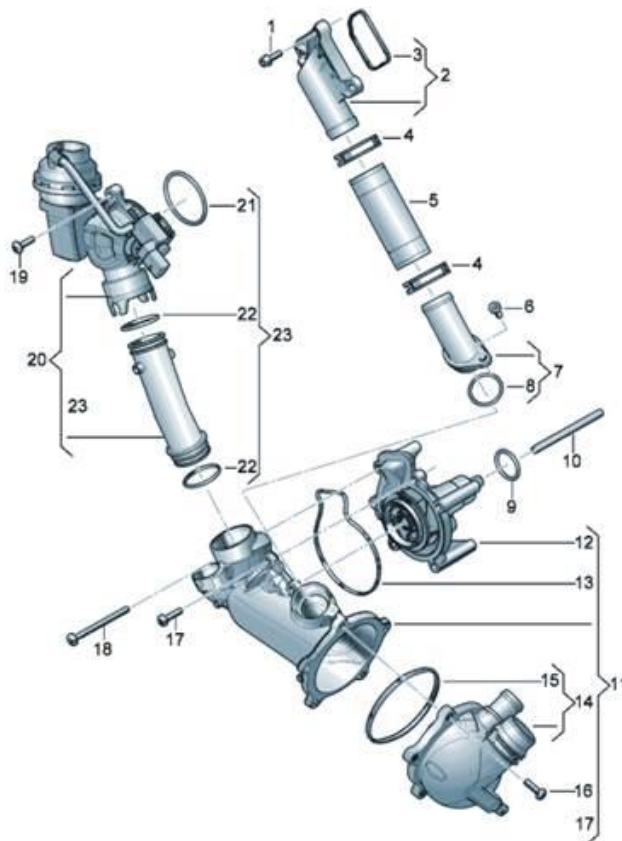

*Figure 1. View position complete water pump assembly (rear view).*



*Figure 2. Coolant marks in plug of coolant pump housing.*



# Technical Service Bulletin

---



**Figure 3.** Coolant marks on flange of coolant pump housing.



**Figure 4.** Coolant marks on flange of thermostat housing.



# Technical Service Bulletin

---



*Figure 5. Coolant marks on coolant connector union.*



*Figure 6. Areas where coolant marks can be found.*

## Technical Background

The coolant pump housing is sealed off with a slip ring seal to the input shaft. To prevent the seal from drying up, a minor coolant leak is necessary to lubricate the seal.

If coolant marks are detected in the area of the coolant pump housing during a service and there is no customer concern about coolant level/loss, a replacement of the coolant pump housing is not allowed.



# Technical Service Bulletin

## Production Solution

Not applicable.

## Service

1. Fully complete the attached worksheet and attach it to the repair order.
2. Remove the coolant marks and bleed the cooling system according to the repair manual. Then check the cooling system for leaks according to the repair manual:
  - If there is no new leak visible on the coolant pump, **do not** perform any further repairs.
3. If a new coolant leak is detected and can be assigned to a component, take a photo of the **renewed** leak and attach it to the repair order.
4. If there is a coolant leak in the area of the coolant connector union a replacement of the O- ring only (Figure 1, position 8) is sufficient.



**Note:**

In the case of insufficiently documented repair orders the warranty claim may be denied.

## Warranty

<b>Claim Type:</b>	<ul style="list-style-type: none"> <li>• 110 up to 48 Months/50,000 Miles.</li> <li>• G10 for CPO Covered Vehicles – Verify Owner.</li> <li>• If vehicle is outside any warranty, this Technical Service Bulletin is informational only.</li> </ul>		
<b>Service Number:</b>	1950 without any parts/replace coolant pump 1961 replace O-ring on coolant connector union		
<b>Damage Code:</b>	0050		
<b>Labor Operations:</b>	<b>All models:</b>		
	Remove + reinstall front dampening pan Must only be used if O-ring is not replaced	1082 1900	40 TU
	Clean coolant pump	1950 2999	10 TU



# Technical Service Bulletin

	Cover (plenum) remove + reinstall	8522 1900	According to ElsaPro
	Bleed cooling system, check for leaks	1938 0799	80 TU
	<b>A8 and S8:</b>		
	Replace O-ring on connector union	1961 5599	160 TU
	<b>S6, S7, and RS 7:</b>		
	Remove + reinstall cooling fan housing	1920 19XX	According to ElsaPro
	Replace O-ring on connector union	1961 55 99	20 TU
<b>Diagnostic Time:</b>	GFF	No allowance	0 TU
	Road test prior to service procedure	No allowance	0 TU
	Road test after service procedure	0121 0004	10 TU
	Technical diagnosis at dealer's discretion (Refer to Section 2.2.1.2 and Audi Warranty Online for DADP allowance details)		
<b>Claim Comment:</b>	As per TSB #2048936/1		

All warranty claims submitted for payment must be in accordance with the *Audi Warranty Policies and Procedures Manual*. Claims are subject to review or audit by Audi Warranty.

## Required Parts and Tools

Part Number	Part Description
VAG1274/8	Adapter
VAG1274/10	Adapter
VAG1274B	Adapter
VAS 6096	Cooling system pressure tester



# Technical Service Bulletin

---

## Additional Information

All parts and service references provided in this TSB (2048936) are subject to change and/or removal. Always check with your Parts Department and service manuals for the latest information.

©2017 Audi of America, Inc. All rights reserved. Information contained in this document is based on the latest information available at the time of printing and is subject to the copyright and other intellectual property rights of Audi of America, Inc., its affiliated companies and its licensors. All rights are reserved to make changes at any time without notice. No part of this document may be reproduced, stored in a retrieval system, or transmitted in any form or by any means, electronic, mechanical, photocopying, recording, or otherwise, nor may these materials be modified or reposted to other sites without the prior expressed written permission of the publisher.