

February 15, 2019

Version 1

**2016-18 Civic 1.5L: Software Update with A/C Control Unit Update;
DTC P0300, P0301, P0302, P0303, P0304, or P0172****AFFECTED VEHICLES**

Year	Model	Trim	VIN Range
2016-18	Civic	ALL with 1.5L Engine	ALL

BACKGROUND

Under certain circumstances, the vehicle may experience driveability issues which may result in DTCs P0300 (random misfire detected), P0301 (No. 1 cylinder misfire detected), P0302 (No. 2 cylinder misfire detected), P0303 (No. 3 cylinder misfire detected), P0304 (No. 4 cylinder misfire detected), or P0172 (fuel system too rich) or a whirling noise coming from the engine compartment.

NOTE

Check the VIN of the vehicle to see if 18-137 applies. If it applies, go to 18-137 and perform the procedure. If it has already been completed and misfire DTCs are set, go to SPARK PLUG INSPECTION PROCEDURE.

POSSIBLE CAUSE

There is a problem with the ECU software.

CORRECTIVE ACTION

If 18-137 applies, perform that affected bulletin first. If 18-137 does not apply and misfire or fuel system too rich DTCs are set, do REPAIR PROCEDURE A. If there is a whirling noise coming from the engine compartment, do REPAIR PROCEDURE B.

In some cases, misfire DTCs may return. If that happens, go to SPARK PLUG INSPECTION PROCEDURE.

CUSTOMER INFORMATION:The information in this bulletin is intended for use only by skilled technicians who have the proper tools, equipment, and training to correctly and safely maintain your vehicle. These procedures should not be attempted by "do-it-yourselfers," and you should not assume this bulletin applies to your vehicle, or that your vehicle has the condition described. To determine whether this information applies, contact an authorized Honda automobile dealer.

WARRANTY CLAIM INFORMATION

The normal warranty applies.

NOTES

- **DTC is required with claim submission.**
- **Since the templates below do not include oil, Non-Bulk oil and Bulk oil dealers must add the correct information into the Required Material section of your claim.**

Operation Number	Description	Flat Rate Time	Defect Code	Symptom Code	Template ID	Failed Part Number
1245A7	Reset the maintenance minder. Update the PGM-FI and TCU software. Replace the oil and do a throttle position reset and PCM idle learn procedure (A/C control unit replacement not necessary) .	0.6 hr	03214	09107	A19012A	37805-5PA-A85

Operation Number	Description	Flat Rate Time	Defect Code	Symptom Code	Template ID	Failed Part Number
1245A6	Reset the maintenance minder. Update the PGM-FI and TCU software. Replace the oil and do a throttle position reset and PCM idle learn procedure. Replace the A/C control unit (Dual Zone) .	0.8 hr	03214	09107	A19012B	37805-5PA-A85

Operation Number	Description	Flat Rate Time	Defect Code	Symptom Code	Template ID	Failed Part Number
1245A6	Reset the maintenance minder. Update the PGM-FI and TCU software. Replace the oil and do a throttle position reset and PCM idle learn procedure. Replace the A/C control unit (Non Dual Zone) .	0.8 hr	03214	09107	A19012C	37805-5PA-A85

NOTE

Use the following template if the **spark plugs** were replaced.

Since the templates below do not include oil, Non-Bulk oil and Bulk oil dealers must add the correct information into the Required Material section of your claim.

Operation Number	Description	Flat Rate Time	Defect Code	Symptom Code	Template ID	Failed Part Number
1245A6	Reset the maintenance minder. Update the PGM-FI and TCU software. Replace the oil and do a throttle position reset and the PCM idle learn procedure. Replace the A/C control unit (Dual Zone).	0.8 hr	03214	09107	A19012D	37805-5PA-A85
A	Spark plugs (All except Si)(inspection or replacement).	0.2 hr				

Operation Number	Description	Flat Rate Time	Defect Code	Symptom Code	Template ID	Failed Part Number
1245A6	Reset the maintenance minder. Update the PGM-FI and TCU software. Replace the oil and do a throttle position reset and the PCM idle learn procedure. Replace the A/C control unit (Dual Zone).	0.8 hr	03214	09107	A19012E	37805-5PA-A85
A	Spark plugs (Si only) (inspection or replacement).	0.2 hr				

Since the templates below do not include oil, Non-Bulk oil and Bulk oil dealers must add the correct information into the Required Material section of your claim.

Operation Number	Description	Flat Rate Time	Defect Code	Symptom Code	Template ID	Failed Part Number
1245A6	Reset the maintenance minder. Update the PGM-FI and TCU software. Replace the oil and do a throttle position reset and PCM idle learn procedure. Replace the A/C control unit (Non Dual Zone).	0.8 hr	03214	09107	A19012F	37805-5PA-A85
A	Spark plugs (inspection or replacement).	0.2 hr				

Operation Number	Description	Flat Rate Time	Defect Code	Symptom Code	Template ID	Failed Part Number
1245A7	Reset the maintenance minder. Update the PGM-FI and TCU software. Replace the oil and do a throttle position reset and PCM idle learn procedure. (A/C control unit replacement not necessary).	0.6 hr	03214	09107	A19012G	37805-5PA-A85
A	Spark plugs (inspection or replacement).	0.2 hr				

Operation Number	Description	Flat Rate Time	Defect Code	Symptom Code	Template ID	Failed Part Number
117160	Spark plugs (All except Si). (Inspection only) (Admin Included)	0.3 hr	03214	09107	A19012H	12290-5PA-A01

Operation Number	Description	Flat Rate Time	Defect Code	Symptom Code	Template ID	Failed Part Number
117160	Spark plugs (Si only). (Inspection only) (Admin Included)	0.3 hr	03214	09107	A19012I	12290-5PA-A01

Operation Number	Description	Flat Rate Time	Defect Code	Symptom Code	Template ID	Failed Part Number
117160	Spark plugs (All except Si). (Inspect and replace) (Admin Included)	0.3 hr	03214	09107	A19012J	12290-5PA-A01

Operation Number	Description	Flat Rate Time	Defect Code	Symptom Code	Template ID	Failed Part Number
117160	Spark plugs (Si only). (Inspect and replace) (Admin Included)	0.3 hr	03214	09107	A19012K	12290-5PA-A01

NOTE

Use the following template if the **camshafts** were only inspected.

Operation Number	Description	Flat Rate Time	Defect Code	Symptom Code	Template ID	Failed Part Number
1105C0	Remove valve cover and inspect camshafts. (No replacement required.)	0.7 hr	03214	09107	A19012L	37805-5PA-A85

NOTE

Use the following template if the **camshafts** and **rocker arm assembly** were replaced.

Since the templates below do not include oil, Non-Bulk oil and Bulk oil dealers must add the correct information into the Required Material section of your claim.

Civic (2-Door, 4-Door) (All Except Si)

Operation Number	Description	Flat Rate Time	Defect Code	Symptom Code	Template ID	Failed Part Number
1105C0	Remove valve cover and inspect camshafts.	0.7 hr	03214	09107	A19012M	37805-5PA-A85
A	Replace camshafts and rocker arm assembly. (Pre-approval needed, see iN parts catalog for ordering.)	4.9 hr				

Civic Si (2-Door, 4-Door)

Operation Number	Description	Flat Rate Time	Defect Code	Symptom Code	Template ID	Failed Part Number
1105C0	Remove valve cover and inspect camshafts.	0.7 hr	03214	09107	A19012N	37805-5PA-A85
A	Replace camshafts and rocker arm assembly. (Pre-approval needed, see iN parts catalog for ordering.)	4.9 hr				

Civic Hatchback (5-Door)

Operation Number	Description	Flat Rate Time	Defect Code	Symptom Code	Template ID	Failed Part Number
1105C0	Remove valve cover and inspect camshafts.	0.7 hr	03214	09107	A19012O	37805-5PA-A85
A	Replace camshafts and rocker arm assembly. (Pre-approval needed, see iN parts catalog for ordering.)	4.9 hr				

Skill Level: Repair Technician

PARTS INFORMATION

Part Name	Part Number	Quantity
Auto Air Conditioner CPU Assembly (A/C control unit) (Non-Dual Zone Automatic Climate Control)	79610-TBA-A51	1
Auto Air Conditioner CPU Assembly (A/C control unit) (Dual-Zone Automatic Climate Control)	79610-TBC-A51	1

NOTE

These parts are needed if replacing the **spark plugs**.

Part Name	Part Number	Quantity
Spark Plug (All except Si)	12290-59B-003	4
Spark Plug (Si only)	12290-5PA-A01	4

REQUIRED MATERIAL

NOTE

For **Non-Bulk oil** and **Bulk oil dealers**, add the correct information into the **Required Material** section of your claim.

Part Name	Part Number	Quantity
0W-20 (Non-Bulk Oil Participants) (quarts)	08798-9063	4
0W-20 (Bulk Oil Participants) (gallons)	FS020-BAS-N0L	1

SOFTWARE INFORMATION

NOTE

Unnecessary or incorrect repairs resulting from a failure to update the i-HDS are not covered under warranty.

i-HDS Software Version: **1.004.060 or later**

J2534 Software Information:

- PC Application Version **1.1.0.6 or later**
- Database update **27-DEC-2018 or later**

Before beginning the repair, make sure that both the i-HDS and J2534 software are updated as listed above.

Do only the update listed in this service bulletin.

To update the software, you must use the MVCI or the DST-i interface in conjunction with the J2534 Rewrite PC application on the i-HDS.

For more information about updating the i-HDS, the MVCI, and vehicle systems, refer to service bulletin 01-023, *Updating Control Units/Modules*.

Year/Model	Emission Code	Software System	Program ID (or later)	Program P/N (or later)
2016 Civic (EX with CVT 2-Door, 4-Door)	KA	PGM-FI	AAA580	37805-5AA-A58
		TCU	CGA080	28101-5CG-A08
2016 Civic (Touring with CVT 2-Door, 4-Door)	KA	PGM-FI	AAA680	37805-5AA-A68
		TCU	CGA080	28101-5CG-A08
2016 Civic (EX with CVT 2-Door, 4-Door)	KL	PGM-FI	AAL590	37805-5AA-L59
		TCU	CGA080	28101-5CG-A08
2016 Civic (Touring with CVT 2-Door, 4-Door)	KL	PGM-FI	AAL690	37805-5AA-L69
		TCU	CGA080	28101-5CG-A08
2017 Civic (EX with M/T 2-Door, 4-Door)	KA	PGM-FI	AAA070	37805-5AA-A07
2017 Civic (EX with CVT 2-Door, 4-Door)	KA	PGM-FI	AAA580	37805-5AA-A58
		TCU	CGA080	28101-5CG-A08
2017 Civic (EX with CVT 2-Door, 4-Door)	KL	PGM-FI	AAL590	37805-5AA-L59
		TCU	CGA080	28101-5CG-A08
2017 Civic (Touring with CVT 2-Door, 4-Door)	KA	PGM-FI	AAA680	37805-5AA-A68
		TCU	CGA080	28101-5CG-A08
2017 Civic (Touring with CVT 2-Door, 4-Door)	KL	PGM-FI	AAL690	37805-5AA-L69
		TCU	CGA080	28101-5CG-A08
2017 Civic (Si 2-Door, 4-Door)	KA	PGM-FI	AMA050	37805-5AM-A05
2017 Civic (LX with M/T 5-Door)	KA	PGM-FI	ANA040	37805-5AN-A04

Year/Model	Emission Code	Software System	Program ID (or later)	Program P/N (or later)
2017 Civic (LX with CVT 5-Door)	KA	PGM-FI	ANA540	37805-5AN-A54
		TCU	CKA040	28101-5CK-A04
2017 Civic (LX w/Honda Sensing 5-Door)	KA	PGM-FI	ANA750	37805-5AN-A75
		TCU	CKA150	28101-5CK-A15
2017 Civic (LX with CVT 5-Door)	KL	PGM-FI	ANL540	37805-5AN-L54
		TCU	CKA040	28101-5CK-A04
2017 Civic (EX, EX-L 5-Door)	KL	PGM-FI	AN9540	37805-5AN-954
		TCU	CKA040	28101-5CK-A04
2017 Civic (EX, EX-L 5-Door)	KA	PGM-FI	ANB540	37805-5AN-B54
		TCU	CKA040	28101-5CK-A04
2017 Civic (Sport with M/T 5-Door)	KA	PGM-FI	ANA150	37805-5AN-A15
2017 Civic (Sport with CVT 5-Door)	KA	PGM-FI	ANA640	37805-5AN-A64
		TCU	CKC040	28101-5CK-C04
2017 Civic (Sport with CVT 5-Door)	KL	PGM-FI	ANL640	37805-5AN-L64
		TCU	CKC040	28101-5CK-C04
2017 Civic (Sport Touring 5-Door)	KA	PGM-FI	ANA850	37805-5AN-A85
		TCU	CKC150	28101-5CK-C15
2018 Civic (Si 2-Door, 4-Door)	KA	PGM-FI	AMA050	37805-5AM-A05
2018 Civic (EX 2-Door) (EX-T 4-Door) (M/T)	KA	PGM-FI	AAA110	37805-5AA-A11
2018 Civic (EX 2-Door) (EX-T 4-Door)	KA	PGM-FI	AAA720	37805-5AA-A72
		TCU	GCA820	28101-5GC-A82
2018 Civic (EX 2-Door) (EX-T 4-Door)	KL	PGM-FI	AAL720	37805-5AA-L72
		TCU	GCA820	28101-5GC-A82
2018 Civic (Touring 2-Door) (EX-T w/ Honda Sensing 4-Door)	KA	PGM-FI	AAA820	37805-5AA-A82
		TCU	GCA820	28101-5GC-A82
2018 Civic (Touring 2-Door) (EX-T w/ Honda Sensing 4-Door)	KL	PGM-FI	AAL820	37805-5AA-L82
		TCU	GCA820	28101-5GC-A82
2018 Civic (EX-A with CVT 4-Door)	KA	PGM-FI	BAA510	37805-5BA-A51
		TCU	GCA820	28101-5GC-A82

Year/Model	Emission Code	Software System	Program ID (or later)	Program P/N (or later)
2018 Civic (EX-A with CVT 4-Door)	KL	PGM-FI	BAL410	37805-5BA-L41
		TCU	GCA820	28101-5GC-A82
2018 Civic (EX w/ Honda Sensing with CVT 4-Door)	KA	PGM-FI	AJA620	37805-5AJ-A62
		TCU	GCA820	28101-5GC-A82
2018 Civic (EX w/ Honda Sensing with CVT 4-Door)	KL	PGM-FI	AJL620	37805-5AJ-L62
		TCU	GCA820	28101-5GC-A82
2018 Civic (EX Navigation with CVT 4-Door)	KA	PGM-FI	AJA520	37805-5AJ-A52
		TCU	GCA820	28101-5GC-A82
2018 Civic (EX Navigation with CVT 4-Door)	KL	PGM-FI	AJL520	37805-5AJ-L52
		TCU	GCA820	28101-5GC-A82
2018 Civic (LX with M/T 5-Door)	KA	PGM-FI	ANA040	37805-5AN-A04
2018 Civic (LX with CVT 5-Door)	KA	PGM-FI	ANA540	37805-5AN-A54
		TCU	CKA040	28101-5CK-A04
2018 Civic (LX with CVT 5-Door)	KL	PGM-FI	ANL540	37805-5AN-L54
		TCU	CKA040	28101-5CK-A04
2018 Civic (LX w/ Honda Sensing 5-Door)	KA	PGM-FI	ANA750	37805-5AN-A75
		TCU	CKA150	28101-5CK-A15
2018 Civic (LX w/ Honda Sensing 5-Door)	KL	PGM-FI	ANL750	37805-5AN-L75
		TCU	CKA150	28101-5CK-A15
2018 Civic (EX, EX-L 5-Door)	KA	PGM-FI	AN9540	37805-5AN-954
		TCU	CKA040	28101-5CK-A04
2018 Civic (EX, EX-L 5-Door)	KL	PGM-FI	ANB540	37805-5AN-B54
		TCU	CKA040	28101-5CK-A04
2018 Civic (EX w/ Honda Sensing 5-Door)	KA	PGM-FI	ANA950	37805-5AN-A95
		TCU	CKA150	28101-5CK-A15
2018 Civic (EX w/ Honda Sensing 5-Door)	KL	PGM-FI	ANL950	37805-5AN-L95
		TCU	CKA150	28101-5CK-A15
2018 Civic (Sport with M/T 5-Door)	KA	PGM-FI	ANA150	37805-5AN-A15
2018 Civic (Sport with CVT 5-Door)	KA	PGM-FI	ANA640	37805-5AN-A64
		TCU	CKC040	28101-5CK-C04

Year/Model	Emission Code	Software System	Program ID (or later)	Program P/N (or later)
2018 Civic (Sport with CVT 5-Door)	KL	PGM-FI	ANL640	37805-5AN-L64
		TCU	CKC040	28101-5CK-C04
2018 Civic (Sport Touring with CVT 5-Door)	KA	PGM-FI	ANA850	37805-5AN-A95
		TCU	CKC150	28101-5CK-C15
2018 Civic (Sport Touring with CVT 5-Door)	KL	PGM-FI	ANL850	37805-5AN-L85
		TCU	CKC150	28101-5CK-C15

REPAIR PROCEDURE A

If misfire or fuel system too rich DTCs are set, follow the procedure below.

1. Reset maintenance minder main code A. Refer to the service information.
2. Drain and refill the engine oil. Do not replace the oil filter. (3.4 quarts)
3. Connect the i-HDS and click on the **Body Electrical**. From there, select **HVAC** and open **Data List/Snapshot** to check if the A/C control unit has been replaced. One of three options will appear; **Not Complete**, **Completed**, or **Not Applicable**.
 - If it reads **Completed** or **Not Applicable**, skip to step 5.
 - If it reads **Not Complete**, go to step 4.
4. Replace the climate control unit.
 - 4.1. Remove the climate control unit and replace with the new unit. See service information for additional instructions.
 - 4.2. Install all parts in reverse order.
 - 4.3. Run the self-diagnostics procedure with the i-HDS to make sure there are no problems in the system.
5. With the i-HDS, check to see if the PGM-FI and TCU software has been updated by using the J2534 rewrite application.
 - If they are up to date, the procedure is complete.
 - If not, go to step 6.
6. Update the PGM-FI and TCM software using the i-HDS J2534 rewrite software with the MVCI or DST-i. Refer to Service Bulletin 01-023, *Updating Control Units/Modules*.
7. Reset the throttle position learned values by referencing the throttle body removal and installation in the service information, then do the PCM idle learn procedure. Refer to service information for additional instructions.

NOTE

For more information on the PCM idle learn procedure, see the *Tech2Tech®* video, "A Look at PCM Idle Learn".

SPARK PLUG INSPECTION PROCEDURE

1. In some cases, the DTCs may return. If this happens, inspect the spark plugs.



- If the spark plugs are OK, the procedure is complete. Continue with normal troubleshooting.
 - If the spark plugs are fouled, go to step 2.
2. Replace the spark plugs per service information and check for stored DTCs.

NOTE

Make sure to write down the stored DTCs on the R.O.

- If the applicable DTCs do not return, the procedure is complete.
- If the applicable DTCs return, this bulletin does not apply. Continue with normal troubleshooting.

REPAIR PROCEDURE B

If there is a whirling noise coming from the engine, follow the procedure below.

1. Warm up the engine by increasing the engine speed to **3,000 rpm** for two fan cycles.
2. After the warm-up procedure is completed, let the car return to idle for **10 seconds**.
3. After **10 seconds**, slowly increase the engine speed up to **3500 rpm** (this should take at least **20 seconds**).
4. Once the engine speed reaches **3500 rpm**, release the accelerator pedal and let the engine speed return to idle.
5. With the hood closed and inside the cabin, compare the audio file [here](#) to the noise heard.
 - If the noise is similar, continue to step 6.
 - If the noise is not similar, this bulletin does not apply. Continue with normal system troubleshooting.
6. Remove the cylinder head cover. See service information for additional instructions.

7. Compare the appearance of the camshaft lobes to the photo below.

 GOOD



 NO GOOD

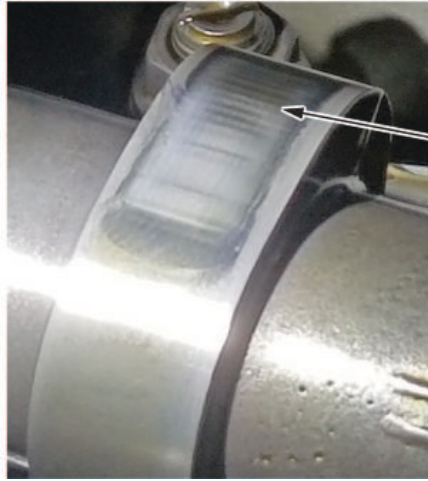

The cam surface has ridges and a "cloudy" appearance.

- If the camshafts appear similar to the no good photo, go to step 8.
 - If the camshafts appear similar to the good photo, this bulletin does not apply. Continue with normal system troubleshooting.
8. Take a photo of the cam lobe, then follow the directions in the parts catalog when ordering the necessary parts.

The following instructions are for replacement of the intake and exhaust camshafts and all rocker arm assemblies. This is only if you have been approved by following the instructions in the parts catalog.

1. Relieve the fuel pressure and remove the high pressure fuel pump. Refer to the service information for additional instructions.
2. Set the crankshaft to top dead center (TDC) for No. 1 cylinder. Refer to step 4 of the Camshaft Timing Inspection in the service information.
3. Mark the timing chain at the punch marks on the exhaust and intake camshaft sprocket and VTC actuator as seen below.

Mark the cam chain at the punch marks on the sprocket.

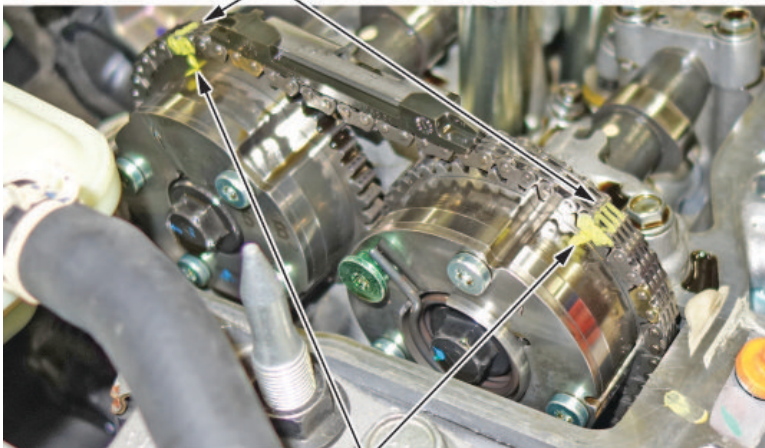

PUNCH MARKS

4. Raise the vehicle on a lift.
5. Remove the right front wheel and the engine undercover.
6. Remove the cam chain auto-tensioner (chain case) cover.
7. Slightly rotate the crankshaft counterclockwise to compress the auto-tensioner. Line up the hole in the lock and auto-tensioner, then insert a 1.2 mm diameter lock pin.

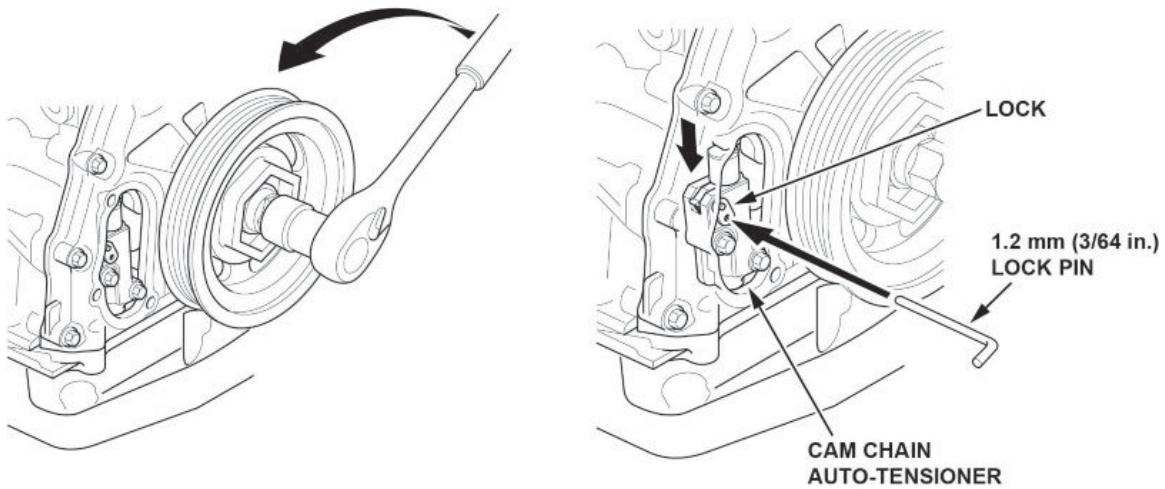

8. Rotate the crankshaft clockwise back to TDC on the No. 1 cylinder to secure the lock pin in place.

9. Remove the camshaft chain auto-tensioner with the lock pin inserted.

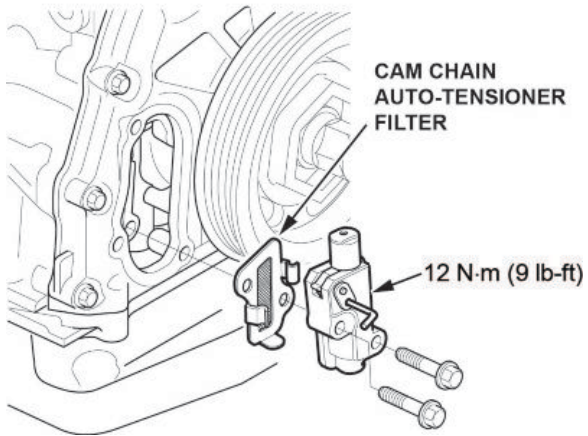

10. Lower the vehicle.

11. Loosen the locknuts and adjusting screws.

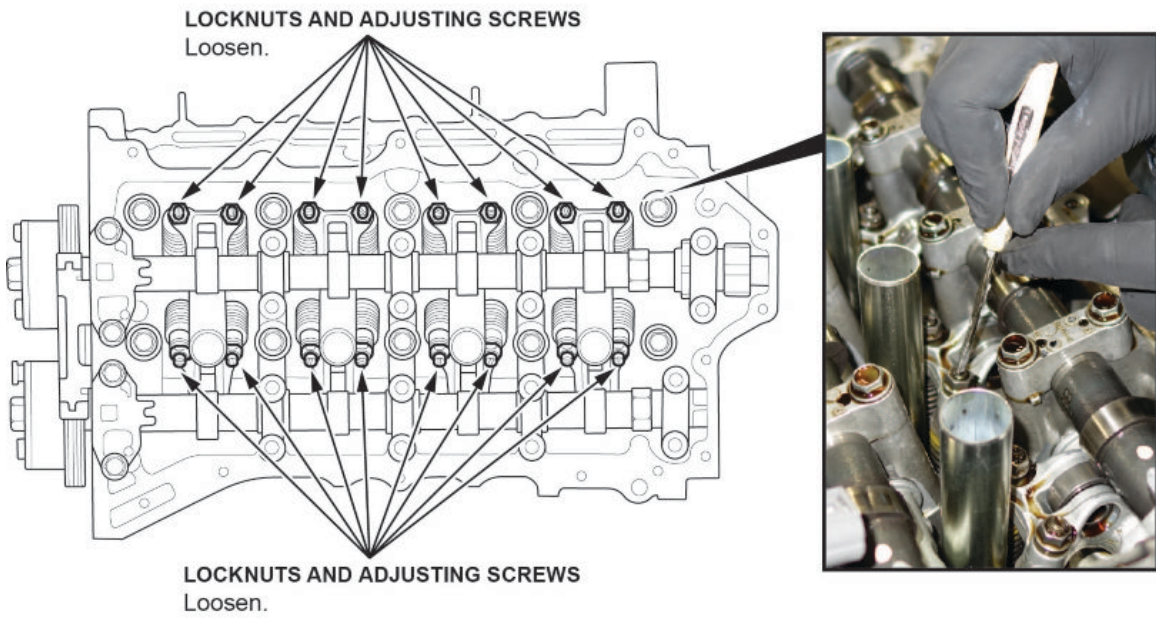

12. Remove the high pressure fuel pump base.

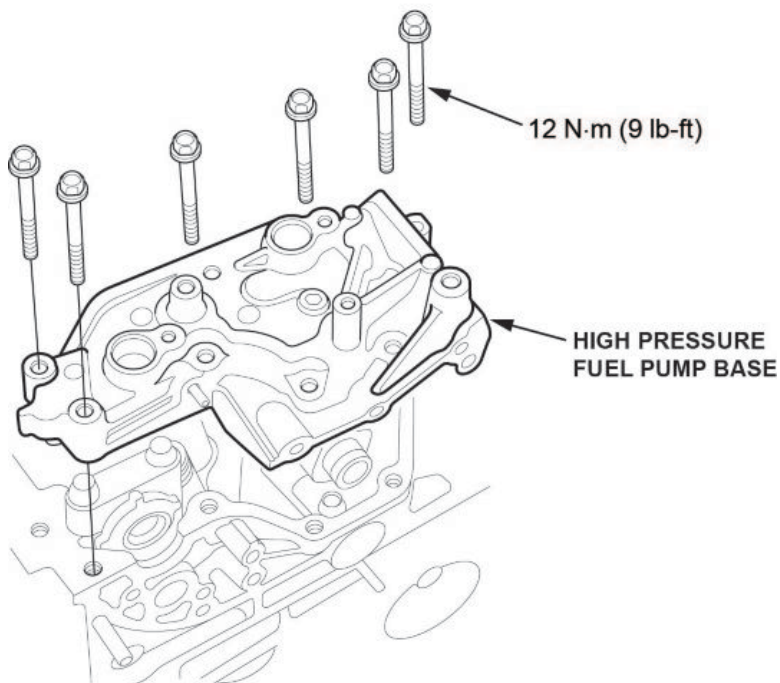

13. Remove the camshaft holder bolts, then remove the camshaft holders. To prevent damaging the camshafts, loosen the bolts in sequence, two turns at a time.

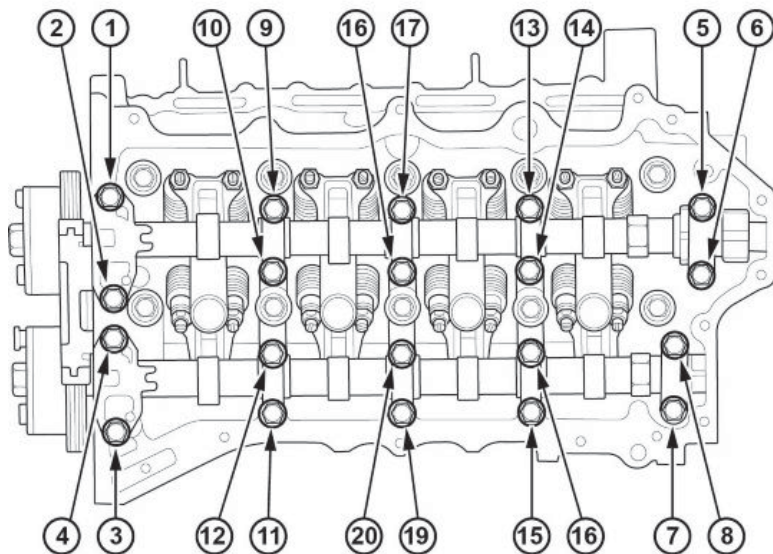

14. Lift up the cam chain, then carefully remove the intake camshaft followed by the exhaust camshaft. You must maintain tension on the cam chain while you do this.

Lift up the cam chain and carefully slip the camshaft out.

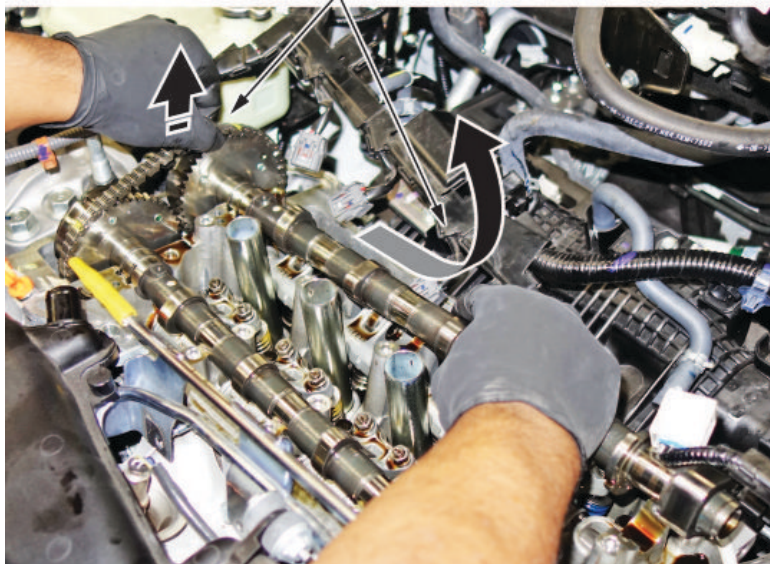

15. Use a bungee cord to hold tension on the cam chain while you are replacing the camshafts.

BUNGEE CORD



BUNGEE HOOK

CAM CHAIN

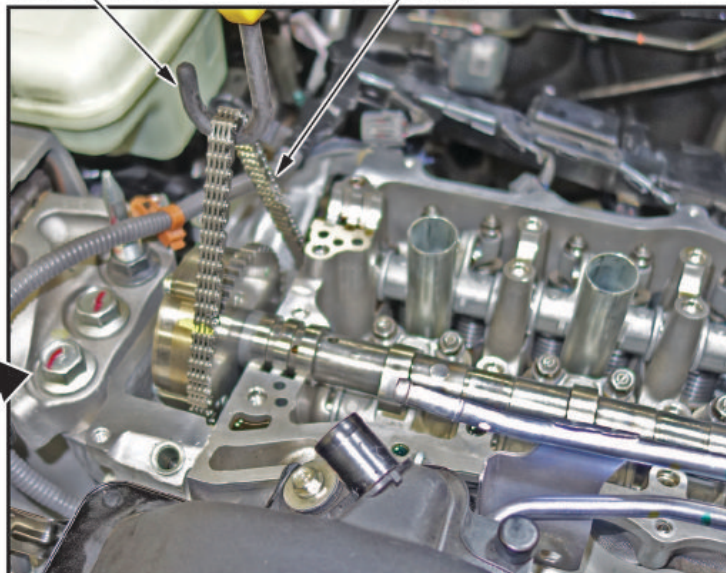

16. When removing the camshaft holders, cam chain guide, and intake and exhaust camshaft, make sure to place them in order of installation on a clean, padded workbench.

17. Remove the rocker arm assembly, and install the new set. Refer to the service information for additional instructions.

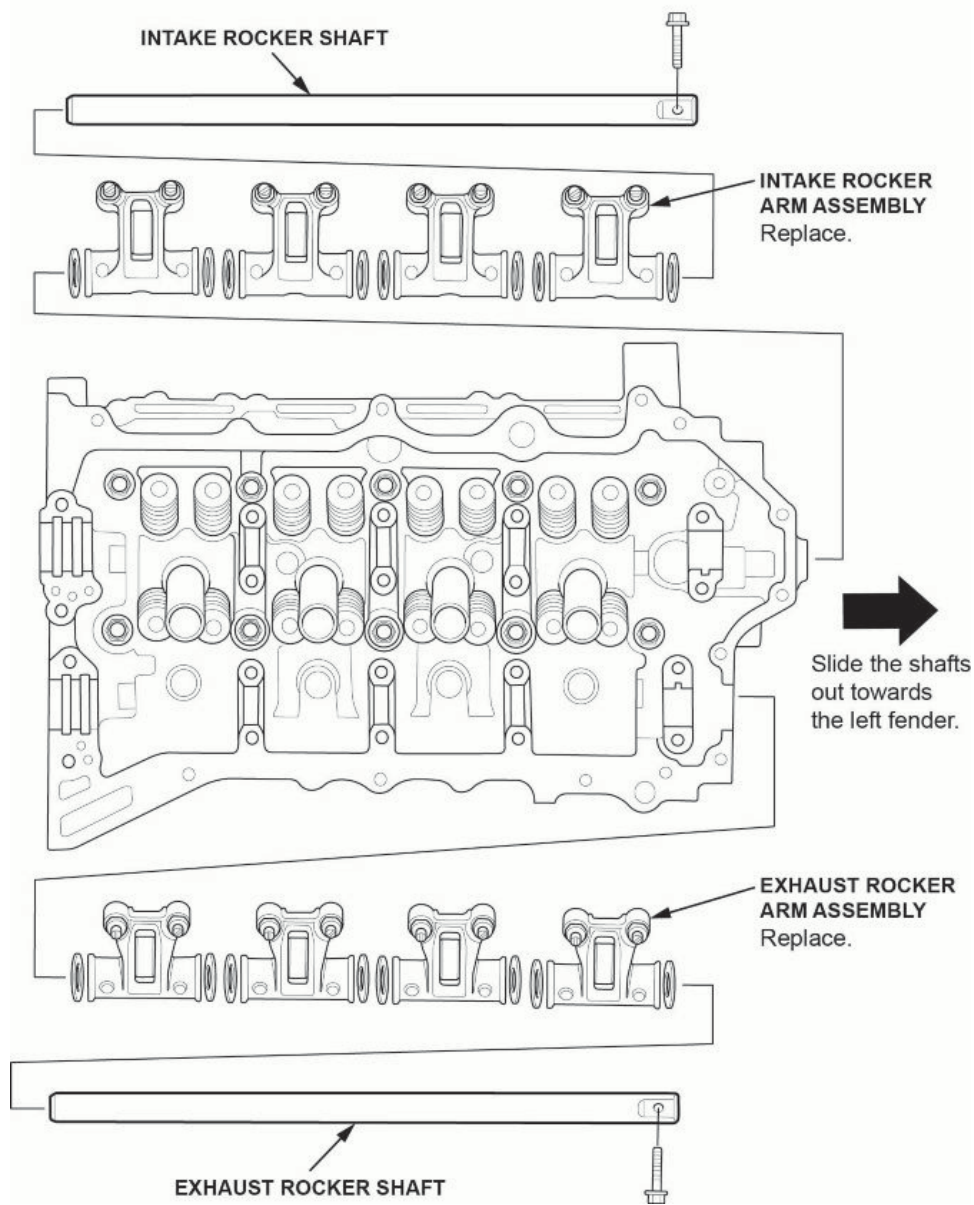

18. With the camshafts out of the engine, hold them with an open-end wrench and loosen the VTC actuator mounting bolts on both camshafts.
19. Install the VTC actuators on the new camshafts.

NOTE

You may need an assistant to help you with this procedure.

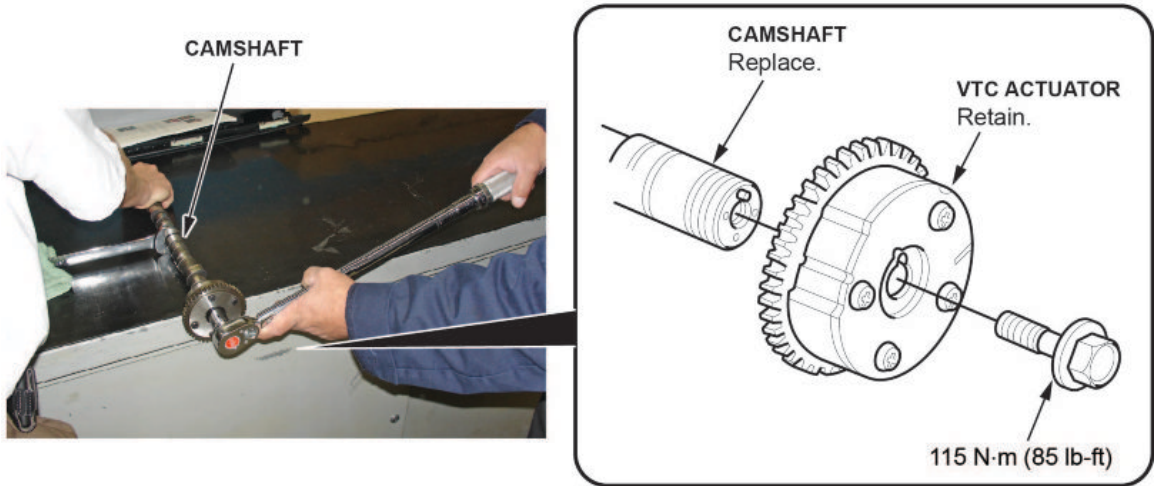

20. Apply fresh engine oil to the new camshafts, and install.

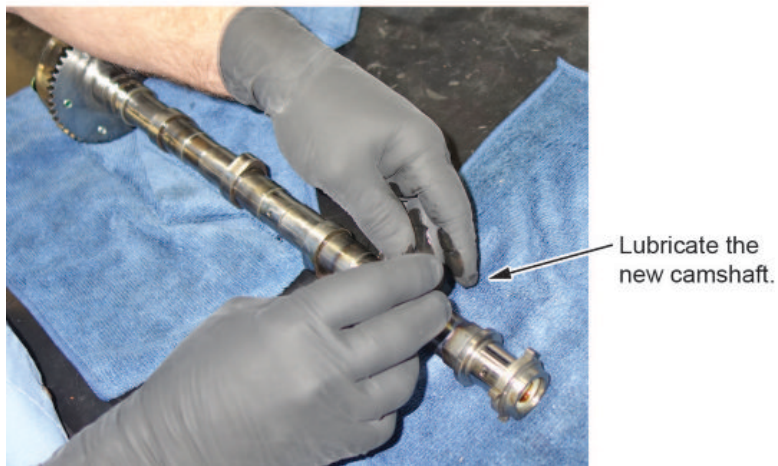

21. When installing the new camshafts, ensure the previously made marks on the VTC actuator and cam chain line up.



As the camshaft is installed, line up the marks made in step 3.

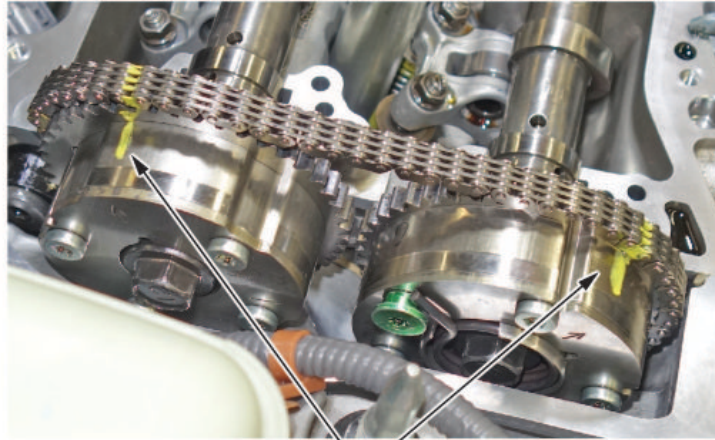

MARKS

22. Install the camshaft holders and the cam chain guide, then torque them to specification.

23. Install the camshaft chain tensioner and release the lock pin.

24. Install the new cam chain auto-tensioner (chain case) cover.

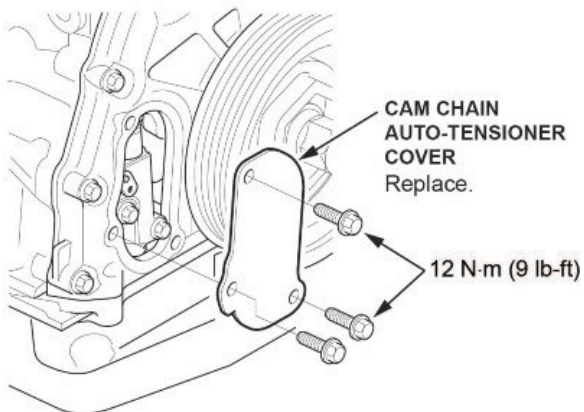

25. To check the camshaft timing, rotate the crankshaft in the direction of engine rotation (clockwise) two full turns, then stop at the TDC mark. Refer to step 4 of the Camshaft Timing Inspection in the service information.

26. Do a valve adjustment.

27. Install the high pressure fuel pump base and new camshaft holder cover. Refer to step 6 of the installation section of the Camshaft and VTC Actuator Removal, Installation, and Inspection (1.5L Engine) in the service information.

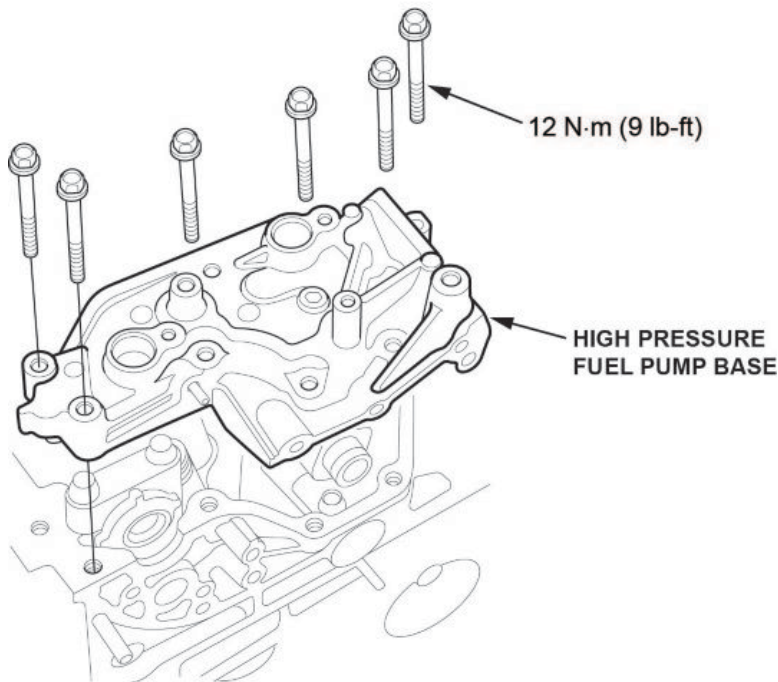

28. Install the cylinder head cover. Refer to the service information for additional instructions.
29. Install the high pressure fuel pump with the new o-ring and fuel joint pipe. Refer to the service information for additional information.
30. Install the engine undercover and any other remaining parts.
31. During the first start up, check for DTCs set or abnormal noises. Refer to service information for additional instructions.
32. Connect the i-HDS and click on the **Body Electrical**. From there, select **HVAC** and open **Data List/Snapshot** to check if the A/C control unit has been replaced. One of three options will appear; **Not Complete**, **Completed**, or **Not Applicable**.
- If it reads **Completed** or **Not Applicable**, skip to step 34.
 - If it reads **Not Complete**, go to step 33.
33. Replace the climate control unit.
- 33.1. Remove the climate control unit and replace with the new unit. See service information for additional instructions.
- 33.2. Install all parts in reverse order.
- 33.3. Run the self-diagnostics procedure with the i-HDS to make sure there are no problems in the system.
34. Reset maintenance minder main code A. Refer to the service information.
35. Drain and refill the engine oil. Do not replace the oil filter. (3.4 quarts)
36. With the i-HDS, check to see if the PGM-FI and TCU software has been updated by using the J2534 rewrite application.
- If not, continue with the procedure.
 - If updated, skip to step 38.
37. Update the PGM-FI and TCM software using the i-HDS J2534 rewrite software with the MVCI or DST-i. Refer to Service Bulletin 01-023, *Updating Control Units/Modules*.

38. Reset the throttle position learned values by referencing the throttle body removal and installation in the service information, then do the PCM idle learn procedure. Refer to service information for additional instructions.

NOTE

For more information on the PCM idle learn procedure, see the *Tech2Tech*[®] video, "A Look at PCM Idle Learn".

END