

PREVOST

Instruction Sheet

IS-19911B

INTELLIGENT SLEEP MODE INSTALLATION

H SERIES COACHES FROM G-3129 UP TO J-0184 WITH PRIME

Revision: B

Added Prime prerequisite. Removed RJB wiring steps.

02-04-2019

MATERIAL

H-series coaches, order kit IS19911 which contains:

Part No.	Description	Qty
062305	HARNESS_ISM_H	1
5001245	SCR TC HEXW Z050 12-24 X 1/2	3
5001341	WSH FL SS 8.4X17X1.6 (M8,5/16)	2
5001787	NUT HEX NYRT SS M8-1.25X9.5	2
506004	RUB AD1 CC POL 3/8" X 1/2" X 20'	2 in
560493	RELAY, LATCHING 24V BDS-A	1
560529	BASE, RELAY	1
560538	COVER, RELAY	2
560539	SCREW, M8, RELAY	2
563158	SHRINK TUBING, DOUBLE WALL / .300" - .060"	3 in
562935	BUTT SPLICE / 22-18 / RED	2
IS-19911	Instruction Sheet	1
FI-19911	Feuille d'instructions	1

NOTE

Material can be obtained through regular channels.

DESCRIPTION

Use this instruction sheet to add ISM to your vehicle.

PREREQUISITE: Coach must have PRIME hardware installed.

This can be confirmed visually by looking for the current sensors and smart equalizer in the main power compartment. Refer to Figure 1 & Figure 2. The smart equalizer has a data connector in addition to the usual battery power connections. Also confirm the SOC% is present in the DID gages menu. (Figure 3)

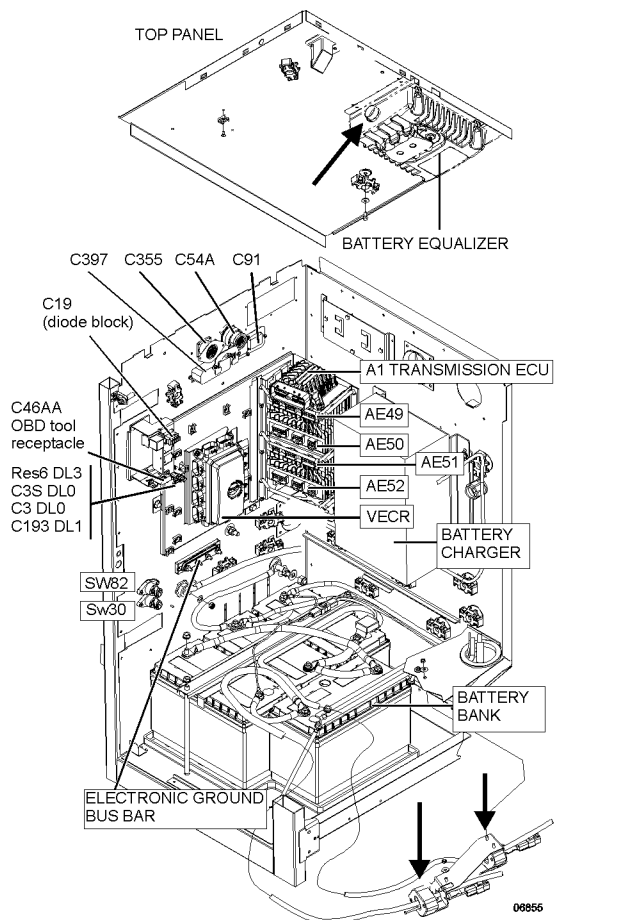

FIGURE 1: EQUALIZER DATA CONNECTION, 12 & 24V CURRENT SENSORS

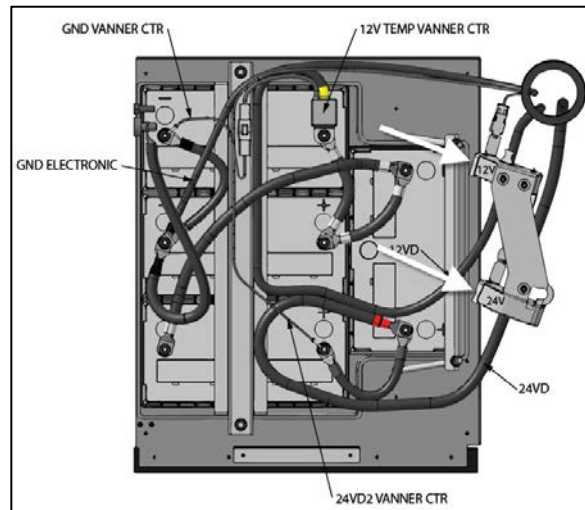

FIGURE 2: 12V & 24V CURRENT SENSORS

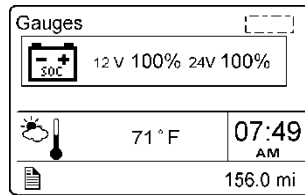

FIGURE 3: BATTERY SOC

TOOLS

- Laptop with VPG** software.
- Serial interface cable or USB to serial adapter (may be required on some laptops)
- C18 Amp Mate-N-Lok pin extractor **682257** (Amp 31885-1)

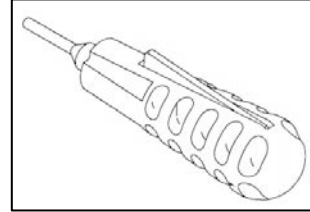

FIGURE 4:682257

- C71 Amp CPC pin extractor **681598** (Amp 305183 R)



FIGURE 5:681598

- VECF / VECR pin extractor: **682256** (Packard 12094429)



FIGURE 6:682256

- A36 (MCM) pin extractor: **683766**

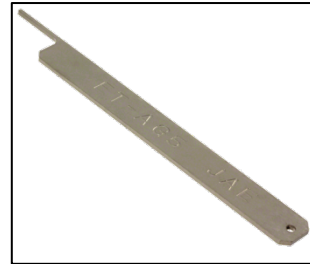

FIGURE 7: 683766

**** Contact Prevest Service Manager or Prevest Service Center to perform the update**

PROCEDURE



DANGER

Park vehicle safely, apply parking brake, stop engine.

ABOUT INTELLIGENT SLEEP MODE (ISM)

ISM is a battery-saving mode designed to limit battery discharge. The ISM will automatically change the vehicle electrical system from normal functional state to sleep mode if the battery SOC falls below 65% (12.2V / 24.4V).

Once the vehicle has entered into sleep mode, the only actions needed to put the vehicle back into its normal functional state are:

- Cycle the ignition key from OFF to ON;
- or
- Open the entrance door;
- or
- Turn on the hazard lights.

ISM forces the vehicle to go into sleep mode if all the following conditions are met:

1. The engine is not running;
2. The parking brake is applied
3. The ignition switch is at the ON, ACC positions or at the OFF position but the 15 minutes “wake up” period after engine shutdown is not expired.
4. The battery state of charge of 12V or 24V system falls below 65%.

PROGRAMMING WITH VPG

Programming must be completed before any wiring modification.

1. Connect the laptop to the vehicle with the serial cable.
2. In VPG, Click on *Vehicle Parameters*

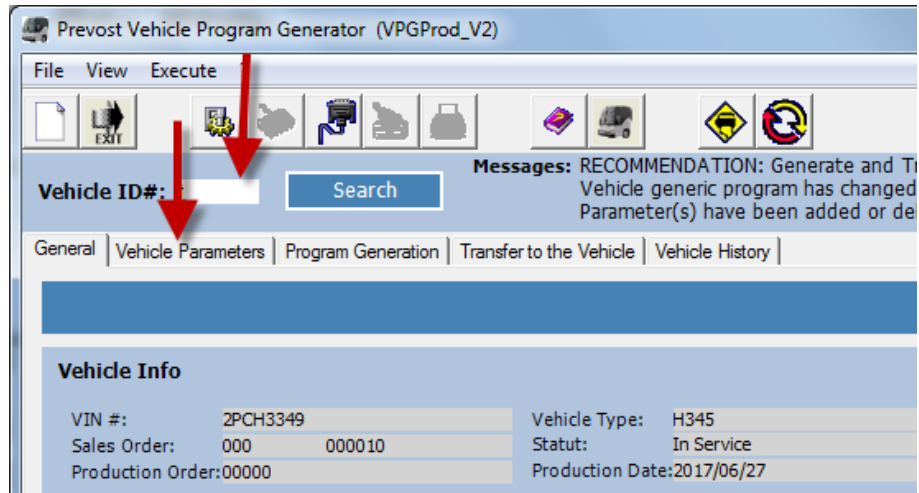

FIGURE 8: VPG

3. On the ISLEEP parameter line, click on the word **No** and Set parameter *ISleep* to **Yes**
4. Generate the program
5. Transfer the program to the vehicle

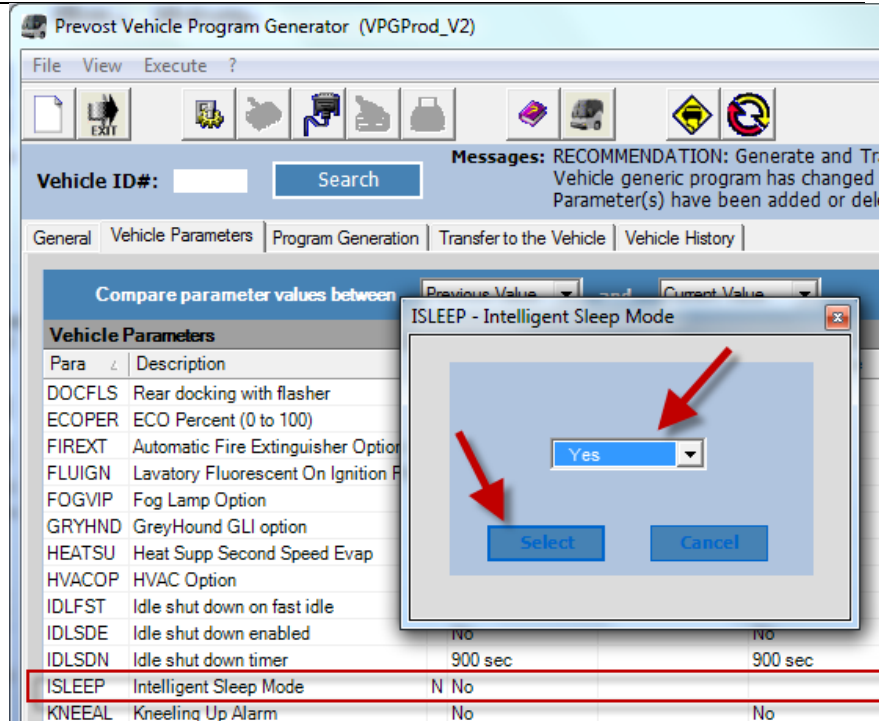

FIGURE 9: ISLEEP PARAMETER

H Series - NEW RELAY ASSEMBLY & INSTALLATION

6. Pre-assemble the relay. Do not tighten the nuts.

560539; M8 Stud

5001787; M8 Nut , SS

5001341; Flat Washer, SS

560529; Relay base

560493; Relay

560538; Cover

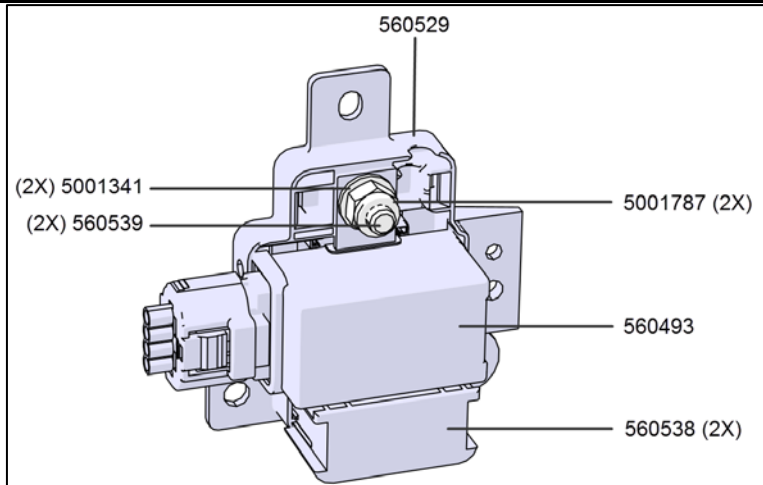

FIGURE 10: RELAY ASSEMBLY

7. Cut and stick two pieces of **506004** foam in the relay base stud cavity.

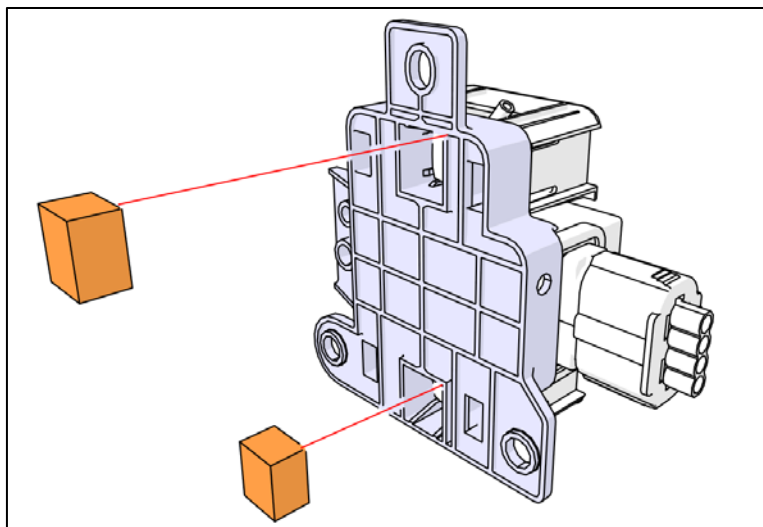

FIGURE 11: ADDING FOAM UNDER RELAY BASE



DANGER

Set the ignition switch to the OFF position and trip the main circuit breakers CB2 & CB6.

8. Create working space in the fore section of the compartment by removing three I/OA modules and the ABS module. (Figure 17)

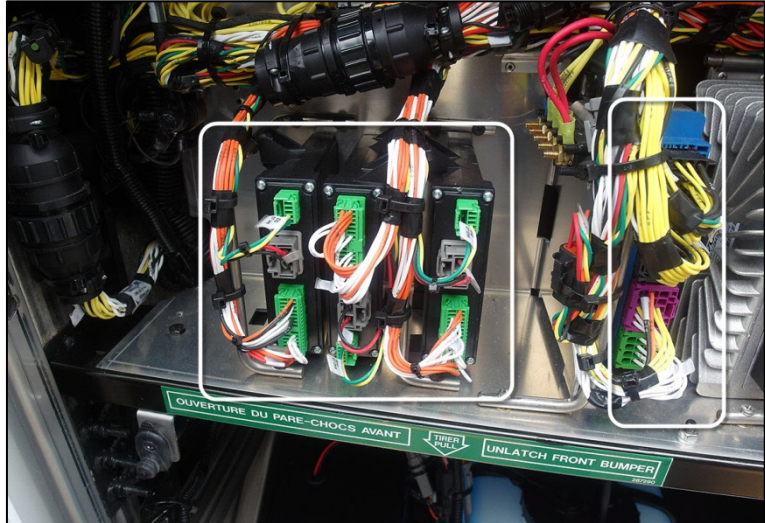

FIGURE 12: I/OA AND ABS MODULES

9. Remove ABS module and customer junction rail mounting bracket.
10. On a working table, mark hole locations as shown on Figure 9. Use relay base as a template.
11. Drill three 3/16" (0.188") holes at marked locations.
12. Use 3 **5001245** self-tapping screws to secure the relay sub-assembly on the plate.

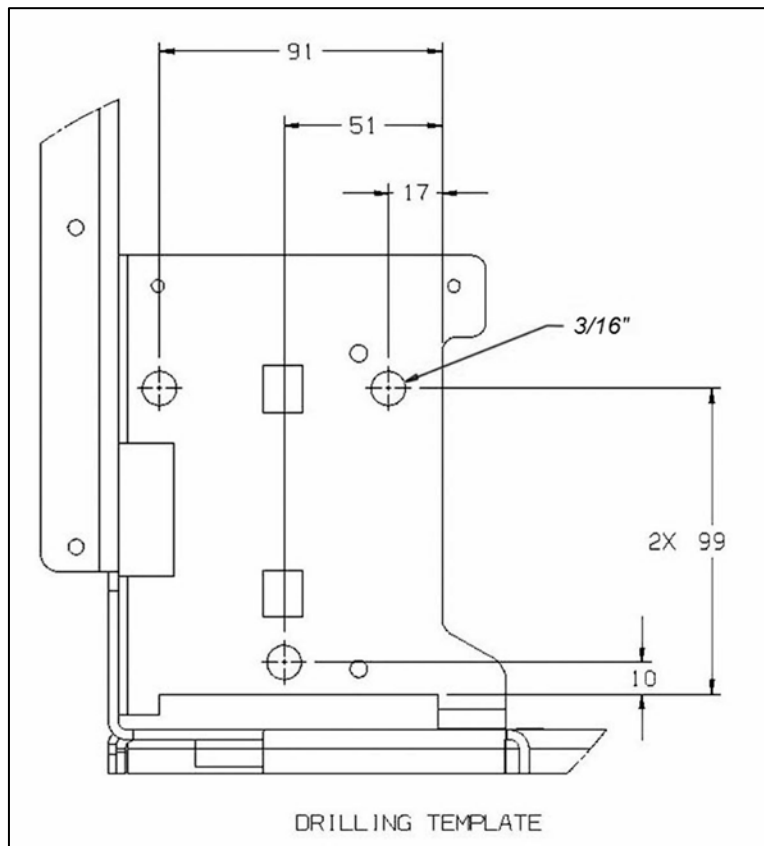

FIGURE 13: DRILLING

FRONT ELECTRICAL COMPARTMENT WIRING

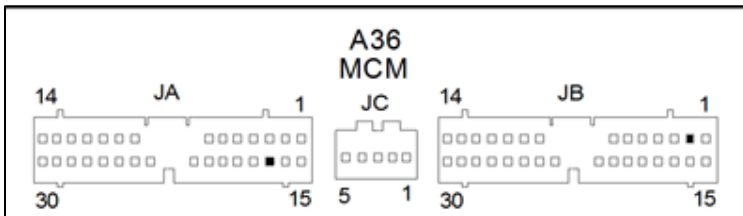

FIGURE 14: A36 PINOUT

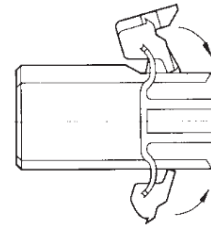

FIGURE 15: A36 CONNECTOR SECONDARY LOCK

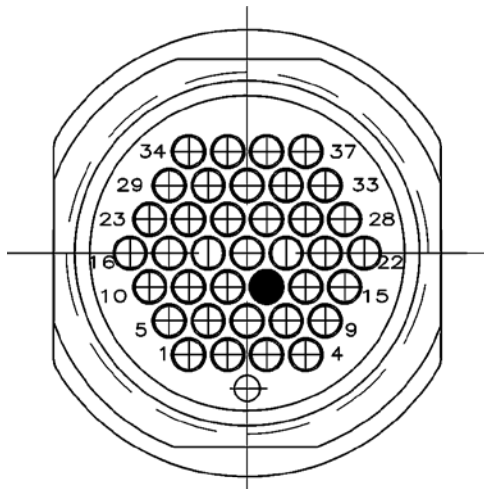

FIGURE 16: C2 PINOUT

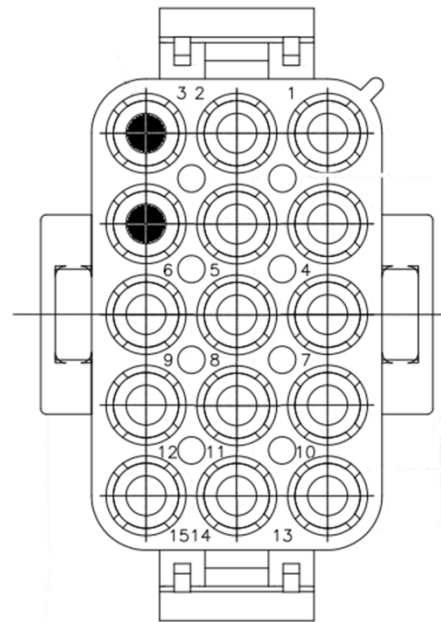

FIGURE 17: C18 PINOUT

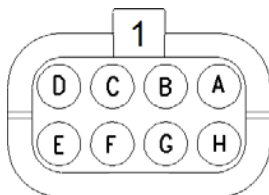

FIGURE 18: VEC TYPICAL CONNECTOR PINOUT

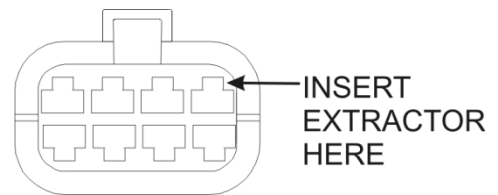

FIGURE 19: VEC TERMINAL EXTRACTION

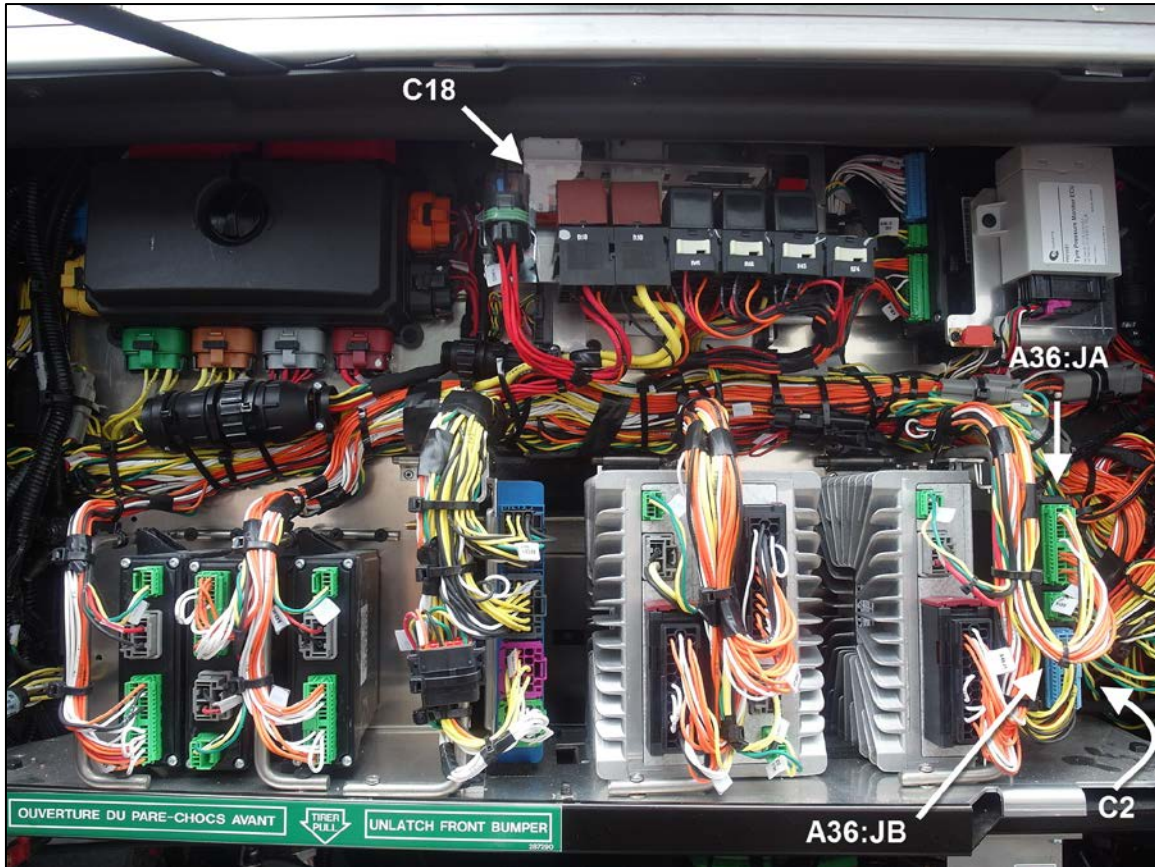

FIGURE 20: CONNECTOR LOCATION OVERVIEW

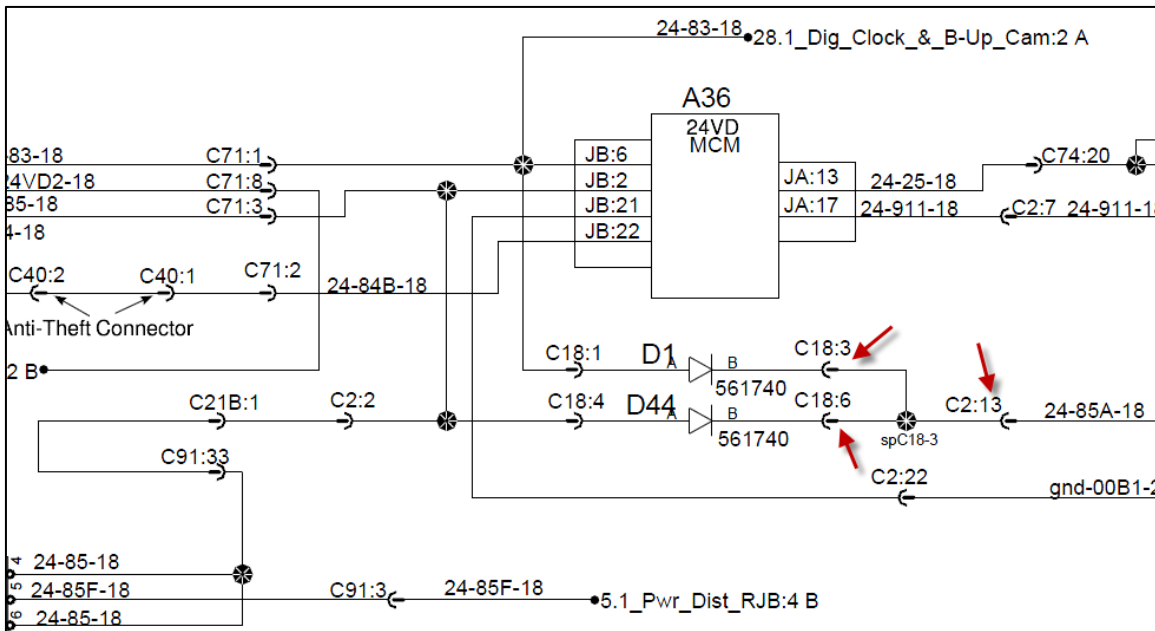

FIGURE 21: C18 & C2 WIRING REMOVAL IN FRONT ELECTRICAL COMPARTMENT

13. Locate A36; C18 and connector C2. (Figure 16) You will find C2 quite deep inside the cavity shown by the arrow, on the ceiling above the pneumatic panel.
14. Disconnect wire 911 JA: 17 of module A36 (Figure 10). Remove terminal using extractor **683766**. Cut terminal and insulate with a heat-shrinkable sleeve. (Figure 18)
15. Disconnect wire 85 from C18:3 pin side using extractor **682257**. Cut terminal and insulate wire with a heat-shrinkable sleeve.
16. Disconnect wire 85 from C18:6 pin side. Cut terminal and insulate wire with a heat-shrinkable sleeve.
17. Disconnect wire 85A from C2:13, socket side. Cut terminal and insulate wire with a heat-shrinkable sleeve.

18. Connect plug R21A from harness 062305 to relay.

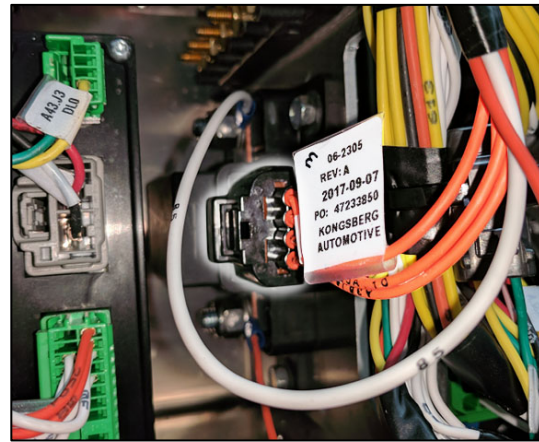

FIGURE 22: CONNECTING TO THE RELAY

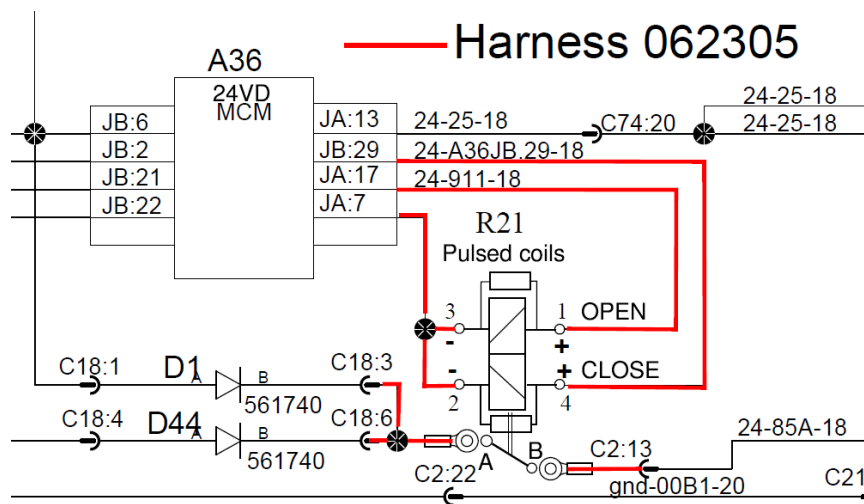

FIGURE 23: 062305 HARNESS INSTALLATION

19. From R21, three (3) wires go directly to the MCM (Figure 20).

Note: If harness 062305 seems tight, remove some of the tape or cable ties used to bundle the harness for shipping.

20. Wire **911** will be connected at pin **17** of the JA connector.

21. The other 2 wires are named:

A36JA:7

A36JB:29

They are connected to **JA:7** and **JB:29**

22. Connect wire **85** with ring terminal to relay at position **A**. Tighten to maximum **13N-m (115 lb-in)**.

23. Connect the two wires **85** labeled C18A to connector **C18**, positions **3** and **6**.

24. Connect wire **85A** with ring terminal at position **B** of the relay, Tighten to maximum **13N-m (115 lb-in)**.

25. Connect wire **85A** labeled C2A to connector C2, position **13**.

26. Re-install removed modules in the front junction box.

CONFIRMING PROPER OPERATION OF ISM

With Battery SOC around 66%, confirm proper operation of sleep mode by leaving internal and external lights on and letting the batteries drain down. Monitor the State of charge in the DID. The system should shut down when either the 24V or 12V SOC falls below 65%.

Secure any harness or connector that was loosened while performing the bulletin.

PARTS / WASTE DISPOSAL

Discard waste according to applicable environmental regulations (Municipal/State[Prov.]/ Federal)
