



# SERVICE BULLETIN

Classification: AT18-011	Reference: NTB19-016	Date: February 19, 2019
-----------------------------	-------------------------	----------------------------

## 2012 – 2019 VERSA SEDAN; ENGINE SUPPORT SPECIAL SERVICE TOOL FOR CVT REMOVAL AND INSTALLATION

**APPLIED VEHICLES:** 2012 – 2019 Versa Sedan (N17)  
**APPLIED TRANSMISSION:** CVT

### SERVICE INFORMATION

A new Engine Support Tool and Engine Support Bracket are now available to allow the CVT to be removed from the Applied Vehicles without having to remove the engine.

The procedure in this bulletin is different than those that are currently in the Electronic Service Manuals (ESMs), which will be updated with this information at a later date.

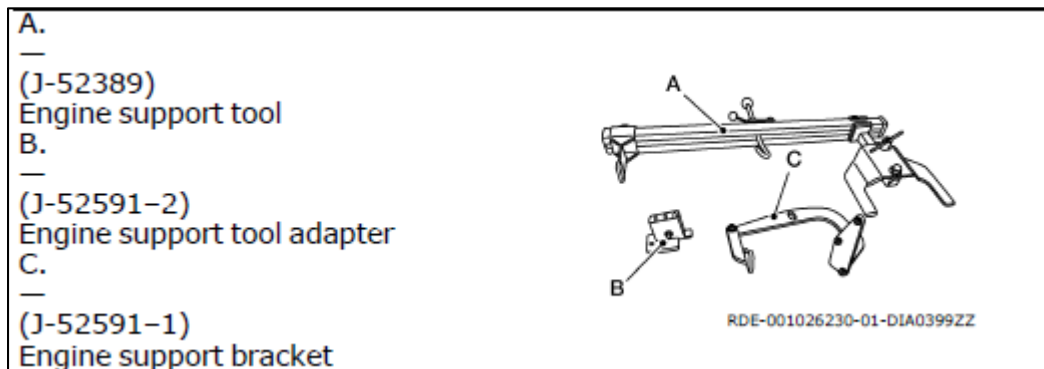

Nissan Bulletins are intended for use by qualified technicians, not 'do-it-yourselfers'. Qualified technicians are properly trained individuals who have the equipment, tools, safety instruction, and know-how to do a job properly and safely. NOTE: If you believe that a described condition may apply to a particular vehicle, DO NOT assume that it does. See your Nissan dealer to determine if this applies to your vehicle.

## Special Service Tool

Tool number (TechMate No.) Tool name	Description
A. — (J-52389) Engine support tool B. — (J-52591-2) Engine support tool adapter C. — (J-52591-1) Engine support bracket	Supporting engine
(J-52473) CVT transmission jack adapter	Removing CVT

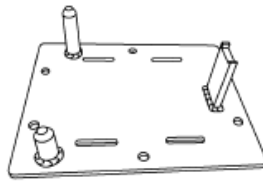
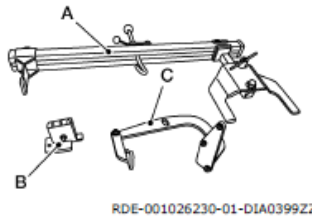

## Commercial Service Tool

Tool number Tool name	Description
Power tool	Loosening nuts, screws and bolts
Hydraulic lift table	Removing front suspension member
Transmission jack	Removing transaxle assembly

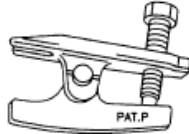
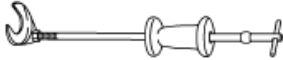

Tool number	Description
<b>Tool name</b> HT72520000 (J-25730-A) Ball joint remover <div style="text-align: center;">  <p>RDE-001026232-04-NT146</p> </div>	Removing outer socket
Drive shaft joint puller <div style="text-align: center;">  <p>RDE-001026232-05-DIA0439ZZ</p> </div>	Removing drive shaft

## Removal & Installation

### REMOVAL

#### **WARNING:**

Do not remove the radiator cap when the engine is hot. Serious burns could occur from high pressure coolant escaping from the radiator. Wrap a thick cloth around the cap. Slowly turn a quarter turn to allow built-up pressure to escape. Carefully remove the cap by turning it all the way.

#### **CAUTION:**

- Perform when the engine is cold.
- When replacing the transaxle assembly, perform "ADDITIONAL SERVICE WHEN REPLACING TRANSAXLE ASSEMBLY". Refer to "Description" in the Transaxle and Transmission section of the ESM.
- When replacing TCM and transaxle assembly simultaneously, perform "ADDITIONAL SERVICE WHEN REPLACING TCM AND TRANSAXLE ASSEMBLY". Refer to "Description" in the Transaxle and Transmission section of the ESM.

#### **NOTE:**

When removing components such as hoses, tubes/lines, etc., cap or plug openings to prevent fluid from spilling.

1. Loosen upper pinch bolt of lower joint. Refer to Steering Shaft "Exploded View" in the Steering System section of the ESM.
2. Remove lower pinch bolt from lower joint and separate lower joint from steering gear. Refer to Steering Shaft "Exploded View" in the Steering System section of the ESM.
3. Remove air cleaner assembly. Refer to "Removal and Installation" in the Engine Mechanical section of the ESM.
4. Remove battery. Refer to "Removal and Installation" in the Power Supply, Ground Circuit Elements section of the ESM.

5. Remove bolt (A) and ground (B) from TCM bracket.

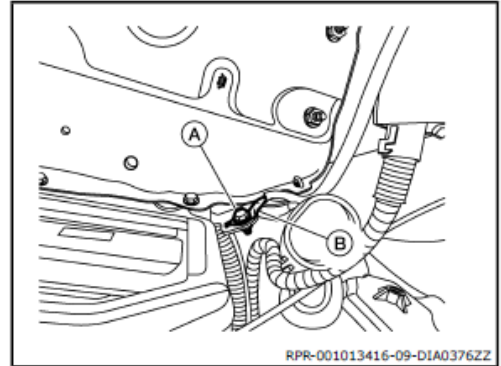

6. Remove TCM bolts and set TCM aside. Refer to "Exploded View" in the Transaxle and Transmission section of the ESM.

7. Remove bolts (A) and cover (1).

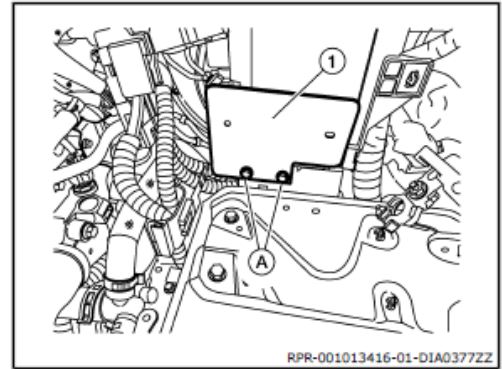

8. Remove bolts (A).

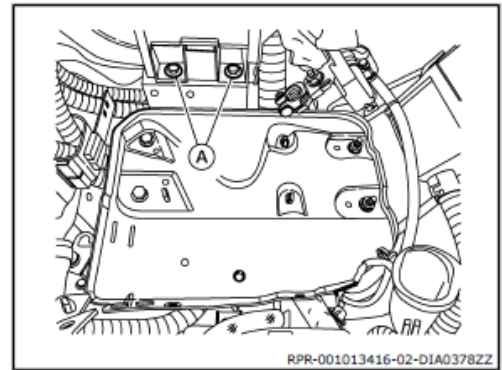

9. Remove nuts (A) and remove harness bracket (B) from battery tray (1).

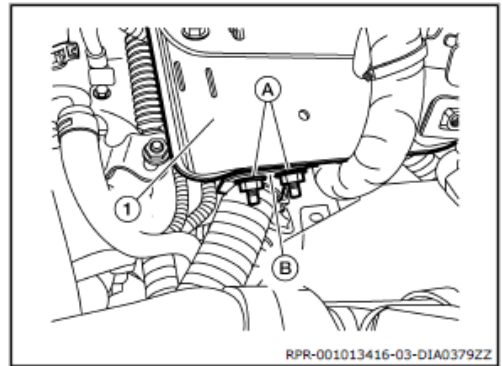

10. Remove bolts (A) and nuts (C).

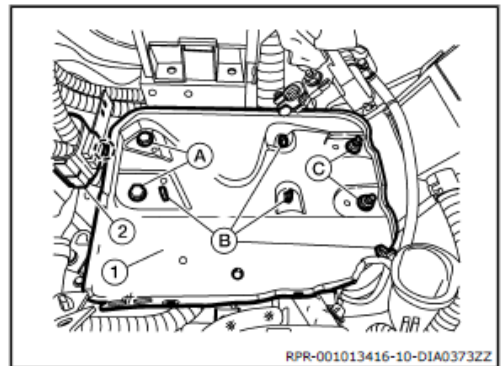

11. Release pawl and separate battery positive cable (2) from battery tray (1).

 : Pawl

12. Using suitable tool release harness retainers (B) and lift battery tray.

13. Using suitable tool, release harness retainer (A) and remove battery tray (1).

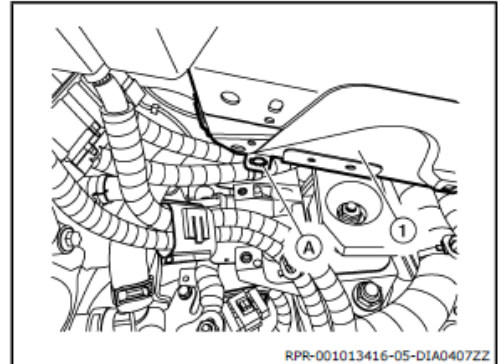

14. Disconnect the harness connector (A) from EVAP canister purge volume control solenoid valve.

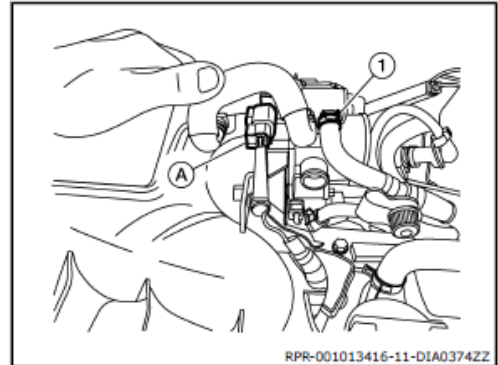

15. Disconnect EVAP hose (1) from EVAP canister purge volume control solenoid valve.  
16. Disconnect vacuum hoses (1) and (2) from intake manifold (3).

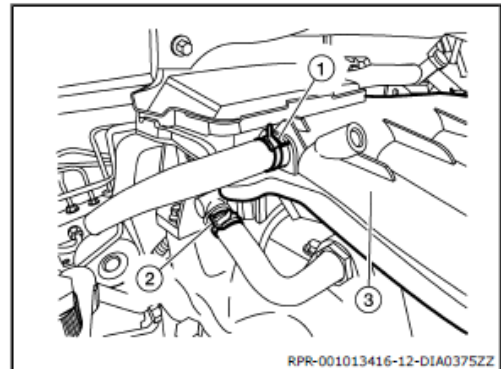

17. Drain the coolant. Refer to "Draining Engine Coolant" in the Engine Cooling System section of the ESM.  
18. Remove water hoses from electric throttle control actuator. Refer to Intake Manifold "Exploded View" in the Engine Mechanical section of the ESM.  
19. Disconnect the harness connector from the electric throttle control actuator. Refer to "Exploded View" in the Engine Mechanical section of the ESM.  
20. Remove bolts and remove intake manifold. Refer to "Exploded View" in the Engine Mechanical section of the ESM.

21. Remove bolt (A) and position bracket (1) and harness (2) aside.

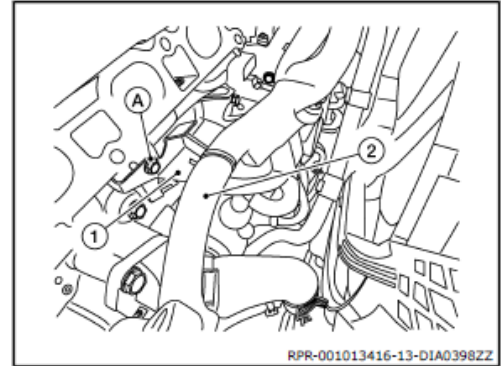

22. Disconnect the harness connector from the knock sensor. Refer to "Component Parts Location" in the Engine Control System section of the ESM.
23. Remove nuts and remove "S" terminal and "B" terminal harnesses from starter motor. Refer to Starter Motor "Exploded View" in the Starting System section of the ESM.
24. Remove starter motor bolts and remove starter motor. Refer to Starter Motor "Exploded View" in the Starting System section of the ESM.
25. Remove lock plate (1).

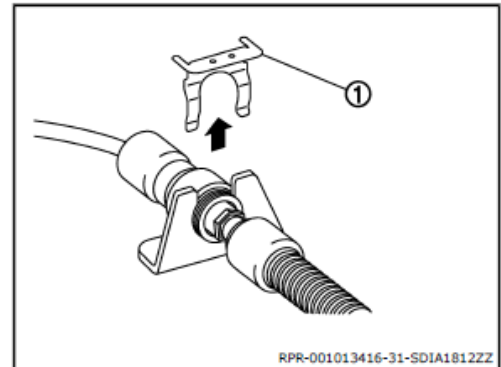

26. Remove nut (A) and remove the control cable (1) from the manual lever bracket (2). Position control cable aside.

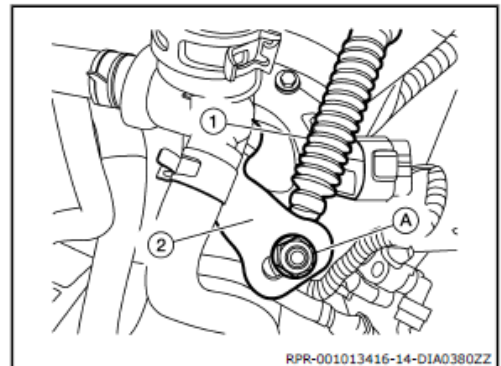

27. Disconnect the harness connector from the transmission range switch.
28. Using a suitable tool, release clip.



: Clip  
: Pawl

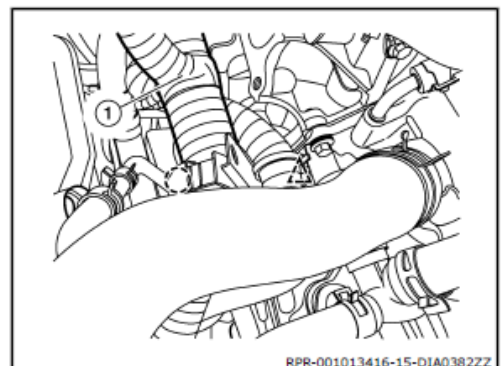

29. Using a suitable tool, release pawl and set harness (1) aside.

30. Remove bolt from bracket and set water hose A aside. Refer to Water Hose "Exploded View" in the Transaxle and Transmission section of the ESM.
31. Remove the front wheel and tire assemblies (LH/RH) using power tool.
32. Remove both front fender protectors (LH/RH). Refer to Fender Protector "Removal and Installation" in the Exterior section of the ESM.
33. Remove the brake caliper torque member bolts, leaving the brake hose attached. Position the brake caliper aside and support with wire. Refer to Brake Caliper Assembly "Exploded View" in the Brake System section of the ESM.

**CAUTION:**

- Do not depress the brake pedal while the brake caliper is removed.
- Do not allow the brake caliper to hang by the brake hose or damage could result.

34. Put alignment marks on the disc brake rotor and on the wheel hub and bearing. Remove the disc brake rotor (LH/RH).

**CAUTION:**

**Do not drop disc brake rotor.**

35. Remove the cotter pin from the front drive shaft (LH/RH). Refer to "Exploded View" in the Front Axle section of the ESM.

**CAUTION:**

**Do not reuse cotter pin.**

36. Loosen the wheel hub lock nut (LH/RH).

37. Remove the front wheel sensor bolt (LH/RH). Position the front wheel sensor and the wheel sensor harness aside. Refer to Front Wheel Sensor "Exploded View" in the Brake Control System section of the ESM.

**CAUTION:**

- Do not damage front wheel sensor or sensor rotor.
- Pull out front wheel sensor being careful to turn it as little as possible. Do not pull on front wheel sensor harness.

38. Using a piece of wood and suitable tool, tap on the wheel hub lock nut to disengage the drive shaft from the wheel hub and bearing (LH/RH).

**CAUTION:**

- Do not place the drive shaft joint at an extreme angle. Also be careful not to overextend slide joint.
- Do not allow the drive shaft to hang down without support.

**NOTE:**

Use a suitable puller if the drive shaft cannot be separated from the wheel hub and bearing even after performing the above procedure.

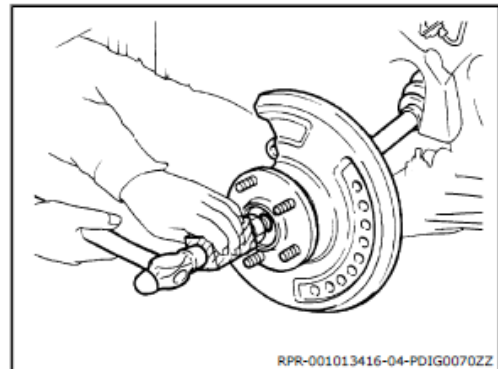

39. Completely remove the wheel hub lock nut (LH/RH).

**CAUTION:**

**Do not reuse wheel hub lock nuts.**

40. Remove the nut and lower pinch bolt from the steering knuckle (LH/RH). Refer to Front Wheel Hub and Knuckle "Exploded View" in the Front Axle section of the ESM.

**CAUTION:**

**Do not reuse lower pinch bolt nuts.**

41. Remove nut and separate stabilizer connecting rod from strut (LH/RH). Refer to Front Stabilizer "Exploded View" in the Front Suspension section of the ESM.

**CAUTION:**

**Do not reuse stabilizer connecting rod nuts.**



42. Loosen the outer socket nut and separate outer socket from the steering knuckle using Tool (LH/RH). Refer to Steering Gear and Linkage "Exploded View" in the Front Suspension section of the ESM.

Tool number : HT72520000 (J-25730-A)

**CAUTION:**

Leave the outer socket nut half threaded on the outer socket to prevent damage to the threads and to prevent the Tool from coming off suddenly.

43. Completely remove outer socket nuts (LH/RH).

**CAUTION:**

Do not reuse nuts.

44. Remove nuts (A) and separate exhaust mount (1) from front suspension member (2).

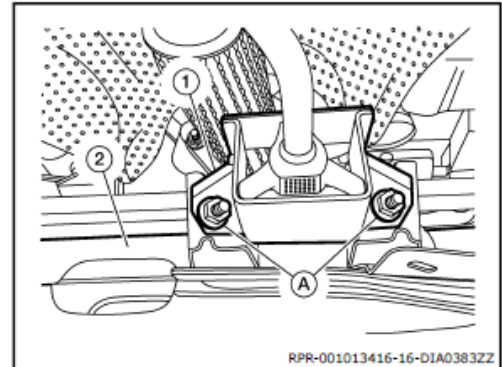

45. Remove bolts securing rear engine mounting bracket to Transaxle. Refer to Engine Assembly "Exploded View" in the Engine Mechanical section of the ESM.

46. Set hydraulic lift table (A) or equivalent tool under front suspension member.

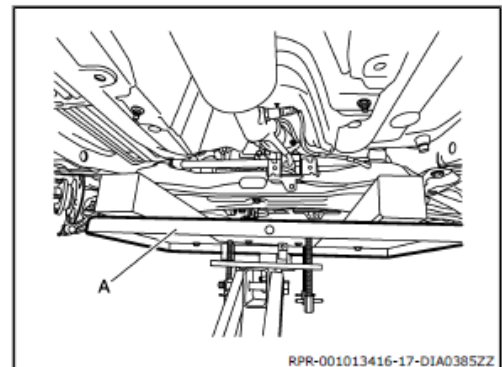

47. Remove front suspension member bolts. Refer to Front Suspension Member "Exploded View" in the Front Suspension section of the ESM.
48. Slowly lower hydraulic lift table (or equivalent tool) to remove the front suspension member from the vehicle.

**CAUTION:**

Secure front suspension member the hydraulic lift table (or equivalent tool) while removing it.

49. Remove drive shaft from wheel hub and bearing (LH/RH).

50. Insert suitable tool (A) between the drive shaft and transaxle. Remove the drive shaft from the transaxle (LH/RH).

**CAUTION:**

- Confirm that the circular clip is attached to the drive shaft.
- Do not place drive shaft joint at an extreme angle when removing drive shaft. Also be careful not to overextend slide joint.

Tool (A)

: Drive shaft joint puller  
(Commercially available)

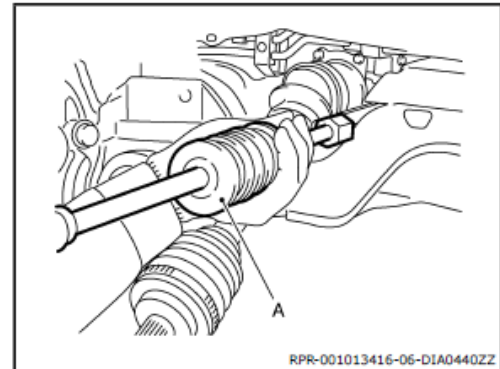

51. Remove the nut (A) and bolts (B) and remove shield (1).

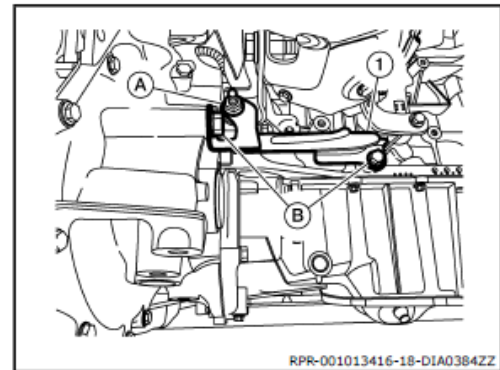

52. Disconnect the harness connector from the primary speed sensor. Refer to Primary Speed Sensor "Exploded View" in the Transaxle and Transmission section of the ESM.
53. Disconnect the harness connector from the secondary speed sensor. Refer to Secondary Speed Sensor "Exploded View" in the Transaxle and Transmission section of the ESM.
54. Disconnect the harness connector from the output speed sensor. Refer to Output Speed Sensor "Exploded View" in the Transaxle and Transmission section of the ESM.
55. Remove bolt (A) and position ground (1) aside.

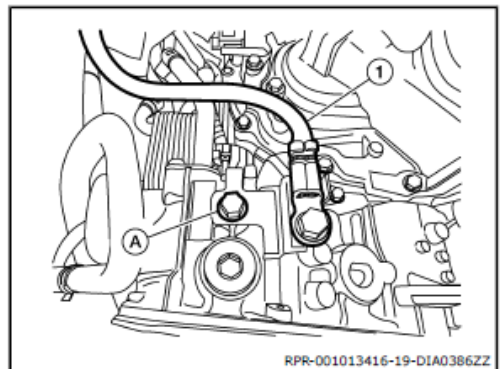

56. Disconnect the harness connector (A) from the transaxle assembly.

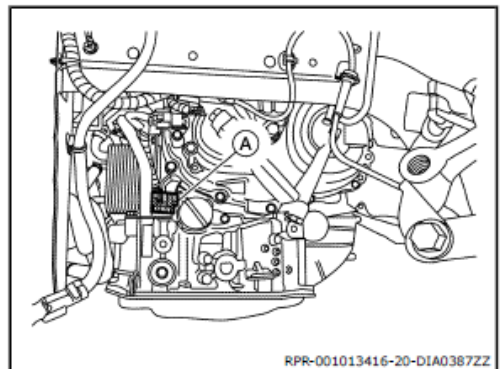

57. Remove torque converter nuts.
58. Remove CVT oil cooler hose A and CVT cooler hose B from CVT oil warmer. Refer to Fluid Cooler Hose "Exploded View" in the Transaxle and Transmission section of the ESM.

59. Remove water hose A and water hose C from CVT oil warmer. Refer to Water Hose "Exploded View" in the Transaxle and Transmission section of the ESM.
60. Remove bolt and set heater thermostat aside. Refer to Water Hose "Exploded View" in the Transaxle and Transmission section of the ESM.

61. Install Tool (C) to the front of engine using bolts (B) supplied with Tool. Tighten bolts to specification. Refer to Engine Support Tool Operating Instructions.

Tool (C) : (J-52591-1)  
Bolts (B) : 21 Nm (15 ft-lb, 2.1 kg-m)

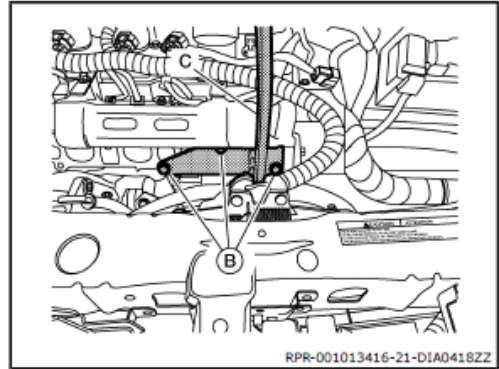

62. Install Tool (C) to rear of the engine using bolts (B) supplied with Tool. Refer to Engine Support Tool Operating Instructions.

Tool (C) : (J-52591-1)  
Bolts (B) : 21 Nm (15 ft-lb, 2.1 kg-m)

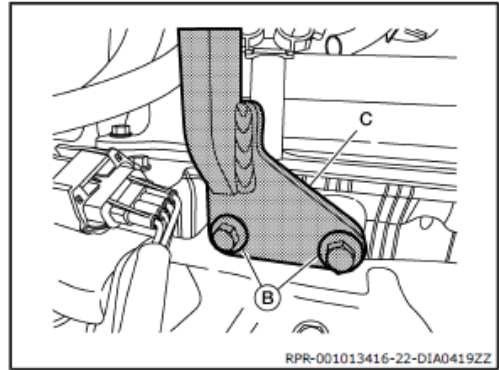

63. Remove bolts (A) and (B) and remove bracket (1).

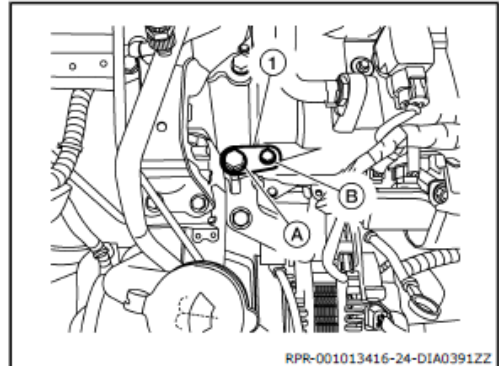

64. Install Tool (B) as shown with supplied bolt (C). Refer to Engine Support Tool Operating Instructions.

Tool (B) : (J-52591-2)  
Bolt (C) : 21 Nm (15 ft-lb, 2.1 kg-m)

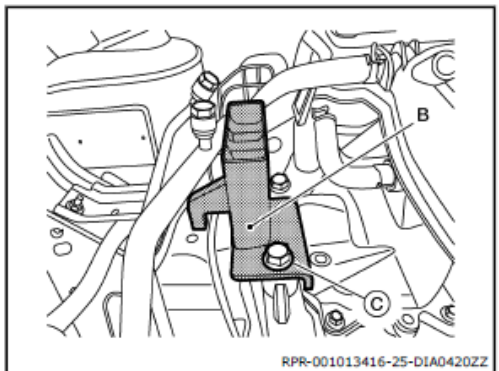

65. Disconnect the harness connectors (A) from the ECM (1).



: Front

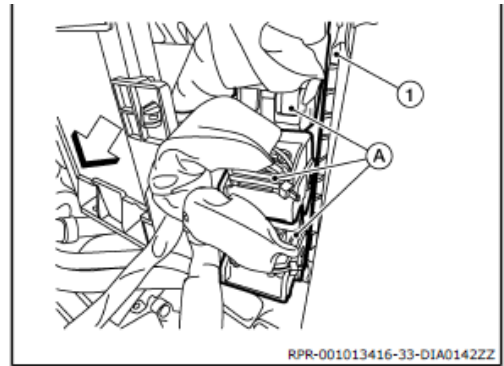

66. Using a suitable tool, release harness retainer (A) and position harness (1) aside.

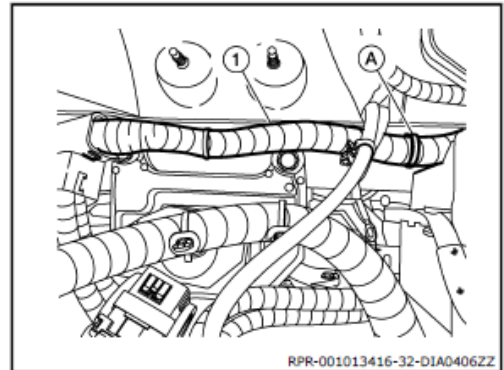

67. Install Tool on the driver's side frame rail using the following steps. Refer to Engine Support Tool Operating Instructions.

Tool number : (J-52389)

1. Install rear portion of Tool (A) on driver's side frame rail (1) as shown. Refer to Engine Support Tool Operating Instructions.

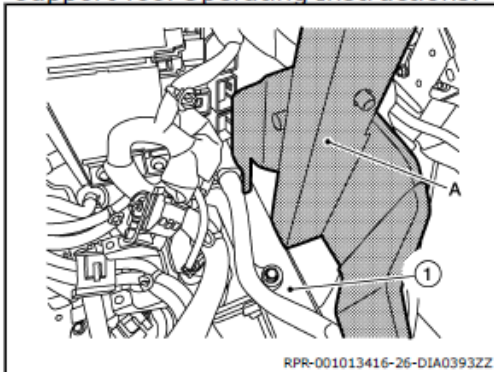

Tool (A) : (J-52389)

2. Install front portion of Tool (A) on driver's side frame rail (1) as shown. Refer to Engine Support Tool Operating Instructions.

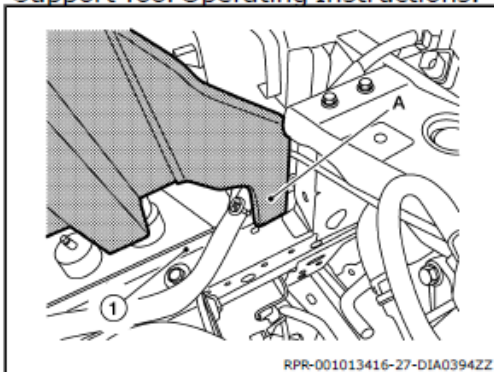

Tool (A) : (J-52389)

68. Install Tool (A) to Tool (B) as shown. Refer to Engine Support Tool Operating Instructions.

Tool (A) : (J-52389)  
Tool (B) : (J-52591-2)

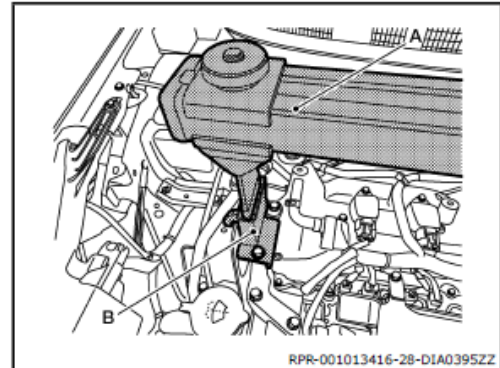

69. Install Tool (A) to Tool (C) as shown. Refer to Engine Support Tool Operating Instructions.

Tool (A) : (J-52389)  
Tool (C) : (J-52591-1)

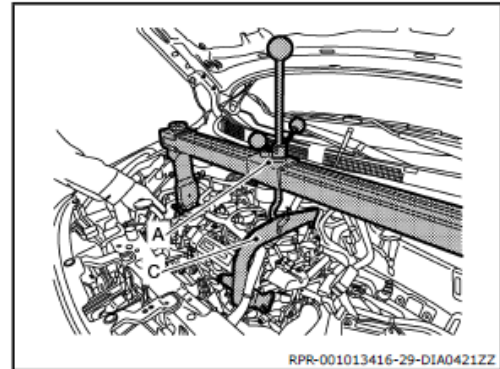

70. Using bubble level (B) on Tool (A) level Tool as shown. Refer to Engine Support Tool Operating Instructions.

Tool (A) : (J-52389)

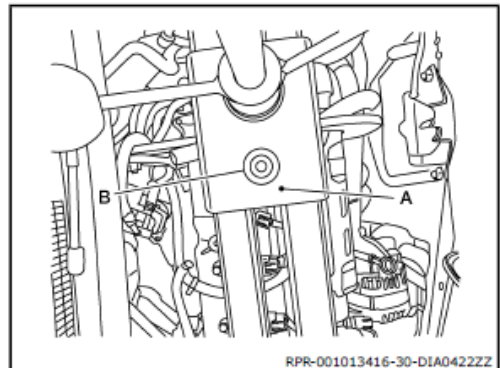

71. Tighten handle of Tool (A) to support the weight of the engine and transaxle assembly. Refer to Engine Support Tool Operating Instructions.

**CAUTION:**

**Before removing engine or transmission mount bolts, ensure that the engine support tool is properly installed and supporting the weight of the engine and transaxle assembly, otherwise damage could result.**

Tool (A) : (J-52389)

72. Separate harness retainers from transaxle assembly.

73. Loosen engine mounting bracket (LH) nut. Refer to Engine Assembly "Exploded View" in the Engine Mechanical section of the ESM.

74. Using a suitable tool release engine mounting bracket (LH) from engine mounting insulator (LH).

75. Remove nut from engine mounting bracket (LH).

76. Remove upper bolts (A), (B), (C) from the transaxle assembly.

**NOTE:**

**It will be necessary to manually rotate manual lever for better access to transaxle bolts.**

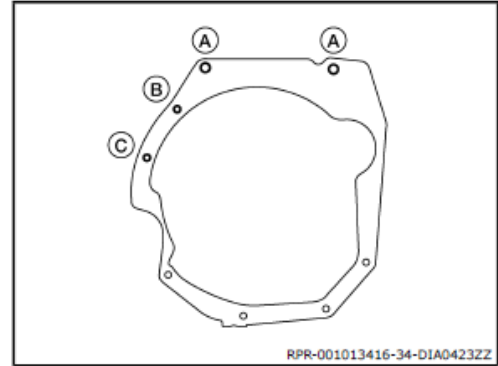

77. Using Tools lower engine and transaxle assembly until the transaxle assembly is low enough to clear the driver's side frame rail.

Tool number : (J-52591-1, J-52389)

78. Raise vehicle on hoist.

79. Support transaxle assembly using a suitable transmission jack and Tool.

Tool number : (J-52473)

**CAUTION:**

- Always secure transaxle assembly to transmission jack.
- Do not lift or support transaxle assembly using the bottom of oil pan or damage can occur.

80. Remove bolts and remove engine mounting bracket (LH). Refer to Engine Assembly "Exploded View" in the Engine Mechanical section of the ESM.

81. Remove remaining bolts (A) and (B) from the transaxle to engine assembly.

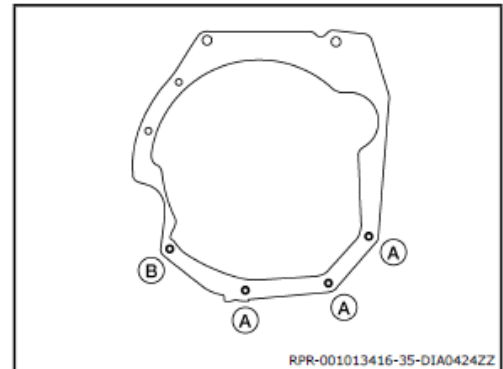

82. Separate the transaxle assembly from the engine assembly and lower the transaxle assembly.

**CAUTION:**

**Secure the torque converter to the transaxle while removing the transaxle to prevent the torque converter from falling.**

## INSTALLATION

Installation is in the reverse order of removal.

Perform inspection before installation. Refer to "Inspection Before Installation" below.

**NOTE:**

- If the same transaxle assembly will be reinstalled, replace differential side oil seals (LH/RH). Refer to Differential Side Oil Seal "Exploded View" in the Transaxle and Transmission section of the ESM.
- If a new transaxle assembly is being installed, write down the serial number of the new transaxle assembly.

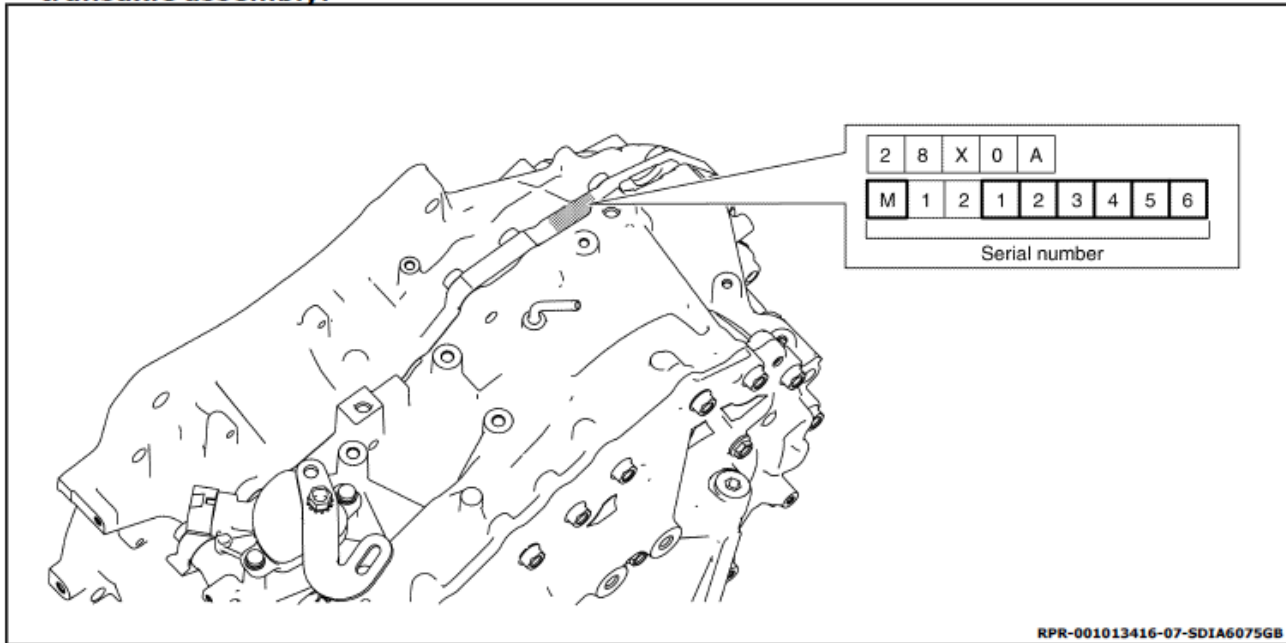

**CAUTION:**

- When replacing an engine or transaxle you must make sure any dowels are installed correctly during re-assembly.
- Improper alignment caused by missing dowels may cause vibration, oil leaks or breakage of drive train components.
- Do not reuse O-rings or copper sealing washers.
- When turning crankshaft, turn it clockwise as viewed from the front of the engine.
- When tightening the nuts for the torque converter while securing the crankshaft pulley bolt, be sure to confirm the tightening torque of the crankshaft pulley bolt. Refer to "Removal and Installation" in the Engine Mechanical section of the ESM.
- After converter is installed to drive plate, rotate crankshaft several turns to check that CVT rotates freely without binding.
- Do not reuse differential side oil seals.
- When installing the CVT to the engine, align the matching mark on the drive plate with the matching mark on the torque converter.



**NOTE:**

- When installing the torque converter nuts, temporarily tighten the nuts. Then, after installing the engine and transaxle assembly bolts tighten the nuts to the specified torque.

**Tightening torque : 51 Nm (5.2 kg-m, 38 ft-lb)**

- Install the transaxle assembly and engine assembly mounting bolts according to the following standards.

Bolt position	A	B	C	D
Direction of insertion	Transaxle assembly = Engine assembly	Engine assembly = Transaxle assembly		
Quantity	2	2	1	3
Nominal length [mm (in)]	40 (1.57)	44 (1.73)	69 (2.72)	49 (1.93)
Tightening torque N·m (kg-m, ft-lb)	48.0 (4.9, 35)			

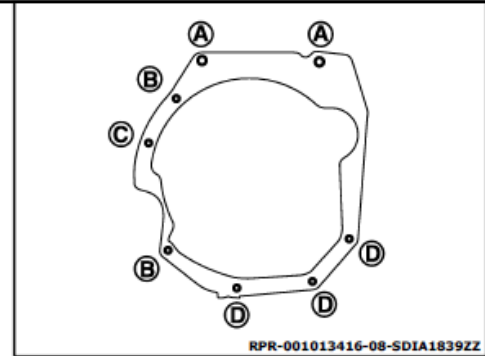

**INSPECTION BEFORE INSTALLATION**

Check the dimension (A) between the converter housing and torque converter.

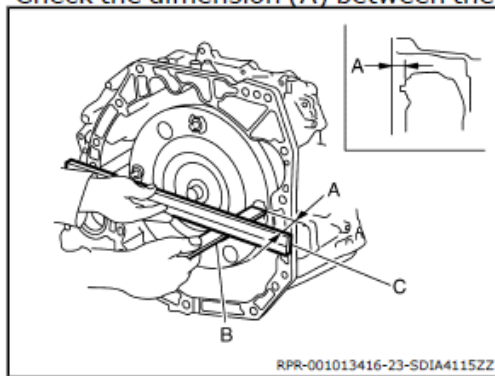

- B : Scale
- C : Straightedge

Dimension (A) : Refer to "Torque Converter" in the Transaxle and Transmission section of the ESM.

**ADJUSTMENT AFTER INSTALLATION**

- Adjust CVT position. Refer to "Adjustment" in the Transaxle and Transmission section of the ESM.
- Check and adjust the engine coolant level. Refer to "Engine Coolant" in the Engine Cooling System section of the ESM.
- Adjust the CVT fluid level. Refer to "Adjustment" in the Transaxle and Transmission section of the ESM.
- Perform "ADDITIONAL SERVICE WHEN REPLACE CONTROL VALVE OR TRANSAXLE ASSEMBLY". Refer to "Description" in the Transaxle and Transmission section of the ESM.
- Perform front wheel alignment. Refer to "Wheel Alignment" in the Front Suspension section of the ESM.

- Perform adjustment of steering angle sensor neutral position. Refer to "Description" in the Brake Control System section of the ESM.
- Perform accelerator pedal released position learning. Refer to "Description" in the Engine Control System section of the ESM.
- Perform throttle valve closed position learning. Refer to "Description" in the Engine Control System section of the ESM.

### INSPECTION AFTER INSTALLATION

Check the following items:

- CVT fluid leakage, refer to "Inspection" in the Transaxle and Transmission section of the ESM.
- For CVT shifter position, refer to "Inspection" in the Transaxle and Transmission section of the ESM.
- Start the engine and check for coolant leaks.

### CLAIMS INFORMATION

MODEL	DESCRIPTION	OP CODE	FRT
Versa Sedan	CVT R&I	JD01AA	(1)

(1) The new procedure in this bulletin will alter the Flat Rate Time (FRT) for operations involving removal of the CVT from the vehicle. Refer to the current Nissan Warranty Flat Rate Manual for current FRTs.

### AMENDMENT HISTORY

PUBLISHED DATE	REFERENCE	DESCRIPTION
February 19, 2019	NTB19-016	Original bulletin published