



Technical Service Bulletin

SUBJECT:		No:	TSB-19-54-005
ADDITION OF MAIN DRIVE LITHIUM-ION BATTERY DISASSEMBLY & MAINTENANCE PROCEDURE - SERVICE MANUAL REVISION		DATE:	March 2019
		MODEL:	2016 i-MiEV
CIRCULATE TO:	<input type="checkbox"/> GENERAL MANAGER	<input checked="" type="checkbox"/> PARTS MANAGER	<input checked="" type="checkbox"/> TECHNICIAN
<input checked="" type="checkbox"/> SERVICE ADVISOR	<input checked="" type="checkbox"/> SERVICE MANAGER	<input type="checkbox"/> WARRANTY PROCESSOR	<input type="checkbox"/> SALES MANAGER

PURPOSE

This TSB updates the Chassis Electrical section of the affected Service Manual to add the **Main Drive Lithium-ion Battery Disassembly & Maintenance** procedure to 54D-Electric Motor Unit and Main Drive Lithium-ion Battery.

The information in this bulletin should be added after "**Main Drive Lithium-ion Battery Removal and Installation.**"

AFFECTED VEHICLES

- 2016 i-MiEV

AFFECTED SERVICE MANUALS

- 2016 i-MiEV Service Manual, Group 54-Chassis Electrical



GROUP 54D

ELECTRIC MOTOR UNIT AND MAIN DRIVE LITHIUM-ION BATTERY

CONTENTS

GENERAL INFORMATION	54D-4	DTC P1AFB QUICK CHARGING TIME OVER	54D-57
PRECAUTIONS BEFORE SERVICE.	54D-4	DTC P1AFC QUICK CHARGING CURRENT	54D-60
PRECAUTIONS	54D-4	DTC P1AFD QUICK CHARGING VOLTAGE	54D-62
EV-ECU	54D-5	DTC P1B01 QUICK CHARGER VEHICLE ERROR	54D-66
DIAGNOSTIC TROUBLE CODE CHART ..	54D-5	DTC P1B04 CHARGING CELL MAX VOLTAGE HIGH, P1B05 CHARGING CELL MIN VOLTAGE LOW, P1B07 CHARGING TOTAL BATTERY VOLTAGE	54D-71
DIAGNOSTIC TROUBLE CODE PROCEDURES	54D-6	DTC P1B06 CHARGING CELL MAX TEMPERATURE HIGH	54D-73
DTC P0A0A INTER LOCK SW	54D-6	DTC P1B0C ON BOARD CHARGING OVER CURRENT, P1B21 OBC OUTPUT CURRENT	54D-74
DTC P0AA1 MAIN CONTACTOR P WELD	54D-9	DTC P1B0D QUICK CHARGING OVER CURRENT	54D-76
DTC P0AA4 MAIN CONTACTOR N WELD	54D-14	DTC P1B72 QUICK CHARGER CHARGING CURRENT 1	54D-78
DTC P0ADB MAIN CONTACTOR P CIRCUIT LOW, P0ADF MAIN CONTACTOR N CIRCUIT LOW	54D-18	DTC P1B73 QUICK CHARGER CHARGING CURRENT 2	54D-81
DTC P0AE2 PRE-CHARGE CONTACTOR WELD	54D-21	DTC P1B74 QUICK CHARGER DIS-CHARGING CURRENT 1	54D-83
DTC P0AE6 PRE-CHARGE CONTACTOR CIRCUIT LOW, P0AE7 PRE-CHARGE CONTACTOR CIRCUIT HIGH	54D-26	DTC P1B75 QUICK CHARGER DIS-CHARGING CURRENT 2	54D-86
DTC P101B Quick CHG.contactor P weld ..	54D-29	DTC P1B76 QUICK CHARGER DIS-CHARGING CURRENT 3	54D-89
DTC P101C Quick CHG.contactor N weld ..	54D-32	DTC P1B77 QUICK CHARGER DIS-CHARGING CURRENT 4	54D-91
DTC P1A15 HIGH VOLTAGE CIRCUIT (1)	54D-36		
DTC P1A17 HIGH VOLTAGE CIRCUIT (3)	54D-47		
DTC P1AFA QUICK CHARGER READY TIMEOUT, P1AFE QUICK CHARGER MALFUNCTION, P1AFF QUICK CHARGER CONNECTOR LOCK, P1B00 QUICK CHARGER BATTERY ERROR ...	54D-52		

DTC P1B78 QUICK CHARGER RECEIVED CURRENT.....	54D-94	CODE NO. P1AXX: CMU01 MODULE TEMPERATURE ABNORMAL (LOW INPUT)	54D-147
DTC U111C BMU CAN TIMEOUT	54D-97	CODE NO. P1AC1: TRACTION BATTERY FAN FAILED (DRIVING ABNORMAL)	54D-148
ELECTRIC MOTOR CONTROL UNIT (EMCU) AND MOTOR (ELECTRIC MOTOR UNIT)	54D-98	CODE NO. P1AC2: TRACTION BATTERY FAN FAILED (SHORT CIRCUITS TO POWER SUPPLY SYSTEM).....	54D-152
DIAGNOSTIC TROUBLE CODE CHART ..	54D-98	CODE NO. P1AC3: TRACTION BATTERY FAN FAILED (STOP ABNORMAL)	54D-156
DIAGNOSTIC TROUBLE CODE PROCEDURES	54D-99	CODE NO. P1AC6: VOLTAGE OF EACH BATTERY CELL ABNORMAL (HI SIDE)	54D-159
DTC P0A0D MOTOR DRIVE VOLTAGE HIGH (HW DETECT).....	54D-99	CODE NO. P1ADF: +B LINE VOLTAGE... ..	54D-161
BATTERY MANAGEMENT UNIT (BMU) AND MAIN DRIVE LITHIUM-ION BATTERY	54D-101	CODE NO. P1AE0: CLOCK IC TIME COUNTER	54D-163
SPECIAL TOOLS	54D-101	CODE NO. P1AE1: CLOCK IC ALARM ...	54D-164
RECOMMENDED TOOLS	54D-103	CODE NO. P1AE3: BMU TEMP. SENSOR (OPEN/SHORT).....	54D-165
INSPECTION CHART FOR DIAGNOSIS CODE	54D-105	CODE NO. P1AE4: BMU TEMP. SENSOR (RATIONALITY).....	54D-165
DIAGNOSTIC CODE PROCEDURES	54D-108	CODE NO. U1082: LOCAL CAN (FOR TRACTION BATTERY) BUS OFF	54D-166
CODE NO. P1A40: TRACTION BATTERY CURRENT SENSOR (HIGH) ABNORMAL	54D-108	CODE NO. U11A0: CMU01 TIME-OUT ...	54D-169
CODE NO. P1A41: TRACTION BATTERY CURRENT SENSOR (LOW) ABNORMAL	54D-110	CODE NO. U1925: CMU ID NUMBERING RECEPTION ERROR	54D-175
CODE NO. P1A42: POWER SUPPLY CIRCUIT OF TRACTION BATTERY CURRENT SENSOR ABNORMAL	54D-112	CODE NO. U1926: EV-ECU CAN ABNORMAL	54D-179
CODE NO. P1A43: DETECTION CIRCUIT OF TRACTION BATTERY CURRENT SENSOR ABNORMAL	54D-113	ON-VEHICLE SERVICE	54D-181
CODE NO. P1A44: DETECTING GROUND FAULT	54D-115	CHECK ON COIL RESISTANCE OF CONTACTOR	54D-181
CODE NO. P1A46: DETECTION CIRCUIT OF TRACTION BATTERY GROUND FAULT DETECTOR ABNORMAL	54D-130	CHECK ON SERVICE PLUG SWITCH....	54D-184
CODE NO. P1A48: OUTPUT CIRCUIT OF TRACTION BATTERY FAN ABNORMAL	54D-132	LOCAL CAN (FOR TRACTION BATTERY) TERMINATING RESISTANCE CHECK ...	54D-185
CODE NO. P1AXX: CMU01 MODULE TEMPERATURE ABNORMAL (HIGH INPUT)	54D-134	CHECK AND REPLACEMENT OF THE HIGH-VOLTAGE FUSE INSIDE THE MAIN DRIVE LITHIUM-ION BATTERY.....	54D-186
CODE NO. P1AXX: CMU01 BATTERY CELL VOLTAGE SENSOR ABNORMAL	54D-136	BATTERY MANAGEMENT UNIT (BMU)... ..	54D-188
CODE NO. P1AXX: CMU01 MODULE TEMPERATURE SENSOR ABNORMAL ..	54D-138	BATTERY MANAGEMENT UNIT (BMU) REMOVAL AND INSTALLATION	54D-188
CODE NO. P1AXX: CMU01 BALANCER ABNORMAL	54D-139	MAIN DRIVE LITHIUM-ION BATTERY DISASSEMBLY AND ASSEMBLY.....	54D-189
CODE NO. P1AA8: LOCAL CAN (FOR TRACTION BATTERY) SIGNAL TIME-OUT	54D-140	SERVICE PROCEDURE.....	54D-189
CODE NO. P1AA9: CELL NUMBER MISMATCH	54D-146	SERVICE PROCEDURE CHECK SHEET .	54D-191
		MAIN DRAIVE LITHIUM-ION BATTERY COVER REMOVAL AND INSTALLATION	54D-194
		AIR DUCT REMOVAL AND INSTALLATION	54D-196
		PAD REMOVAL AND INSTALLATION	54D-196
		BUS BAR REMOVAL AND INSTALLATION	54D-197
		EIGHT-CELL MODULE REMOVAL AND INSTALLATION	54D-198

JFB COVER REMOVAL AND INSTALLATION	54D-202	COOLING FAN REMOVAL AND INSTALLATION	54D-211
FOUR-CELL MODULE REMOVAL AND INSTALLATION.....	54D-203	INSPECTION.....	54D-211
ELECTRIC CURRENT SENSOR REMOVAL AND INSTALLATION.....	54D-207	AIR LEAK CHECK.....	54D-211
JFB REMOVAL AND INSTALLATION	54D-207	CONTACTOR CHECK	54D-216
RESISTOR REMOVAL AND INSTALLATION	54D-209	SERVICE PLUG SWITCH INSPECTION . .	54D-217
CONTACTOR REMOVAL AND INSTALLATION	54D-210	LOCAL CAN TERMINATING RESISTOR CHECK	54D-217
		MAIN DRIVE LITHIUM-ION BATTERY ELECTRIC CURRENT SENSOR CHECK	54D-218
		RESISTOR CHECK.....	54D-218

GENERAL

M1549226500212

OUTLINE OF CHANGES

Due to the addition of Main Drive Lithium-ion Battery disassembly/assembly, the service procedure has been established. The other service procedures are the same as before.

- The DTC for the EV-ECU is changed.
- The troubleshooting of symptom procedures for the EV-ECU is changed.
- The DTC for the EMCU is changed.
- The DTC for the BMU is changed.
- The on-vehicle service of the BMU is changed.
- The Main Drive Lithium-ion Battery disassembly/assembly is added.
- The Main Drive Lithium-ion Battery inspection is added.

SERVICE PRECAUTION

M1549406100012

Disassembly, assembly and inspections of the Main Drive Lithium-ion Battery should be carried out by only specially trained mechanics. Carry out the work at the place which the rain, snow, sand, or dust will not enter. Make sure that the floor of the work place is dry (not wet). Make sure that the Main Drive Lithium-ion Battery is not wet.

PRECAUTIONS ON INSIDE OPERATION OF THE MAIN DRIVE LITHIUM-ION BATTERY

M1549403700015

⚠ DANGER

Observe the following precautions during service operations inside the Main Drive Lithium-ion Battery as they may cause an electric shock, electric leak, vehicle fires or disabled drive-away.

1. Precautions on handling high-voltage terminals

When doing any repair work in vicinity of the areas below, pay attention to the following.

Affected areas: Module terminal, bus bar, orange wiring harness and connectors, fuses, resistors and service plugs

- Touching two different terminals by bare hands simultaneously may cause burns.
- Touching two different terminals simultaneously by a rubber or metal object may cause fires due to a short circuit.
- Touching a terminal and its surrounding area by bare hands simultaneously may cause electric shocks or burns. (by leakage of electricity)
- Touching a terminal and its surrounding area simultaneously by a rubber or metal object may cause fires due to a short circuit. (by leakage of electricity)

NOTE: In the descriptions above, "rubber" indicates a part containing graphite such as tires or coolant hoses. Isolated rubber products are not included.

- A contaminated or damaged terminal seating will increase contact resistance. This will cause vehicle fires due to overheat.
- A contaminated or damaged terminal thread will decrease terminal contact pressure. This will cause vehicle fires due to overheat.

NOTE: Check not only that a terminal nut is seated securely, but also that terminal contact surfaces are seated securely.

2. Precautions on other operations

How to handle tools

- Electric shocks, burns or fires may be caused if a tool, which is put or left on a component, contacts a high-voltage circuit.

How to handle metal parts

- If a metal part drops inside the Main Drive Lithium-ion Battery, leakage of electricity or short circuit may cause vehicle fires.

How to handle waterproof seals

- A deteriorated waterproof seal may cause water ingress inside the Main Drive Lithium-ion Battery. This will cause leakage of electricity, thus disabling the vehicle drive-away.

EV-ECU

DIAGNOSTIC TROUBLE CODE CHART

M1549200600479

DTC	Diagnostic item	Reference page
P0A0A	Inter lock SW	P.54D-6
P0AA1	Main contactor P weld	P.54D-9
P0AA4	Main contactor N weld	P.54D-14
P0ADB	Main contactor P circuit low	P.54D-18
P0ADF	Main contactor N circuit low	
P0AE2	Pre-charge contactor weld	P.54D-21
P0AE6	Pre-charge contactor circuit low	P.54D-26
P0AE7	Pre-charge contactor circuit HI	
P101B	Quick CHG. contactor P weld	P.54D-29
P101C	Quick CHG. contactor N weld	P.54D-32
P1A15	High voltage circuit (1)	P.54D-36
P1A17	High voltage circuit (3)	P.54D-47
P1AFA	Quick Charger READY timeout	P.54D-52
P1AFB	Quick charging time over	P.54D-57
P1AFC	Quick charging current	P.54D-60
P1AFD	Quick charging voltage	P.54D-62
P1B01	Quick Charger vehicle error	P.54D-66
P1B04	Charging Cell MAX voltage high	P.54D-71
P1B05	Charging Cell MIN. voltage low	
P1B06	Charging Cell MAX temp. high	P.54D-73
P1B07	Charging total battery voltage	P.54D-71
P1B0C	On board charging over current	P.54D-74
P1B0D	Quick charging over current	P.54D-76
P1B21	OBC output current	P.54D-74
P1B72	Quick Charger charging current 1	P.54D-78

DTC	Diagnostic item	Reference page
P1B73	Quick Charger charging current 2	P.54D-81
P1B74	Quick Charger dis-CHG. current 1	P.54D-83
P1B75	Quick Charger dis-CHG. current 2	P.54D-86
P1B76	Quick Charger dis-CHG. current 3	P.54D-89
P1B77	Quick Charger dis-CHG. current 4	P.54D-91
P1B78	Quick Charger received current	P.54D-94
U111C	BMU CAN timeout	P.54D-97

DIAGNOSTIC TROUBLE CODE PROCEDURES

DTC P0A0A Inter Lock SW

OPERATION

The service plug switch in the main drive lithium-ion battery sets the service plug state to the EV-ECU by means of the service plug switch signal.

DTC SET CONDITION

- When the signal of the service plug switch in the main drive lithium-ion battery is turned off, DTC P0A0A will be set.

PROBABLE CAUSES

- Damaged wiring harness or connector(s)
- Disengagement of the service plug in the main drive lithium-ion battery
- Malfunction of the service plug switch
- Malfunction of the EV-ECU

DIAGNOSIS

STEP 1. Measure the voltage at C-26 main drive lithium-ion battery connector

- Disconnect the C-26 main drive lithium-ion battery connector, and measure the voltage at the control wiring harness side.
- Turn the electric motor switch to the ON position.
- Measure the voltage between the C-26 main drive lithium-ion battery connector terminal No.3 and the body ground.

OK: Battery voltage

Q: Is the check result normal?

YES : Go to Step 4.

NO : Go to Step 2.

STEP 2. Connector check: C-26 main drive lithium-ion battery connector, C-110 EV-ECU connector

Q: Is the check result normal?

YES : Go to Step 3.

NO : Repair the damaged connector.

STEP 3. Check the wiring harness between C-26 main drive lithium-ion battery connector terminal No.3 and C-110 EV-ECU connector terminal No.98.

Check the power supply line for open circuit.

Q: Is the check result normal?

YES : Intermittent malfunction (Refer to GROUP 00 – How to Use Troubleshooting/Inspection Service Points – How to Cope with Intermittent Malfunction).

NO : Repair the wiring harness.

STEP 4. Connector check: C-21 main drive lithium-ion battery connector

Q: Is the check result normal?

YES : Go to Step 5.

NO : Repair the damaged connector.

STEP 5. Check the wiring harness between C-21 main drive lithium-ion battery connector terminal No.4 and C-110 EV-ECU connector terminal No.74

Check the signal lines for open circuit.

Q: Is the check result normal?

YES : Go to Step 6.

NO : Repair the wiring harness.

STEP 6. Measure the resistance at C-21, C-26 main drive lithium-ion battery connector.

Check the service plug switch in the main drive lithium-ion battery (Refer to [P.54D-184](#)).

Q: Is the check result normal?

YES : Go to Step 10.

NO : Go to Step 7.

STEP 7. Connector check: C-21, C-26 main drive lithium-ion battery connector, service plug switch connector

Removal the main drive lithium-ion battery cover (Refer to [P.54D-194](#)).

Q: Is the check result normal?

YES : Go to Step 8.

NO : Repair the damaged connector.

STEP 8. Check the wiring harness between C-26 main drive lithium-ion battery connector terminal No. 3 and service plug connector terminal No. 1, C-21 main drive lithium-ion battery connector terminal No. 4 and service plug switch connector terminal No. 2

NOTE: Before checking harness, check intermediate connector (1) terminal No. 4 and No. 11 of power supply line, and repair if necessary.

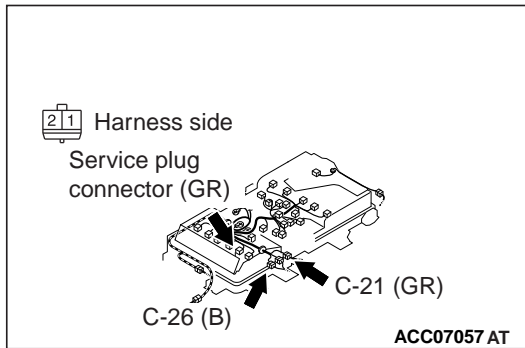

Check power supply line or out signal line for open circuit.

Q: Is the check result normal?

YES : Go to Step 9.

NO : Repair the wiring harness.

STEP 9. Check the service plug switch in main drive lithium-ion battery

- (1) Removal the service plug switch in main drive lithium-ion battery (Refer to [P.54D-189](#)).
- (2) Check the service plug switch in main drive lithium-ion battery (Refer to [P.54D-217](#)).

Q: Is the check result normal?

YES : Intermittent malfunction (Refer to GROUP 00 – How to Use Troubleshooting/Inspection Service Points – How to Cope with Intermittent Malfunctions).

NO : Replace the service plug switch in main drive lithium-ion battery (Refer to [P.54D-197](#)).

STEP 10. Check whether the DTC is set again.

Check again if the DTC is set in the EV-ECU.

- (1) Erase the DTC.
- (2) Set the electric motor switch from the LOCK (OFF) position to the ON position.
- (3) Check if the DTC is set.

Q: Is DTC P0A0A set?

YES : Replace the EV-ECU. Then go to Step 11.

NO : Intermittent malfunction (Refer to GROUP 00 – How to Use Troubleshooting/Inspection Service Points – How to Cope with Intermittent Malfunction).

STEP 11. Check whether the DTC is set again.

Check again if the DTC is set in the EV-ECU.

- (1) Erase the DTC.
- (2) Set the electric motor switch from the LOCK (OFF) position to the ON position.
- (3) Check if the DTC is set.

Q: Is DTC P0A0A set?

YES : Return to Step 1.

NO : The diagnosis is complete.

DTC P0AA1 Main Contactor P Weld

⚠ DANGER

- ***When servicing the high voltage system parts, always shut off the high voltage by removing the service plug (Refer to GROUP 00 – Precautions Before Service, Precautions on how to use the high-voltage vehicle).***
- ***When servicing the high voltage system parts, always wear the protective equipment or armor to measure the high voltage (Refer to GROUP 00 – Precautions Before Service, Precautions on how to use the high-voltage vehicle).***

⚠ CAUTION

If there is any problem in the CAN bus lines, an incorrect DTC may be set. Prior to this diagnosis, always diagnose the CAN bus lines (Refer to GROUP 54C – CAN Bus Diagnostics Table).

OPERATION

- The main contactors (+) and (–) and the charging contactor inside the main drive lithium-ion battery, which are controlled by the EV-ECU, activate and deactivate the high-voltage circuit. The EV-ECU monitors the voltage in the smoothing condenser in the EMCU.

DTC SET CONDITION

- If a seizure of the main contactor (+) or charging contactor is determined when the high-voltage circuit is shut down, DTC P0AA1 will be set.

NOTE: This DTC is set as a current trouble only. Therefore, follow the troubleshooting steps for the current trouble.

PROBABLE CAUSES

- Damaged wiring harness or connector(s)
- Malfunction of the main contactor (+) in the main drive lithium-ion battery
- Malfunction of the charging contactor in the main drive lithium-ion battery
- Malfunction of the EV-ECU
- Malfunction of the EV water PTC heater
- Malfunction of the A/C control unit
- Malfunction of the onboard charger/DC-DC converter
- Malfunction of the EMCU
- Malfunction of the A/C compressor

DIAGNOSIS

STEP 1. Using scan tool MB991958, diagnose the CAN bus lines.

Use the scan tool to diagnose the CAN bus lines.

Q: Is the check result normal?

YES : Go to Step 3.

NO : Repair the CAN bus line (Refer to GROUP 54C – Troubleshooting). Then go to Step 2.

STEP 2. DTC recheck after resetting CAN bus lines

Check again if DTC P0AA1 is set in the EV-ECU.

- (1) Set the electric motor switch from the LOCK (OFF) position to the ON, and then to the START position temporarily.
- (2) Erase the DTC.
- (3) After the electric motor switch from the LOCK (OFF) position, reset the electric motor switch from the LOCK (OFF) position to the ON position.
- (4) Check if the DTC is set.

Q: Is DTC set?

YES : Go to Step 3.

NO : This diagnosis is complete.

STEP 3. Use scan tool MB991958 to confirm a DTC of other systems.

Check if DTC P0AE7 is set in the EV-ECU.

Q: Is the DTC set?

YES : Carry out troubleshooting for the DTC.

NO : Go to Step 4.

STEP 4. Connector check: C-22 main drive lithium-ion battery connector, C-111 EV-ECU connector

Q: Is the check result normal?

YES : Go to Step 5.

NO : Repair the damaged connector.

STEP 5. Check the wiring harness between C-111 EV-ECU connector terminal No.107 and C-22 main drive lithium-ion battery connector terminal No.3

Check the signal lines for short to power supply.

Q: Is the check result normal?

YES : Go to Step 6.

NO : Repair the wiring harness.

STEP 6. Voltage measurement at G-19 high-voltage, service plug connector

⚠ DANGER

- **When high voltage system components are serviced, be sure to remove service plug to shut down high voltage (Refer to GROUP 00 – Precautions Before service, Precautions on how to use the high-voltage vehicle).**
- **When removing service plug, wear the specified protective equipment.**

(1) Using a high voltage multimeter, measure the high voltage between the G-19 connection terminal and service plug connection forward terminal.

OK: Approximately 0 V

Q: Is the check result normal?

YES : Go to Step 10.

NO : Go to Step 7.

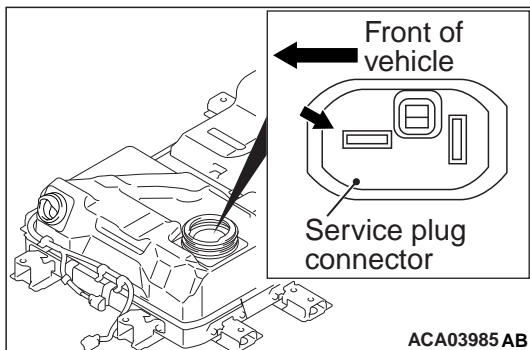

STEP 7. Connector check: C-22 main drive lithium-ion battery connector, main contactor (+) connector

Removal the main drive lithium-ion battery cover (Refer to [P.54D-194](#)).

Q: Is the check result normal?

YES : Go to Step 8.

NO : Repair the damaged connector.

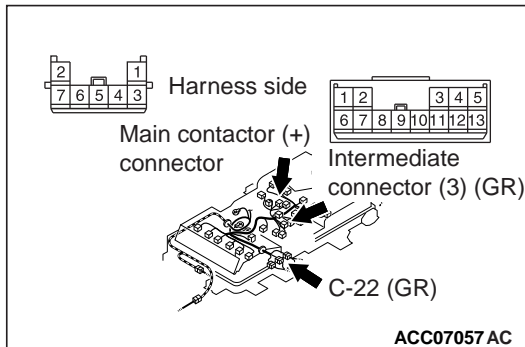

STEP 8. Check the wiring harness between C-22 main drive lithium-ion battery connector terminal No. 3 and main contactor (+) connector terminal No. 3, C-22 main drive lithium-ion battery connector terminal No. 5 and main contactor (+) connector terminal No. 1

NOTE: Before checking harness, check intermediate connector (3) terminal No. 4 and No. 13 of ground line, and repair if necessary.

Check out signal line and ground line for open circuit.

Q: Is the check result normal?

YES : Go to Step 9.

NO : Repair the wiring harness.

STEP 9. Check the main contactor (+) in main drive lithium-ion battery

- (1) Removal the main contactor (+) in main drive lithium-ion battery (Refer to [P.54D-189](#)).
- (2) Check the main contactor (+) in main drive lithium-ion battery (Refer to [P.54D-216](#)).

Q: Is the check result normal?

YES : Intermittent malfunction (Refer to GROUP 00 – How to Use Troubleshooting/Inspection Service Points – How to Cope with Intermittent Malfunctions).

NO : Replace the main contactor (+) in main drive lithium-ion battery (Refer to [P.54D-210](#)). Then go to Step 10.

STEP 10. Use scan tool MB991958 to confirm a DTC of other systems.

Check if the DTC except P0AE7 or P1A16 is set in the EV-ECU.

Q: Is the DTC set?

YES : Carry out troubleshooting for the DTC.

NO : Go to Step 11.

STEP 11. Use scan tool MB991958 to confirm a DTC of other systems.

Check if the DTC is set in the A/C control unit.

Q: Is the DTC set?

YES : Carry out troubleshooting for the DTC (Refer to GROUP 55 – Troubleshooting).

NO : Go to Step 12.

STEP 12. Measure the resistance of the G-21 EV water PTC heater connector** DANGER**

- ***When high voltage system components are serviced, be sure to remove service plug to shut down high voltage (Refer to GROUP 00 – Precautions Before service, Precautions on how to use the high-voltage vehicle).***
 - ***When removing service plug, wear the specified protective equipment.***
- (1) Remove the service plug.
 - (2) Disconnect the EV water PTC heater connector.
 - (3) Measure it on the resistance at the EV water PTC heater side.
 - (4) Measure the resistance between the G-21 EV water PTC heater connector terminal No.1 and No.2.

OK: 1 MΩ or more**Q: Is the check result normal?****YES :** Go to Step 13.**NO :** Check the high-voltage fuse No.3 (Refer to [P.54D-186](#)). Replace the EV water PTC heater (Refer to GROUP 55 – EV Water PTC Heater).

STEP 13. Measure the resistance at A-113 EV water PTC heater connector

- (1) Disconnect the A-113 EV water PTC heater connector and measure it on the resistance at the EV water PTC heater side.
- (2) Measure the resistance between the A-113 EV water PTC heater connector terminal No.3, 4, 5 and the body ground.

OK: No continuity**Q: Is the check result normal?****YES :** Go to Step 14.**NO :** Replace the EV water PTC heater (Refer to GROUP 55 – EV Water PTC Heater).

STEP 14. Measure the resistance at A-113 EV water PTC heater connector

- (1) Disconnect the A-113 EV water PTC heater connector and measure it on the resistance at the wiring harness side.
- (2) Measure the resistance between the A-113 EV water PTC heater connector terminal No.3, 4, 5 and the body ground.

OK: No continuity**Q: Is the check result normal?****YES :** Go to Step 17.**NO :** Go to Step 15.

STEP 15. Connector check: A-113 EV water PTC heater connector, B-01 intermediate connector, C-113 A/C control unit connector

Q: Is the check result normal?

YES : Go to Step 16.

NO : Repair the damaged connector.

STEP 16. Check the wiring harness between A-113 EV water PTC heater connector terminal No.3, 4, 5 and C-113 A/C control unit connector terminal No.34, 35, 36

Check the signal line for short circuit.

Q: Is the check result normal?

YES : Replace the A/C control unit (Refer to GROUP 55 – A/C Control Unit).

NO : Repair the wiring harness.

STEP 17. Check whether the DTC is set again.

Check again if the DTC is set in the EV-ECU.

- (1) Set the electric motor switch from the LOCK (OFF) position to the ON, and then to the START position temporarily.
- (2) Erase the DTC.
- (3) After the electric motor switch from the LOCK (OFF) position, reset the electric motor switch from the LOCK (OFF) position to the ON position.
- (4) Check if the DTC is set.

Q: Is DTC P0AA1 set?

YES : Replace the EV-ECU. Then go to Step 18.

NO : Intermittent malfunction (Refer to GROUP 00 – How to Use Troubleshooting/Inspection Service Points – How to Cope with Intermittent Malfunction).

STEP 118. Check whether the DTC is set again.

Check again if the DTC is set in the EV-ECU.

- (1) Set the electric motor switch from the LOCK (OFF) position to the ON, and then to the START position temporarily.
- (2) Erase the DTC.
- (3) After the electric motor switch from the LOCK (OFF) position, reset the electric motor switch from the LOCK (OFF) position to the ON position.
- (4) Check if the DTC is set.

Q: Is DTC P0AA1 set?

YES : Return to Step 1.

NO : The diagnosis is complete.

DTC P0AA4 Main Contactor N Weld

⚠ DANGER

- *When servicing the high voltage system parts, always shut off the high voltage by removing the service plug (Refer to GROUP 00 – Precautions Before Service, Precautions on how to use the high-voltage vehicle).*
- *When servicing the high voltage system parts, always wear the protective equipment or armor to measure the high voltage (Refer to GROUP 00 – Precautions Before Service, Precautions on how to use the high-voltage vehicle).*

⚠ CAUTION

If there is any problem in the CAN bus lines, an incorrect DTC may be set. Prior to this diagnosis, always diagnose the CAN bus lines (Refer to GROUP 54C – CAN Bus Diagnostics Table).

OPERATION

- The main contactors (+) and (–) and the charging contactor inside the main drive lithium-ion battery, which are controlled by the EV-ECU, activate and deactivate the high-voltage circuit. The EV-ECU monitors the voltage in the smoothing condenser in the EMCU.

DTC SET CONDITION

- If a seizure of the main contactor (–) is determined when the high-voltage circuit is activated, DTC P0AA4 will be set.

PROBABLE CAUSES

- Damaged wiring harness or connector(s)
- Malfunction of the main contactor (–) in the main drive lithium-ion battery
- Malfunction of the EV-ECU
- Malfunction of the EV water PTC heater
- Malfunction of the A/C control unit
- Malfunction of the onboard charger/DC-DC converter
- Malfunction of the EMCU
- Malfunction of the A/C compressor

DIAGNOSIS

STEP 1. Using scan tool MB991958, diagnose the CAN bus lines.

Use the scan tool to diagnose the CAN bus lines.

Q: Is the check result normal?

YES : Go to Step 3.

NO : Repair the CAN bus line (Refer to GROUP 54C – Troubleshooting). Then go to Step 2.

STEP 2. DTC recheck after resetting CAN bus lines

Check again if DTC P0AA4 is set in the EV-ECU.

(1) Erase the DTC.

(2) Set the electric motor switch from the LOCK (OFF) position to the ON, and then to the START position temporarily.

(3) After the electric motor switch from the LOCK (OFF) position, reset the electric motor switch from the LOCK (OFF) position to the ON position.

(4) Check if the DTC is set.

Q: Is DTC set?

YES : Go to Step 3.

NO : This diagnosis is complete.

STEP 3. Connector check: C-21 main drive lithium-ion battery connector, C-111 EV-ECU connector

Q: Is the check result normal?

YES : Go to Step 4.

NO : Repair the damaged connector.

STEP 4. Check the wiring harness between C-111 EV-ECU connector terminal No.106 and C-21 main drive lithium-ion battery connector terminal No.5

Check the signal lines for short to power supply.

Q: Is the check result normal?

YES : Go to Step 5.

NO : Repair the wiring harness.

STEP 5. Voltage measurement at G-18 high-voltage, service plug connector

⚠ DANGER

- **When high voltage system components are serviced, be sure to remove service plug to shut down high voltage (Refer to GROUP 00 – Precautions Before service, Precautions on how to use the high-voltage vehicle).**
- **When removing service plug, wear the specified protective equipment.**

(1) Using a high voltage multimeter, measure the high voltage between the G-18 connection terminal and service plug connection backward terminal.

OK: Approximately 0 V

Q: Is the check result normal?

YES : Go to Step 9.

NO : Go to Step 6.

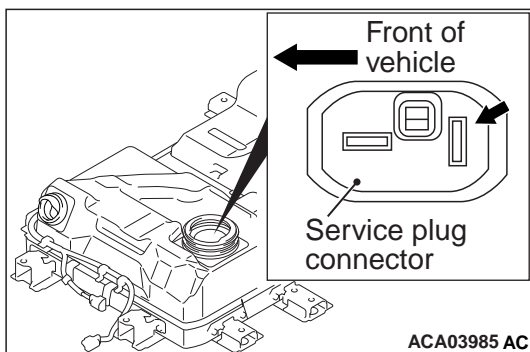

STEP 6. Connector check: C-21, C-22 main drive lithium-ion battery connector, main contactor (-) connector

Removal the main drive lithium-ion battery cover (Refer to P.54D-194).

Q: Is the check result normal?

YES : Go to Step 7.

NO : Repair the damaged connector.

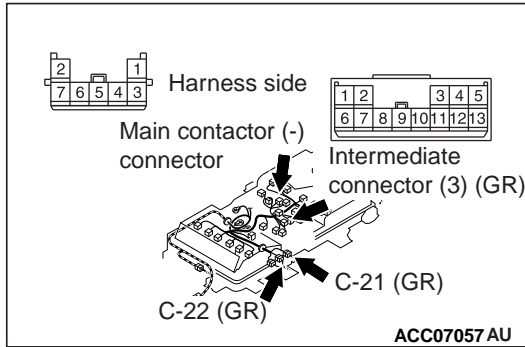

STEP 7. Check the wiring harness between C-21 main drive lithium-ion battery connector terminal No. 5 and main contactor (-) connector terminal No. 7, C-22 main drive lithium-ion battery connector terminal No. 5 and main contactor (-) connector terminal No. 2

NOTE: Before checking harness, check intermediate connector (3) terminal No. 4 and No. 12 of ground line, and repair if necessary.

Check out signal line and ground line for open circuit.

Q: Is the check result normal?

YES : Go to Step 8.

NO : Repair the wiring harness.

STEP 8. Check the main contactor (-) in main drive lithium-ion battery

- (1) Removal the main contactor (-) in main drive lithium-ion battery (Refer to [P.54D-189](#)).
- (2) Check the main contactor (-) in main drive lithium-ion battery (Refer to [P.54D-216](#)).

Q: Is the check result normal?

YES : Intermittent malfunction (Refer to GROUP 00 – How to Use Troubleshooting/Inspection Service Points – How to Cope with Intermittent Malfunctions).

NO : Replace the main contactor (-) in main drive lithium-ion battery (Refer to [P.54D-210](#)). Then go to Step 10.

STEP 9. Use scan tool MB991958 to confirm a DTC of other systems.

Check if the DTC except P0AE7 or P1A16 is set in the EV-ECU.

Q: Is the DTC set?

YES : Carry out troubleshooting for the diagnostic trouble code.

NO : Go to Step 10.

STEP 10. Use scan tool MB991958 to confirm a DTC of other systems.

Check if the DTC is set in the A/C control unit.

Q: Is the DTC set?

YES : Carry out troubleshooting for the DTC (Refer to GROUP 55 – Troubleshooting).

NO : Go to Step 11.

STEP 11. Measure the resistance of the G-21 EV water PTC heater connector

 DANGER

- ***When high voltage system components are serviced, be sure to remove service plug to shut down high voltage (Refer to GROUP 00 – Precautions Before Service, Precautions on how to use the high-voltage vehicle).***
- ***When removing service plug, wear the specified protective equipment.***

- (1) Remove the service plug.
- (2) Disconnect the G-21 EV water PTC heater connector.
- (3) Measure it on the resistance at the EV water PTC heater side.
- (4) Measure the resistance between the G-21 EV water PTC heater connector terminal No.1 and No.2.

OK: 1 MΩ or more

Q: Is the check result normal?

YES : Go to Step 12.

NO : Check the high-voltage fuse No.3 (Refer to [P.54D-186](#)). Replace the EV water PTC heater (Refer to GROUP 55 – EV Water PTC Heater).

STEP 12. Measure the resistance at A-113 EV water PTC heater connector

- (1) Disconnect the A-113 EV water PTC heater connector and measure it on the resistance at the EV water PTC heater side.
- (2) Measure the resistance between the A-113 EV water PTC heater connector terminal No.3, 4, 5 and the body ground.

OK: No continuity

Q: Is the check result normal?

YES : Go to Step 13.

NO : Replace the EV water PTC heater (Refer to GROUP 55 – EV Water PTC Heater).

STEP 13. Measure the resistance at A-113 EV water PTC heater connector

- (1) Disconnect the A-113 EV water PTC heater connector and measure it on the resistance at the wiring harness side.
- (2) Measure the resistance between the A-113 EV water PTC heater connector terminal No.3, 4, 5 and the body ground.

OK: No continuity

Q: Is the check result normal?

YES : Go to Step 16.

NO : Go to Step 14.

STEP 14. Connector check: A-113 EV water PTC heater connector, B-01 intermediate connector, C-113 A/C control unit connector

Q: Is the check result normal?

YES : Go to Step 15.

NO : Repair the damaged connector.

STEP 15. Check the wiring harness between A-113 EV water PTC heater connector terminal No.3, 4, 5 and C-113 A/C control unit connector terminal No.34, 35, 36

Check the signal line for short circuit.

Q: Is the check result normal?

YES : Replace the A/C control unit (Refer to GROUP 55 – A/C Control Unit).

NO : Repair the wiring harness.

STEP 16. Check whether the DTC is set again.

Check again if the DTC is set in the EV-ECU.

(1) Erase the DTC.

(2) Set the electric motor switch from the LOCK (OFF) position to the ON, and then to the START position temporarily.

(3) After the electric motor switch from the LOCK (OFF) position, reset the electric motor switch from the LOCK (OFF) position to the ON position.

(4) Check if the DTC is set.

Q: Is DTC P0AA4 set?

YES : Replace the EV-ECU. Then go to Step 17.

NO : Intermittent malfunction (Refer to GROUP 00 – How to Use Troubleshooting/Inspection Service Points, How to Cope with Intermittent Malfunction).

STEP 17. Check whether the DTC is set again.

Check again if the DTC is set in the EV-ECU.

(1) Erase the DTC.

(2) Set the electric motor switch from the LOCK (OFF) position to the ON, and then to the START position temporarily.

(3) After the electric motor switch from the LOCK (OFF) position, reset the electric motor switch from the LOCK (OFF) position to the ON position.

(4) Check if the DTC is set.

Q: Is DTC P0AA4 set?

YES : Return to Step 1.

NO : The diagnosis is complete.

DTC P0ADB Main Contactor P Circuit Low
DTC P0ADF Main Contactor N Circuit Low

OPERATION

The main contactors (+) and (-) in the main drive lithium-ion battery are controlled by the EV-ECU.

DTC SET CONDITIONS

- When the excitation circuit monitor of the main contactor (+) in the main drive lithium-ion battery is off while the main contactor (+) in the main drive lithium-ion battery ON command is underway, DTC P0ADB will be set.

- When the excitation circuit monitor of the main contactor (-) in the main drive lithium-ion battery is off while the main contactor (-) in the main drive lithium-ion battery ON command is underway, DTC P0ADF will be set.

PROBABLE CAUSES

- Damaged wiring harness or connector(s)
- Malfunction of the main contactors (+) or (-) in the main drive lithium-ion battery
- Malfunction of the EV-ECU

DIAGNOSIS

STEP 1. Connector check: C-21, C-22 main drive lithium-ion battery connector, C-111 EV-ECU connector

Q: Is the check result normal?

YES : Go to Step 2.

NO : Repair the damaged connector.

STEP 2. Check the wiring harness between C-111 EV-ECU connector terminal No.106, 107 and C-21 main drive lithium-ion battery connector terminal No.5, C-22 main drive lithium-ion battery connector terminal No.3

Check the signal lines for open circuit and short to ground.

Q: Is the check result normal?

YES : Go to Step 3.

NO : Repair the wiring harness.

STEP 3. Measure the resistance at C-21, C-22 main drive lithium-ion battery connector

Check the main contactor (+) or (-) in the main drive lithium-ion battery (Refer to [P.54D-181](#)).

Q: Is the check result normal?

YES : Go to Step 8.

NO : Go to Step 4.

STEP 4. Connector check: C-21, C-22 main drive lithium-ion battery connector, main contactor (+), (-) connector

Removal the main drive lithium-ion battery cover (Refer to [P.54D-194](#)).

Q: Is the check result normal?

YES : Go to Step 5.

NO : Repair the damaged connector.

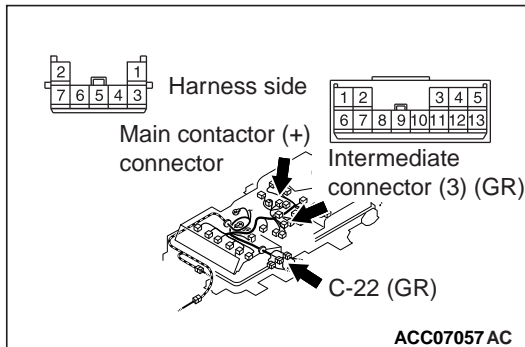

STEP 5. Check the wiring harness between C-22 main drive lithium-ion battery connector terminal No. 3 and main contactor (+) connector terminal No. 3, C-22 main drive lithium-ion battery connector terminal No. 5 and main contactor (+) connector terminal No. 1

NOTE: Before checking harness, check intermediate connector (3) terminal No. 4 and No. 13 of ground line, and repair if necessary.

Check out signal line and ground line for open circuit.

Q: Is the check result normal?

YES : Go to Step 6.

NO : Repair the wiring harness.

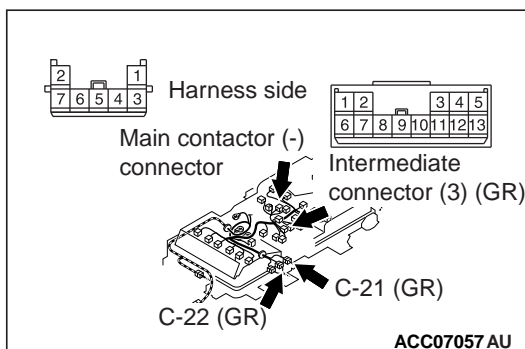

STEP 6. Check the wiring harness between C-21 main drive lithium-ion battery connector terminal No. 5 and main contactor (-) connector terminal No. 7, C-22 main drive lithium-ion battery connector terminal No. 5 and main contactor (-) connector terminal No. 2

NOTE: Before checking harness, check intermediate connector (3) terminal No. 4 and No. 12 of ground line, and repair if necessary.

Check out signal line and ground line for open circuit.

Q: Is the check result normal?

YES : Go to Step 7.

NO : Repair the wiring harness.

STEP 7. Check the main contactor (+), (-) in main drive lithium-ion battery

(1) Removal the main contactor (+), (-) in main drive lithium-ion battery (Refer to [P.54D-189](#)).

(2) Check the main contactor (+), (-) in main drive lithium-ion battery (Refer to [P.54D-216](#)).

Q: Is the check result normal?

YES : Intermittent malfunction (Refer to GROUP 00 – How to Use Troubleshooting/Inspection Service Points – How to Cope with Intermittent Malfunctions).

NO : Replace the main contactor (+), (-) in main drive lithium-ion battery (Refer to [P.54D-210](#)). Then go to Step 9.

STEP 8. Check whether the DTC is set again.

Check again if the DTC is set in the EV-ECU.

- (1) Erase the DTC.
- (2) Set the electric motor switch from the LOCK (OFF) position to the ON, and then to the START position temporarily.
- (3) After the electric motor switch from the LOCK (OFF) position, reset the electric motor switch from the LOCK (OFF) position to the ON position.
- (4) Check if the DTC is set.

Q: Is DTC P0ADB or D0ADF set?

YES : Replace the EV-ECU. Then go to Step 9.

NO : Intermittent malfunction (Refer to GROUP 00 – How to Use Troubleshooting/Inspection Service Points – How to Cope with Intermittent Malfunction).

STEP 9. Check whether the DTC is set again.

Check again if the DTC is set in the EV-ECU.

- (1) Erase the DTC.
- (2) Set the electric motor switch from the LOCK (OFF) position to the ON, and then to the START position temporarily.
- (3) After the electric motor switch from the LOCK (OFF) position, reset the electric motor switch from the LOCK (OFF) position to the ON position.
- (4) Check if the DTC is set.

Q: Is DTC P0ADB or D0ADF set?

YES : Return to Step 1.

NO : The diagnosis is complete.

DTC P0AE2 Pre-charging Contactor Weld** DANGER**

- *When servicing the high voltage system parts, always shut off the high voltage by removing the service plug (Refer to GROUP 00 – Precautions Before Service, Precautions on how to use the high-voltage vehicle).*
- *When servicing the high voltage system parts, always wear the protective equipment or armor to measure the high voltage (Refer to GROUP 00 – Precautions Before Service, Precautions on how to use the high-voltage vehicle).*

 CAUTION

If there is any problem in the CAN bus lines, an incorrect DTC may be set. Prior to this diagnosis, always diagnose the CAN bus lines (Refer to GROUP 54C – CAN Bus Diagnostics Table).

OPERATION

- The main contactors (+) and (–) and the charging contactor inside the main drive lithium-ion battery, which are controlled by the EV-ECU, activate and deactivate the high-voltage circuit. The EV-ECU monitors the voltage in the smoothing condenser in the EMCU.

DTC SET CONDITION

- If a seizure of the charging contactor or main contactor (+) is determined when the high-voltage circuit is activated, diagnostic trouble code No. P0AE2 will be set.

PROBABLE CAUSES

- Damaged wiring harness or connector(s)
- Malfunction of the charging contactor in the main drive lithium-ion battery
- Malfunction of the EV-ECU
- Malfunction of the EV water PTC heater

- Malfunction of the A/C compressor
- Malfunction of the onboard charger/DC-DC converter
- Malfunction of the EMCU

DIAGNOSIS

STEP 1. Using scan tool MB991958, diagnose the CAN bus lines

Use the scan tool to diagnose the CAN bus lines.

Q: Is the check result normal?

YES : Go to Step 3.

NO : Repair the CAN bus line (Refer to GROUP 54C – Troubleshooting). Then go to Step 2.

STEP 2. DTC recheck after resetting CAN bus lines

Check again if DTC P0AE2 is set in the EV-ECU.

(1) Erase the DTC.

(2) Set the electric motor switch from the LOCK (OFF) position to the ON, and then to the START position temporarily.

(3) After the electric motor switch from the LOCK (OFF) position, reset the electric motor switch from the LOCK (OFF) position to the ON position.

(4) Check if the DTC is set.

Q: Is DTC set?

YES : Go to Step 3.

NO : This diagnosis is complete.

STEP 3. Use scan tool MB991958 to confirm a DTC of other systems.

Check if DTC P0AE7 is set in the EV-ECU.

Q: Is the DTC set?

YES : Carry out troubleshooting for the DTC.

NO : Go to Step 4.

STEP 4. Connector check: C-21, C-22 main drive lithium-ion battery connector, C-111 EV-ECU connector

Q: Is the check result normal?

YES : Go to Step 5.

NO : Repair the damaged connector.

STEP 5. Check the wiring harness between C-111 EV-ECU connector terminal No.105 and C-21 main drive lithium-ion battery connector terminal No.6

Check the output lines for open circuit and short to ground.

Q: Is the check result normal?

YES : Go to Step 6.

NO : Repair the wiring harness.

STEP 6. Voltage measurement at G-19 high-voltage connector, service plug

⚠ DANGER

- **When high voltage system components are serviced, be sure to remove service plug to shut down high voltage (Refer to GROUP 00 – Precautions Before Service, Precautions on how to use the high-voltage vehicle).**
- **When removing service plug, wear the specified protective equipment.**

(1) Using a high voltage multimeter, measure the high voltage between the G-19 connection terminal and service plug forward terminal.

OK: Approximately 0 V

Q: Is the check result normal?

YES : Go to Step 10.

NO : Go to Step 7.

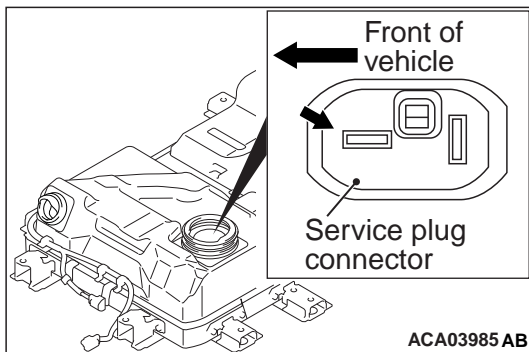

STEP 7. Connector check: C-21, C-22 main drive lithium-ion battery connector, charging contactor connector
Removal of the main drive lithium-ion battery cover (Refer to P.54D-194).

Q: Is the check result normal?

YES : Go to Step 8.

NO : Repair the damaged connector.

STEP 8. Check the wiring harness between C-21 main drive lithium-ion battery connector terminal No. 6 and charging contactor connector terminal No. 4, C-22 main drive lithium-ion battery connector terminal No. 5 and charging contactor connector terminal No. 6

NOTE: Before checking harness, check intermediate connector (3) terminal No. 4 and No. 11 of ground line, and repair if necessary.

Check out signal line and ground line for open circuit.

Q: Is the check result normal?

YES : Go to Step 9.

NO : Repair the wiring harness.

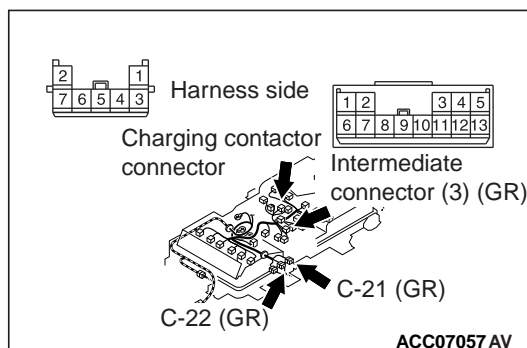

STEP 9. Check the charging contactor in main drive lithium-ion battery

- (1) Removal the charging contactor in main drive lithium-ion battery (Refer to [P.54D-189](#)).
- (2) Check the charging contactor in main drive lithium-ion battery (Refer to [P.54D-216](#)).

Q: Is the check result normal?

YES : Intermittent malfunction (Refer to GROUP 00 – How to Use Troubleshooting/Inspection Service Points – How to Cope with Intermittent Malfunctions).

NO : Replace the charging contactor in main drive lithium-ion battery (Refer to [P.54D-210](#)). Then go to Step 11.

STEP 10. Use scan tool MB991958 to confirm a DTC of other systems.

Check if the DTC except No. P0AE7 or P1A16 is set in the EV-ECU.

Q: Is the DTC set?

YES : Carry out troubleshooting for the diagnostic trouble code.

NO : Go to Step 11.

STEP 11. Use scan tool MB991958 to confirm a DTC of other systems.

Check if the DTC is set in the A/C control unit.

Q: Is the DTC set?

YES : Carry out troubleshooting for the diagnostic trouble code (Refer to GROUP 55 – Troubleshooting).

NO : Go to Step 12.

STEP 12. Measure the resistance of the G-21 EV water PTC heater connector

 DANGER

- ***When high voltage system components are serviced, be sure to remove service plug to shut down high voltage (Refer to GROUP 00 – Precautions Before Service, Precautions on how to use the high-voltage vehicle).***
- ***When removing service plug, wear the specified protective equipment.***

- (1) Remove the service plug.
- (2) Disconnect the G-21 EV water PTC heater connector.
- (3) Measure it on the resistance at the EV water PTC heater side.
- (4) Measure the resistance between the G-21 EV water PTC heater connector terminal No.1 and No.2.

OK: 1 MΩ or more

Q: Is the check result normal?

YES : Go to Step 13.

NO : Check the high-voltage fuse No.3 (Refer to [P.54D-186](#)). Replace the EV water PTC heater (Refer to GROUP 55 – EV Water PTC Heater).

STEP 13. Measure the resistance at A-113 EV water PTC heater connector

- (1) Disconnect the A-113 EV water PTC heater connector and measure it on the resistance at the EV water PTC heater side.
- (2) Measure the resistance between the A-113 EV water PTC heater connector terminal No.3, 4, 5 and the body ground.

OK: No continuity

Q: Is the check result normal?

YES : Go to Step 14.

NO : Replace the EV water PTC heater (Refer to GROUP 55 – EV Water PTC Heater).

STEP 14. Measure the resistance at A-113 EV water PTC heater connector

- (1) Disconnect the A-113 EV water PTC heater connector and measure it on the resistance at the wiring harness side.
- (2) Measure the resistance between the A-113 EV water PTC heater connector terminal No.3, 4, 5 and the body ground.

OK: No continuity

Q: Is the check result normal?

YES : Go to Step 17.

NO : Go to Step 15.

STEP 15. Connector check: A-113 EV water PTC heater connector, B-01 joint connector, C-113 A/C control unit connector

Q: Is the check result normal?

YES : Go to Step 16.

NO : Repair the damaged connector.

STEP 16. Check the wiring harness between A-113 EV water PTC heater connector terminal No.3, 4, 5 and C-113 A/C control unit connector terminal No.34, 35, 36.

Check the signal line for short circuit.

Q: Is the check result normal?

YES : Replace the A/C control unit (Refer to GROUP 55 – A/C Control Unit).

NO : Repair the wiring harness.

STEP 17. Check whether the DTC is set again.

Check again if the DTC is set in the EV-ECU.

(1) Erase the DTC.

(2) Set the electric motor switch from the LOCK (OFF) position to the ON, and then to the START position temporarily.

(3) After the electric motor switch from the LOCK (OFF) position, reset the electric motor switch from the LOCK (OFF) position to the ON position.

(4) Check if the DTC is set.

Q: Is DTC P0AE2 set?

YES : Replace the EV-ECU. Then go to Step 18.

NO : Intermittent malfunction (Refer to GROUP 00 – How to Use Troubleshooting/Inspection Service Points – How to Cope with Intermittent Malfunction).

STEP 18. Check whether the DTC is set again.

Check again if the DTC is set in the EV-ECU.

(1) Erase the DTC.

(2) Set the electric motor switch from the LOCK (OFF) position to the ON, and then to the START position temporarily.

(3) After the electric motor switch from the LOCK (OFF) position, reset the electric motor switch from the LOCK (OFF) position to the ON position.

(4) Check if the DTC is set.

Q: Is DTC P0AE2 set?

YES : Return to Step 1.

NO : The diagnosis is complete.

DTC P0AE6 Pre-charge Contactor Low
DTC P0AE7 Pre-charge Contactor High

OPERATION

The charging contactor in the main drive lithium-ion battery is controlled by the EV-ECU.

DTC SET CONDITIONS

- When the excitation coil monitor of the charging contactor in the main drive lithium-ion battery is off while the charging contactor in the main drive lithium-ion battery ON command is underway, DTC P0AE6 will be set.
- When the excitation coil monitor of the charging contactor in the main drive lithium-ion battery is on while the charging contactor in the main drive lithium-ion battery OFF command is underway, DTC P0AE7 will be set.

PROBABLE CAUSES

- Damaged wiring harness or connector(s)
- Malfunction of the charging contactor in the main drive lithium-ion battery
- Malfunction of the EV-ECU

DIAGNOSIS

STEP 1. Connector check: C-21, C-22 main drive lithium-ion battery connector, C-111 EV-ECU connector

Q: Is the check result normal?

YES : Go to Step 2.

NO : Repair the damaged connector.

STEP 2. Check the wiring harness between C-111 EV-ECU connector terminal No.105 and C-21 main drive lithium-ion battery connector terminal No.6

Check the output lines for open circuit and short to ground.

Q: Is the check result normal?

YES : Go to Step 3.

NO : Repair the wiring harness.

STEP 3. Measure the resistance at C-21, C-22 main drive lithium-ion battery connector

Check the charging contactor in the main drive lithium-ion battery (Refer to [P.54D-181](#)).

Q: Is the check result normal?

YES : Go to Step 7.

NO : Go to Step 4.

STEP 4. Connector check: C-21, C-22 main drive lithium-ion battery connector, charging contactor connector

Removal the main drive lithium-ion battery cover (Refer to [P.54D-194](#)).

Q: Is the check result normal?

YES : Go to Step 5.

NO : Repair the damaged connector.

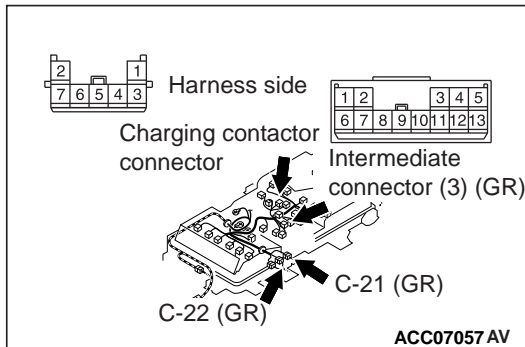

STEP 5. Check the wiring harness between C-21 main drive lithium-ion battery connector terminal No. 6 and charging contactor connector terminal No. 4, C-22 main drive lithium-ion battery connector terminal No. 5 and charging contactor connector terminal No. 6

NOTE: Before checking harness, check intermediate connector (3) terminal No. 4 and No. 11 of ground line, and repair if necessary.

Check out signal line and ground line for open circuit.

Q: Is the check result normal?

YES : Go to Step 6.

NO : Repair the wiring harness.

STEP 6. Check the charging contactor in main drive lithium-ion battery

- (1) Removal the charging contactor in main drive lithium-ion battery (Refer to [P.54D-189](#)).
- (2) Check the charging contactor in main drive lithium-ion battery (Refer to [P.54D-216](#)).

Q: Is the check result normal?

YES : Intermittent malfunction (Refer to GROUP 00 – How to Use Troubleshooting/Inspection Service Points – How to Cope with Intermittent Malfunctions).

NO : Replace the charging contactor in main drive lithium-ion battery (Refer to [P.54D-210](#)). Then go to Step 8.

STEP 7. Check whether the DTC is set again.

Check again if the DTC is set in the EV-ECU.

- (1) Erase the DTC.
- (2) Set the electric motor switch from the LOCK (OFF) position to the ON, and then to the START position temporarily.
- (3) After the electric motor switch from the LOCK (OFF) position, reset the electric motor switch from the LOCK (OFF) position to the ON position.
- (4) Check if the DTC is set.

Q: Is DTC P0AE6 or P0AE7 set?

YES : Replace the EV-ECU. Then go to Step 8.

NO : Intermittent malfunction (Refer to GROUP 00 – How to Use Troubleshooting/Inspection Service Points – How to Cope with Intermittent Malfunction).

STEP 8. Check whether the DTC is set again.

Check again if the DTC is set in the EV-ECU.

- (1) Erase the DTC.
- (2) Set the electric motor switch from the LOCK (OFF) position to the ON, and then to the START position temporarily.
- (3) After the electric motor switch from the LOCK (OFF) position, reset the electric motor switch from the LOCK (OFF) position to the ON position.
- (4) Check if the DTC is set.

Q: Is DTC P0AE6 or P0AE7 set?

YES : Return to Step 1.

NO : The diagnosis is complete.

DTC P101B Quick CHG. Contactor P Weld** DANGER**

- *When servicing the high voltage system parts, always shut off the high voltage by removing the service plug (Refer to GROUP 00 – Precautions Before Service, Precautions on how to use the high-voltage vehicle).*
- *When servicing the high voltage system parts, always wear the protective equipment or armor to measure the high voltage (Refer to GROUP 00 – Precautions Before Service, Precautions on how to use the high-voltage vehicle).*

 CAUTION

If there is any problem in the CAN bus lines, an incorrect DTC may be set. Prior to this diagnosis, always diagnose the CAN bus lines (Refer to GROUP 54C – CAN Bus Diagnostics Table).

OPERATION

The EV-ECU controls the quick charging relay (+), which energizes the coil of the quick charging contactor (+) inside the main drive lithium-ion battery, to connect or disconnect the high-voltage circuit.

DTC SET CONDITION

- The system determines whether quick charging contactor (+) is stuck when the quick charging terminates. If yes, DTC P101B will be set.

PROBABLE CAUSES

- Damaged wiring harness or connector(s)
- Malfunction of the quick charging contactor (+)
- Malfunction of the quick charging relay (+)
- Malfunction of the EV-ECU

DIAGNOSIS**STEP 1. Using scan tool MB991958, diagnose the CAN bus lines.**

Use the scan tool to diagnose the CAN bus lines.

Q: Is the check result normal?

YES : Go to Step 2.

NO : Repair the CAN bus line (Refer to GROUP 54C – Troubleshooting). Then go to Step 2.

STEP 2. Using scan tool MB991958, check data list

Check the service data associated with the quick charging contactor (+) status.

Data list

- Item No. 67: Quick charge contactor (+)

OK: Displays the OFF

Q: Is the check result normal?

YES : Go to Step 3.

NO : Carry out troubleshooting for the DTC P1019, P101A.

STEP 3. Use scan tool MB991958 to confirm a DTC of other systems.

Check if DTC P1019, P101A is set in the EV-ECU.

Q: Is the DTC set?

YES : Carry out troubleshooting for the DTC.

NO : Go to Step 4.

STEP 4. Connector check: C-21, C-22 main drive lithium-ion battery connector**Q: Is the check result normal?**

YES : Go to Step 5.

NO : Repair the damaged connector.

STEP 5. Measure the resistance at C-21, C-22 main drive lithium-ion battery connector

Check the quick charging contactor (+) in the main drive lithium-ion battery (Refer to [P.54D-181](#)).

Q: Is the check result normal?

YES : Go to Step 9.

NO : Go to Step 6.

STEP 6. Connector check: quick charging contactor connector

Removal the main drive lithium-ion battery cover (Refer to [P.54D-194](#)).

Q: Is the check result normal?

YES : Go to Step 7.

NO : Repair the damaged connector.

STEP 7. Check the wiring harness between C-21 main drive lithium-ion battery connector terminal No.11 and quick charging contactor (+) connector terminal No.1, C-22 main drive lithium-ion battery connector terminal No.5 and quick charging contactor (+) connector terminal No.3

NOTE: Before checking harness, check intermediate connector (3) terminal No.3 and No.4 of ground line, and repair if necessary.

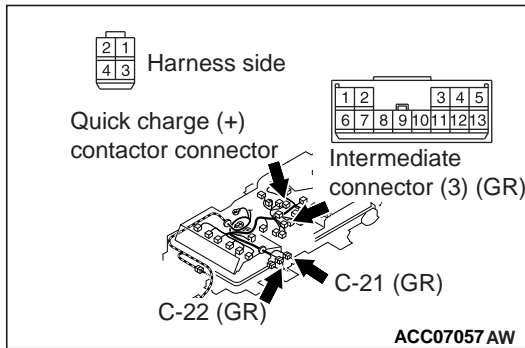

Check the signal line for short to ground.

Q: Is the check result normal?

YES : Go to Step 8.

NO : Repair the wiring harness.

STEP 8. Check the quick charging contactor (+) in main drive lithium-ion battery

- (1) Removal the quick charging contactor (+) in main drive lithium-ion battery (Refer to [P.54D-189](#)).
- (2) Check the quick charging contactor (+) in main drive lithium-ion battery (Refer to [P.54D-216](#)).

Q: Is the check result normal?

YES : Go to Step 9.

NO : Replace the quick charging contactor (+) in main drive lithium-ion battery (Refer to [P.54D-210](#)).

STEP 9. Measure the resistance between the G-01 EV charging cable (+) terminal and the G-19 main drive lithium-ion battery cable (+) terminal

⚠ DANGER

- **When high voltage system components are serviced, be sure to remove service plug to shut down high voltage (Refer to GROUP 00 – Precautions Before Service, Precautions on how to use the high-voltage vehicle).**
- **When removing service plug, wear the specified protective equipment.**

- (1) Disconnect the G-01 EV charging cable (+) terminal and G-19 main drive lithium-ion battery cable (+) terminal, and measure at main drive lithium-ion battery side.
- (2) Measure the resistance between the G-01 EV charging cable (+) terminal and G-19 main drive lithium-ion battery cable (+) terminal.

OK: No continuity

Q: Is the check result normal?

YES : Go to Step 11.

NO : Go to Step 10.

STEP 10. Check the quick charging contactor (+) in main drive lithium-ion battery

- (1) Removal the quick charging contactor (+) in main drive lithium-ion battery (Refer to P.54D-189).
- (2) Check the quick charging contactor (+) in main drive lithium-ion battery (Refer to P.54D-216).

Q: Is the check result normal?**YES** : Go to Step 11.**NO** : Replace the quick charging contactor (+) in main drive lithium-ion battery (Refer to P.54D-210).**STEP 11. Check whether the DTC is set again.**

Check again if the DTC is set in the EV-ECU.

- (1) Erase the set DTC.
- (2) Connect the quick charging connector to charge the battery completely.
- (3) Check if the DTC is set.

Q: Is DTC P101B set?**YES** : Replace the EV-ECU. Then go to Step 12.**NO** : Intermittent malfunction (Refer to GROUP 00 – How to Use Troubleshooting/Inspection Service Points – How to Cope with Intermittent Malfunction).**STEP 12. Check whether the DTC is set again.**

Check again if the DTC is set in the EV-ECU.

- (1) Erase the set DTC.
- (2) Connect the quick charging connector to charge the battery completely.
- (3) Check if the DTC is set.

Q: Is DTC P101B set?**YES** : Return to Step 1.**NO** : The diagnosis is complete.**DTC P101C Quick CHG. Contactor N Weld**** DANGER**

- *When servicing the high voltage system parts, always shut off the high voltage by removing the service plug (Refer to GROUP 00 – Precautions Before Service, Precautions on how to use the high-voltage vehicle).*
- *When servicing the high voltage system parts, always wear the protective equipment or armor to measure the high voltage (Refer to GROUP 00 – Precautions Before Service, Precautions on how to use the high-voltage vehicle).*

 CAUTION

If there is any problem in the CAN bus lines, an incorrect DTC may be set. Prior to this diagnosis, always diagnose the CAN bus lines (Refer to GROUP 54C – CAN Bus Diagnostics Table).

OPERATION

The EV-ECU controls the quick charging relay (–), which energizes the coil of the quick charging contactor (–) inside the main drive lithium-ion battery, to connect or disconnect the high-voltage circuit.

DTC SET CONDITION

- The system determines whether quick charging contactor (–) is stuck when the quick charging terminates. If yes, DTC P101C will be set.

PROBABLE CAUSES

- Damaged wiring harness or connector(s)
- Malfunction of the quick charging contactor (–)
- Malfunction of the quick charging relay (–)
- Malfunction of the EV-ECU

DIAGNOSIS

STEP 1. Using scan tool MB991958, diagnose the CAN bus lines.

Use the scan tool to diagnose the CAN bus lines.

Q: Is the check result normal?

YES : Go to Step 2.

NO : Repair the CAN bus line (Refer to GROUP 54C – Troubleshooting). Then go to Step 2.

STEP 2. Using scan tool MB991958, check data list

Check the service data associated with the quick charging contactor (–) status.

Data list

- Item No.68: Quick charge contactor (–)

OK: Displays the OFF

Q: Is the diagnostic trouble code set?

YES : Go to Step 3.

NO : Carry out troubleshooting for the DTC P102E, P102F.

STEP 3. STEP 3. Use scan tool MB991958 to confirm a DTC of other systems.

Check if DTC P102E, P102F is set in the EV-ECU.

Q: Is the diagnostic trouble code set?

YES : Carry out troubleshooting for the DTC.

NO : Go to Step 4.

STEP 4. Connector check: C-21, C-22 main drive lithium-ion battery connector**Q: Is the check result normal?**

YES : Go to Step 5.

NO : Repair the damaged connector.

STEP 5. Measure the resistance at C-21, C-22 main drive lithium-ion battery connector

Check the quick charging contactor (–) in the main drive lithium-ion battery (Refer to [P.54D-181](#)).

Q: Is the check result normal?

YES : Go to Step 9.

NO : Go to Step 6.

STEP 6. Connector check: quick charging contactor connector

Removal the main drive lithium-ion battery cover (Refer to [P.54D-194](#)).

Q: Is the check result normal?

YES : Go to Step 7.

NO : Repair the damaged connector.

STEP 7. Check the wiring harness between C-21 main drive lithium-ion battery connector terminal No.12 and quick charging contactor (-) connector terminal No.2, C-22 main drive lithium-ion battery connector terminal No.5 and quick charging contactor (-) connector terminal No.4

NOTE: Before checking harness, check intermediate connector (3) terminal No.4 and No.5 of ground line, and repair if necessary.

Check the signal line for short to ground.

Q: Is the check result normal?

YES : Go to Step 8.

NO : Repair the wiring harness.

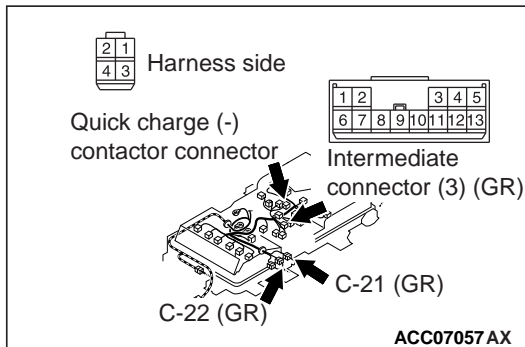
**STEP 8. Check the quick charging contactor (-) in main drive lithium-ion battery**

- (1) Removal the quick charging contactor (-) in main drive lithium-ion battery (Refer to [P.54D-189](#)).
- (2) Check the quick charging contactor (-) in main drive lithium-ion battery (Refer to [P.54D-216](#)).

Q: Is the check result normal?

YES : Go to Step 9.

NO : Replace the quick charging contactor (-) in main drive lithium-ion battery (Refer to [P.54D-210](#)).

STEP 9. Measure the resistance between the G-02 EV charging cable (-) terminal and the G-18 main drive lithium-ion battery cable (-) terminal

⚠ DANGER

- ***When high voltage system components are serviced, be sure to remove service plug to shut down high voltage (Refer to GROUP 00 – Precautions Before Service, Precautions on how to use the high-voltage vehicle).***
 - ***When removing service plug, wear the specified protective equipment.***
- (1) Disconnect the G-02 EV charging cable (-) terminal and G-18 main drive lithium-ion battery cable (-) terminal, and measure at main drive lithium-ion battery side.
 - (2) Measure the resistance between the G-02 EV charging cable (-) terminal and G-18 main drive lithium-ion battery cable (-) terminal.

OK: No continuity

Q: Is the check result normal?

YES : Go to Step 11.

NO : Go to Step 10.

STEP 10. Check the quick charging contactor (-) in main drive lithium-ion battery

- (1) Removal the quick charging contactor (-) in main drive lithium-ion battery (Refer to [P.54D-189](#)).
- (2) Check the quick charging contactor (-) in main drive lithium-ion battery (Refer to [P.54D-216](#)).

Q: Is the check result normal?

YES : Go to Step 11.

NO : Replace the quick charging contactor (-) in main drive lithium-ion battery (Refer to [P.54D-210](#)).

STEP 11. Check whether the DTC is set again.

Check again if the DTC is set in the EV-ECU.

- (1) Erase the set DTC.
- (2) Connect the quick charging connector to charge the battery completely.
- (3) Check if the DTC is set.

Q: Is DTC P101C set?

YES : Replace the EV-ECU. Then go to Step 12.

NO : Intermittent malfunction (Refer to GROUP 00 – How to Use Troubleshooting/Inspection Service Points – How to Cope with Intermittent Malfunction).

STEP 12. Check whether the DTC is set again.

Check again if the DTC is set in the EV-ECU.

- (1) Erase the set DTC.
- (2) Connect the quick charging connector to charge the battery completely.
- (3) Check if the DTC is set.

Q: Is DTC P101C set?

YES : Return to Step 1.

NO : The diagnosis is complete.

Code No. P1A15: High Voltage Circuit (1)**⚠ DANGER**

- *When servicing the high voltage system parts, always shut off the high voltage by removing the service plug (Refer to GROUP 00 – Precautions Before Service, Precautions on how to use the high-voltage vehicle).*
- *When servicing the high voltage system parts, always wear the protective equipment or armor to measure the high voltage (Refer to GROUP 00 – Precautions Before Service, Precautions on how to use the high-voltage vehicle).*

⚠ CAUTION

If there is any problem in the CAN bus lines, an incorrect DTC may be set. Prior to this diagnosis, always diagnose the CAN bus lines (Refer to GROUP 54C – CAN Bus Diagnostics Table).

OPERATION

The high-voltage circuit activation and shutdown are controlled by the EV-ECU. The EV-ECU also monitors the voltage of the smooth condenser in the EMCU via the CAN communication.

DTC SET CONDITIONS

- If the charging time of the smooth condenser in the EMCU reaches the specified time or more when the high-voltage circuit activation, DTC P1A15 will be set.

NOTE: This DTC is set as a current trouble only. Therefore, follow the troubleshooting steps for the current trouble.

PROBABLE CAUSES

- Damaged wiring harness or connector(s)
- Malfunction of the high-voltage fuse No.1 (Main, 280A) (main drive lithium-ion battery assembly)
- Malfunction of the main contactors (+) or (–) in the main drive lithium-ion battery
- Malfunction of the resistor in the main drive lithium-ion battery
- Bus bar in the main drive lithium-ion battery loosely tightened
- Malfunction of the EMCU
- Malfunction of the EV water PTC heater
- Malfunction of the A/C control unit
- Malfunction of the onboard charger/DC-DC converter
- Malfunction of the A/C compressor

DIAGNOSIS**STEP 1. Using scan tool MB991958, diagnose the CAN bus lines**

Use the scan tool to diagnose the CAN bus lines.

Q: Is the check result normal?

YES : Go to Step 3.

NO : Repair the CAN bus line (Refer to GROUP 54C – Troubleshooting). Then go to Step 2.

STEP 2. DTC recheck after resetting CAN bus lines

Check again if DTC P1A15 is set in the EV-ECU.

- (1) Set the electric motor switch from the LOCK (OFF) position to the ON, and then to the START position temporarily.
- (2) Erase the DTC.
- (3) After the electric motor switch from the LOCK (OFF) position, reset the electric motor switch from the LOCK (OFF) position to the ON, and then to the START position temporarily.
- (4) Check if the DTC is set.

Q: Is the DTC set?

YES : Go to Step 3.

NO : This diagnosis is complete.

STEP 3. Use scan tool MB991958 to confirm a diagnostic trouble code of other systems.

Check if the DTC except P0AA1, P1A17 or P1AF2 is set in the EV-ECU.

Q: Is the DTC set?

YES : Carry out troubleshooting for the DTC.

NO : Go to Step 4.

STEP 4. Use scan tool MB991958 to confirm a diagnostic trouble code of other systems.

Check if the DTC is set in the A/C control unit.

Q: Is the DTC set?

YES : Carry out troubleshooting for the DTC (Refer to GROUP 55 – Troubleshooting).

NO : Go to Step 5.

STEP 5. Using scan tool MB991958, check freeze frame (FFD) data

Check the freeze frame data.

Freeze frame data

- Item No.15: MCU: Condenser voltage

OK: Approximately 0 V

Q: Is the check result normal?

YES : Go to Step 6.

NO : Go to Step 9.

STEP 6. Check whether the DTC is set again.

 DANGER

- ***When high voltage system components are serviced, be sure to remove service plug to shut down high voltage (Refer to GROUP 00 – Precautions Before Service, Precautions on how to use the high-voltage vehicle).***
- ***When removing service plug, wear the specified protective equipment.***

Check again if the DTC is set in the EV-ECU.

(1) Remove the service plug.

 DANGER

Isolate bare wires of the disconnected high-voltage circuit with a plastic tape.

- (2) Disconnect the G-21 EV water PTC heater connector.
- (3) Installation the service plug.
- (4) Set the electric motor switch from the LOCK (OFF) position to the ON, and then to the START position temporarily.
- (5) Erase the DTC.
- (6) After the electric motor switch from the LOCK (OFF) position, reset the electric motor switch from the LOCK (OFF) position to the ON, and then to the START position temporarily.
- (7) Check if the DTC is set.

Q: Is the DTC set?

YES : Go to Step 7.

NO : Go to Step 16.

STEP 7. Check whether the DTC is set again.

⚠ DANGER

- ***When high voltage system components are serviced, be sure to remove service plug to shut down high voltage (Refer to GROUP 00 – Precautions Before Service, Precautions on how to use the high-voltage vehicle).***
- ***When removing service plug, wear the specified protective equipment.***

Check again if the DTC is set in the EV-ECU.

(1) Remove the service plug.

⚠ DANGER

Isolate bare wires of the disconnected high-voltage circuit with a plastic tape.

(2) Disconnect the G-20 A/C compressor connector.

(3) Installation the service plug.

(4) Set the electric motor switch from the LOCK (OFF) position to the ON, and then to the START position temporarily.

(5) Erase the DTC.

(6) After the electric motor switch from the LOCK (OFF) position, reset the electric motor switch from the LOCK (OFF) position to the ON, and then to the START position temporarily.

(7) Check if the DTC is set.

Q: Is the DTC set?

YES : Go to Step 8.

NO : Replace the A/C compressor (Refer to GROUP 55 – A/C Compressor).

STEP 8. Check whether the DTC is set again.

 DANGER

- ***When high voltage system components are serviced, be sure to remove service plug to shut down high voltage (Refer to GROUP 00 – Precautions Before Service, Precautions on how to use the high-voltage vehicle).***
- ***When removing service plug, wear the specified protective equipment.***

Check again if the DTC is set in the EV-ECU.

(1) Remove the service plug.

 DANGER

Isolate bare wires of the disconnected high-voltage circuit with a plastic tape.

(2) Disconnect the G-24 inverter and on board charger/DC-DC converter combination (+ terminal) connector, G-25 inverter and on board charger/DC-DC converter combination (– terminal) connector.

(3) Installation the service plug.

(4) Set the electric motor switch from the LOCK (OFF) position to the ON, and then to the START position temporarily.

(5) Erase the DTC.

(6) After the electric motor switch from the LOCK (OFF) position, reset the electric motor switch from the LOCK (OFF) position to the ON, and then to the START position temporarily.

(7) Check if the DTC is set.

Q: Is the DTC set?

YES : Replace the inverter. Then go to Step 21.

NO : Replace the onboard charger/DC-DC converter.

STEP 9. High-voltage fuse No.1 (Main,280A) (main drive lithium-ion battery assembly) check

 DANGER

- ***When high voltage system components are serviced, be sure to remove service plug to shut down high voltage (Refer to GROUP 00 – Precautions Before Service, Precautions on how to use the high-voltage vehicle).***
- ***When removing service plug, wear the specified protective equipment.***

Check the high-voltage fuse No.1 (Main, 280A) (Refer to [P.54D-186](#)).

Q: Is the check result normal?

YES : Go to Step 11.

NO : Replace the high-voltage fuse No.1 (Main, 280A).
Then go to Step 10.

STEP 10. Use scan tool MB991958 to confirm a DTC of other systems.

Check if the DTC is set in the EMCU.

Q: Is the diagnostic trouble code set?

YES : Carry out troubleshooting for the DTC.

NO : Go to Step 21.

STEP 11. Connector check: G-18, G-19 main drive lithium-ion battery connector, G-05, G-06 inverter connector

 **DANGER**

- ***When high voltage system components are serviced, be sure to remove service plug to shut down high voltage (Refer to GROUP 00 – Precautions Before Service, Precautions on how to use the high-voltage vehicle).***
- ***When removing service plug, wear the specified protective equipment.***
- Check whether terminals are engaged correctly (deformation or discoloration).
- Check whether the terminals are tightened to the specified torque.
- Check whether foreign materials are pinched.

Q: Is the check result normal?

YES : Go to Step 12.

NO : Reconnect the terminals or replace the main drive lithium-ion battery cable.

STEP 12. Check the wiring harness between G-05, G-06 inverter connector terminal and G-18, G-19 main drive lithium-ion battery connector terminal.

 **DANGER**

- ***When high voltage system components are serviced, be sure to remove service plug to shut down high voltage (Refer to GROUP 00 – Precautions Before Service, Precautions on how to use the high-voltage vehicle).***
- ***When removing service plug, wear the specified protective equipment.***

Check the high-voltage line for damage.

Q: Is the check result normal?

YES : Go to Step 13.

NO : Replace the main drive lithium-ion battery cable.

STEP 13. Connector check: C-21, C-22 main drive lithium-ion battery connector, C-111 EV-ECU connector

Q: Is the check result normal?

YES : Go to Step 14.

NO : Repair the damaged connector.

STEP 14. Check the wiring harness between C-111 EV-ECU connector terminal No. 105, 106, 107 and C-21 main drive lithium-ion battery connector terminal No.5, 6, C-22 main drive lithium-ion battery connector terminal No.3 or between C-22 main drive lithium-ion battery connector terminal No.5 and the body ground.

Check the signal lines, ground line for open.

Q: Is the check result normal?

YES : Go to Step 15.

NO : Repair the wiring harness.

STEP 15. Check on main contactor (+), (-), charging contactor coil resistance of contactor.

Q: Is the check result normal?

YES : Go to Step 25.

NO : Go to Step 16.

STEP 16. Voltage measurement at G-19 high-voltage connector, service plug

⚠ DANGER

- **Check the high-voltage circuit while reading carefully the precautions on handling a high-voltage vehicle.**
- **Be sure to wear the specified protective equipment when pulling the service plug.**

- (1) Disconnect C-21, C-22 main drive lithium-ion battery connector, and then apply a voltage of 12 V between C-21 main drive lithium-ion battery connector terminals No. 6 and C-22 main drive lithium-ion battery connector terminal No. 5 (at main drive lithium-ion battery side).
- (2) Using a high voltage multimeter, measure the high voltage between the G-19 connection terminal and service plug forward terminal.

OK: 110 V – 180 V

Q: Is the check result normal?

YES : Go to Step 17.

NO : Go to Step 18.

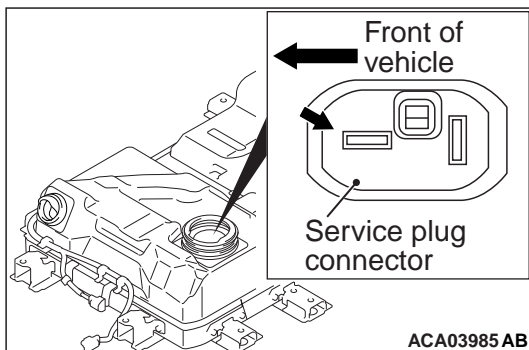

STEP 17. Voltage measurement at G-18 high-voltage, service plug connector**⚠ DANGER**

- **Check the high-voltage circuit while reading carefully the precautions on handling a high-voltage vehicle.**
- **Be sure to wear the specified protective equipment when pulling the service plug.**

- (1) Disconnect C-21, C-22 main drive lithium-ion battery connector, and then apply a voltage of 12 V between C-21 main drive lithium-ion battery connector terminals No. 5 and C-22 main drive lithium-ion battery connector terminal No. 5 (at main drive lithium-ion battery side).
- (2) Using a high voltage multimeter, measure the high voltage between the G-18 connection terminal and service plug connection backward terminal.

OK: 110 V – 180 V

Q: Is the check result normal?

YES : Go to Step 30.

NO : Go to Step 18.

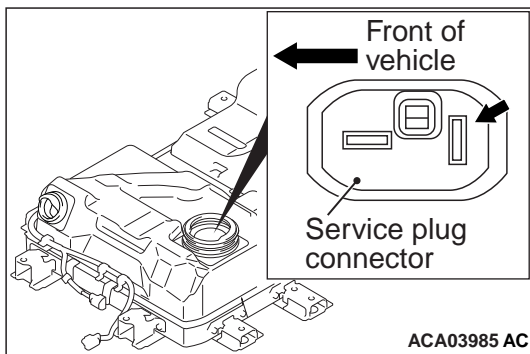
**STEP 18. Check the main contactor (–) or charging contactor in main drive lithium-ion battery**

- (1) Removal the main contactor (–) or charging contactor in main drive lithium-ion battery (Refer to [P.54D-189](#)).
- (2) Check the main contactor (–) or charging contactor in main drive lithium-ion battery (Refer to [P.54D-216](#)).

Q: Is the check result normal?

YES : Go to Step 19.

NO : Replace the main contactor (–) or charging contactor in main drive lithium-ion battery (Refer to [P.54D-210](#)).

STEP 19. Check the resistor in main drive lithium-ion battery

- (1) Removal the resistor in main drive lithium-ion battery (Refer to [P.54D-189](#)).
- (2) Check the resistor in main drive lithium-ion battery (Refer to [P.54D-218](#)).

Q: Is the check result normal?

YES : Go to Step 20.

NO : Replace the resistor in main drive lithium-ion battery (Refer to [P.54D-209](#)).

STEP 20. Check the bus bar in main drive lithium-ion battery

(1) Check whether the bus bar in the main drive lithium-ion battery is tightened correctly (Refer to [P.54D-197](#)).

Q: Is the check result normal?

YES : Go to Step 21.

NO : Retighten the bus bar in the main drive lithium-ion battery (Refer to [P.54D-197](#)).

STEP 21. Use scan tool MB991958, check data list of others system

(1) Select "Reset" for CMUs 01 to 12 on the special function screen, and then execute it.

(2) Check the data list on CMUs 01 to 12.

- Item No. 1: Module voltage

Q: Is the check result normal?

YES : Go to Step 22.

NO : Carry out troubleshooting for the DTC in the BMU.

STEP 22. Connector check: C-22 Main Drive Lithium-ion Battery connector, main contactor (-) connector, charging contactor connector**Q: Is the check result normal?**

YES : Go to Step 23.

NO : Repair the damaged connector.

STEP 23. Check the wiring harness between C-21 main drive lithium-ion battery connector terminal No. 5 and main contactor (-) connector terminal No. 7, C-22 main drive lithium-ion battery connector terminal No. 5 and main contactor (-) connector terminal No. 2

NOTE: Before checking harness, check intermediate connector (3) terminal No. 4 and No. 12 of ground line, and repair if necessary.

Check out signal line and ground line for open circuit.

Q: Is the check result normal?

YES : Go to Step 24.

NO : Repair the wiring harness.

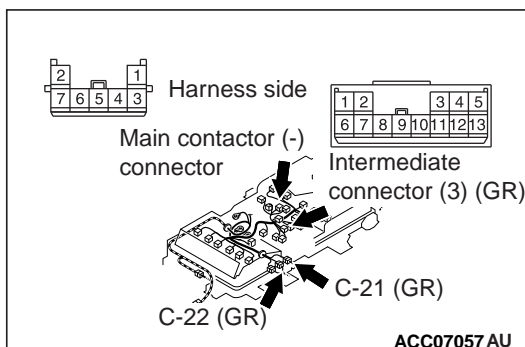

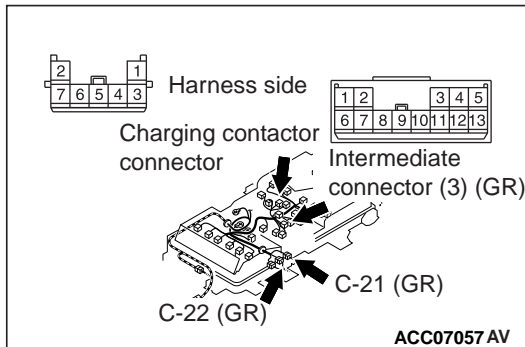

STEP 24. Check the wiring harness between C-21 main drive lithium-ion battery connector terminal No. 6 and charging contactor connector terminal No. 4, C-22 Main Drive Lithium-ion Battery connector terminal No. 5 and charging contactor connector terminal No. 6

NOTE: Before checking harness, check intermediate connector (3) terminal No. 4 and No. 11 of ground line, and repair if necessary.

Check out signal line and ground line for open circuit.

Q: Is the check result normal?

YES : Intermittent malfunction (Refer to GROUP 00 – How to Use Troubleshooting/Inspection Service Points - How to Cope with Intermittent Malfunctions).

NO : Repair the wiring harness.

STEP 25. Measure the resistance of the G-21 EV water PTC heater connector.

⚠ DANGER

- **When high voltage system components are serviced, be sure to remove service plug to shut down high voltage (Refer to GROUP 00 – Precautions Before Service, Precautions on how to use the high-voltage vehicle).**
- **When removing service plug, wear the specified protective equipment.**

- (1) Remove the service plug.
- (2) Disconnect the G-21 EV water PTC heater connector.
- (3) Measure it on the resistance at the EV water PTC heater side.
- (4) Measure the resistance between the G-21 EV water PTC heater connector terminal No.1 and No.2.

OK: 1 MΩ or more

Q: Is the check result normal?

YES : Go to Step 26.

NO : Check the high-voltage fuse No.3 (Refer to [P.54D-186](#)). Replace the EV water PTC heater (Refer to GROUP 55 – EV Water PTC Heater).

STEP 26. Measure the resistance at A-113 EV water PTC heater connector.

- (1) Disconnect the A-113 EV water PTC heater connector and measure it on the resistance at the EV water PTC heater side.
- (2) Measure the resistance between the A-113 EV water PTC heater connector terminal No.3, 4, 5 and the body ground.

OK: No continuity

Q: Is the check result normal?

YES : Go to Step 27.

NO : Replace the EV water PTC heater (Refer to GROUP 55 – EV Water PTC Heater).

STEP 27. Measure the resistance at A-113 EV water PTC heater connector.

- (1) Disconnect the A-113 EV water PTC heater connector and measure it on the resistance at the wiring harness side.
- (2) Measure the resistance between the A-113 EV water PTC heater connector terminal No.3, 4, 5 and the body ground.

OK: No continuity

Q: Is the check result normal?

YES : Go to Step 30.

NO : Go to Step 28.

STEP 28. Connector check: A-113 EV water PTC heater connector, B-01 intermediate connector, C-113 A/C control unit connector.**Q: Is the check result normal?**

YES : Go to Step 29.

NO : Repair the damaged connector.

STEP 29. Check the wiring harness between A-113 EV water PTC heater connector terminal No. 3, 4, 5 and C-113 A/C control unit connector terminal No. 34, 35, 36.

Check the signal line for short circuit.

Q: Is the check result normal?

YES : Replace the A/C controller assembly (Refer to GROUP 55 – Heater Control Unit).

NO : Repair the wiring harness.

STEP 30. Check whether the DTC is set again.

Check again if the DTC is set in the EV-ECU.

- (1) Set the electric motor switch from the LOCK (OFF) position to the ON, and then to the START position temporarily.
- (2) Erase the set DTC.
- (3) After the electric motor switch from the LOCK (OFF) position, reset the electric motor switch from the LOCK (OFF) position to the ON, and then to the START position temporarily.
- (4) Check if the DTC is set.

Q: Is DTC P1A15 set?

YES : Return to Step 1.

NO : The diagnosis is complete.

DTC P1A17 High Voltage Circuit (3)** DANGER**

- *When servicing the high voltage system parts, always shut off the high voltage by removing the service plug (Refer to GROUP 00 – Precautions Before Service, Precautions on how to use the high-voltage vehicle).*
- *When servicing the high voltage system parts, always wear the protective equipment or armor to measure the high voltage (Refer to GROUP 00 – Precautions Before Service, Precautions on how to use the high-voltage vehicle).*

 CAUTION

If there is any problem in the CAN bus lines, an incorrect DTC may be set. Prior to this diagnosis, always diagnose the CAN bus lines (Refer to GROUP 54C – CAN Bus Diagnostics Table).

OPERATION

- The high-voltage circuit activation and shutdown are controlled by the EV-ECU. The EV-ECU also monitors the voltage of the smooth condenser in the EMCU via the CAN communication.

DTC SET CONDITION

- When the main contactors (+) and (–) are set to ON, if the voltage of the smooth condenser in the EMCU is kept at 200 V or less, DTC P1A17 will be set.

PROBABLE CAUSES

- Damaged wiring harness or connector(s)
- Malfunction of the main contactors (+) or (–) in the main drive lithium-ion battery
- Malfunction of the EMCU

DIAGNOSIS**STEP 1. Using scan tool MB991958, diagnose the CAN bus lines.**

Use the scan tool to diagnose the CAN bus lines.

Q: Is the check result normal?

YES : Go to Step 3.

NO : Repair the CAN bus line (Refer to GROUP 54C – Troubleshooting). Then go to Step 2.

STEP 2. DTC recheck after resetting CAN bus lines

Check again if DTC P1A17 is set in the EV-ECU.

- (1) Erase the DTC.
- (2) Set the electric motor switch from the LOCK (OFF) position to the ON, and then to the START position temporarily.
- (3) After the electric motor switch from the LOCK (OFF) position, reset the electric motor switch from the LOCK (OFF) position to the ON position.
- (4) Check if the DTC is set.

Q: Is the DTC set?

YES : Go to Step 3.

NO : This diagnosis is complete.

STEP 3. Use scan tool MB991958 to confirm a DTC of other systems.

Check if DTC P1A15 is set in the EV-ECU.

Q: Is the DTC set?

YES : Carry out troubleshooting for the diagnostic trouble code.

NO : Go to Step 4.

STEP 4. High-voltage fuse No.1 (Main,280A) (main drive lithium-ion battery assembly) check** DANGER**

- *When high voltage system components are serviced, be sure to remove service plug to shut down high voltage (Refer to GROUP 00 – Precautions Before Service, Precautions on how to use the high-voltage vehicle).*
- *When removing service plug, wear the specified protective equipment.*

Check the high-voltage fuse No.1 (Main, 280A) (Refer to [P.54D-186](#)).

Q: Is the check result normal?

YES : Go to Step 6.

NO : Replace the high-voltage fuse No.1 (Main, 280A).
Then go to Step 5.

STEP 5. Use scan tool MB991958 to confirm a DTC of other systems.

Check if the DTC is set in the EMCU.

Q: Is the DTC set?

YES : Carry out troubleshooting for the DTC.

NO : Go to Step 11.

STEP 6. Connector check: G-18, G-19 main drive lithium-ion battery connector, G-05, G-06 inverter connector

 DANGER

- ***When high voltage system components are serviced, be sure to remove service plug to shut down high voltage (Refer to GROUP 00 – Precautions Before Service, Precautions on how to use the high-voltage vehicle).***
- ***When removing service plug, wear the specified protective equipment.***
- Check whether terminals are engaged correctly (deformation or discoloration).
- Check whether the terminals are tightened to the specified torque.
- Check whether foreign materials are pinched.

Q: Is the check result normal?

YES : Go to Step 7.

NO : Reconnect the terminals or replace the main drive lithium-ion battery cable.

STEP 7. Check the wiring harness between G-05, G-06 inverter connector terminal and G-18, G-19 main drive lithium-ion battery connector terminal.

 DANGER

- ***When high voltage system components are serviced, be sure to remove service plug to shut down high voltage (Refer to GROUP 00 – Precautions Before Service, Precautions on how to use the high-voltage vehicle).***
- ***When removing service plug, wear the specified protective equipment.***

Check the high-voltage line for damage.

Q: Is the check result normal?

YES : Go to Step 8.

NO : Replace the main drive lithium-ion battery cable.

STEP 8. Connector check: C-21, C-22 main drive lithium-ion battery connector, C-111 EV-ECU connector

Q: Is the check result normal?

YES : Go to Step 9.

NO : Repair the damaged connector.

STEP 9. Check the wiring harness between C-111 EV-ECU connector terminal No. 105, 106, 107 and C-21 main drive lithium-ion battery connector terminal No.5, 6, C-22 main drive lithium-ion battery connector terminal No.3 or between C-22 main drive lithium-ion battery connector terminal No.5 and body ground.

Check the signal lines, ground line for open.

Q: Is the check result normal?

YES : Go to Step 10.

NO : Repair the wiring harness.

STEP 10. Check on main contactor (+), (-), charging contactor coil resistance of contactor.

Refer to [P.54D-181](#).

Q: Is the check result normal?

YES : Go to Step 15.

NO : Go to Step 11.

STEP 11. Connector check: C-21, C-22 main drive lithium-ion battery connector, main contactor (+), (-) connector

Removal the main drive lithium-ion battery cover (Refer to [P.54D-194](#)).

Q: Is the check result normal?

YES : Go to Step 12.

NO : Repair the damaged connector.

STEP 12. Check the wiring harness between C-22 main drive lithium-ion battery connector terminal No. 3 and main contactor (+) connector terminal No. 3, C-22 main drive lithium-ion battery connector terminal No. 5 and main contactor (+) connector terminal No. 1

NOTE: Before checking harness, check intermediate connector (3) terminal No. 4 and No. 13 of ground line, and repair if necessary.

Check out signal line and ground line for open circuit.

Q: Is the check result normal?

YES : Go to Step 13.

NO : Repair the wiring harness.

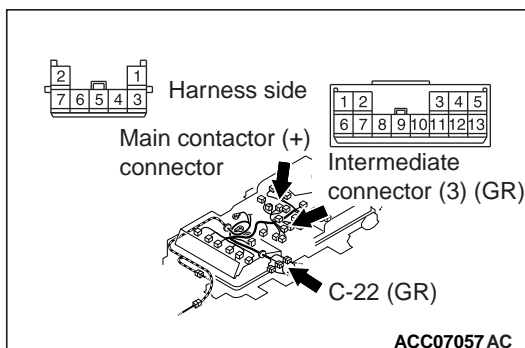

STEP 13. Check the wiring harness between C-21 main drive lithium-ion battery connector terminal No. 5 and main contactor (-) connector terminal No. 7, C-22 main drive lithium-ion battery connector terminal No. 5 and main contactor (-) connector terminal No. 2

NOTE: Before checking harness, check intermediate connector (3) terminal No. 4 and No. 12 of ground line, and repair if necessary.

Check out signal line and ground line for open circuit.

Q: Is the check result normal?

YES : Go to Step 14.

NO : Repair the wiring harness.

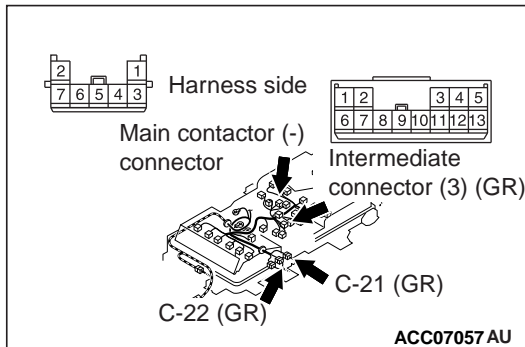

STEP 14. Check the main contactor (+), (-) in main drive lithium-ion battery

- (1) Removal the main contactor (+), (-) in main drive lithium-ion battery (Refer to [P.54D-189](#)).
- (2) Check the main contactor (+), (-) in main drive lithium-ion battery (Refer to [P.54D-216](#)).

Q: Is the check result normal?

YES : Intermittent malfunction (Refer to GROUP 00 – How to Use Troubleshooting/Inspection Service Points – How to Cope with Intermittent Malfunctions).

NO : Replace the main contactor (+), (-) in main drive lithium-ion battery (Refer to [P.54D-210](#)).

STEP 15. Check whether the DTC is set again.

Check again if the DTC is set in the EV-ECU.

- (1) Erase the DTC.
- (2) Set the electric motor switch from the LOCK (OFF) position to the ON, and then to the START position temporarily.
- (3) After the electric motor switch from the LOCK (OFF) position, reset the electric motor switch from the LOCK (OFF) position to the ON position.
- (4) Check if the DTC is set.

Q: Is DTC P1A17 set?

YES : Return to Step 1.

NO : The diagnosis is complete.

DTC P1AFA Quick Charger READY Timeout
 DTC P1AFE Quick charger error
 DTC P1AFF Quick charge port lock error
 DTC P1B00 Quick charger battery conformity error

⚠ CAUTION

If there is any problem in the CAN bus lines, an incorrect DTC may be set. Prior to this diagnosis, always diagnose the CAN bus lines (Refer to GROUP 54C – CAN Bus Diagnostics Table).

OPERATION

- The quick charger communicates with EV-ECU via the local CAN (for the quick charger).

DTC SET CONDITIONS

- When the quick charger present output voltage of 200 V or less continues for 10 seconds or longer, DTC P1AFA will be set.

PROBABLE CAUSES

- Malfunction of the quick charging relay <DTC P1AFA>
- Damaged wiring harness or connector(s) <DTC P1AFA>
- Malfunction of the quick charge contactors (+) or (-) in the Main Drive Lithium-ion Battery <DTC P1AFA>
- Malfunction of the EV charger cable (quick charging) <DTC P1AFA>
- Malfunction of quick charger

DIAGNOSIS

STEP 1. Using scan tool MB991958, diagnose the CAN bus lines.

Use the scan tool to diagnose the CAN bus lines.

Q: Is the check result normal?

YES : Go to Step 3.

NO : Repair the CAN bus line (Refer to GROUP 54C – Troubleshooting). Then go to Step 2.

STEP 2. DTC recheck after resetting CAN bus lines

Check again if DTC P1AFA, P1AFE, P1AFF, or P1B00 is stored in the EV-ECU.

(1) Erase the DTC.

(2) Connect the quick charging connector to charge the battery completely.

(3) Check if the DTC is set.

Q: Is the DTC set?

YES <DTC P1AFA> : Go to Step 3.

YES <DTC P1AFE, P1AFF, P1B00> : Go to Step 17.

NO : This diagnosis is complete.

STEP 3. Use scan tool MB991958 to confirm a diagnostic trouble code of other systems.

Check if DTC P1019, P101A, P102E or P102F is set in the EV-ECU.

Q: Is the DTC set?

YES : Carry out troubleshooting for the DTC.

NO : Go to Step 4.

STEP 4. Measure the voltage at C-21, C-22 main drive lithium-ion battery connector

- (1) Disconnect the on C-21, C-22 main drive lithium-ion battery connector, and measure the voltage at the wiring harness side.
- (2) Connect C-111 EV-ECU connector terminal No.112 and 114 to body ground to turn on the quick charging relay (+) or the quick charging relay (-).
- (3) Set the electric motor switch from the LOCK (OFF) position to the ON position.
- (4) Measure the voltage between the C-21 main drive lithium-ion battery connector terminal No.11, 12 and C-22 main drive lithium-ion battery connector terminal No.5.

OK: System voltage

Q: Is the check result normal?

YES : Go to Step 9.

NO : Go to Step 5.

STEP 5. Connector check: C-21, C-22 main drive lithium-ion battery connector, C-115X quick charging relay (+) connector, C-116X quick charging relay (-) connection, C-112 joint connector

Q: Is the check result normal?

YES : Go to Step 6.

NO : Repair the damaged connector.

STEP 6. Check the wiring harness between C-115X quick charging relay (+) connector terminal No.5 and C-112 joint connector terminal No.9, C-116X quick charging relay (-) connector terminal No.5 and C-112 intermediate connector terminal No.2

Check the power supply line for open circuit.

Q: Is the check result normal?

YES : Go to Step 7.

NO : Repair the wiring harness.

STEP 7. Check the wiring harness between C-115X quick charging relay (+) connector terminal No.4, C-116X quick charging relay (-) connector terminal No.4 and C-21 main drive lithium-ion battery connector terminal No.11, 12 or between C-22 main drive lithium-ion battery connector terminal No.5 and body ground

Check the power supply line and ground line for open circuit.

Q: Is the check result normal?

YES : Go to Step 8.

NO : Repair the wiring harness.

STEP 8. Quick charging relay (+) or (-) check

Check the quick charging relay (+) or (-).

Q: Is the check result normal?

YES : Intermittent malfunction (Refer to GROUP 00 – How to Use Troubleshooting/Inspection Service Points – How to Cope with Intermittent Malfunction).

NO : Replace the quick charging relay (+) or (-).

STEP 9. Measure the resistance at C-21, C-22 main drive lithium-ion battery connector

Check the quick charging contactor (+), (-) in the main drive lithium-ion battery (Refer to [P.54D-181](#)).

Q: Is the check result normal?

YES : Go to Step 10.

NO : Go to Step 14.

STEP 10. Connector check: G-01, G-02 EV charger cable (quick charging) connectors** DANGER**

- **Check the high-voltage circuit while reading carefully the precautions on handling a high-voltage vehicle.**
- **Be sure to wear the specified protective equipment when pulling the service plug.**
- Check whether terminals are engaged correctly (deformation or discoloration).
- Check whether the terminals are tightened to the specified torque.
- Check whether foreign materials are pinched.

Q: Is the check result normal?

YES : Go to Step 11.

NO : Reconnect the terminals or replace the EV charger cable (quick charging).

STEP 11. Voltage measurement at G-01 EV charger cable (quick charging) connector, service plug**⚠ DANGER**

- **Check the high-voltage circuit while reading carefully the precautions on handling a high-voltage vehicle.**
- **Be sure to wear the specified protective equipment when pulling the service plug.**

- (1) Disconnect main drive lithium-ion battery connectors C-21 and C-22, and then apply a voltage of 12 V between main drive lithium-ion battery-side connector C-21 terminal No.11 and C-22 terminal No.5, between main drive lithium-ion battery-side connector C-22 terminal No.3 and C-22 terminal No.5.
- (2) Using a high voltage multimeter, measure the high voltage between the G-01 EV charger cable (quick charging) connection terminal and service plug forward terminal.

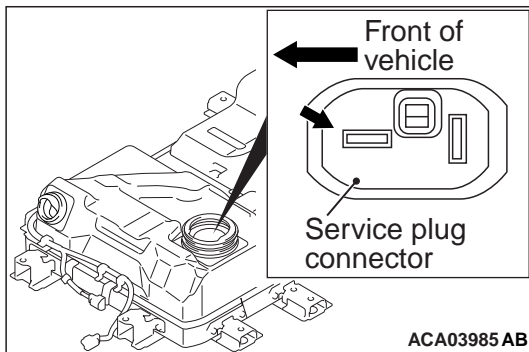
OK: 110 V – 180 V**Q: Is the check result normal?****YES :** Go to Step 12.**NO :** Go to Step 12.**STEP 12. Voltage measurement at G-02 EV charger cable (quick charging) connector, service plug connector****⚠ DANGER**

- **Check the high-voltage circuit while reading carefully the precautions on handling a high-voltage vehicle.**
- **Be sure to wear the specified protective equipment when pulling the service plug.**

- (1) Disconnect main drive lithium-ion battery connectors C-21 and C-22, and then apply a voltage of 12 V between main drive lithium-ion battery-side connector C-21 terminal No.12 and C-22 terminal No.5, between main drive lithium-ion battery-side connector C-21 terminal No.5 and C-22 terminal No.5.
- (2) Using a high voltage multimeter, measure the high voltage between the G-02 EV charger cable (quick charging) connection terminal and service plug connection backward terminal.

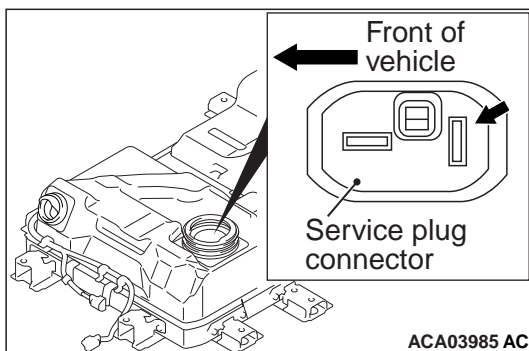
OK: 110 V – 180 V**Q: Is the check result normal?****YES :** Go to Step 17.**NO :** Go to Step 13.

STEP 13. Check the quick charging contactor (+) or (-) in main drive lithium-ion battery

- (1) Removal the quick charging contactor (+) or (-) in main drive lithium-ion battery (Refer to [P.54D-189](#)).
- (2) Check the quick charging contactor (+) or (-) in main drive lithium-ion battery (Refer to [P.54D-216](#)).

Q: Is the check result normal?

YES : Intermittent malfunction (Refer to GROUP 00 – How to Use Troubleshooting/Inspection Service Points – How to Cope with Intermittent Malfunction).

NO : Replace the quick charging contactor (+) or (-) in main drive lithium-ion battery (Refer to [P.54D-210](#)).

STEP 14. Connector check: C-21, C-22 main drive lithium-ion battery connector, quick charging contactor connector

Removal the main drive lithium-ion battery cover (Refer to [P.54D-194](#)).

Q: Is the check result normal?

YES : Go to Step 15.

NO : Repair the damaged connector.

STEP 15. Check the wiring harness between C-21 main drive lithium-ion battery connector terminal No.11 and quick charging contactor (+) connector terminal No.1, C-21 main drive lithium-ion battery connector terminal No.12 and quick charging contactor (-) connector terminal No.2, C-22 main drive lithium-ion battery connector terminal No.5 and quick charging contactor (+) connector terminal No.3, C-22 main drive lithium-ion battery connector terminal No.5 and quick charging contactor (-) connector terminal No.4

NOTE: Before checking harness, check intermediate connector (3) terminal No.3, 4 and No.5 of ground line, and repair if necessary.

Check the signal line for short to ground.

Q: Is the check result normal?

YES : Go to Step 16.

NO : Repair the wiring harness.

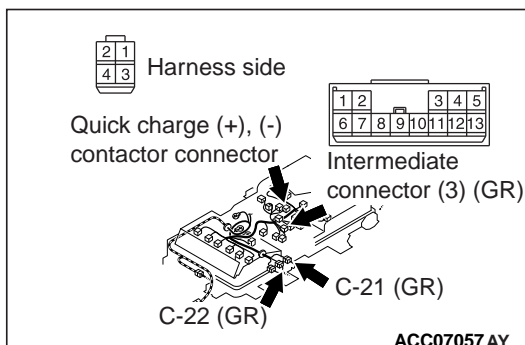

STEP 16. Check the quick charging contactor (+) or (-) in main drive lithium-ion battery

- (1) Removal the quick charging contactor (+) or (-) in main drive lithium-ion battery (Refer to [P.54D-189](#)).
- (2) Check the quick charging contactor (+) or (-) in main drive lithium-ion battery (Refer to [P.54D-216](#)).

Q: Is the check result normal?

YES : Intermittent malfunction (Refer to GROUP 00 – How to Use Troubleshooting/Inspection Service Points – How to Cope with Intermittent Malfunction).

NO : Replace the quick charging contactor (-) in main drive lithium-ion battery (Refer to [P.54D-210](#)).

STEP 17. Check whether the DTC is set again.

Check again if the DTC is set in the EV-ECU.

- (1) Erase the set DTC.
- (2) Connect the quick charging connector to charge the battery completely.
- (3) Check if the DTC is set.

Q: Is DTC P1AFA set?

YES : Check the quick charger. Then go to Step 18.

NO : Intermittent malfunction (Refer to GROUP 00 – How to Use Troubleshooting/Inspection Service Points – How to Cope with Intermittent Malfunction).

STEP 18. Check whether the DTC is set again.

Check again if the DTC is set in the EV-ECU.

- (1) Erase the set DTC.
- (2) Connect the quick charging connector to charge the battery completely.
- (3) Check if the DTC is set.

Q: Is DTC P1AFA set?

YES : Return to Step 1.

NO : The diagnosis is complete.

DTC P1AFB Quick Charging Time Over

 **CAUTION**

If there is any problem in the CAN bus lines, an incorrect DTC may be set. Prior to this diagnosis, always diagnose the CAN bus lines (Refer to GROUP 54C – CAN Bus Diagnostics Table).

OPERATION

- BMU communicates with EV-ECU via CAN.

DTC SET CONDITIONS

- If the quick charging continues for the maximum quick charging time of 5 minutes or longer, DTC P1AFB will be set.
- The system is not being charged from external power supply equipment.

PROBABLE CAUSES

- Malfunction of the BMU
- Malfunction of the EV-ECU
- Malfunction of the main drive lithium-ion battery

DIAGNOSIS

STEP 1. Using scan tool MB991958, diagnose the CAN bus lines.

Use the scan tool to diagnose the CAN bus lines.

Q: Is the check result normal?

YES : Go to Step 3.

NO : Repair the CAN bus line (Refer to GROUP 54C – CAN Bus Diagnostics Table). Then go to Step 2.

STEP 2. DTC recheck after resetting CAN bus lines

Check again if DTC P1AFB is set in the EV-ECU.

(1) Erase the DTC.

(2) Connect the quick charging connector to charge the battery completely.

(3) Check if the DTC is set.

Q: Is the DTC set?

YES : Go to Step 3.

NO : This diagnosis is complete.

STEP 3. Using scan tool MB991958, check data list

Check the BMU data list.

- Item No. 3: Battery cell maximum voltage
- Item No. 5: Battery cell minimum voltage
- Item No. 8: Module maximum temperature
- Item No. 10: Module minimum temperature

Q: Is the check result normal?

YES : Go to Step 4.

NO : Replace the BMU (Refer to [P.54D-188](#)). Then go to Step 8 .

STEP 4. Use scan tool MB991958 to confirm a DTC of other systems.

Charge the battery fully by regular charging. Then, check if DTC is set in the EV-ECU.

Q: Is the DTC set?

YES : Troubleshoot the EV-ECU.

NO : Go to Step 5.

STEP 5. Using scan tool MB991958, check data list

- (1) Check the domestic power supply facility.
- (2) Connect the regular charging cable.
- (3) Check the BMU service data.
 - Item No. 3: Battery cell maximum voltage
 - Item No. 4: Maximum voltage cell ID
 - Item No. 5: Battery cell minimum voltage
 - Item No. 6: Minimum voltage cell ID
 - Item No. 33: BAT. cell voltage difference MAX

OK: The highest cell voltage exceeds 4.0 V, and the voltages among the cells differs by less than 0.2 V.

Q: Is the check result normal?

YES : Go to Step 7.

NO : Go to Step 6.

STEP 6. Use scan tool MB991958 to confirm a data list of other systems.

- (1) Select "Reset" for ID of the cell of the lowest voltage (CMU ID) on the special function screen in CMU (Refer to GROUP 00 – Precautions Before Service, How to Reset Failure Information in the CMU EEPROM), and then execute it.
- (2) Check the data list corresponding to the relevant CMU ID.

Q: Is the check result normal?

YES : Go to Step 7.

NO : Replace the main drive lithium-ion battery. Then go to Step 8.

STEP 7. Check whether the DTC is set again.

Check again if the DTC is set in the EV-ECU.

- (1) Erase the DTC.
- (2) Connect the quick charging connector to charge the battery completely.
- (3) Check if the DTC is set.

Q: Is DTC P1AFB set?

YES : Replace the EV-ECU. Then go to Step 8.

NO : The diagnosis is complete.

STEP 8. Check whether the DTC is set again.

Check again if the DTC is set in the EV-ECU.

- (1) Erase the DTC.
- (2) Connect the quick charging connector to charge the battery completely.
- (3) Check if the DTC is set.

Q: Is DTC P1AFB set?

YES : Return to Step 1.

NO : The diagnosis is complete.

DTC P1AFC: Quick Charging Current**⚠ CAUTION**

If there is any problem in the CAN bus lines, an incorrect DTC may be set. Prior to this diagnosis, always diagnose the CAN bus lines (Refer to GROUP 54C – CAN Bus Diagnostics Table).

OPERATION

- The quick charger communicates with EV-ECU via the local CAN (for the quick charger).
- BMU communicates with EV-ECU via CAN.

DTC SET CONDITION

- If the main drive lithium-ion battery current received from the BMU and the quick charge output current received from the quick charger is higher than the specified value for 5 seconds or longer, DTC P1AFC will be set.

PROBABLE CAUSES

- Malfunction of wiring harness and connectors (Local CAN (for quick charger))
- Malfunction of the EV charger cable (quick charging)
- Malfunction of quick charger
- Malfunction of the BMU
- Malfunction of the current sensor in the main drive lithium-ion battery

DIAGNOSIS**⚠ DANGER**

- *When high voltage system components are serviced, be sure to remove service plug to shut down high voltage (Refer to GROUP 00 – Precautions Before Service, Precautions on how to use the high-voltage vehicle).*
- *When removing service plug, wear the specified protective equipment.*

STEP 1. Using scan tool MB991958, diagnose the CAN bus lines.

Use the scan tool to diagnose the CAN bus lines.

Q: Is the check result normal?

YES : Go to Step 3.

NO : Repair the CAN bus line (Refer to GROUP 54C – Troubleshooting). Then go to Step 2.

STEP 2. DTC recheck after resetting CAN bus lines

Check again if DTC P1AFC is set in the EV-ECU.

(1) Erase the DTC.

(2) Connect the quick charging connector to charge the battery completely.

(3) Check if the DTC is set.

Q: Is the DTC set?

YES : Go to Step 3.

NO : This diagnosis is complete.

STEP 3. Current sensor check

Carry out the simple inspection of the current sensor.

Q: Is the check result normal?

YES : Go to Step 4.

NO : Go to Step 8.

STEP 4. Measure the local CAN (for quick charger) terminator resistor

(1) Disconnect the C-111 EV-ECU connector, and measure the resistance at the EV-ECU side.

(2) Measure the resistance between terminal No. 101 and No. 102.

OK: $120 \pm 20 \Omega$

Q: Is the check result normal?

YES : Go to Step 5.

NO : Replace the EV-ECU. Then go to Step 10.

STEP 5. Measure the local CAN (for quick charger) terminator resistor

(1) Disconnect the C-111 EV-ECU connector, and measure the resistance at the wiring harness side.

(2) Connect the quick charger.

(3) Measure the resistance between terminal No. 101 and No. 102.

OK: $120 \pm 20 \Omega$

Q: Is the check result normal?

YES : Go to Step 9.

NO : Go to Step 6.

STEP 6. Check the local CAN (for quick charger) bus connector: G-10 quick charging connector, C-111 EV-ECU connector

Q: Is the check result normal?

YES : Go to Step 7.

NO : Repair the damaged connector.

STEP 7. Check the local CAN (for quick charger) bus line between the G-10 quick charging connection terminal No. 8, 9 and C-111 EV-ECU connector terminal No. 101, 102.

Check the signal lines for short to ground or open circuit.

Q: Is the check result normal?

YES : Check the quick charger. Then go to Step 10.

NO : Repair the wiring harness.

STEP 8. Use scan tool MB991958 to confirm a diagnostic trouble code of other systems.

Check if one or some of the DTCs are set in the BMU.

Q: Is the DTC set?

YES : Carry out troubleshooting for the diagnostic trouble code.

NO : Intermittent malfunction (Refer to GROUP 00 – How to Use Troubleshooting/Inspection Service Points – How to Cope with Intermittent Malfunction).

STEP 9. Check whether the DTC is set again.

Check again if the DTC is set in the EV-ECU.

(1) Erase the DTC.

(2) Connect the quick charging connector to charge the battery completely.

(3) Check if the DTC is set.

Q: Is DTC P1AFC set?

YES : Replace the BMU (Refer to [P.54D-188](#)). Then go to Step 10.

NO : The diagnosis is complete.

STEP 10. Check whether the DTC is set again.

Check again if the DTC is set in the EV-ECU.

(1) Erase the DTC.

(2) Connect the quick charging connector to charge the battery completely.

(3) Check if the DTC is set.

Q: Is DTC P1AFC set?

YES : Return to Step 1.

NO : The diagnosis is complete.

DTC P1AFD Quick Charging Voltage**⚠ CAUTION**

If there is any problem in the CAN bus lines, an incorrect DTC may be set. Prior to this diagnosis, always diagnose the CAN bus lines (Refer to GROUP 54C – CAN Bus Diagnostics Table).

OPERATION

- BMU communicates with EV-ECU via CAN.
- The quick charging plug communicates with EV-ECU via the local CAN (for the quick charger).

DTC CONDITION

- If the difference between the present output voltage and total battery voltage of 10 V or more continues for 5 seconds or longer, DTC P1AFD will be set.

PROBABLE CAUSES

- Malfunction of the quick charging relay
- Damaged wiring harness or connector(s)
- Malfunction of the quick charging contactors (+) or (–) in the main drive lithium-ion battery
- Malfunction of the EV charger cable (quick charging)
- Malfunction of quick charger

DIAGNOSIS

STEP 1. Using scan tool MB991958, diagnose the CAN bus lines.

Use the scan tool to diagnose the CAN bus lines.

Q: Is the check result normal?

YES : Go to Step 3.

NO : Repair the CAN bus line (Refer to GROUP 54C – Troubleshooting). Then go to Step 2.

STEP 2. DTC recheck after resetting CAN bus lines

Check again if DTC P1AFD is set in the EV-ECU.

- (1) Erase the DTC.
- (2) Connect the quick charging connector to charge the battery completely.
- (3) Check if the DTC is set.

Q: Is the DTC set?

YES : Go to Step 3.

NO : This diagnosis is complete.

STEP 3. Use scan tool MB991958 to confirm a diagnostic trouble code of other systems.

Check if DTC P1019, P101A, P102E or P102F is set in the EV-ECU.

Q: Is the DTC set?

YES : Carry out troubleshooting for the DTC.

NO : Go to Step 4.

STEP 4. Measure the voltage at C-21, C-22 main drive lithium-ion battery connector

- (1) Disconnect the on C-21, C-22 main drive lithium-ion battery connector, and measure the voltage at the wiring harness side.
- (2) Connect C-111 EV-ECU connector terminal No.112 and 114 to body ground to turn on the quick charging relay (+) or the quick charging relay (-).
- (3) Set the electric motor switch from the LOCK (OFF) position to the ON position.
- (4) Measure the voltage between the C-21 main drive lithium-ion battery connector terminal No.11, 12 and C-22 main drive lithium-ion battery connector terminal No.5.

OK: System voltage

Q: Is the check result normal?

YES : Go to Step 9.

NO : Go to Step 5.

STEP 5. Connector check: C-21, C-22 main drive lithium-ion battery connector, C-115X quick charging relay (+) connector, C-116X quick charging relay (-) connection, C-112 joint connector

Q: Is the check result normal?

YES : Go to Step 6.

NO : Repair the damaged connector.

STEP 6. Check the wiring harness between C-115X quick charging relay (+) connector terminal No.5 and C-112 intermediate connector terminal No.9, C-116X quick charging relay (-) connector terminal No.5 and C-112 joint connector terminal No.2

Check the power supply line for open circuit.

Q: Is the check result normal?

YES : Go to Step 7.

NO : Repair the wiring harness.

STEP 7. Check the wiring harness between C-115X quick charging relay (+) connector terminal No.4, C-116X quick charging relay (-) connector terminal No.4 and C-21 main drive lithium-ion battery connector terminal No.11, 12 or between C-22 main drive lithium-ion battery connector terminal No.5 and body ground

Check the power supply line and ground line for open circuit.

Q: Is the check result normal?

YES : Go to Step 8.

NO : Repair the wiring harness.

STEP 8. Quick charging relay (+) or (-) check

Check the quick charging relay (+) or (-).

Q: Is the check result normal?

YES : Intermittent malfunction (Refer to GROUP 00 – How to Use Troubleshooting/Inspection Service Points – How to Cope with Intermittent Malfunction).

NO : Replace the quick charging relay (+) or (-).

STEP 9. Measure the resistance at C-21, C-22 main drive lithium-ion battery connector

Check the quick charging contactor (+), (-) in the main drive lithium-ion battery (Refer to [P.54D-181](#)).

Q: Is the check result normal?

YES : Go to Step 10.

NO : Go to Step 11.

STEP 10. Connector check: G-01, G-02 EV charger cable (quick charging) connectors

⚠ DANGER

- **Check the high-voltage circuit while reading carefully the precautions on handling a high-voltage vehicle.**
- **Be sure to wear the specified protective equipment when pulling the service plug.**
- Check whether terminals are engaged correctly (deformation or discoloration).
- Check whether the terminals are tightened to the specified torque.
- Check whether foreign materials are pinched.

Q: Is the check result normal?

YES : Go to Step 14.

NO : Reconnect the terminals or replace the EV charger cable (quick charging).

STEP 11. Connector check: C-21, C-22 main drive lithium-ion battery connector, quick charging contactor connector
Removal of the main drive lithium-ion battery cover (Refer to P.54D-194).

Q: Is the check result normal?

YES : Go to Step 12.

NO : Repair the damaged connector.

STEP 12. Check the wiring harness between C-21 main drive lithium-ion battery connector terminal No.11 and quick charging contactor (+) connector terminal No.1, C-21 main drive lithium-ion battery connector terminal No.12 and quick charging contactor (-) connector terminal No.2, C-22 main drive lithium-ion battery connector terminal No.5 and quick charging contactor (+) connector terminal No.3, C-22 main drive lithium-ion battery connector terminal No.5 and quick charging contactor (-) connector terminal No.4

NOTE: Before checking harness, check intermediate connector (3) terminal No.3, 4 and No.5 of ground line, and repair if necessary.

Check the signal line for short to ground.

Q: Is the check result normal?

YES : Go to Step 13.

NO : Repair the wiring harness.

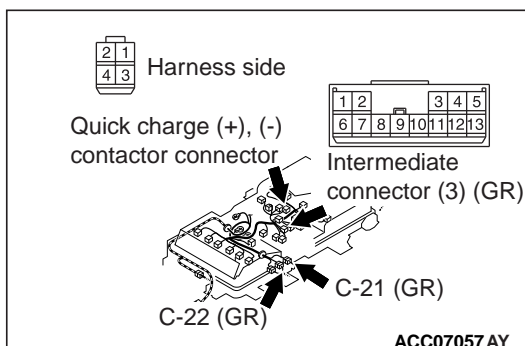

STEP 13. Check the quick charging contactor (+) or (-) in main drive lithium-ion battery

- (1) Removal the quick charging contactor (+) or (-) in main drive lithium-ion battery (Refer to [P.54D-189](#)).
- (2) Check the quick charging contactor (+) or (-) in main drive lithium-ion battery (Refer to [P.54D-216](#)).

Q: Is the check result normal?

YES : Intermittent malfunction (Refer to GROUP 00 – How to Use Troubleshooting/Inspection Service Points – How to Cope with Intermittent Malfunction).

NO : Replace the quick charging contactor (-) in main drive lithium-ion battery (Refer to [P.54D-210](#)).

STEP 14. Check whether the DTC is set again.

Check again if the DTC is set in the EV-ECU.

- (1) Erase the DTC.
- (2) Connect the quick charging connector to charge the battery completely.
- (3) Check if the DTC is set.

Q: Is DTC P1AFC set?

YES : Check the quick charger. Then go to Step 15.

NO : Intermittent malfunction (Refer to GROUP 00 – How to Use Troubleshooting/Inspection Service Points – How to Cope with Intermittent Malfunctions).

STEP 15. Check whether the DTC is set again.

Check again if the DTC is set in the EV-ECU.

- (1) Erase the DTC.
- (2) Connect the quick charging connector to charge the battery completely.
- (3) Check if the DTC is set.

Q: Is DTC P1AFC set?

YES : Return to Step 1.

NO : The diagnosis is complete.

DTC P1B01 Quick Charged Vehicle Error**OPERATION**

- BMU communicates with EV-ECU via CAN.
- The quick charging plug communicates with EV-ECU via the local CAN (for the quick charger).

DTC SET CONDITION

- If the vehicle error judgment signal is received from the quick charger, DTC P1B01 will be set.

PROBABLE CAUSES

- Malfunction of the quick charging relays (+), (-)
- Damaged wiring harness or connector(s)
- Malfunction of the quick charging contactors (+) or (-) in the main drive lithium-ion battery
- Malfunction of the EV charger cable (quick charging)
- Malfunction of quick charger

DIAGNOSIS

STEP 1. Use scan tool MB991958 to confirm a diagnostic trouble code of other systems.

Check if DTC P1019, P101A, P102E or P102F is set in the EV-ECU.

Q: Is the DTC set?

YES : Carry out troubleshooting for the DTC.

NO : Go to Step 2.

STEP 2. Measure the resistance between the G-01 EV charging cable (+) terminal and the G-19 main drive lithium-ion battery cable (+) terminal

 **DANGER**

- ***When high voltage system components are serviced, be sure to remove service plug to shut down high voltage (Refer to GROUP 00 – Precautions Before Service, Precautions on how to use the high-voltage vehicle).***
 - ***When removing service plug, wear the specified protective equipment.***
- (1) Disconnect the G-01 EV charging cable (+) terminal and G-19 main drive lithium-ion battery cable (+) terminal, and measure at main drive lithium-ion battery side.
 - (2) Measure the resistance between the G-01 EV charging cable (+) terminal and G-19 main drive lithium-ion battery cable (+) terminal.

OK: No continuity

Q: Is the check result normal?

YES : Go to Step 3.

NO : Go to Step 3.

STEP 3. Measure the resistance between the G-02 EV charging cable (-) terminal and the G-18 main drive lithium-ion battery cable (-) terminal

⚠ DANGER

- ***When high voltage system components are serviced, be sure to remove service plug to shut down high voltage (Refer to GROUP 00 – Precautions Before Service, Precautions on how to use the high-voltage vehicle).***
 - ***When removing service plug, wear the specified protective equipment.***
- (1) Disconnect the G-02 EV charging cable (-) terminal and G-18 main drive lithium-ion battery cable (-) terminal, and measure at main drive lithium-ion battery side.
 - (2) Measure the resistance between the G-02 EV charging cable (-) terminal and G-18 main drive lithium-ion battery cable (-) terminal.

OK: No continuity

Q: Is the check result normal?

YES : Go to Step 4.

NO : Go to Step 9.

STEP 4. Measure the voltage at C-21, C-22 main drive lithium-ion battery connector

- (1) Disconnect the on C-21, C-22 main drive lithium-ion battery connector, and measure the voltage at the wiring harness side.
- (2) Connect C-111 EV-ECU connector terminal No.112 and 114 to body ground to turn on the quick charging relay (+) or the quick charging relay (-).
- (3) Set the electric motor switch from the LOCK (OFF) position to the ON position.
- (4) Measure the voltage between the C-21 main drive lithium-ion battery connector terminal No.11, 12 and C-22 main drive lithium-ion battery connector terminal No.5.

OK: System voltage

Q: Is the check result normal?

YES : Go to Step 9.

NO : Go to Step 5.

STEP 5. Connector check: C-21, C-22 main drive lithium-ion battery connector, C-115X quick charging relay (+) connector, C-116X quick charging relay (-) connection, C-112 joint connector

Q: Is the check result normal?

YES : Go to Step 6.

NO : Repair the damaged connector.

STEP 6. Check the wiring harness between C-115X quick charging relay (+) connector terminal No.5 and C-112 joint connector terminal No.9, C-116X quick charging relay (-) connector terminal No.5 and C-112 joint connector terminal No.2

Check the power supply line for open circuit.

Q: Is the check result normal?

YES : Go to Step 7.

NO : Repair the wiring harness.

STEP 7. Check the wiring harness between C-115X quick charging relay (+) connector terminal No.4, C-116X quick charging relay (-) connector terminal No.4 and C-21 main drive lithium-ion battery connector terminal No.11, 12 or between C-22 main drive lithium-ion battery connector terminal No.5 and body ground

Check the power supply line and ground line for open circuit.

Q: Is the check result normal?

YES : Go to Step 8.

NO : Repair the wiring harness.

STEP 8. Quick charging relay (+) or (-) check

Check the quick charging relay (+) or (-).

Q: Is the check result normal?

YES : Intermittent malfunction (Refer to GROUP 00 – How to Use Troubleshooting/Inspection Service Points – How to Cope with Intermittent Malfunction.

NO : Replace the quick charging relay (+) or (-).

STEP 9. Measure the resistance at C-21, C-26 main drive lithium-ion battery connector

Check the quick charging contactor (+), (-) in the main drive lithium-ion battery (Refer to [P.54D-181](#)).

Q: Is the check result normal?

YES : Go to Step 10.

NO : Go to Step 11.

STEP 10. Connector check: G-01, G-02 EV charger cable (quick charging) connectors

⚠ DANGER

- **Check the high-voltage circuit while reading carefully the precautions on handling a high-voltage vehicle.**
- **Be sure to wear the specified protective equipment when pulling the service plug.**
- Check whether terminals are engaged correctly (deformation or discoloration).
- Check whether the terminals are tightened to the specified torque.
- Check whether foreign materials are pinched.

Q: Is the check result normal?

YES : Go to Step 14.

NO : Reconnect the terminals or replace the EV charger cable (quick charging).

STEP 11. Connector check: C-21, C-22 main drive lithium-ion battery connector, quick charging contactor connector
Removal of the main drive lithium-ion battery cover (Refer to [P.54D-194](#)).

Q: Is the check result normal?

YES : Go to Step 12.

NO : Repair the damaged connector.

STEP 12. Check the wiring harness between C-21 main drive lithium-ion battery connector terminal No.11 and quick charging contactor (+) connector terminal No.1, C-21 main drive lithium-ion battery connector terminal No.12 and quick charging contactor (-) connector terminal No.2, C-22 main drive lithium-ion battery connector terminal No.5 and quick charging contactor (+) connector terminal No.3, C-22 main drive lithium-ion battery connector terminal No.5 and quick charging contactor (-) connector terminal No.4

NOTE: Before checking harness, check intermediate connector (3) terminal No.3, 4 and No.5 of ground line, and repair if necessary.

Check the signal line for short to ground.

Q: Is the check result normal?

YES : Go to Step 13.

NO : Repair the wiring harness.

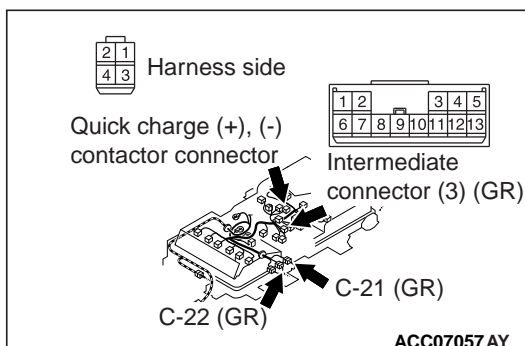

STEP 13. Check the quick charging contactor (+) or (-) in main drive lithium-ion battery

- (1) Removal the quick charging contactor (+) or (-) in main drive lithium-ion battery (Refer to P.54D-189).
- (2) Check the quick charging contactor (+) or (-) in main drive lithium-ion battery (Refer to P.54D-216).

Q: Is the check result normal?

YES : Intermittent malfunction (Refer to GROUP 00 – How to Use Troubleshooting/Inspection Service Points – How to Cope with Intermittent Malfunction).

NO : Replace the quick charging contactor (-) in main drive lithium-ion battery (Refer to P.54D-210).

STEP 14. Check whether the DTC is set again.

Check again if the DTC is set in the EV-ECU.

- (1) Erase the DTC.
- (2) Connect the quick charging connector to charge the battery completely.
- (3) Check if the DTC is set.

Q: Is DTC P1B01 set?

YES : Check the quick charger. Then go to Step 15.

NO : Intermittent malfunction (Refer to GROUP 00 – How to Use Troubleshooting/Inspection Service Points – How to Cope with Intermittent Malfunctions).

STEP 15. Check whether the DTC is set again.

Check again if the DTC is set in the EV-ECU.

- (1) Erase the DTC.
- (2) Connect the quick charging connector to charge the battery completely.
- (3) Check if the DTC is set.

Q: Is DTC P1B01 set?

YES : Return to Step 1.

NO : The diagnosis is complete.

DTC P1B04 Charging Cell MAX Voltage High
DTC P1B05 Charging Cell MIN. Voltage Low
DTC P1B07 Charging Total Battery Voltage

⚠ CAUTION

If there is any problem in the CAN bus lines, an incorrect DTC may be set. Prior to this diagnosis, always diagnose the CAN bus lines (Refer to GROUP 54C – CAN Bus Diagnostics Table).

OPERATION

- BMU communicates with EV-ECU via CAN.

DTC SET CONDITIONS

- During charging

- If the highest cell voltage remains more than a predetermined value, DTC P1B04 will be set.
- If the lowest cell voltage remains less than a predetermined value, DTC P1B05 will be set.
- If the total battery voltage remains at a certain value, DTC P1B07 will be set.

PROBABLE CAUSES

- Malfunction of the BMU
- Malfunction of the module in the main drive lithium-ion battery

DIAGNOSIS

STEP 1. Using scan tool MB991958, diagnose the CAN bus lines.

Use the scan tool to diagnose the CAN bus lines.

Q: Is the check result normal?

YES : Go to Step 3.

NO : Repair the CAN bus line (Refer to GROUP 54C – CAN Bus Diagnostics Table). Then go to Step 2.

STEP 2. DTC recheck after resetting CAN bus lines

Check again if DTC P1B04, P1B05, or P1B07 is set in the EV-ECU.

(1) Erase the DTC.

(2) Connect the regular charging connector or the quick charging connector to charge the battery completely.

(3) Check if the DTC is set.

Q: Is the DTC set?

YES : Go to Step 3.

NO : This diagnosis is complete.

STEP 3. Using scan tool MB991958, check data list

Check the BMU service data.

- Item No. 3: Battery cell maximum voltage
- Item No. 4: Maximum voltage cell ID
- Item No. 5: Battery cell minimum voltage
- Item No. 6: Minimum voltage cell ID
- Item No. 7: Battery total voltage

Q: Is the check result normal?

YES : Go to Step 4.

NO : RReplace the BMU (Refer to [P.54D-188](#)). Then go to Step 5.

STEP 4. Use scan tool MB991958 to confirm a data list of other systems.

(1) Select "Reset" for ID of the cell of the lowest or highest voltage (CMU ID) on the special function screen in CMU (Refer to GROUP 00 – Precautions Before Service, How to Reset Failure Information in the CMU EEPROM), and then execute it.

(2) Check the data list regarding the ID (CMU ID) of the cell of lowest or highest voltage.

Q: Is the check result normal?

YES : Go to Step 5.

NO : Replace the main drive lithium-ion battery assembly. Then go to Step 5.

STEP 5. Check whether the DTC is set again.

Check again if the DTC is set in the EV-ECU.

- (1) Erase the DTC.
- (2) Connect the regular charging connector or the quick charging connector to charge the battery completely.
- (3) Check if the DTC is set.

Q: Is DTC P1B04, P1B05 or P1B07 set?

YES : Return to Step 1.

NO : The diagnosis is complete.

DTC P1B06 Charging Cell MAX Temp. High

 CAUTION

If there is any problem in the CAN bus lines, an incorrect DTC may be set. Prior to this diagnosis, always diagnose the CAN bus lines (Refer to GROUP 54C – CAN Bus Diagnostics Table).

OPERATION

- BMU communicates with EV-ECU via CAN.

DTC SET CONDITION

- If the highest cell temperature remains more than a predetermined value, DTC P1B06 will be set.

PROBABLE CAUSES

- Malfunction of the BMU
- Malfunction of the module in the main drive lithium-ion battery
- Malfunction of air outlet changeover system

DIAGNOSIS

STEP 1. Using scan tool MB991958, diagnose the CAN bus lines.

Use the scan tool to diagnose the CAN bus lines.

Q: Is the check result normal?

YES : Go to Step 3.

NO : Repair the CAN bus line (Refer to GROUP 54C – CAN Bus Diagnostics Table). Then go to Step 2.

STEP 2. DTC recheck after resetting CAN bus lines

Check again if DTC P1B06 is set in the EV-ECU.

- (1) Erase the DTC.
- (2) Connect the regular charging connector or the quick charging connector to charge the battery completely.
- (3) Check if the DTC is set.

Q: Is the DTC set?

YES : Go to Step 3.

NO : This diagnosis is complete.

STEP 3. Main drive lithium-ion battery cooling system check

Check that when operating the A/C (cooling), the cool air flows out to the foot area using the air outlet changeover dial (FOOT mode).

Q: Is the check result normal?

YES : Go to Step 4.

NO : Check the heater/air conditioning/ventilation (Refer to GROUP 55 – Air Outlet Changeover Damper Motor Check). Then go to Step 4.

STEP 4. Using scan tool MB991958, check data list

Check the BMU service data.

- Item No. 8: Module maximum temperature
- Item No. 9: Maximum temperature module ID

Q: Is the check result normal?

YES : Go to Step 5.

NO : Replace the BMU (Refer to [P.54D-188](#)). Then go to Step 6 .

STEP 5. Use scan tool MB991958 to confirm a data list of other systems.

- (1) Select "Reset" for ID of the module having the highest temperature (CMU ID) on the special function screen in CMU (Refer to GROUP 00 – Precautions Before Service, How to Reset Failure Information in the CMU EEPROM), and then execute it.
- (2) Check the data list regarding the ID (CMU ID) of the module having the highest temperature.

Q: Is the check result normal?

YES : Go to Step 6.

NO : Replace the main drive lithium-ion battery assembly. Then go to Step 6.

STEP 6. Check whether the DTC is set again.

Check again if the DTC is set in the EV-ECU.

- (1) Erase the DTC.
- (2) Connect the regular charging connector or the quick charging connector to charge the battery completely.
- (3) Check if the DTC is set.

Q: Is DTC P1B06 set?

YES : Return to Step 1.

NO : The diagnosis is complete.

DTC P1B0C On Board Charging Over Current
DTC P1B21 OBC Output Current



If there is any problem in the CAN bus lines, an

incorrect DTC may be set. Prior to this diagnosis, always diagnose the CAN bus lines (Refer to GROUP 54C – CAN Bus Diagnostics Table).

OPERATION

- The on board charger and BMU communicate with EV-ECU via CAN.

DTC SET CONDITIONS

- If the battery current value received from the BMU is larger than the on board charger current command value by the specified value or more for 5 seconds or longer, DTC P1B0C will be set.

- If the battery current received from the BMU is larger than the charger output current value received from the on board charger via the CAN by the specified value or more for 5 seconds or longer, DTC P1B21 will be set.

PROBABLE CAUSES

- Malfunction of the on board charger
- Malfunction of the BMU
- Malfunction of the main drive lithium-ion battery assembly
- Malfunction of the EV-ECU

DIAGNOSIS

STEP 1. Using scan tool MB991958, diagnose the CAN bus lines.

Use the scan tool to diagnose the CAN bus lines.

Q: Is the check result normal?

YES : Go to Step 3.

NO : Repair the CAN bus line (Refer to GROUP 54C – CAN Bus Diagnostics Table). Then go to Step 2.

STEP 2. DTC recheck after resetting CAN bus lines

Check again if DTC P1B0C or P1B21 is set in the EV-ECU.

(1) Erase the DTC.

(2) Connect the regular charging connector to charge the battery completely.

(3) Check if the DTC is set.

Q: Is the DTC set?

YES : Go to Step 3.

NO : This diagnosis is complete.

STEP 3. Use scan tool MB991958 to confirm a diagnostic trouble code of other systems.

Check if the DTC is set in the on-board charger.

Q: Is the DTC set?

YES : Carry out troubleshooting for the diagnostic trouble code. Then go to Step 4.

NO : Go to Step 4.

STEP 4. Current sensor check

Q: Is the check result normal?

YES : Go to Step 6.

NO : Go to Step 5.

STEP 5. Use scan tool MB991958 to confirm a diagnostic trouble code of other systems.

Check if the DTC is set in the BMU.

Q: Is the DTC set?

YES : Carry out troubleshooting for the DTC.

NO : Intermittent malfunction (Refer to GROUP 00 – How to Use Troubleshooting/Inspection Service Points – How to Cope with Intermittent Malfunctions).

STEP 6. Check whether the DTC is set again.

Check again if the DTC is set in the EV-ECU.

- (1) Erase the DTC.
- (2) Connect the regular charging connector to charge the battery completely.
- (3) Check if the DTC is set.

Q: Is DTC P1B0C or P1B21 set?

YES : Replace the BMU (Refer to [P.54D-188](#)). Then go to Step 7.

NO : Intermittent malfunction (Refer to GROUP 00 – How to Use Troubleshooting/Inspection Service Points – How to Cope with Intermittent Malfunction).

STEP 7. Check whether the DTC is set again.

Check again if the DTC is set in the EV-ECU.

- (1) Erase the DTC.
- (2) Connect the regular charging connector to charge the battery completely.
- (3) Check if the DTC is set.

Q: Is DTC P1B0C or P1B21 set?

YES : Replace the EV-ECU. Then go to Step 8.

NO : The diagnosis is complete.

STEP 8. Check whether the DTC is set again.

Check again if the DTC is set in the EV-ECU.

- (1) Erase the DTC.
- (2) Connect the regular charging connector to charge the battery completely.
- (3) Check if the DTC is set.

Q: Is DTC P1B0C or P1B21 set?

YES : Return to Step 1.

NO : The diagnosis is complete.

DTC P1B0D Quick Charging Over Current

 CAUTION

If there is any problem in the CAN bus lines, an incorrect DTC may be set. Prior to this diagnosis, always diagnose the CAN bus lines (Refer to GROUP 54C – CAN Bus Diagnostics Table).

OPERATION

- The quick charger communicates with EV-ECU via the local CAN (for the quick charger).
- BMU communicates with EV-ECU via CAN.

DTC SET CONDITION

- If the battery current from the BMU is larger than the on board charger current command value by the specified value or more for 5 seconds or longer, DTC P1B0D will be set.

PROBABLE CAUSES

- Malfunction of quick charger
- Malfunction of the BMU
- Malfunction of the EV-ECU
- Malfunction of the current sensor in the main drive lithium-ion battery assembly

DIAGNOSIS

STEP 1. Using scan tool MB991958, diagnose the CAN bus lines.

Use the scan tool to diagnose the CAN bus lines.

Q: Is the check result normal?

YES : Go to Step 3.

NO : Repair the CAN bus line (Refer to GROUP 54C – CAN Bus Diagnostics Table). Then go to Step 2.

STEP 2. DTC recheck after resetting CAN bus lines

Check again if DTC P1B0D is set in the EV-ECU.

(1) Erase the DTC.

(2) Connect the quick charging connector to charge the battery completely.

(3) Check if the DTC is set.

Q: Is the DTC set?

YES : Go to Step 3.

NO : This diagnosis is complete.

STEP 3. Current sensor check**Q: Is the check result normal?**

YES : Go to Step 6.

NO : Go to Step 4.

STEP 4. Use scan tool MB991958 to confirm a diagnostic trouble code of other systems.

Check if the DTC is set in the BMU.

Q: Is the DTC set?

YES : Carry out troubleshooting for the DTC. Then go to Step 5.

NO : Go to Step 5.

STEP 5. Check whether the DTC is set again.

Check again if the DTC is set in the EV-ECU.

(1) Erase the DTC.

(2) Connect the regular charging connector to charge the battery completely.

(3) Check if the DTC is set.

Q: Is DTC P1B0D set?

YES : Check the quick charger. Then go to Step 6.

NO : Intermittent malfunction (Refer to GROUP 00 – How to Use Troubleshooting/Inspection Service Points, How to Cope with Intermittent Malfunctions.).

STEP 6. Check whether the DTC is set again.

Check again if the DTC is set in the EV-ECU.

- (1) Erase the DTC.
- (2) Connect the regular charging connector to charge the battery completely.
- (3) Check if the DTC is set.

Q: Is DTC P1B0D set?

YES : Replace the BMU (Refer to [P.54D-188](#)). Then go to Step 7.

NO : The diagnosis is complete.

STEP 7. Check whether the DTC is set again.

Check again if the DTC is set in the EV-ECU.

- (1) Erase the DTC.
- (2) Connect the regular charging connector to charge the battery completely.
- (3) Check if the DTC is set.

Q: Is DTC P1B0D set?

YES : Replace the EV-ECU. Then go to Step 8.

NO : The diagnosis is complete.

STEP 8. Check whether the DTC is set again.

Check again if the DTC is set in the EV-ECU.

- (1) Erase the DTC.
- (2) Connect the regular charging connector to charge the battery completely.
- (3) Check if the DTC is set.

Q: Is DTC P1B0D set?

YES : Return to Step 1.

NO : The diagnosis is complete.

DTC P1B72 Quick Charger Charging Current 1**⚠ CAUTION**

If there is any problem in the CAN bus lines, an incorrect DTC may be set. Prior to this diagnosis, always diagnose the CAN bus lines (Refer to **GROUP 54C – CAN Bus Diagnostics Table**).

OPERATION

- The quick charger or external power supply equipment communicates with EV-ECU via the local CAN (for the quick charger or external power supply equipment).
- BMU communicates with EV-ECU via CAN.
- Malfunction of the current sensor in the main

DTC SET CONDITION

- If the battery current value, which is transmitted from the BMU, remains special value or more, and the quick charger output current value, which is transmitted from a quick charger or external power supply equipment, remains special value or less for at least 5 seconds, DTC P1B72 will be set.

PROBABLE CAUSES

- Malfunction of wiring harness and connectors (Local CAN (for quick charger or external power supply equipment))
- Malfunction of quick charger or external power supply equipment
- Malfunction of the BMU drive lithium-ion battery

DIAGNOSIS

⚠ DANGER

- ***When high voltage system components are serviced, be sure to remove service plug to shut down high voltage (Refer to GROUP 00 – Precautions Before Service, Precautions on how to use the high-voltage vehicle).***
- ***When removing service plug, wear the specified protective equipment.***

STEP 1. Using scan tool MB991958, diagnose the CAN bus lines.

Use the scan tool to diagnose the CAN bus lines.

Q: Is the check result normal?

YES : Go to Step 3.

NO : Repair the CAN bus line (Refer to GROUP 54C – Troubleshooting). Then go to Step 2.

STEP 2. DTC recheck after resetting CAN bus lines

Check again if DTC P1B72 is set in the EV-ECU.

(1) Erase the DTC.

(2) Connect the quick charging connector or an external power supply equipment to charge or discharge the battery completely.

(3) Check if the DTC is set.

Q: Is the DTC set?

YES : Go to Step 3.

NO : This diagnosis is complete.

STEP 3. Current sensor check

Q: Is the check result normal?

YES : Go to Step 4.

NO : Go to Step 8.

STEP 4. Measure the local CAN (for quick charger or external power supply equipment) terminator resistor

(1) C-111 Disconnect the EV-ECU connector, and measure the resistance at the EV-ECU side.

(2) Connect the quick charger or external power supply equipment.

(3) Measure the resistance between terminal No.101 and No.102.

OK: $120 \pm 20 \Omega$

Q: Is the check result normal?

YES : Go to Step 5.

NO : Replace the EV-ECU.

STEP 5. Measure the local CAN (for quick charger or external power supply equipment) terminator resistor

- (1) C-111 Disconnect the EV-ECU connector, and measure the resistance at the wiring harness side.
- (2) Connect the quick charger or external power supply equipment.
- (3) Measure the resistance between terminal No.101 and No.102.

OK: $120 \pm 20 \Omega$

Q: Is the check result normal?

YES : Go to Step 9.

NO : Go to Step 6.

STEP 6. Check the local CAN (for quick charger or external power supply equipment) bus connector: G-10 quick charger connector, C-111 EV-ECU connector**Q: Is the check result normal?**

YES : Go to Step 7.

NO : Repair the damaged connector.

STEP 7. Check the local CAN (for quick charger or external power supply equipment) bus line between the G-10 quick charging connection terminal No. 8, 9 and C-111 EV-ECU connector terminal No. 101, 102.

Check the signal lines for short to ground or open circuit.

Q: Is the check result normal?

YES : Check the quick charger or external power supply equipment. Then go to Step 9 .

NO : Repair the wiring harness.

STEP 8. Use scan tool MB991958 to confirm a DTC of other systems.

Check if the DTC is set in the BMU.

Q: Is the DTC set?

YES : Carry out troubleshooting for the DTC.

NO : Intermittent malfunction (Refer to GROUP 00 – How to Use Troubleshooting/Inspection Service Points, How to Cope with Intermittent Malfunctions).

STEP 9. Check whether the DTC is set again.

Check again if the DTC is set in the EV-ECU.

- (1) Erase the DTC.
- (2) Connect the quick charging connector or an external power supply equipment to charge or discharge the battery completely.
- (3) Check if the DTC is set.

Q: Is DTC P1B72 set?

YES : Replace the BMU (Refer to [P.54D-188](#)). Then go to Step 10.

NO : The diagnosis is complete.

STEP 10. Check whether the DTC is set again.

Check again if the DTC is set in the EV-ECU.

- (1) Erase the DTC.
- (2) Connect the quick charging connector or an external power supply equipment to charge or discharge the battery completely.
- (3) Check if the DTC is set.

Q: Is DTC P1B72 set?

YES : Return to Step 1.

NO : The diagnosis is complete.

DTC P1B73 Quick Charger Charging Current 2**⚠ CAUTION**

If there is any problem in the CAN bus lines, an incorrect DTC may be set. Prior to this diagnosis, always diagnose the CAN bus lines (Refer to GROUP 54C – CAN Bus Diagnostics Table).

OPERATION

- The quick charger or external power supply equipment communicates with EV-ECU via the local CAN (for the quick charger or external power supply equipment).
- BMU communicates with EV-ECU via CAN.

DTC SET CONDITION

- If the battery current value, which is transmitted from the BMU, remains special value or more, and the quick-charging current value, which the EV-ECU requests to a quick charger or external power supply equipment, remains special value or less for at least 5 seconds, DTC P1B73 will be set.

PROBABLE CAUSES

- Malfunction of wiring harness and connectors (Local CAN (for quick charger or external power supply equipment))
- Malfunction of quick charger or external power supply equipment
- Malfunction of the BMU
- Malfunction of the current sensor in the main drive lithium-ion battery

DIAGNOSIS**⚠ DANGER**

- *When high voltage system components are serviced, be sure to remove service plug to shut down high voltage (Refer to GROUP 00 – Precautions Before Service, Precautions on how to use the high-voltage vehicle).*
- *When removing service plug, wear the specified protective equipment.*

STEP 1. Using scan tool MB991958, diagnose the CAN bus lines

Use the scan tool to diagnose the CAN bus lines.

Q: Is the check result normal?

YES : Go to Step 3.

NO : Repair the CAN bus line (Refer to GROUP 54C – Troubleshooting). Then go to Step 2.

STEP 2. DTC recheck after resetting CAN bus lines

Check again if DTC P1B73 is set in the EV-ECU.

- (1) Erase the DTC.
- (2) Connect the quick charging connector or an external power supply equipment to charge or discharge the battery completely.
- (3) Check if the DTC is set.

Q: Is the DTC set?

YES : Go to Step 3.

NO : This diagnosis is complete.

STEP 3. Current sensor check**Q: Is the check result normal?**

YES : Go to Step 4.

NO : Go to Step 8.

STEP 4. Measure the local CAN (for quick charger or external power supply equipment) terminator resistor

- (1) C-111 Disconnect the EV-ECU connector, and measure the resistance at the EV-ECU side.
- (2) Connect the quick charger or external power supply equipment.
- (3) Measure the resistance between terminal No.101 and No.102.

OK: $120 \pm 20 \Omega$

Q: Is the check result normal?

YES : Go to Step 5.

NO : Replace the EV-ECU.

STEP 5. Measure the local CAN (for quick charger or external power supply equipment) terminator resistor

- (1) C-111 Disconnect the EV-ECU connector, and measure the resistance at the wiring harness side.
- (2) Connect the quick charger or external power supply equipment.
- (3) Measure the resistance between terminal No.101 and No.102.

OK: $120 \pm 20 \Omega$

Q: Is the check result normal?

YES : Go to Step 9.

NO : Go to Step 6.

STEP 6. Check the local CAN (for quick charger or external power supply equipment) bus connector: G-10 quick charger connector, C-111 EV-ECU connector**Q: Is the check result normal?**

YES : Go to Step 7.

NO : Repair the damaged connector.

STEP 7. Check the local CAN (for quick charger or external power supply equipment) bus line between the G-10 quick charging connection terminal No. 8, 9 and C-111 EV-ECU connector terminal No. 101, 102.

Check the signal lines for short to ground or open circuit.

Q: Is the check result normal?

YES : Check the quick charger or external power supply equipment. Then go to Step 9 .

NO : Repair the wiring harness.

STEP 8. Use scan tool MB991958 to confirm a DTC of other systems.

Check if the DTC is set in the BMU.

Q: Is the DTC set?

YES : Carry out troubleshooting for the DTC.

NO : Intermittent malfunction (Refer to GROUP 00 – How to Use Troubleshooting/Inspection Service Points, How to Cope with Intermittent Malfunctions).

STEP 9. Check whether the DTC is set again.

Check again if the DTC is set in the EV-ECU.

(1) Erase the DTC.

(2) Connect the quick charging connector or an external power supply equipment to charge or discharge the battery completely.

(3) Check if the DTC is set.

Q: Is DTC P1B72 set?

YES : Replace the BMU (Refer to [P.54D-188](#)). Then go to Step 10.

NO : The diagnosis is complete.

STEP 10. Check whether the DTC is set again.

Check again if the DTC is set in the EV-ECU.

(1) Erase the DTC.

(2) Connect the quick charging connector or an external power supply equipment to charge or discharge the battery completely.

(3) Check if the DTC is set.

Q: Is DTC P1B72 set?

YES : Return to Step 1.

NO : The diagnosis is complete.

DTC P1B74 Quick Charger Dis-CHG. Current 1

CAUTION

If there is any problem in the CAN bus lines, an incorrect DTC may be set. Prior to this diagnosis, always diagnose the CAN bus lines (Refer to GROUP 54C – CAN Bus Diagnostics Table).

OPERATION

- The quick charger or external power supply equipment communicates with EV-ECU via the local CAN (for the quick charger or external power supply equipment).
- BMU communicates with EV-ECU via CAN.

DTC SET CONDITION

- If the discharging current input value, which is transmitted from a quick charger or external power supply equipment, exceeds the battery current value, which is transmitted from the BMU, by a predetermined value for at least 5 seconds, DTC P1B74 will be set.

PROBABLE CAUSES

- Malfunction of wiring harness and connectors (Local CAN (for quick charger or external power supply equipment))
- Malfunction of quick charger or external power supply equipment
- Malfunction of the BMU
- Malfunction of the current sensor in the main drive lithium-ion battery

DIAGNOSIS** DANGER**

- *When high voltage system components are serviced, be sure to remove service plug to shut down high voltage (Refer to GROUP 00 – Precautions Before Service, Precautions on how to use the high-voltage vehicle).*
- *When removing service plug, wear the specified protective equipment.*

STEP 1. Using scan tool MB991958, diagnose the CAN bus lines.

Use the scan tool to diagnose the CAN bus lines.

Q: Is the check result normal?

YES : Go to Step 3.

NO : Repair the CAN bus line (Refer to GROUP 54C – Troubleshooting). Then go to Step 2.

STEP 2. DTC recheck after resetting CAN bus lines

Check again if DTC P1B74 is set in the EV-ECU.

(1) Erase the DTC.

(2) Connect the quick charging connector or an external power supply equipment to charge or discharge the battery completely.

(3) Check if the DTC is set.

Q: Is the DTC set?

YES : Go to Step 3.

NO : This diagnosis is complete.

STEP 3. Current sensor check**Q: Is the check result normal?**

YES : Go to Step 4.

NO : Go to Step 8.

STEP 4. Measure the local CAN (for quick charger or external power supply equipment) terminator resistor

- (1) C-111 Disconnect the EV-ECU connector, and measure the resistance at the EV-ECU side.
- (2) Connect the quick charger or external power supply equipment.
- (3) Measure the resistance between terminal No.101 and No.102.

OK: $120 \pm 20 \Omega$

Q: Is the check result normal?

YES : Go to Step 5.

NO : Replace the EV-ECU.

STEP 5. Measure the local CAN (for quick charger or external power supply equipment) terminator resistor

- (1) C-111 Disconnect the EV-ECU connector, and measure the resistance at the wiring harness side.
- (2) Connect the quick charger or external power supply equipment.
- (3) Measure the resistance between terminal No.101 and No.102.

OK: $120 \pm 20 \Omega$

Q: Is the check result normal?

YES : Go to Step 9.

NO : Go to Step 6.

STEP 6. Check the local CAN (for quick charger or external power supply equipment) bus connector: G-10 quick charger connector, C-111 EV-ECU connector

Q: Is the check result normal?

YES : Go to Step 7.

NO : Repair the damaged connector.

STEP 7. Check the local CAN (for quick charger or external power supply equipment) bus line between the G-10 quick charging connection terminal No. 8, 9 and C-111 EV-ECU connector terminal No. 101, 102.

Check the signal lines for short to ground or open circuit.

Q: Is the check result normal?

YES : Check the quick charger or external power supply equipment. Then go to Step 9 .

NO : Repair the wiring harness.

STEP 8. Use scan tool MB991958 to confirm a DTC of other systems.

Check if the DTC is set in the BMU.

Q: Is the DTC set?

YES : Carry out troubleshooting for the DTC.

NO : Intermittent malfunction (Refer to GROUP 00 – How to Use Troubleshooting/Inspection Service Points, How to Cope with Intermittent Malfunctions).

STEP 9. Check whether the DTC is set again.

Check again if the DTC is set in the EV-ECU.

(1) Erase the DTC.

(2) Connect the quick charging connector or an external power supply equipment to charge or discharge the battery completely.

(3) Check if the DTC is set.

Q: Is DTC P1B72 set?

YES : Replace the BMU (Refer to [P.54D-188](#)). Then go to Step 10.

NO : The diagnosis is complete.

STEP 10. Check whether the DTC is set again.

Check again if the DTC is set in the EV-ECU.

(1) Erase the DTC.

(2) Connect the quick charging connector or an external power supply equipment to charge or discharge the battery completely.

(3) Check if the DTC is set.

Q: Is DTC P1B72 set?

YES : Return to Step 1.

NO : The diagnosis is complete.

DTC P1B75 Quick Charger Dis-CHG. Current 2**⚠ CAUTION**

If there is any problem in the CAN bus lines, an incorrect DTC may be set. Prior to this diagnosis, always diagnose the CAN bus lines (Refer to GROUP 54C – CAN Bus Diagnostics Table).

OPERATION

- The quick charger or external power supply equipment communicates with EV-ECU via the local CAN (for the quick charger or external power supply equipment).
- BMU communicates with EV-ECU via CAN.

DTC SET CONDITION

- If the battery current value, which is transmitted from the BMU, remains special value or less and the last discharging current input value, which is transmitted from a quick charger or external power supply equipment, remains special value or more for at least 5 seconds, DTC P1B75 will be set.

PROBABLE CAUSES

- Malfunction of wiring harness and connectors (Local CAN (for quick charger or external power supply equipment))
- Malfunction of quick charger or external power supply equipment
- Malfunction of the BMU

- Malfunction of the current sensor in the main drive lithium-ion battery

DIAGNOSIS

DANGER

- ***When high voltage system components are serviced, be sure to remove service plug to shut down high voltage (Refer to GROUP 00 – Precautions Before Service, Precautions on how to use the high-voltage vehicle).***
- ***When removing service plug, wear the specified protective equipment.***

STEP 1. Using scan tool MB991958, diagnose the CAN bus lines.

Use the scan tool to diagnose the CAN bus lines.

Q: Is the check result normal?

YES : Go to Step 3.

NO : Repair the CAN bus line (Refer to GROUP 54C – Troubleshooting). Then go to Step 2.

STEP 2. DTC recheck after resetting CAN bus lines

Check again if DTC P1B75 is set in the EV-ECU.

(1) Erase the DTC.

(2) Connect the quick charging connector or an external power supply equipment to charge or discharge the battery completely.

(3) Check if the DTC is set.

Q: Is the DTC set?

YES : Go to Step 3.

NO : This diagnosis is complete.

STEP 3. Current sensor check

Q: Is the check result normal?

YES : Go to Step 4.

NO : Go to Step 8.

STEP 4. Measure the local CAN (for quick charger or external power supply equipment) terminator resistor

(1) C-111 Disconnect the EV-ECU connector, and measure the resistance at the EV-ECU side.

(2) Connect the quick charger or external power supply equipment.

(3) Measure the resistance between terminal No.101 and No.102.

OK: $120 \pm 20 \Omega$

Q: Is the check result normal?

YES : Go to Step 5.

NO : Replace the EV-ECU.

STEP 5. Measure the local CAN (for quick charger or external power supply equipment) terminator resistor

- (1) C-111 Disconnect the EV-ECU connector, and measure the resistance at the wiring harness side.
- (2) Connect the quick charger or external power supply equipment.
- (3) Measure the resistance between terminal No.101 and No.102.

OK: $120 \pm 20 \Omega$

Q: Is the check result normal?

YES : Go to Step 9.

NO : Go to Step 6.

STEP 6. Check the local CAN (for quick charger or external power supply equipment) bus connector: G-10 quick charger connector, C-111 EV-ECU connector**Q: Is the check result normal?**

YES : Go to Step 7.

NO : Repair the damaged connector.

STEP 7. Check the local CAN (for quick charger or external power supply equipment) bus line between the G-10 quick charging connection terminal No. 8, 9 and C-111 EV-ECU connector terminal No. 101, 102.

Check the signal lines for short to ground or open circuit.

Q: Is the check result normal?

YES : Check the quick charger or external power supply equipment. Then go to Step 9 .

NO : Repair the wiring harness.

STEP 8. Use scan tool MB991958 to confirm a DTC of other systems.

Check if the DTC is set in the BMU.

Q: Is the DTC set?

YES : Carry out troubleshooting for the DTC.

NO : Intermittent malfunction (Refer to GROUP 00 – How to Use Troubleshooting/Inspection Service Points, How to Cope with Intermittent Malfunctions).

STEP 9. Check whether the DTC is set again.

Check again if the DTC is set in the EV-ECU.

- (1) Erase the DTC.
- (2) Connect the quick charging connector or an external power supply equipment to charge or discharge the battery completely.
- (3) Check if the DTC is set.

Q: Is DTC P1B72 set?

YES : Replace the BMU (Refer to [P.54D-188](#)). Then go to Step 10.

NO : The diagnosis is complete.

STEP 10. Check whether the DTC is set again.

Check again if the DTC is set in the EV-ECU.

- (1) Erase the DTC.
- (2) Connect the quick charging connector or an external power supply equipment to charge or discharge the battery completely.
- (3) Check if the DTC is set.

Q: Is DTC P1B72 set?

YES : Return to Step 1.

NO : The diagnosis is complete.

DTC P1B76 Quick Charger Dis-CHG. Current 3**⚠ CAUTION**

If there is any problem in the CAN bus lines, an incorrect DTC may be set. Prior to this diagnosis, always diagnose the CAN bus lines (Refer to GROUP 54C – CAN Bus Diagnostics Table).

OPERATION

- The quick charger or external power supply equipment communicates with EV-ECU via the local CAN (for the quick charger or external power supply equipment).
- BMU communicates with EV-ECU via CAN.

DTC SET CONDITION

- If the discharging upper limit current value, which is transmitted from a quick charger or external power supply equipment, exceeds the battery current value, which is transmitted from the BMU, by a predetermined value for at least 5 seconds, DTC P1B76 will be set.

PROBABLE CAUSES

- Malfunction of wiring harness and connectors (Local CAN (for quick charger or external power supply equipment))
- Malfunction of quick charger or external power supply equipment
- Malfunction of the BMU
- Malfunction of the current sensor in the main drive lithium-ion battery

DIAGNOSIS**⚠ DANGER**

- *When high voltage system components are serviced, be sure to remove service plug to shut down high voltage (Refer to GROUP 00 – Precautions Before Service, Precautions on how to use the high-voltage vehicle).*
- *When removing service plug, wear the specified protective equipment.*

STEP 1. Using scan tool MB991958, diagnose the CAN bus lines.

Use the scan tool to diagnose the CAN bus lines.

Q: Is the check result normal?

YES : Go to Step 3.

NO : Repair the CAN bus line (Refer to GROUP 54C – Troubleshooting). Then go to Step 2.

STEP 2. DTC recheck after resetting CAN bus lines

Check again if DTC P1B76 is set in the EV-ECU.

- (1) Erase the DTC.
- (2) Connect the quick charging connector or an external power supply equipment to charge or discharge the battery completely.
- (3) Check if the DTC is set.

Q: Is the DTC set?

YES : Go to Step 3.

NO : This diagnosis is complete.

STEP 3. Current sensor check**Q: Is the check result normal?**

YES : Go to Step 4.

NO : Go to Step 8.

STEP 4. Measure the local CAN (for quick charger or external power supply equipment) terminator resistor

- (1) C-111 Disconnect the EV-ECU connector, and measure the resistance at the EV-ECU side.
- (2) Connect the quick charger or external power supply equipment.
- (3) Measure the resistance between terminal No.101 and No.102.

OK: $120 \pm 20 \Omega$

Q: Is the check result normal?

YES : Go to Step 5.

NO : Replace the EV-ECU.

STEP 5. Measure the local CAN (for quick charger or external power supply equipment) terminator resistor

- (1) C-111 Disconnect the EV-ECU connector, and measure the resistance at the wiring harness side.
- (2) Connect the quick charger or external power supply equipment.
- (3) Measure the resistance between terminal No.101 and No.102.

OK: $120 \pm 20 \Omega$

Q: Is the check result normal?

YES : Go to Step 9.

NO : Go to Step 6.

STEP 6. Check the local CAN (for quick charger or external power supply equipment) bus connector: G-10 quick charger connector, C-111 EV-ECU connector**Q: Is the check result normal?**

YES : Go to Step 7.

NO : Repair the damaged connector.

STEP 7. Check the local CAN (for quick charger or external power supply equipment) bus line between the G-10 quick charging connection terminal No. 8, 9 and C-111 EV-ECU connector terminal No. 101, 102.

Check the signal lines for short to ground or open circuit.

Q: Is the check result normal?

YES : Check the quick charger or external power supply equipment. Then go to Step 9 .

NO : Repair the wiring harness.

STEP 8. Use scan tool MB991958 to confirm a DTC of other systems.

Check if the DTC is set in the BMU.

Q: Is the DTC set?

YES : Carry out troubleshooting for the DTC .

NO : Intermittent malfunction (Refer to GROUP 00 – How to Use Troubleshooting/Inspection Service Points, How to Cope with Intermittent Malfunctions).

STEP 9. Check whether the DTC is set again.

Check again if the DTC is set in the EV-ECU.

(1) Erase the DTC.

(2) Connect the quick charging connector or an external power supply equipment to charge or discharge the battery completely.

(3) Check if the DTC is set.

Q: Is DTC P1B76 set?

YES : Replace the BMU (Refer to [P.54D-188](#)). Then go to Step 10.

NO : The diagnosis is complete.

STEP 10. Check whether the DTC is set again.

Check again if the DTC is set in the EV-ECU.

(1) Erase the DTC.

(2) Connect the quick charging connector or an external power supply equipment to charge or discharge the battery completely.

(3) Check if the DTC is set.

Q: Is DTC P1B76 set?

YES : Return to Step 1.

NO : The diagnosis is complete.

DTC P1B77 Quick Charger Dis-CHG. Current 4

 **CAUTION**

If there is any problem in the CAN bus lines, an incorrect DTC may be set. Prior to this diagnosis, always diagnose the CAN bus lines (Refer to GROUP 54C – CAN Bus Diagnostics Table).

OPERATION

- The quick charger or external power supply equipment communicates with EV-ECU via the local CAN (for the quick charger or external power supply equipment).
- BMU communicates with EV-ECU via CAN.

DTC SET CONDITION

- If the battery current value, which is transmitted from the BMU, remains special value or less and the last discharging upper limit current value, which is transmitted from a quick charger or external power supply equipment, remains special value or more for at least 5 seconds, DTC P1B77 will be set.

PROBABLE CAUSES

- Malfunction of wiring harness and connectors (Local CAN (for quick charger or external power supply equipment))
- Malfunction of quick charger or external power supply equipment
- Malfunction of the BMU
- Malfunction of the current sensor in the main drive lithium-ion battery

DIAGNOSIS** DANGER**

- *When high voltage system components are serviced, be sure to remove service plug to shut down high voltage (Refer to GROUP 00 – Precautions Before Service, Precautions on how to use the high-voltage vehicle).*
- *When removing service plug, wear the specified protective equipment.*

STEP 1. Using scan tool MB991958, diagnose the CAN bus lines.

Use the scan tool to diagnose the CAN bus lines.

Q: Is the check result normal?

YES : Go to Step 3.

NO : Repair the CAN bus line (Refer to GROUP 54C – Troubleshooting). Then go to Step 2.

STEP 2. DTC recheck after resetting CAN bus lines

Check again if DTC P1B77 is set in the EV-ECU.

(1) Erase the DTC.

(2) Connect the quick charging connector or an external power supply equipment to charge or discharge the battery completely.

(3) Check if the DTC is set.

Q: Is the DTC set?

YES : Go to Step 3.

NO : This diagnosis is complete.

STEP 3. Current sensor check**Q: Is the check result normal?**

YES : Go to Step 4.

NO : Go to Step 8.

STEP 4. Measure the local CAN (for quick charger or external power supply equipment) terminator resistor

- (1) C-111 Disconnect the EV-ECU connector, and measure the resistance at the EV-ECU side.
- (2) Connect the quick charger or external power supply equipment.
- (3) Measure the resistance between terminal No.101 and No.102.

OK: $120 \pm 20 \Omega$

Q: Is the check result normal?

YES : Go to Step 5.

NO : Replace the EV-ECU.

STEP 5. Measure the local CAN (for quick charger or external power supply equipment) terminator resistor

- (1) C-111 Disconnect the EV-ECU connector, and measure the resistance at the wiring harness side.
- (2) Connect the quick charger or external power supply equipment.
- (3) Measure the resistance between terminal No.101 and No.102.

OK: $120 \pm 20 \Omega$

Q: Is the check result normal?

YES : Go to Step 9.

NO : Go to Step 6.

STEP 6. Check the local CAN (for quick charger or external power supply equipment) bus connector: G-10 quick charger connector, C-111 EV-ECU connector

Q: Is the check result normal?

YES : Go to Step 7.

NO : Repair the damaged connector.

STEP 7. Check the local CAN (for quick charger or external power supply equipment) bus line between the G-10 quick charging connection terminal No. 8, 9 and C-111 EV-ECU connector terminal No. 101, 102.

Check the signal lines for short to ground or open circuit.

Q: Is the check result normal?

YES : Check the quick charger or external power supply equipment. Then go to Step 9 .

NO : Repair the wiring harness.

STEP 8. Use scan tool MB991958 to confirm a DTC of other systems.

Check if the DTC is set in the BMU.

Q: Is the DTC set?

YES : Carry out troubleshooting for the DTC.

NO : Intermittent malfunction (Refer to GROUP 00 – How to Use Troubleshooting/Inspection Service Points, How to Cope with Intermittent Malfunctions).

STEP 9. Check whether the DTC is set again.

Check again if the DTC is set in the EV-ECU.

(1) Erase the DTC.

(2) Connect the quick charging connector or an external power supply equipment to charge or discharge the battery completely.

(3) Check if the DTC is set.

Q: Is DTC P1B77 set?

YES : Replace the BMU (Refer to [P.54D-188](#)). Then go to Step 10.

NO : The diagnosis is complete.

STEP 10. Check whether the DTC is set again.

Check again if the DTC is set in the EV-ECU.

(1) Erase the DTC.

(2) Connect the quick charging connector or an external power supply equipment to charge or discharge the battery completely.

(3) Check if the DTC is set.

Q: Is DTC P1B77 set?

YES : Return to Step 1.

NO : The diagnosis is complete.

DTC P1B78 Quick Charger Received Current**⚠ CAUTION**

If there is any problem in the CAN bus lines, an incorrect DTC may be set. Prior to this diagnosis, always diagnose the CAN bus lines (Refer to GROUP 54C – CAN Bus Diagnostics Table).

OPERATION

- The quick charger or external power supply equipment communicates with EV-ECU via the local CAN (for the quick charger or external power supply equipment).
- BMU communicates with EV-ECU via CAN.

DTC SET CONDITION

- If the quick charger output current value, which is transmitted from a quick charger or external power supply equipment, and the last discharging current input value remain 0.5 A or more for at least 5 seconds, DTC P1B78 will be set.

PROBABLE CAUSES

- Malfunction of wiring harness and connectors (Local CAN (for quick charger or external power supply equipment))
- Malfunction of quick charger or external power supply equipment
- Malfunction of the BMU
- Malfunction of the current sensor in the main drive lithium-ion battery

DIAGNOSIS

⚠ DANGER

- ***When high voltage system components are serviced, be sure to remove service plug to shut down high voltage (Refer to GROUP 00 – Precautions Before Service, Precautions on how to use the high-voltage vehicle).***
- ***When removing service plug, wear the specified protective equipment.***

STEP 1. Using scan tool MB991958, diagnose the CAN bus lines.

Use the scan tool to diagnose the CAN bus lines.

Q: Is the check result normal?

YES : Go to Step 3.

NO : Repair the CAN bus line (Refer to GROUP 54C – Troubleshooting). Then go to Step 2.

STEP 2. DTC recheck after resetting CAN bus lines

Check again if DTC P1B78 is set in the EV-ECU.

- (1) Erase the DTC.
- (2) Connect the quick charging connector or an external power supply equipment to charge or discharge the battery completely.
- (3) Check if the DTC is set.

Q: Is the DTC set?

YES : Go to Step 3.

NO : This diagnosis is complete.

STEP 3. Current sensor check

Q: Is the check result normal?

YES : Go to Step 4.

NO : Go to Step 8.

STEP 4. Measure the local CAN (for quick charger or external power supply equipment) terminator resistor

- (1) C-111 Disconnect the EV-ECU connector, and measure the resistance at the EV-ECU side.
- (2) Connect the quick charger or external power supply equipment.
- (3) Measure the resistance between terminal No.101 and No.102.

OK: $120 \pm 20 \Omega$

Q: Is the check result normal?

YES : Go to Step 5.

NO : Replace the EV-ECU.

STEP 5. Measure the local CAN (for quick charger or external power supply equipment) terminator resistor

- (1) C-111 Disconnect the EV-ECU connector, and measure the resistance at the wiring harness side.
- (2) Connect the quick charger or external power supply equipment.
- (3) Measure the resistance between terminal No.101 and No.102.

OK: $120 \pm 20 \Omega$

Q: Is the check result normal?

YES : Go to Step 9.

NO : Go to Step 6.

STEP 6. Check the local CAN (for quick charger or external power supply equipment) bus connector: G-10 quick charger connector, C-111 EV-ECU connector**Q: Is the check result normal?**

YES : Go to Step 7.

NO : Repair the damaged connector.

STEP 7. Check the local CAN (for quick charger or external power supply equipment) bus line between the G-10 quick charging connection terminal No. 8, 9 and C-111 EV-ECU connector terminal No. 101, 102.

Check the signal lines for short to ground or open circuit.

Q: Is the check result normal?

YES : Check the quick charger or external power supply equipment. Then go to Step 9 .

NO : Repair the wiring harness.

STEP 8. Use scan tool MB991958 to confirm a DTC of other systems.

Check if the DTC is set in the BMU.

Q: Is the DTC set?

YES : Carry out troubleshooting for the DTC.

NO : Intermittent malfunction (Refer to GROUP 00 – How to Use Troubleshooting/Inspection Service Points, How to Cope with Intermittent Malfunctions).

STEP 9. Check whether the DTC is set again.

Check again if the DTC is set in the EV-ECU.

- (1) Erase the DTC.
- (2) Connect the quick charging connector or an external power supply equipment to charge or discharge the battery completely.
- (3) Check if the DTC is set.

Q: Is DTC P1B78 set?

YES : Replace the BMU (Refer to [P.54D-188](#)). Then go to Step 10.

NO : The diagnosis is complete.

STEP 10. Check whether the DTC is set again.

Check again if the DTC is set in the EV-ECU.

- (1) Erase the DTC.
- (2) Connect the quick charging connector or an external power supply equipment to charge or discharge the battery completely.
- (3) Check if the DTC is set.

Q: Is DTC P1B78 set?

YES : Return to Step 1.

NO : The diagnosis is complete.

DTC U111C BMU CAN Timeout

⚠ CAUTION

If there is any problem in the CAN bus lines, an incorrect DTC may be set. Prior to this diagnosis, always diagnose the CAN bus lines (Refer to GROUP 54C – CAN Bus Diagnostics Table).

OPERATION

- BMU communicates with EV-ECU via CAN.

DTC SET CONDITION

- When the timeout of the BMU CAN data is determined, DTC U111C will be set.

PROBABLE CAUSES

- Damaged wiring harness or connector(s)
- Malfunction of the BMU CAN data system

DIAGNOSIS

STEP 1. Using scan tool MB991958, diagnose the CAN bus lines.

Use the scan tool to diagnose the CAN bus lines.

Q: Is the check result normal?

YES : Go to Step 3.

NO : Repair the CAN bus line (Refer to GROUP 54C – CAN Bus Diagnostics Table). Then go to Step 2.

STEP 2. DTC recheck after resetting CAN bus lines

Check again if DTC U111C is set in the EV-ECU.

- (1) Erase the DTC.
- (2) Turn the electric motor switch from LOCK(OFF) position to ON position.
- (3) Check if the DTC is set.

Q: Is the DTC set?

YES : Go to Step 3.

NO : This diagnosis is complete.

STEP 3. Use scan tool MB991958 to confirm a DTC of other systems.

Check if the DTC is set in the BMU.

Q: Is the DTC set?

YES : Carry out troubleshooting for the BMU.

NO : Go to Step 4.

STEP 4. Use scan tool MB991958 to confirm a DTC of other systems.

Check if DTC U111C is set in the compressor & heater controller.

Q: Is the DTC set?

YES : Go to Step 5.

NO : Go to Step 6.

STEP 5. Check whether the DTC is set again.

Check again if the DTC is set in the EV-ECU.

(1) Erase the DTC.

(2) Turn the electric motor switch from LOCK(OFF) position to ON position.

(3) Check if the DTC is set.

Q: Is DTC U111C set?

YES : Replace the BMU (Refer to [P.54D-188](#)).

NO : A poor connection, open circuit of the wiring harness or other intermittent malfunction is present in the CAN bus line between the BMU and EV-ECU (Refer to GROUP 00 – How to Use Troubleshooting/Inspection Service Points, How to Handle Intermittent Malfunctions).

STEP 6. Check whether the DTC is set again.

Check again if the DTC is set in the EV-ECU.

(1) Erase the DTC.

(2) Turn the electric motor switch from LOCK(OFF) position to ON position.

(3) Check if the DTC is set.

Q: Is DTC U111C set?

YES : Replace the EV-ECU.

NO : A poor connection, open circuit of the wiring harness or other intermittent malfunction is present in the CAN bus line between the BMU and EV-ECU (Refer to GROUP 00 – How to Use Troubleshooting/Inspection Service Points, How to Handle Intermittent Malfunctions).

ELECTRIC MOTOR CONTROL UNIT (EMCU) AND MOTOR (ELECTRIC MOTOR UNIT)

DIAGNOSTIC TROUBLE CODE CHART

EMCU

M1549300600261

DTC	Diagnostic item	Reference page
P0A0D	Motor drive VOLT. high (HW detect)	P.54D-99

DIAGNOSTIC TROUBLE CODE PROCEDURES

DTC P0A0D Motor Drive VOLT. High (HW detect)

⚠ CAUTION

- Even when the vehicle is normal, a DTC might be stored depending on the service status. Therefore, check the interview information before the diagnosis.

DTC SET CONDITION

If the motor (electric motor unit) drive voltage increases to approximately 420 V or more, the EMCU will store DTC P0A0D.

PROBABLE CAUSES

- Malfunction of the high-voltage fuse No.1 (Main, 280A) (Main drive lithium-ion battery assembly)
- Bus bar in the main drive lithium-ion battery looseness
- Malfunction of the BMU
- open circuit in the high-voltage circuit or connection looseness
- Malfunction of the EV-ECU
- Malfunction of the EMCU

DIAGNOSIS

STEP 1. Use scan tool MB991958 to confirm a DTC of other systems

Check if the DTC other than P1A22 is stored in the EV-ECU.

Q: Is the DTC stored?

YES : Carry out troubleshooting for the EV-ECU. Then go to Step 2.

NO : Go to Step 2.

STEP 2. Use scan tool MB991958, check freeze frame (FFD) data

Check the freeze frame data.

Freeze frame data

- Item No. 33: Condenser voltage

OK: The difference between the condenser voltage and total battery voltage is 20 V or less.

Q: Is the check result normal?

YES : Go to Step 6.

NO : Go to Step 3.

STEP 3. High-voltage fuse No.1 (Main,280A) (Main drive lithium-ion battery assembly) check

Check the high-voltage fuse No.1 (Main, 280A).

Q: Is the check result normal?

YES : Go to Step 4.

NO : Replace the high-voltage fuse No.1 (Main, 280A). Then go to Step 7.

STEP 4. High-voltage connector check: G-05, G-06 inverter high-voltage terminal, G-18, G-19 main drive lithium-ion battery high-voltage terminal

 DANGER

- **Check the high-voltage circuit while reading carefully the precautions on handling a high-voltage vehicle.**
- **Wear the specified protection equipment during the check.**

- (1) Shut down the high voltage.
- (2) Check that the following terminals are tightened to the specified torque.
 - G-05, G-06 inverter high-voltage terminal
 - G-18, G-19 main drive lithium-ion battery high-voltage terminal

Q: Is the check result normal?

YES : Go to Step 5.

NO : Tighten the high-voltage terminal to the specified torque.

STEP 5. Check the bus bar in main drive lithium-ion battery

- (1) Main drive lithium-ion battery cover removal and installation (Refer to [P.54D-194](#)).
- (2) Air duct removal and installation (Refer to [P.54D-196](#)).
- (3) Pad removal and installation (Refer to [P.54D-196](#)).
- (4) Check whether the bus bar in the main drive lithium-ion battery is tightened correctly (Refer to [P.54D-197](#)).

Q: Is the check result normal?

YES : Go to Step 6.

NO : Retighten the bus bar in the main drive lithium-ion battery (Refer to [P.54D-197](#)). Then go to Step 7.

STEP 6. Check whether the DTC is stored again

Check again if the DTC is stored in the EMCU.

- (1) Erase the stored DTC.
- (2) Set the electric motor switch from the "LOCK" (OFF) position to the "ON" position.
- (3) Set the electric motor switch to the "START" position, and start the electric motor unit.
- (4) Run the vehicle.
- (5) Check if the DTC is stored.

Q: Is DTC P0A0D stored?

YES : Replace the inverter. Then go to Step 7.

NO : The diagnosis is complete.

STEP 7. Check whether the DTC is stored again

Check again if the DTC is stored in the ECU.

- (1) Erase the stored DTC.
- (2) Set the electric motor switch from the "LOCK" (OFF) position to the "ON" position.
- (3) Set the electric motor switch to the "START" position, and start the electric motor unit.
- (4) Run the vehicle.
- (5) Check if the DTC is stored.

Q: Is DTC P0A0D stored?

YES : Return to Step 1.





NO : The diagnosis is complete.

BATTERY MANAGEMENT UNIT (BMU) AND MAIN DRIVE LITHIUM-ION BATTERY

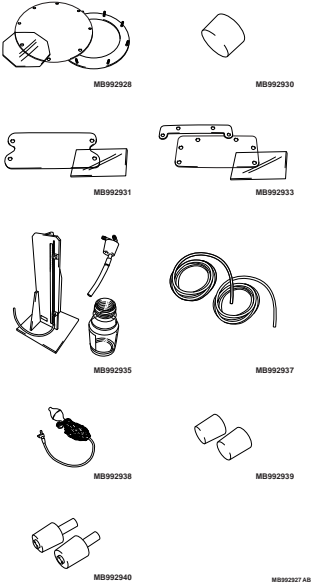
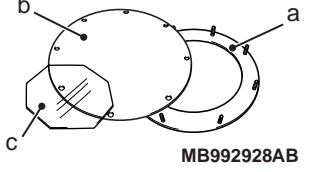
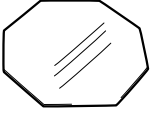
SPECIAL TOOLS

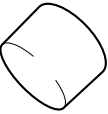
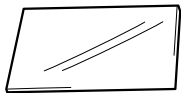
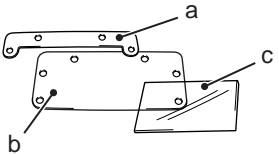
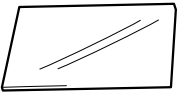
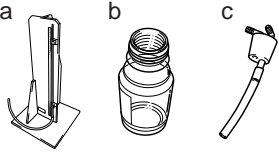
M1549400200107

Tool	Tool number and name	Supersession	Application
	MB992927 Battery air leak check tool kit	-	Air leak check of the Main Drive Lithium-ion Battery <i>NOTE: Air leak check tool set</i>
	MB992928 Service plug cover a. Plate A b. Plate B c. Silicone rubber	-	Air leak check of the Main Drive Lithium-ion Battery
	MB992929 Service plug gasket	-	Air leak check of the Main Drive Lithium-ion Battery <i>NOTE: Silicone rubber of special tool service plug cover (MB992928)</i>

Tool	Tool number and name	Supersession	Application
 <p>MB992930</p>	MB992930 Plug (67 – 74)	–	Air leak check of the Main Drive Lithium-ion Battery
 <p>MB992932</p>	MB992932 Duct gasket A	–	Air leak check of the Main Drive Lithium-ion Battery <i>NOTE: Silicone rubber of special tool dust cover A (MB992931)</i>
 <p>MB992933AB</p>	MB992933 Duct cover B a. Plate A b. Plate B c. Silicone rubber	–	Air leak check of the Main Drive Lithium-ion Battery
 <p>MB992934</p>	MB992934 Duct gasket B	–	Air leak check of the Main Drive Lithium-ion Battery <i>NOTE: Silicone rubber of special tool dust cover B (MB992933)</i>
 <p>MB992935AB</p>	MB992935 Pressure gauge unit a. Measuring bench b. Bottle c. Rubber plug with nipple	–	Air leak check of the Main Drive Lithium-ion Battery
 <p>MB992936</p>	MB992936 Nipple (29 – 35)	–	Air leak check of the Main Drive Lithium-ion Battery <i>NOTE: Rubber plug with nipple included in special tool pressure gauge unit (MB992935)</i>
 <p>MB992937</p>	MB992937 Hose (6)	–	Air leak check of the Main Drive Lithium-ion Battery
 <p>MB992938</p>	MB992938 Air pump	–	Air leak check of the Main Drive Lithium-ion Battery

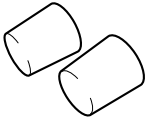
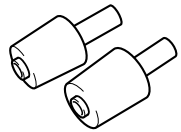
Tool	Tool number and name	Supersession	Application
 <p>MB992939</p>	MB992939 Plug (23 – 27.5)	–	Air leak check of the Main Drive Lithium-ion Battery
 <p>MB992940</p>	MB992940 Nipple (19 – 22)	–	Air leak check of the Main Drive Lithium-ion Battery

RECOMMENDED TOOLS

M1549406200053

The following recommended tools are necessary when you proceed to the operations following the air leak check without mounting the main drive lithium-ion battery after it is disassembled and assembled. If the recommended tools are not available, mount the main drive lithium-ion battery before you proceed to the operations following the air leak check.

Number	Name	Use
MB992959	PN line extra harness	Extended wiring harness wires which allow you to perform the following operations without mounting the main drive lithium-ion battery. <ul style="list-style-type: none"> • Numbering the CMU • main drive lithium-ion battery capacity measurement
MB992752	Control line extra harness	
MB992753	Ground extra harness	
MB992907	A/C extra harness	

How to use

Use the recommended tools to connect the main drive lithium-ion battery to the vehicle as shown.

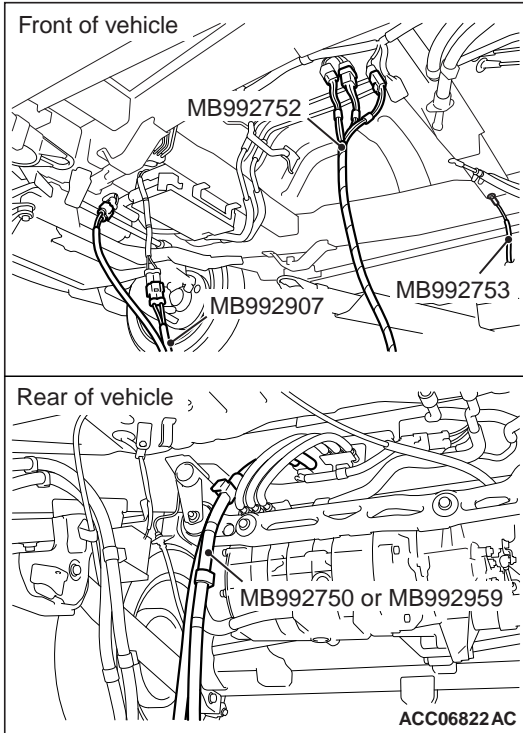

INSPECTION CHART FOR DIAGNOSTIC TROUBLE
 CODE

M1549400600387

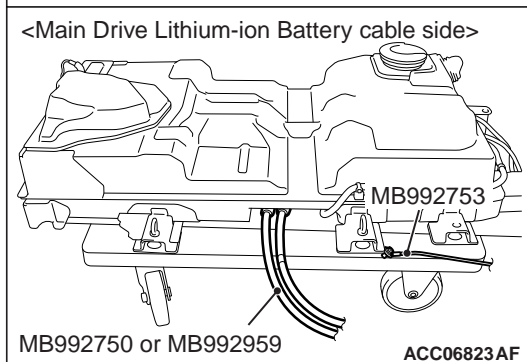
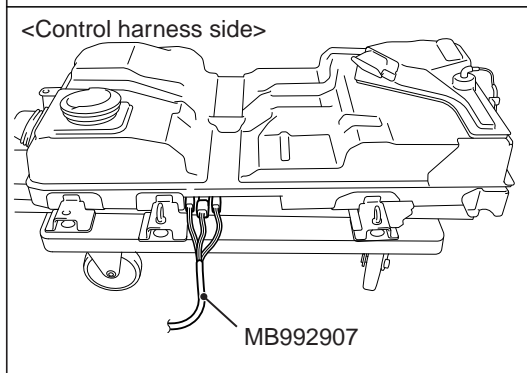
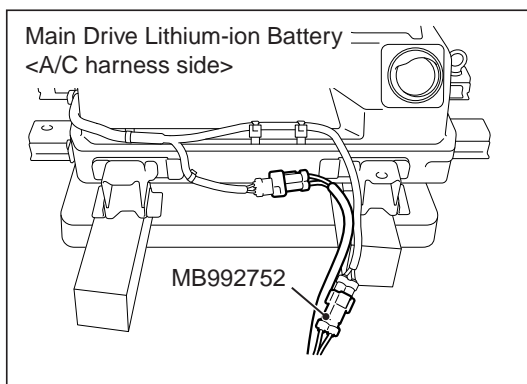

Code No.	Diagnosis item	Reference page
P1A40	Battery current sensor ($\pm 350A$)	P.54D-108
P1A41	Battery current sensor ($\pm 30A$)	P.54D-110
P1A42	BATT. current SNS. power circuit	P.54D-112
P1A43	BATT. current SNS. detect circuit	P.54D-113
P1A44	Leak detection (BMU)	P.54D-115
P1A46	Leak sensor detection circuit	P.54D-130
P1A48	BATT. cooling fan output circuit	P.54D-132
P1A6A	CMU01 Battery temperature	P.54D-134
P1A6B	CMU02 Battery temperature	P.54D-134
P1A6C	CMU03 Battery temperature	P.54D-134
P1A6D	CMU04 Battery temperature	P.54D-134
P1A6E	CMU05 Battery temperature	P.54D-134
P1A6F	CMU06 Battery temperature	P.54D-134
P1A70	CMU07 Battery temperature	P.54D-134

Code No.	Diagnosis item	Reference page
P1A71	CMU08 Battery temperature	P.54D-134
P1A72	CMU09 Battery temperature	P.54D-134
P1A73	CMU10 Battery temperature	P.54D-134
P1A74	CMU11 Battery temperature	P.54D-134
P1A75	CMU12 Battery temperature	P.54D-134
P1A76	CMU01 Cell voltage sensor	P.54D-136
P1A77	CMU02 Cell voltage sensor	P.54D-136
P1A78	CMU03 Cell voltage sensor	P.54D-136
P1A79	CMU04 Cell voltage sensor	P.54D-136
P1A7A	CMU05 Cell voltage sensor	P.54D-136
P1A7B	CMU06 Cell voltage sensor	P.54D-136
P1A7C	CMU07 Cell voltage sensor	P.54D-136
P1A7D	CMU08 Cell voltage sensor	P.54D-136
P1A7E	CMU09 Cell voltage sensor	P.54D-136
P1A7F	CMU10 Cell voltage sensor	P.54D-136
P1A80	CMU11 Cell voltage sensor	P.54D-136
P1A81	CMU12 Cell voltage sensor	P.54D-136
P1A82	CMU01 Battery temperature sensor	P.54D-138
P1A83	CMU02 Battery temperature sensor	P.54D-138
P1A84	CMU03 Battery temperature sensor	P.54D-138
P1A85	CMU04 Battery temperature sensor	P.54D-138
P1A86	CMU05 Battery temperature sensor	P.54D-138
P1A87	CMU06 Battery temperature sensor	P.54D-138
P1A88	CMU07 Battery temperature sensor	P.54D-138
P1A89	CMU08 Battery temperature sensor	P.54D-138
P1A8A	CMU09 Battery temperature sensor	P.54D-138
P1A8B	CMU10 Battery temperature sensor	P.54D-138
P1A8C	CMU11 Battery temperature sensor	P.54D-138
P1A8D	CMU12 Battery temperature sensor	P.54D-138
P1A8E	CMU01 Battery balancing unit	P.54D-139
P1A8F	CMU02 Battery balancing unit	P.54D-139
P1A90	CMU03 Battery balancing unit	P.54D-139
P1A91	CMU04 Battery balancing unit	P.54D-139
P1A92	CMU05 Battery balancing unit	P.54D-139
P1A93	CMU06 Battery balancing unit	P.54D-139
P1A94	CMU07 Battery balancing unit	P.54D-139
P1A95	CMU08 Battery balancing unit	P.54D-139

Code No.	Diagnosis item	Reference page
P1A96	CMU09 Battery balancing unit	P.54D-139
P1A97	CMU10 Battery balancing unit	P.54D-139
P1A98	CMU11 Battery balancing unit	P.54D-139
P1A99	CMU12 Battery balancing unit	P.54D-139
P1AA8	Local CAN (for Main Drive Lithium-ion Battery) signal time-out	P.54D-140
P1AA9	Cell number mismatch	P.54D-146
P1AB5	CMU01 Battery low temperature	P.54D-147
P1AB6	CMU02 Battery low temperature	P.54D-147
P1AB7	CMU03 Battery low temperature	P.54D-147
P1AB8	CMU04 Battery low temperature	P.54D-147
P1AB9	CMU05 Battery low temperature	P.54D-147
P1ABA	CMU06 Battery low temperature	P.54D-147
P1ABB	CMU07 Battery low temperature	P.54D-147
P1ABC	CMU08 Battery low temperature	P.54D-147
P1ABD	CMU09 Battery low temperature	P.54D-147
P1ABE	CMU10 Battery low temperature	P.54D-147
P1ABF	CMU11 Battery low temperature	P.54D-147
P1AC0	CMU12 Battery low temperature	P.54D-147
P1AC1	Battery cooling fan (Drive fail)	P.54D-148
P1AC2	Battery cooling fan (SHT to BAT)	P.54D-152
P1AC3	Battery cooling fan (Rest fail)	P.54D-156
P1AC6	Each Cell VOLT. diff. (Hi side)	P.54D-159
P1ADF	+B line voltage	P.54D-161
P1AE0	Clock IC time counter	P.54D-163
P1AE1	Clock IC alarm	P.54D-164
P1AE3	BMU TEMP. sensor (Open/Short)	P.54D-165
P1AE4	BMU TEMP. sensor (Rationality)	P.54D-165
U1082	Bat-CAN Bus-off	P.54D-166
U11A0	CMU01 CAN timeout	P.54D-169
U11A1	CMU02 CAN timeout	P.54D-169
U11A2	CMU03 CAN timeout	P.54D-169
U11A3	CMU04 CAN timeout	P.54D-169
U11A4	CMU05 CAN timeout	P.54D-169
U11A5	CMU06 CAN timeout	P.54D-169
U11A6	CMU07 CAN timeout	P.54D-169
U11A7	CMU08 CAN timeout	P.54D-169
U11A8	CMU09 CAN timeout	P.54D-169

Code No.	Diagnosis item	Reference page
U11A9	CMU10 CAN timeout	P.54D-169
U11AA	CMU11 CAN timeout	P.54D-169
U11AB	CMU12 CAN timeout	P.54D-169
U1925	CMU ID numbering reception error	P.54D-175
U1926	EV-ECU V-CAN error	P.54D-179

DIAGNOSTIC CODE PROCEDURES

DTC P1A40 Battery Current Sensor ($\pm 350A$)

TROUBLE JUDGMENT

Check Conditions

- The electric motor switch is ON position or while the main drive lithium-ion battery is charged.
- The following diagnostic trouble code is not set.
 - a. P1A42: BATT. circuit SNS. power circuit

Judgment Criterion

- The output voltage of the main drive lithium-ion battery current sensor (high) is less than 0.2 volt.

or

- The output voltage of the main drive lithium-ion battery current sensor (high) is more than 4.8 volts.

FAIL-SAFE AND BACKUP FUNCTION

- The system turns OFF the balancer drive.
- The energy level gauge displays the 0 segment.

PROBABLE CAUSES

- The main drive lithium-ion battery current sensor is failed.
- Open circuits of main drive lithium-ion battery current sensor circuit, short circuits to ground, short circuits to power supply system or damage; poor contact of connector.
- The BMU is failed.

DIAGNOSIS

STEP 1. Scan tool MB991958 data list

- Refer to Data List Reference Table.
- Item 12: battery current
- Item 13: BAT. current HI control value

Q: Is the check result normal?

YES : Intermittent malfunction (Refer to GROUP 00 – How to Use Troubleshooting/Inspection Service Points, How to Cope with Intermittent Malfunctions).

NO : Go to Step 2.

STEP 2. Connector check: BMU connector and main drive lithium-ion battery electric current sensor connector
 Removal the main drive lithium-ion battery cover (Refer to [P.54D-194](#)).

Q: Is the check result normal?

- YES** : Go to Step 3.
- NO** : Repair the connector.

STEP 3. Check the wiring harness between BMU connector (terminal No.7, 6, 22, 8) and main drive lithium-ion battery electric current sensor connector (terminal No.1, 2, 3, 4)
 Check power supply or signal line for open or short circuit.

Q: Is the check result normal?

- YES** : Go to Step 4.
- NO** : Repair the wiring harness.

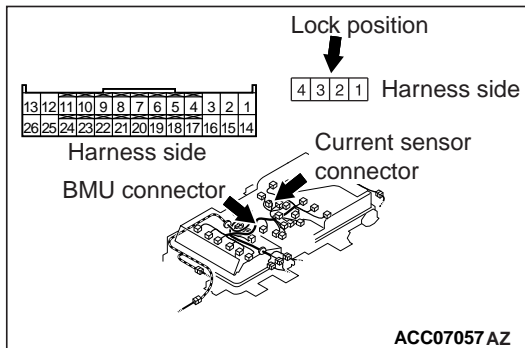

STEP 4. Perform resistance measurement at BMU connector

- Disconnect connector, and measure at BMU side.
- Resistance between terminal No.3 and No.21, No.22.

OK: Continuity (2 Ω or less)

Q: Is the check result normal?

- YES** : Go to Step 5.
- NO** : Replace the BMU (Refer to [P.54D-188](#)). Then go to Step 5 .

STEP 5. Check the current sensor in main drive lithium-ion battery

- (1) Removal the current sensor in main drive lithium-ion battery (Refer to [P.54D-207](#)).
- (2) Check the current sensor in main drive lithium-ion battery (Refer to [P.54D-218](#)).

Q: Is the check result normal?

- YES** : Go to Step 6.
- NO** : Replace the current sensor in main drive lithium-ion battery (Refer to [P.54D-207](#)).

STEP 6. Use scan tool MB991958 to confirm a diagnostic trouble code.

Q: Is the diagnostic trouble code set?

YES : Replace the BMU (Refer to [P.54D-188](#)).

NO : Intermittent malfunction (Refer to GROUP 00 – How to Use Troubleshooting/Inspection Service Points, How to Cope with Intermittent Malfunctions).

DTC P1A41 Battery Current Sensor ($\pm 30A$)

TROUBLE JUDGMENT

Check Conditions

- The electric motor switch is ON position or while the main drive lithium-ion battery is charged.
- The following diagnostic trouble code is not set.
 - a. P1A42: BATT. circuit SNS. power circuit

Judgment Criterion

- The output voltage of the main drive lithium-ion battery current sensor (low) is less than 0.2 volt.

or

- The output voltage of the main drive lithium-ion battery current sensor (low) is more than 4.8 volts.

FAIL-SAFE AND BACKUP FUNCTION

- Use the main drive lithium-ion battery current sensor (high) to control and turn off the balancer drive when the main drive lithium-ion battery current sensor (high) is normal.

PROBABLE CAUSES

- The main drive lithium-ion battery current sensor is failed.
- Open circuits of main drive lithium-ion battery current sensor circuit, short circuits to ground, short circuits to power supply system or damage; poor contact of connector.
- The BMU is failed.

DIAGNOSIS

STEP 1. Scan tool MB991958 data list

- Refer to Data List Reference Table.
- Item 12: battery current
- Item 14: BAT. current LO control value

Q: Is the check result normal?

YES : Intermittent malfunction (Refer to GROUP 00 – How to Use Troubleshooting/Inspection Service Points, How to Cope with Intermittent Malfunctions).

NO : Go to Step 2.

STEP 2. Connector check: BMU connector and main drive lithium-ion battery electric current sensor connector

Removal the main drive lithium-ion battery cover (Refer to [P.54D-194](#)).

Q: Is the check result normal?

YES : Go to Step 3.

NO : Repair the connector.

STEP 3. Check the wiring harness between BMU connector (terminal No.7, 6, 22, 8) and main drive lithium-ion battery electric current sensor connector (terminal No.1, 2, 3, 4)

Check power supply or signal line for open or short circuit.

Q: Is the check result normal?

YES : Go to Step 4.

NO : Repair the wiring harness.

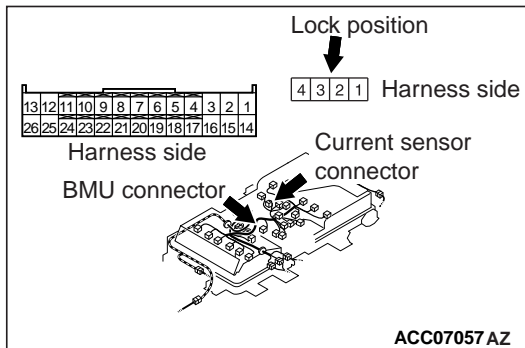

STEP 4. Perform resistance measurement at BMU connector

- Disconnect connector, and measure at BMU side.
- Resistance between terminal No.3 and No.21, No.22.

OK: Continuity (2 Ω or less)

Q: Is the check result normal?

YES : Go to Step 5.

NO : Replace the BMU (Refer to [P.54D-188](#)). Then go to Step 5 .

STEP 5. Check the current sensor in main drive lithium-ion battery

- (1) Removal the current sensor in main drive lithium-ion battery (Refer to [P.54D-207](#)).
- (2) Check the current sensor in main drive lithium-ion battery (Refer to [P.54D-218](#)).

Q: Is the check result normal?

YES : Go to Step 6.

NO : Replace the current sensor in main drive lithium-ion battery (Refer to [P.54D-207](#)).

STEP 6. Use scan tool MB991958 to confirm a diagnostic trouble code.

Q: Is the diagnostic trouble code set?

YES : Replace the BMU (Refer to [P.54D-188](#)).

NO : Intermittent malfunction (Refer to GROUP 00 – How to Use Troubleshooting/Inspection Service Points, How to Cope with Intermittent Malfunctions).

DTC P1A42 BATT. Current SNS. Power Circuit

TROUBLE JUDGMENT

Check Condition

- The electric motor switch is ON position or while the main drive lithium-ion battery is charged.

Judgment Criterion

- The power supply voltage of the main drive lithium-ion battery current sensor is more than 5.3 volts.

or

- The power supply voltage of the main drive lithium-ion battery current sensor is less than 4.7 volts.

FAIL-SAFE AND BACKUP FUNCTION

- Turn off the balancer drive.

PROBABLE CAUSES

- The main drive lithium-ion battery current sensor is failed.
- Open circuits of main drive lithium-ion battery current sensor circuit, short circuits to ground or damage; poor contact of connector.
- The BMU is failed.

DIAGNOSIS

STEP 1. Connector check: BMU connector and main drive lithium-ion battery electric current sensor connector

Removal the main drive lithium-ion battery cover (Refer to [P.54D-194](#)).

Q: Is the check result normal?

YES : Go to Step 2.

NO : Repair the connector.

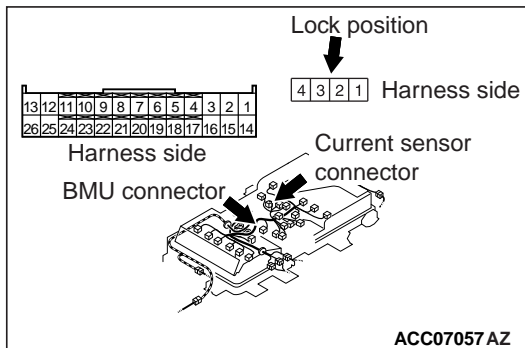

STEP 2. Check the wiring harness between BMU connector (terminal No.6) and main drive lithium-ion battery electric current sensor connector (terminal No.2)

Check power supply or signal line for open or short circuit.

Q: Is the check result normal?

YES : Go to Step 3.

NO : Repair the wiring harness.

STEP 3. Check the current sensor in main drive lithium-ion battery

(1) Removal the current sensor in main drive lithium-ion battery (Refer to [P.54D-207](#)).

(2) Check the current sensor in main drive lithium-ion battery (Refer to [P.54D-218](#)).

Q: Is the check result normal?

YES : Go to Step 4.

NO : Replace the current sensor in main drive lithium-ion battery (Refer to [P.54D-207](#)).

STEP 4. Scan tool MB991958 diagnostic trouble code.

Q: Is the diagnostic trouble code set?

YES : Replace the BMU (Refer to [P.54D-188](#)).

NO : Intermittent malfunction (Refer to GROUP 00 – How to Use Troubleshooting/Inspection Service Points, How to Cope with Intermittent Malfunctions).

DTC P1A43 BATT. Current SNS. Detect Circuit

TROUBLE JUDGMENT

Check Conditions

- 3 seconds elapse after the electric motor switch is turned ON, or 3 seconds elapse after the main drive lithium-ion battery starts to be charged.
- The control value of the main drive lithium-ion battery current sensor (high) is more than -20 amperes and less than 20 amperes.
- Either one of the following diagnostic trouble codes is not set.
 - a. P1A42: BATT. circuit SNS. power circuit
 - b. P1A40: Battery current sensor ($\pm 350A$)
 - c. P1A41: Battery current sensor ($\pm 30A$)

Judgment Criterion

- The difference is more than 10 amperes between the control value of the Main Drive Lithium-ion Battery current sensor (high) and the control value of the Main Drive Lithium-ion Battery current sensor (low).

Check Conditions

- 3 seconds elapse after the electric motor switch is turned ON, or 3 seconds elapse after the main drive lithium-ion battery starts to be charged.
- Either one of the following diagnostic trouble codes is not set.
 - a. P1A42: BATT. circuit SNS. power circuit
 - b. P1A40: Battery current sensor ($\pm 350A$)
 - c. P1A41: Battery current sensor ($\pm 30A$)

Judgment Criterion

- The output voltage of the main drive lithium-ion battery current sensor (high) is less than 0.3 volt.

or

- The output voltage of the main drive lithium-ion battery current sensor (high) is more than 4.7 volts.

FAIL-SAFE AND BACKUP FUNCTION

- Turn off the balancer drive.

PROBABLE CAUSES

- The main drive lithium-ion battery current sensor is failed.
- Damage of main drive lithium-ion battery current sensor circuit; poor contact of connector.
- The BMU is failed.

DIAGNOSIS

STEP 1. Scan tool MB991958 data list

- Refer to Data List Reference Table.
 - a. Item 12: battery current
 - b. Item 13: BAT. current HI control value
 - c. Item 14: BAT. current LO control value

Q: Are all check results normal?

YES : Intermittent malfunction (Refer to GROUP 00 – How to Use Troubleshooting/Inspection Service Points, How to Cope with Intermittent Malfunctions).

NO : Go to Step 2.

STEP 2. Connector check: BMU connector and main drive lithium-ion battery electric current sensor connector

Removal of the main drive lithium-ion battery cover (Refer to [P.54D-194](#)).

Q: Is the check result normal?

YES : Go to Step 3.

NO : Repair the connector.

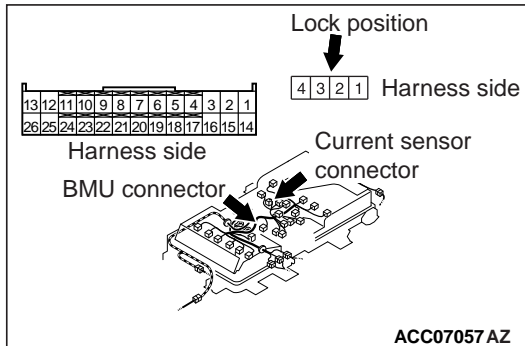

STEP 3. Check the wiring harness between BMU connector (terminal No.7, 6, 22, 8) and main drive lithium-ion battery electric current sensor connector (terminal No.1, 2, 3, 4)
 Check power supply or signal line for open or short circuit.

Q: Is the check result normal?

YES : Go to Step 4.

NO : Repair the wiring harness.

STEP 4. Perform resistance measurement at BMU connector

- Disconnect connector, and measure at BMU side.
- Resistance between terminal No.3 and No.21.

OK: Continuity (2 Ω or less)

Q: Is the check result normal?

YES : Go to Step 5.

NO : Replace the BMU (Refer to [P.54D-188](#)). Then go to Step 5 .

STEP 5. Check the current sensor in main drive lithium-ion battery

- (1) Removal the current sensor in main drive lithium-ion battery (Refer to [P.54D-207](#)).
- (2) Check the current sensor in main drive lithium-ion battery (Refer to [P.54D-218](#)).

Q: Is the check result normal?

YES : Go to Step 6.

NO : Replace the current sensor in main drive lithium-ion battery (Refer to [P.54D-207](#)).

STEP 6. Scan tool MB991958 diagnostic trouble code.

Q: Is the diagnostic trouble code set?

YES : Replace the BMU (Refer to [P.54D-188](#)).

NO : Intermittent malfunction (Refer to GROUP 00 – How to Use Troubleshooting/Inspection Service Points, How to Cope with Intermittent Malfunctions).

TROUBLE JUDGMENT**Check Conditions**

- After the electric motor switch is turned ON, or after the main drive lithium-ion battery starts to be charged.
- Not during the quick charge.

Judgment Criterion

- Ground fault is detected.

FAIL-SAFE AND BACKUP FUNCTION

- Not available

PROBABLE CAUSES

- Ground fault of high voltage system component
- The BMU is failed.

DIAGNOSIS** DANGER**

- *When high voltage system components are serviced, be sure to remove service plug to shut down high voltage (Refer to GROUP 00 – Precautions before service, Precautions on how to use the high-voltage vehicle).*
- *When removing service plug, wear the specified protective equipment.*

STEP 1. Use scan tool MB991958 to confirm a diagnostic trouble code.

- Electric motor switch: 20 seconds elapse after ON
- Select lever position: P range

Q: Is the diagnostic trouble code set?

YES : If the diagnostic trouble code is set during the electric motor switch ON, the ground fault could occur inside the main drive lithium-ion battery. Then go to Step 2.

NO : Go to Step 8.

STEP 2. Check the service plug for the insulation resistance

⚠ DANGER

- **Check the high-voltage circuit while reading carefully the precautions on handling a high-voltage vehicle.**
- **Be sure to wear the specified protective equipment when pulling the service plug.**

⚠ CAUTION

When the insulation resistance is measured, set the range of the special tool electric insulation tester (MB992355) to 500 V. When the insulation resistance is measured at the range more than 500 V, the component may be damaged.

- Use the special tool electric insulation tester (MB992355) to set the range to 500 V.
- Insulation resistance between service plug forward terminal and ground.

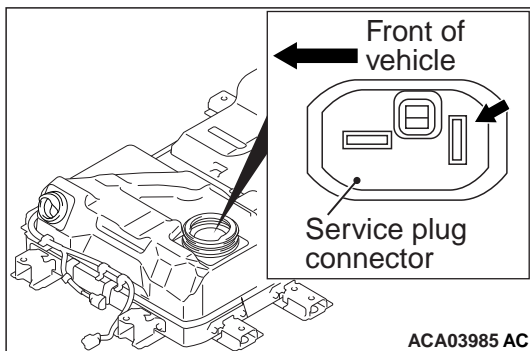
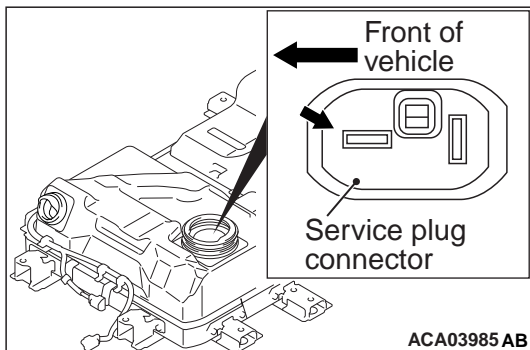

- Insulation resistance between service plug backward terminal and ground.

OK: 10 MΩ or more

Q: Is the check result normal?

YES : Go to Step 7.

NO : Go to Step 3.

STEP 3. Check the service plug for the insulation resistance

⚠ DANGER

- **Check the high-voltage circuit while reading carefully the precautions on handling a high-voltage vehicle.**
- **Be sure to wear the specified protective equipment when pulling the service plug.**

⚠ CAUTION

When the insulation resistance is measured, set the range of the special tool electric insulation tester (MB992355) to 500 V. When the insulation resistance is measured at the range more than 500 V, the component may be damaged.

- Use the special tool electric insulation tester (MB992355) to set the range to 500 V.
- Removal the each contactor (Refer to [P.54D-189](#)).
- Insulation resistance between service plug forward terminal and main drive lithium-ion battery mounting.

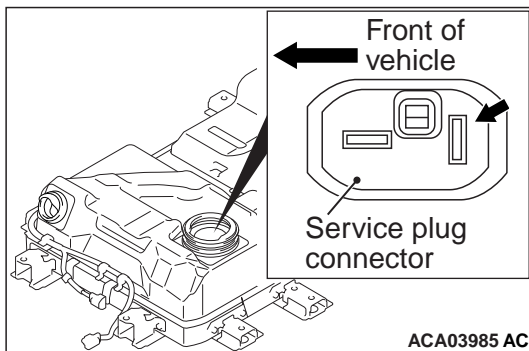
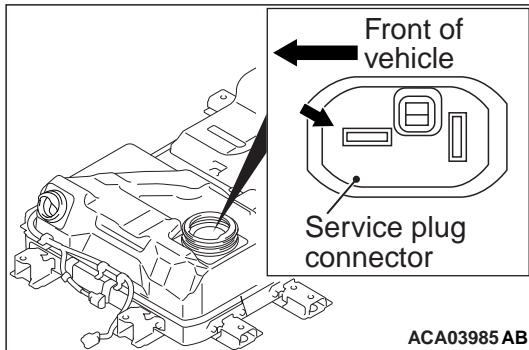

- Insulation resistance between service plug backward terminal and main drive lithium-ion battery mounting.

OK: 10 MΩ or more

Q: Is the check result normal?

YES : Check the each contactor (Refer to [P.54D-216](#)).

NO : Go to Step 4.

STEP 4. Check the service plug for the insulation resistance

⚠ DANGER

- **Check the high-voltage circuit while reading carefully the precautions on handling a high-voltage vehicle.**
- **Be sure to wear the specified protective equipment when pulling the service plug.**

⚠ CAUTION

When the insulation resistance is measured, set the range of the special tool electric insulation tester (MB992355) to 500 V. When the insulation resistance is measured at the range more than 500 V, the component may be damaged.

- Use the special tool electric insulation tester (MB992355) to set the range to 500 V.
- Removal the resistor (Refer to P.54D-189).
- Insulation resistance between service plug forward terminal and main drive lithium-ion battery mounting.

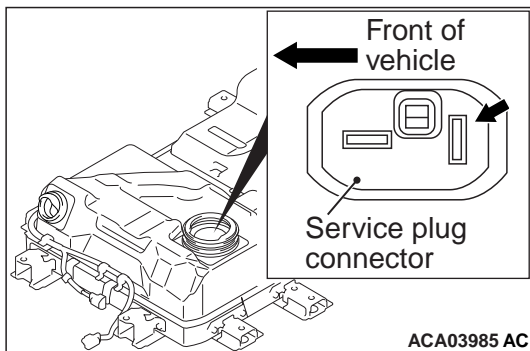
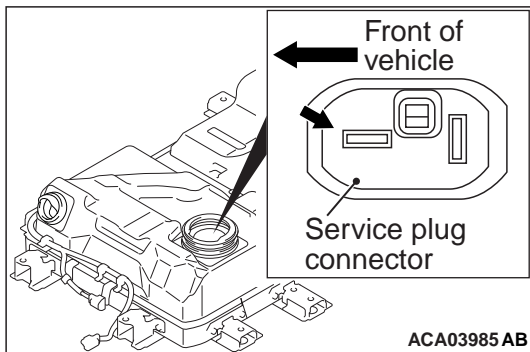

- Insulation resistance between service plug backward terminal and main drive lithium-ion battery mounting.

OK: 10 MΩ or more

Q: Is the check result normal?

YES : Check the resistor (Refer to P.54D-218).

NO : Go to Step 5.

STEP 5. Check the service plug for the insulation resistance**⚠ DANGER**

- **Check the high-voltage circuit while reading carefully the precautions on handling a high-voltage vehicle.**
- **Be sure to wear the specified protective equipment when pulling the service plug.**

⚠ CAUTION

When the insulation resistance is measured, set the range of the special tool electric insulation tester (MB992355) to 500 V. When the insulation resistance is measured at the range more than 500 V, the component may be damaged.

- Use the special tool electric insulation tester (MB992355) to set the range to 500 V.
- Remove cable between the BMU and bus bar (Refer to [P.54D-189](#)).
- Insulation resistance between service plug forward terminal and main drive lithium-ion battery mounting.

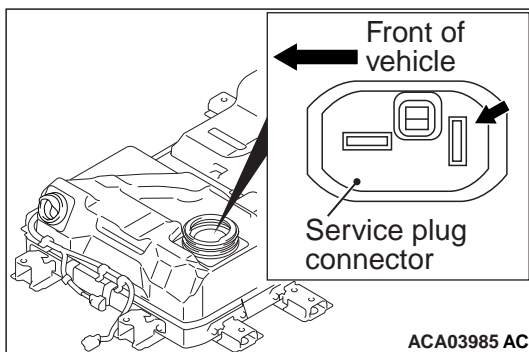
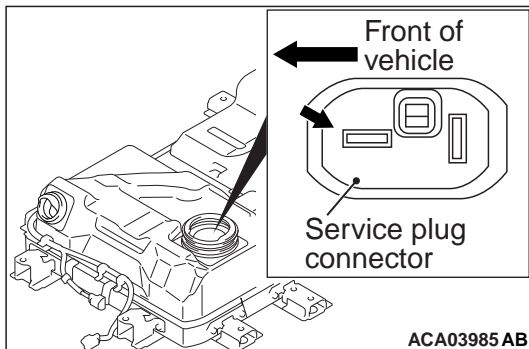

- Insulation resistance between service plug backward terminal and main drive lithium-ion battery mounting.

OK: 10 MΩ or more

Q: Is the check result normal?

YES : Replace cable between the BMU and bus bar (Refer to [P.54D-197](#)) or BMU (Refer to [P.54D-188](#)).

NO : Go to Step 6.

STEP 6. Check the service plug for the insulation resistance

⚠ DANGER

- **Check the high-voltage circuit while reading carefully the precautions on handling a high-voltage vehicle.**
- **Be sure to wear the specified protective equipment when pulling the service plug.**

⚠ CAUTION

When the insulation resistance is measured, set the range of the special tool electric insulation tester (MB992355) to 500 V. When the insulation resistance is measured at the range more than 500 V, the component may be damaged.

- Use the special tool electric insulation tester (MB992355) to set the range to 500 V.
- Remove the bus bar (Refer to P.54D-189).
- Insulation resistance between service plug forward terminal and main drive lithium-ion battery mounting.

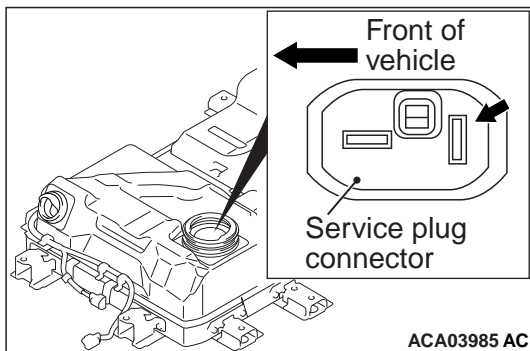
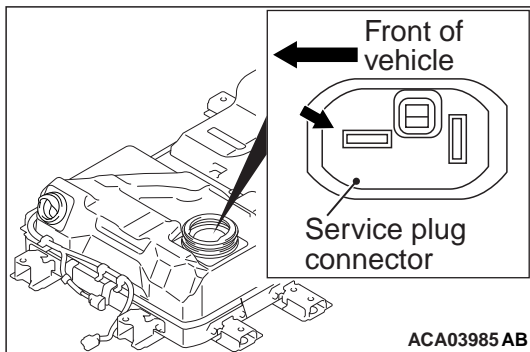

- Insulation resistance between service plug backward terminal and main drive lithium-ion battery mounting.

OK: 10 MΩ or more

Q: Is the check result normal?

YES : heck to tighten the bus bar in the main drive lithium-ion battery (Refer to P.54D-197).

NO : Go to Step 7.

STEP 7. Use scan tool MB991958 to check diagnostic trouble code related to the other systems

Check if the diagnostic trouble code is stored in the BMU.

Q: Is the diagnostic trouble code stored?

YES : Carry out troubleshooting for the diagnostic trouble code.

NO : Go to Step 8.

STEP 8. Use scan tool MB991958 to confirm a diagnostic trouble code.

- Electric motor switch: READY
- Select lever position: P range
- A/C switch: OFF

Q: Is the diagnostic trouble code set?

YES : Go to Step 22.

NO : Go to Step 9.

STEP 9. Use scan tool MB991958 to confirm a diagnostic trouble code.

- Electric motor switch: READY
- Select lever position: D range

Q: Is the diagnostic trouble code set?

YES : Go to Step 10.

NO : Go to Step 18.

STEP 10. Connector check: G-07 inverter (U terminal) connector, G-08 inverter (V terminal) connector, G-09 inverter (W terminal) connector

 **DANGER**

- *When high voltage system components are serviced, be sure to remove service plug to shut down high voltage (Refer to GROUP 00 – Precautions before service, Precautions on how to use the high-voltage vehicle).*
- *When removing service plug, wear the specified protective equipment.*

Q: Is the check result normal?

YES : Go to Step 11.

NO : Repair the terminals.

STEP 11. Check the G-07 inverter (U terminal) connector, G-08 inverter (V terminal) connector and G-09 inverter (W terminal) connector for the insulation resistance.

⚠ CAUTION

When the insulation resistance is measured, set the range of the special tool electric insulation tester (MB992355) to 500 volts. When the insulation resistance is measured at the range more than 500 volts, the component may be damaged.

- Disconnect connector, and measure at harness side.
- Use the special tool electric insulation tester (MB992355) to set the range to 500 volts.
- Insulation resistance between terminal No. 1 and body ground.

OK: 10 MΩ or more

Q: Is the check result normal?

YES : The inverter could have ground fault. Check the insulation resistance of inverter.

NO : Go to Step 12.

STEP 12. Connector check: G-16 motor (electric motor unit: U terminal) connector

Q: Is the check result normal?

YES : Go to Step 13.

NO : Repair the terminal.

STEP 13. Check the G-07 inverter (U terminal) connector for the insulation resistance.

⚠ CAUTION

When the insulation resistance is measured, set the range of the special tool electric insulation tester (MB992355) to 500 volts. When the insulation resistance is measured at the range more than 500 volts, the component may be damaged.

- Disconnect connector, and measure at harness side.
- Disconnect G-16 motor (electric motor unit: U terminal) connector.
- Use the special tool electric insulation tester (MB992355) to set the range to 500 volts.
- Insulation resistance between terminal No. 1 and case shield ground.

OK: 10 MΩ or more

Q: Is the check result normal?

YES : Go to Step 14.

NO : Replace the motor (electric motor unit) cable.

STEP 14. Connector check: G-15 motor (electric motor unit: V terminal) connector

Q: Is the check result normal?

YES : Go to Step 15.

NO : Repair the terminal.

STEP 15. Check the G-08 inverter (V terminal) connector for the insulation resistance.

⚠ CAUTION

When the insulation resistance is measured, set the range of the special tool electric insulation tester (MB992355) to 500 volts. When the insulation resistance is measured at the range more than 500 volts, the component may be damaged.

- Disconnect connector, and measure at harness side.
- Disconnect G-15 motor (electric motor unit: V terminal) connector.
- Use the special tool electric insulation tester (MB992355) to set the range to 500 volts.
- Insulation resistance between terminal No. 1 and case shield ground.

OK: 10 M Ω or more

Q: Is the check result normal?

YES : Go to Step 16.

NO : Replace the motor (electric motor unit) cable.

STEP 16. Connector check: G-14 motor (electric motor unit: W terminal) connector

Q: Is the check result normal?

YES : Go to Step 17.

NO : Repair the terminal.

STEP 17. Check the G-09 inverter (W terminal) connector for the insulation resistance.

⚠ CAUTION

When the insulation resistance is measured, set the range of the special tool electric insulation tester (MB992355) to 500 volts. When the insulation resistance is measured at the range more than 500 volts, the component may be damaged.

- Disconnect connector, and measure at harness side.
- Disconnect G-14 motor (electric motor unit: W terminal) connector.
- Use the special tool electric insulation tester (MB992355) to set the range to 500 volts.
- Insulation resistance between terminal No. 1 and case shield ground.

OK: 10 MΩ or more

Q: Is the check result normal?

YES : Replace the motor (electric motor unit).

NO : Replace the motor (electric motor unit) cable.

STEP 18. Use scan tool MB991958 to confirm a diagnostic trouble code.

- Electric motor switch: READY
- A/C set temperature: minimum temperature
- A/C switch: ON
- MAX switch: ON

Q: Is the diagnostic trouble code set?

YES : Go to Step 19.

NO : Go to Step 20.

STEP 19. After replacing the A/C refrigerant and the compressor oil, check the diagnosis trouble code again.

- Electric motor switch: READY
- A/C set temperature: minimum temperature
- A/C switch: ON
- MAX switch: ON

Q: Is the diagnostic trouble code set?

YES : Replace the A/C compressor (Refer to GROUP 55 – Compressor Assembly).

NO : Check end.

STEP 20. Use scan tool MB991958 to confirm a diagnostic trouble code.

- Electric motor switch: READY
- A/C set temperature: maximum temperature
- MAX switch: ON

Q: Is the diagnostic trouble code set?

YES : Replace the electric hot water heater (Refer to GROUP 55 – Heater).

NO : Go to Step 15.

STEP 21. Use scan tool MB991958 to confirm a diagnostic trouble code.

NOTE: Turn the electric motor switch ON position and connect the charging cable. Then turning the electric motor switch LOCK (OFF) position can check the monitor during the regular charging.

- Electric motor switch: "LOCK" (OFF)
- During the regular charging

Q: Is the diagnostic trouble code set?

YES : Replace the on board charger/DC-DC converter.

NO : Intermittent malfunction (Refer to GROUP 00 – How to Use Troubleshooting/Inspection Service Points – How to Cope with Intermittent Malfunctions).

STEP 22. Check the G-05 inverter (– terminal) connector or the G-06 inverter (+ terminal) connector for the insulation resistance.

 DANGER

- ***When high voltage system components are serviced, be sure to remove service plug to shut down high voltage (Refer to GROUP 00 – Precautions before service, Precautions on how to use the high-voltage vehicle).***
- ***When removing service plug, wear the specified protective equipment.***

 CAUTION

When the insulation resistance is measured, set the range of the special tool electric insulation tester (MB992355) to 500 volts. When the insulation resistance is measured at the range more than 500 volts, the component may be damaged.

- Measure the insulation resistance with the connector connected.
- Use the special tool electric insulation tester (MB992355) to set the range to 500 volts.
- Insulation resistance between terminal No. 1 and body ground.

OK: 10 MΩ or more

Q: Is the check result normal?

YES : Check on main drive lithium-ion battery ground fault detector circuit (Refer to DTC P1A46 Leak sensor detection circuit [P.54D-203](#)).

NO : Go to Step 23.

STEP 23. Check the G-05 inverter (– terminal) connector or the G-06 inverter (+ terminal) connector for the insulation resistance.

⚠ CAUTION

When the insulation resistance is measured, set the range of the special tool electric insulation tester (MB992355) to 500 volts. When the insulation resistance is measured at the range more than 500 volts, the component may be damaged.

- Measure the insulation resistance with the connector connected.
- Use the special tool electric insulation tester (MB992355) to set the range to 500 volts.
- Insulation resistance between terminal No. 1 and body ground.

Q: When the G-20 A/C compressor connector is disconnected, does the insulation resistance change by the value more than 10 MΩ?

YES : The A/C compressor could have ground fault. Check the insulation resistance of A/C compressor.

NO : Go to Step 24.

STEP 24. Check the G-05 inverter (– terminal) connector or the G-06 inverter (+ terminal) connector for the insulation resistance.

⚠ CAUTION

When the insulation resistance is measured, set the range of the special tool electric insulation tester (MB992355) to 500 volts. When the insulation resistance is measured at the range more than 500 volts, the component may be damaged.

- Measure the insulation resistance with the connector connected.
- Use the special tool electric insulation tester (MB992355) to set the range to 500 volts.
- Insulation resistance between terminal No. 1 and body ground.

Q: When the G-21 heater connector is disconnected, does the insulation resistance change by the value more than 10 MΩ?

YES : The heater could have ground fault. Check the insulation resistance of heater.

NO : Go to Step 25.

STEP 25. Check the G-05 inverter (– terminal) connector or G-06 inverter (+ terminal) connector for the insulation resistance.

⚠ CAUTION

When the insulation resistance is measured, set the range of the special tool electric insulation tester (MB992355) to 500 volts. When the insulation resistance is measured at the range more than 500 volts, the component may be damaged.

- Measure the insulation resistance with the connector connected.
- Use the special tool electric insulation tester (MB992355) to set the range to 500 volts.
- Insulation resistance between terminal No. 1 and body ground.

Q: When the G-05 inverter (– terminal) connector and the G-06 inverter (+ terminal) connector are disconnected, does the insulation resistance change by the value more than 10 M Ω ?

YES : Go to Step 26.

NO : Go to Step 29.

STEP 26. Connector check: G-18 main drive lithium-ion battery connector, G-19 main drive lithium-ion battery connector

Q: Is the check result normal?

YES : Go to Step 27.

NO : Repair the terminals.

STEP 27. Check the G-05 inverter (– terminal) connector for the insulation resistance.

⚠ CAUTION

When the insulation resistance is measured, set the range of the special tool electric insulation tester (MB992355) to 500 volts. When the insulation resistance is measured at the range more than 500 volts, the component may be damaged.

- Disconnect connector, and measure at harness side.
- Disconnect G-18 main drive lithium-ion battery connector.
- Use the special tool electric insulation tester (MB992355) to set the range to 500 volts.
- Insulation resistance between terminal No. 1 and body ground.

OK: 10 M Ω or more

Q: Is the check result normal?

YES : Go to Step 28.

NO : Replace the main drive lithium-ion battery cable.

STEP 28. Check the G-06 inverter (+ terminal) connector for the insulation resistance.

⚠ CAUTION

When the insulation resistance is measured, set the range of the special tool electric insulation tester (MB992355) to 500 volts. When the insulation resistance is measured at the range more than 500 volts, the component may be damaged.

- Disconnect connector, and measure at harness side.
- Disconnect G-19 main drive lithium-ion battery connector.
- Use the special tool electric insulation tester (MB992355) to set the range to 500 volts.
- Insulation resistance between terminal No. 1 and body ground.

OK: 10 MΩ or more

Q: Is the check result normal?

YES : Go to Step 30.

NO : Replace the main drive lithium-ion battery cable.

STEP 29. Check the G-05 inverter (– terminal) connector or the G-06 inverter (+ terminal) connector for the insulation resistance.

⚠ CAUTION

When the insulation resistance is measured, set the range of the special tool electric insulation tester (MB992355) to 500 volts. When the insulation resistance is measured at the range more than 500 volts, the component may be damaged.

- Measure the insulation resistance with the connector connected.
- Use the special tool electric insulation tester (MB992355) to set the range to 500 volts.
- Insulation resistance between terminal No. 1 and body ground.

Q: When the G-26 inverter and on board charger/DC-DC converter combination connector is disconnected, does the insulation resistance changes by the value more than 10 MΩ?

YES : The on board charger/DC-DC converter could have ground fault. Check the insulation resistance of on board charger/DC-DC converter.

NO : Go to Step 30.

STEP 30. After check for insulation resistance of the inverter, reconfirm the scan tool MB991958 diagnostic trouble code

- Recheck if the diagnostic trouble code is set again after check for insulation resistance of the inverter.

Q: Is the diagnostic trouble code set?

YES : Replace the BMU (Refer to [P.54D-188](#)).

NO : Check end.

DTC P1A46 Leak Sensor Detection Circuit

TROUBLE JUDGMENT**Check Conditions**

- After the electric motor switch is turned ON, or after the main drive lithium-ion battery starts to be charged.
- Not during the quick charge.

Judgment Criterion

- Defective leakage-of-electricity detection circuit.

FAIL-SAFE AND BACKUP FUNCTION

- Not available

PROBABLE CAUSES

- Ground fault of high voltage system component.
- The main drive lithium-ion battery ground fault detector is failed.
- Open circuits of main drive lithium-ion battery ground fault detector circuit, short circuits to ground, short circuits to power supply system or damage; poor contact of connector.
- The BMU is failed.

DIAGNOSIS** DANGER**

- *When high voltage system components are serviced, be sure to remove service plug to shut down high voltage (Refer to GROUP 00 – Precautions before service, Precautions on how to use the high-voltage vehicle).*
- *When removing service plug, wear the specified protective equipment.*

STEP 1. Use scan tool MB991958 to confirm a diagnostic trouble code.

Q: Is the diagnostic trouble code set?

YES : Carry out troubleshooting for DTC P1A44. Then go to Step 2.

NO : Intermittent malfunction (Refer to GROUP 00 – How to Use Troubleshooting/Inspection Service Points, How to Cope with Intermittent Malfunctions).

STEP 2. Use scan tool MB991958 to confirm a diagnostic trouble code

Q: Is the diagnostic trouble code set?

YES : Go to Step 3.

NO : Check end.

STEP 3. Connector check: C-21 main drive lithium-ion battery connector

Q: Is the check result normal?

YES : Go to Step 4.

NO : Repair the connector.

STEP 4. Perform resistance measurement at C-21 main drive lithium-ion battery connector

- Disconnect connector, and measure at vehicle harness side.
- Resistance between terminal No.2 and No.13.

OK: Continuity (2Ω or less)

Q: Is the check result normal?

YES : Go to Step 5.

NO : Repair the wiring harness.

STEP 5. Connector check: BMU connector

Removal the main drive lithium-ion battery cover (Refer to [P.54D-194](#)).

Q: Is the check result normal?

YES : Go to Step 6.

NO : Repair the connector.

STEP 6. Check the wiring harness between BMU connector (terminal No.3, 26) and C-21 main drive lithium-ion battery connector (terminal No.2, 13)

Check signal line for open or short circuit.

Q: Is the check result normal?

YES : Go to Step 7.

NO : Repair the wiring harness.

STEP 7. Check the ground fault detector cable between BMU connector and bus bar

Check line for open or short circuit.

Q: Is the check result normal?

YES : Go to Step 8.

NO : Repair the ground fault detector cable (Refer to [P.54D-197](#)).

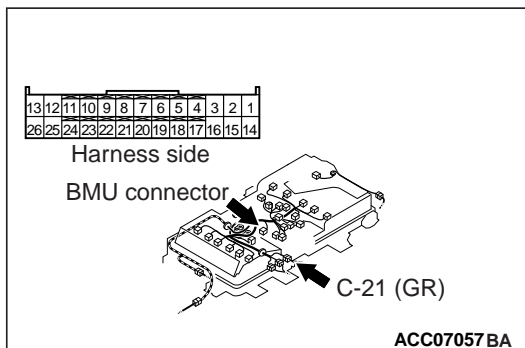

STEP 8. Use scan tool MB991958 to confirm a diagnostic trouble code

Q: Is the diagnostic trouble code set?

YES : Replace the BMU (Refer to [P.54D-188](#)).

NO : Check end.

DTC P1A48 BATT. Cooling Fan Output Circuit

TROUBLE JUDGMENT

Check Conditions

- The electric motor switch is ON position or while the main drive lithium-ion battery is charged.

Judgment Criterion

- The PWM output signal of the main drive lithium-ion battery cooling fan is 100 % (while the fan is stopped) and the PWM output signal status of the main drive lithium-ion battery cooling fan is High (during the rotation).

FAIL-SAFE AND BACKUP FUNCTION

- Not available

PROBABLE CAUSES

- The main drive lithium-ion battery cooling fan is failed.
- Short circuits to power supply system of main drive lithium-ion battery cooling fan circuit; poor contact of connector.
- The BMU is failed.

DIAGNOSIS

STEP 1. Connector check: C-14 main drive lithium-ion battery connector

Q: Is the check result normal?

YES : Go to Step 2.

NO : Repair the connector.

STEP 2. Perform voltage measurement at C-14 main drive lithium-ion battery connector.

- Disconnect the connector and measure the voltage at the female side.
- Electric motor switch: ON
- Voltage between terminal No. 2 and ground.

OK: 0 – 0.1 volt

Q: Is the check result normal?

YES : Go to Step 8.

NO : Go to Step 3.

STEP 3. Connector check: C-21 main drive lithium-ion battery connector

Q: Is the check result normal?

- YES** : Go to Step 4.
- NO** : Repair the connector.

STEP 4. Check harness between C-14 (terminal No.2) main drive lithium-ion battery connector and C-21 (terminal No.7) main drive lithium-ion battery connector

- Check output line for short circuit to power supply.

Q: Is the check result normal?

- YES** : Go to Step 5.
- NO** : Repair the wiring harness.

STEP 5. Connector check: BMU connector

Removal the main drive lithium-ion battery cover (Refer to [P.54D-194](#)).

Q: Is the check result normal?

- YES** : Go to Step 6.
- NO** : Repair the connector.

STEP 6. Check the wiring harness between BMU connector (terminal No.9) and C-21 main drive lithium-ion battery connector (terminal No.7)

- Check output line for short circuit to power supply.

Q: Is the check result normal?

- YES** : Go to Step 7.
- NO** : Repair the wiring harness.

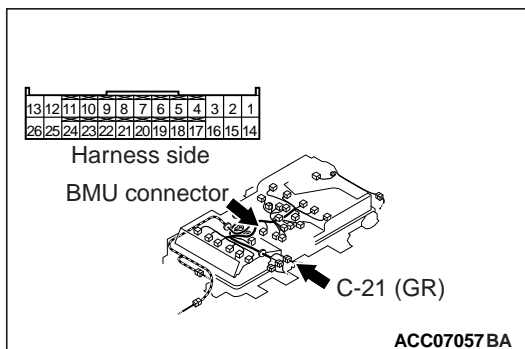

STEP 7. Use scan tool MB991958 to confirm a diagnostic trouble code.

Q: Is the diagnostic trouble code set?

- YES** : Replace the BMU (Refer to [P.54D-188](#)).
- NO** : Intermittent malfunction (Refer to GROUP 00 – How to Use Troubleshooting/Inspection Service Points, How to Cope with Intermittent Malfunctions).

STEP 8. Scan tool MB991958 diagnostic trouble code

Q: Is the diagnostic trouble code stored?

- YES** : Go to Step 9.
- NO** : Intermittent malfunction (Refer to GROUP 00 – How to Use Troubleshooting/Inspection Service Points – How to Cope with Intermittent Malfunctions).

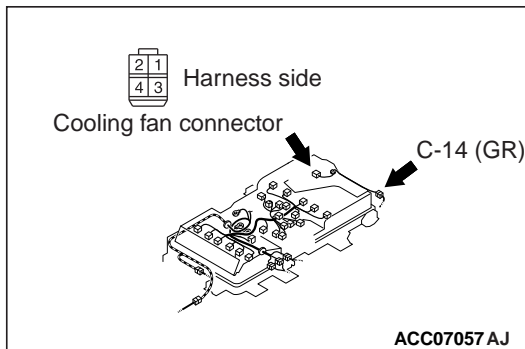

STEP 9. Connector check: C-14 main drive lithium-ion battery fan connector, cooling fan connector

Removal the main drive lithium-ion battery cover (Refer to [P.54D-189](#)).

Q: Is the check result normal?

YES : Go to Step 10.

NO : Repair the damaged connector.

STEP 10. Check the wiring harness between C-14 (terminal No.2) Main Drive Lithium-ion Battery fan connector and cooling fan (terminal No.4) connector

Check power supply line, out signal line and ground line for open circuit.

Q: Is the check result normal?

YES : Replace the cooling fan in main drive lithium-ion battery (Refer to [P.54D-211](#)).

NO : Repair the wiring harness.

DTC P1A6A CMU01 Battery Temperature, P1A6B CMU02 Battery Temperature, P1A6C CMU03 Battery Temperature, P1A6D CMU04 Battery Temperature, P1A6E CMU05 Battery Temperature, P1A6F CMU06 Battery Temperature, P1A70 CMU07 Battery Temperature, P1A71 CMU08 Battery Temperature, P1A72 CMU09 Battery Temperature, P1A73 CMU10 Battery Temperature, P1A74 CMU11 Battery Temperature, P1A75 CMU12 Battery Temperature

TROUBLE JUDGMENT
Check Conditions

- 3 seconds elapse after the electric motor switch is turned ON, or 3 seconds elapse after the main drive lithium-ion battery starts to be charged.
- Either one of the following diagnostic trouble codes is not set.
 - a. P1AA8: Bat-CAN signal time out
 - b. U1082: Bat-CAN bus-off

Judgment Criterion

- The module temperature is more than 60°C (140°F).

FAIL-SAFE AND BACKUP FUNCTION

- Drive the Main Drive Lithium-ion Battery fan for 10 minutes after judging malfunctions.

PROBABLE CAUSES

- The main drive lithium-ion battery cooling is insufficient with the failed air conditioning control system.

- The module (battery cell, CMU and module temperature sensor) in the main drive lithium-ion battery is failed.

DIAGNOSIS

STEP 1. Scan tool MB991958 other system diagnostic trouble code.

Q: Is diagnostic trouble code of A/C control unit set?

YES : Check the A/C control unit. (Refer to GROUP 55 – A/C Diagnosis – DTC Chart <A/C control unit>).

NO : Go to Step 2.

STEP 2. Scan tool MB991958 actuator test

(1) Check the A/C control unit. (Refer to GROUP 55 – Actuator Test Reference Table <A/C control unit>).

- Item No. 02: Battery cooling flap motor

Q: Is the check result normal?

YES : Go to Step 3.

NO : Main drive lithium-ion battery cooling selection damper motor check.

STEP 3. Scan tool MB991958 data list

- Check the data list reference table corresponding to the diagnostic trouble code.

OK: At ambient temperature (atmospheric temperature) or equivalent (when the vehicle driving and the charge are not performed for a long time)

Q: Is the check result normal?

YES : Intermittent malfunction (Refer to GROUP 00 – How to Use Troubleshooting/Inspection Service Points, How to Cope with Intermittent Malfunctions).

NO : Go to Step 4.

STEP 4. Use scan tool MB991958 to confirm a diagnostic trouble code of other systems.

- (1) Select "Reset" on the special function screen of the relevant CMU ID (Refer to GROUP 00 – Precautions Before Service, How to Reset Failure Information in the CMU EEPROM), and then execute it.
- (2) Check the data list corresponding to the relevant CMU ID.
 - Item No. 14: Reference low voltage
 - Item No. 15: Reference high voltage
 - Item No. 16 – No. 21: Temperature sensor (1 – 6) (open)
 - Item No. 22 – No. 27: Temperature sensor (1 – 6) (short)
 - Item No. 44 – No. 49: Temperature sensor (1 – 6) under-flow
 - Item No. 50 – No. 55: Temperature sensor (1 – 6) over-flow
 - Item No. 67: A/D conversion (Reference volt)
 - Item No. 68 – No. 73: A/D conversion (temp. sensor 1 – 6)

Q: Is the check result normal?

- YES** : Intermittent malfunction (Refer to GROUP 00 – How to Use Troubleshooting/Inspection Service Points – How to Cope with Intermittent Malfunctions).
- NO** : Check to tighten the bus bar in the main drive lithium-ion battery or replace the main drive lithium-ion battery assembly.

DTC P1A76 CMU01 Cell Voltage Sensor, P1A77 CMU02 Cell Voltage Sensor, P1A78 CMU03 Cell Voltage Sensor, P1A79 CMU04 Cell Voltage Sensor, P1A7A CMU05 Cell Voltage Sensor, P1A7B CMU06 Cell Voltage Sensor, P1A7C CMU07 Cell Voltage Sensor, P1A7D CMU08 Cell Voltage Sensor, P1A7E CMU09 Cell Voltage Sensor, P1A7F CMU10 Cell Voltage Sensor, P1A80 CMU11 Cell Voltage Sensor, P1A81 CMU12 Cell Voltage Sensor

TROUBLE JUDGMENT**Check Conditions**

- 3 seconds elapse after the electric motor switch is turned ON, or 3 seconds elapse after the main drive lithium-ion battery starts to be charged.
- Either one of the following diagnostic trouble codes is not set.
 - a. P1AA8: Bat-CAN signal time out
 - b. U1082: Bat-CAN bus-off

Judgment Criterion

- The signal is received from the appropriate module CMU, which shows that one of the battery cell voltage has an invalid value.

FAIL-SAFE AND BACKUP FUNCTION

- If the CMU detecting abnormalities also detects the module temperature sensor abnormalities, drive the main drive lithium-ion battery fan for 10 minutes.

PROBABLE CAUSE

- The module (battery cell, CMU and battery cell voltage sensor) in the main drive lithium-ion battery is failed.
- The BMU is failed.

DIAGNOSIS

STEP 1. Scan tool MB991958 data list

- Check the data list reference table corresponding to the diagnostic trouble code.

OK: Not 2.51 volts (initial value) (electric motor switch: LOCK (OFF) → ON)

Q: Is the check result normal?

YES : Intermittent malfunction (Refer to GROUP 00 – How to Use Troubleshooting/Inspection Service Points, How to Cope with Intermittent Malfunctions).

NO : Go to Step 2.

STEP 2. Scan tool MB991958 data list of others system

(1) Select "Reset" for the relevant CMU ID on the special function screen (Refer to GROUP 00 – Precautions Before Service, How to Reset Failure Information in the CMU EEPROM), and then execute it.

(2) Check the data list on the relevant CMU ID.

- Item No. 1: Module voltage
- Item No. 2: Cell total voltage
- Item No. 3: Voltage diff. (Module – Total cell)
- Item No. 4 – No. 11: Cell (A – H) voltage
- Item No. 12: Cell Monitor IC
- Item No. 13: Voltage sensor
- Item No. 28 – No. 35: Cell (A – H) voltage underflow
- Item No. 36 – No. 43: Cell (A – H) voltage overflow

Q: Is the check result normal?

YES : Go to Step 3.

NO : Replace the main drive lithium-ion battery assembly.

STEP 3. Use scan tool MB991958 to confirm a diagnostic trouble code.

Q: Is the diagnostic trouble code set?

YES : Replace the BMU (Refer to [P.54D-188](#)).

NO : Check end.

DTC P1A82 CMU01 Battery Temperature Sensor, P1A83 CMU02 Battery Temperature Sensor, P1A84 CMU03 Battery Temperature Sensor, P1A85 CMU04 Battery Temperature Sensor, P1A86 CMU05 Battery Temperature Sensor, P1A87 CMU06 Battery Temperature Sensor, P1A88 CMU07 Battery Temperature Sensor, P1A89 CMU08 Battery Temperature Sensor, P1A8A CMU09 Battery Temperature Sensor, P1A8B CMU10 Battery Temperature Sensor, P1A8C CMU11 Battery Temperature Sensor, P1A8D CMU12 Battery Temperature Sensor

TROUBLE JUDGMENT

Check Conditions

- 3 seconds elapse after the electric motor switch is turned ON, or 3 seconds elapse after the main drive lithium-ion battery starts to be charged.
- Either one of the following diagnostic trouble codes is not set.
 - a. P1AA8: Bat-CAN signal time out
 - b. U1082: Bat-CAN bus-off

Judgment Criterion

- The signal is received from the appropriate module CMU, which shows that one of the module temperatures has an invalid value.

FAIL-SAFE AND BACKUP FUNCTION

- If the CMU detecting abnormalities also detects the battery cell voltage sensor abnormalities, drive the main drive lithium-ion battery fan for 10 minutes.

PROBABLE CAUSES

- The module (battery cell, CMU and module temperature sensor) in the main drive lithium-ion battery is failed.
- The BMU is failed.

DIAGNOSIS

STEP 1. Scan tool MB991958 data list

- Check the data list reference table corresponding to the diagnostic trouble code.

NOTE: To precisely judge the diagnose, do not perform the diagnosis at the temperature of 35°C (95°F) around the main drive lithium-ion battery.

OK: Not 35°C (95°F) (initial value) (electric motor switch: LOCK (OFF) → ON)

Q: Is the check result normal?

YES : Intermittent malfunction (Refer to GROUP 00 – How to Use Troubleshooting/Inspection Service Points, How to Cope with Intermittent Malfunctions).

NO : Go to Step 2.

STEP 2. Scan tool MB991958 data list of others system

- (1) Select "Reset" for the relevant CMU ID on the special function screen (Refer to GROUP 00 – Precautions Before Service, How to Reset Failure Information in the CMU EEPROM), and then execute it.
- (2) Check the data list on the relevant CMU ID.
 - Item No. 14: Reference low voltage
 - Item No. 15: Reference high voltage
 - Item No. 16 – No. 21: Temperature sensor (1 – 6) (open)
 - Item No. 22 – No. 27: Temperature sensor (1 – 6) (short)
 - Item No. 44 – No. 49: Temperature sensor (1 – 6) under-flow
 - Item No. 50 – No. 55: Temperature sensor (1 – 6) over-flow
 - Item No. 67: A/D conversion (Reference volt)

Q: Is the check result normal?

YES : Go to Step 3.

NO : Replace the main drive lithium-ion battery assembly.

STEP 3. Use scan tool MB991958 to confirm a diagnostic trouble code.

Q: Is the diagnostic trouble code set?

YES : Replace the BMU (Refer to [P.54D-188](#)).

NO : Check end.

DTC P1A8E CMU01 Battery Balancing Unit, P1A8F CMU02 Battery Balancing Unit, P1A90 CMU03 Battery Balancing Unit, P1A91 CMU04 Battery Balancing Unit, P1A92 CMU05 Battery Balancing Unit, P1A93 CMU06 Battery Balancing Unit, P1A94 CMU07 Battery Balancing Unit, P1A95 CMU08 Battery Balancing Unit, P1A96 CMU09 Battery Balancing Unit, P1A97 CMU10 Battery Balancing Unit, P1A98 CMU11 Battery Balancing Unit, P1A99 CMU12 Battery Balancing Unit

TROUBLE JUDGMENT

Check Conditions

- 3 seconds elapse after the electric motor switch is turned ON, or 3 seconds elapse after the main drive lithium-ion battery starts to be charged.
- Balancer allowed to be driven is OFF.
- Either one of the following diagnostic trouble codes is not set.
 - a. P1AA8: Bat-CAN signal time out
 - b. U1082: Bat-CAN bus-off

Judgment Criterion

- The signal is received from the appropriate module CMU, which shows that one of the balancer driving conditions is turned ON.

FAIL-SAFE AND BACKUP FUNCTION

- Not available

PROBABLE CAUSES

- The module (CMU) in the main drive lithium-ion battery is failed.
- The BMU is failed.

DIAGNOSIS

STEP 1. Scan tool MB991958 data list

- Check the data list reference table corresponding to the diagnostic trouble code.

OK: OFF (electric motor switch: ON)

Q: Is the check result normal?

YES : Intermittent malfunction (Refer to GROUP 00 – How to Use Troubleshooting/Inspection Service Points, How to Cope with Intermittent Malfunctions).

NO : Go to Step 2.

STEP 2. Scan tool MB991958 data list of others system

- (1) Select "Reset" for the relevant CMU ID on the special function screen (Refer to GROUP 00 – Precautions Before Service, How to Reset Failure Information in the CMU EEPROM), and then execute it.
- (2) Check the data list on the relevant CMU ID.
 - Item No. 58: CAN controller

Q: Is the check result normal?

YES : Go to Step 3.

NO : Replace the main drive lithium-ion battery assembly.

STEP 3. Use scan tool MB991958 to confirm a diagnostic trouble code.**Q: Is the diagnostic trouble code set?**

YES : Replace the BMU (Refer to [P.54D-188](#)).

NO : Check end.

DTC P1AA8: Bat-CAN Signal Time Out

TROUBLE JUDGMENT**Check Conditions**

- 3 seconds elapse after the electric motor switch is turned ON, or 3 seconds elapse after the main drive lithium-ion battery starts to be charged.
- None of the following diagnostic trouble codes is set at the same time.
 - a. Code No. U1082: Bat-CAN bus-off

Judgment Criterion

- One of the CMU signals cannot be received through the CAN communication.

FAIL-SAFE AND BACKUP FUNCTION

- Drive the main drive lithium-ion battery fan for 10 minutes after judging malfunctions.

PROBABLE CAUSES

- The Local CAN (for main drive lithium-ion battery) bus is failed.
- The BMU is failed.

DIAGNOSIS

STEP 1. Use scan tool MB991958 to confirm a diagnostic trouble code.

Q: Is the diagnostic trouble code set?

YES : Go to Step 2.

NO : Intermittent malfunction (Refer to GROUP 00 – How to Use Troubleshooting/Inspection Service Points, How to Cope with Intermittent Malfunctions).

STEP 2. Check CMU12 from CMU01

Check the CMU, which has timed out.

Q: Have all the CMUs been timed out?

YES : Go to Step 8.

NO : Check the CMU, which has timed out. Then go to Step 3.

STEP 3. Connector check: C-22, C-26 main drive lithium-ion battery connector, CMU12 from CMU01 connector, resistor (local CAN terminating) connector

Removal the main drive lithium-ion battery cover (Refer to [P.54D-194](#)).

Q: Is the check result normal?

YES : Go to Step 4.

NO : Repair the damaged connector.

STEP 4. Check the wiring harness between C-22 (terminal No. 4) main drive lithium-ion battery connector and CMU12 from CMU01 (each terminal No. 1) connector

NOTE:

- Before checking harness, check intermediate connector (1) (terminal No. 4, No. 11 from No. 6, No. 22 from No. 15) of out signal line, and repair if necessary.

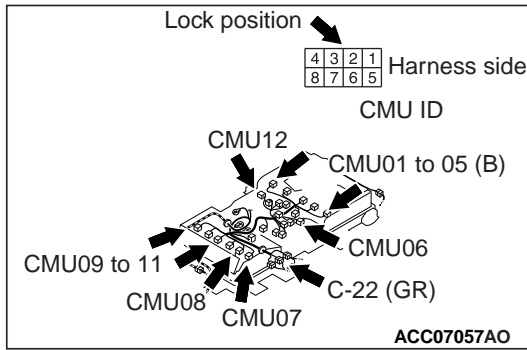

Check power supply line for open circuit.

Q: Is the check result normal?

YES : Go to Step 5.

NO : Repair the wiring harness.

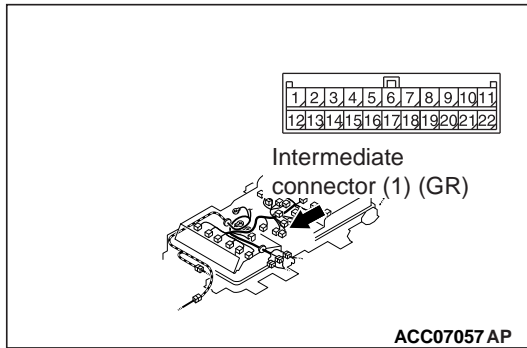

STEP 5. Check the wiring harness between C-26 (terminal No. 5) main drive lithium-ion battery connector and CMU12 from CMU01 (terminal No. 8) connector, resistor (local CAN terminating) (terminal No. 1) connector

NOTE:

- Before checking harness, check intermediate connector (CAN1) (terminal No. 11 from No. 3), intermediate connector (CAN2) (terminal No. 9 from No. 3) of out signal line, and repair if necessary.

Check signal line (CANH) for open circuit.

Q: Is the check result normal?

YES : Go to Step 6.

NO : Repair the wiring harness.

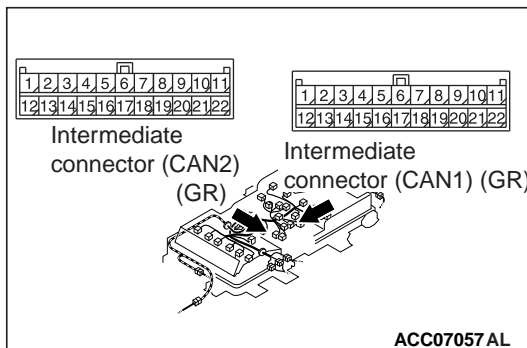
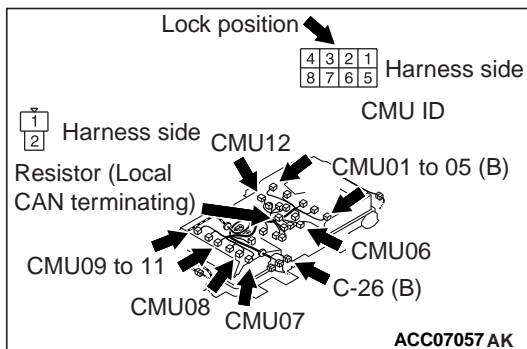

STEP 6. Check the wiring harness between C-26 (terminal No. 10) main drive lithium-ion battery connector and CMU12 from CMU01 (terminal No. 4) connector, resistor (local CAN terminating) (terminal No. 2) connector

NOTE:

- Before checking harness, check intermediate connector (CAN1) terminal No. 22 from No. 14, intermediate connector (CAN2) terminal No. 20 from No. 14 of out signal line, and repair if necessary.

Check signal line (CANL) for open circuit.

Q: Is the check result normal?

YES : Go to Step 7.

NO : Repair the wiring harness.

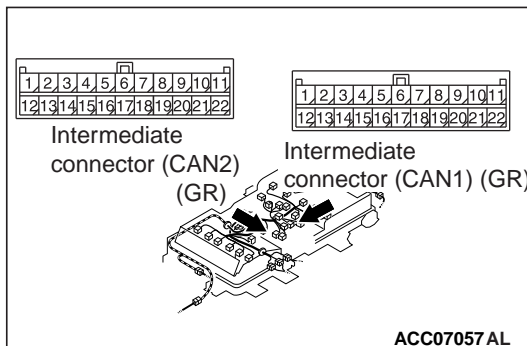
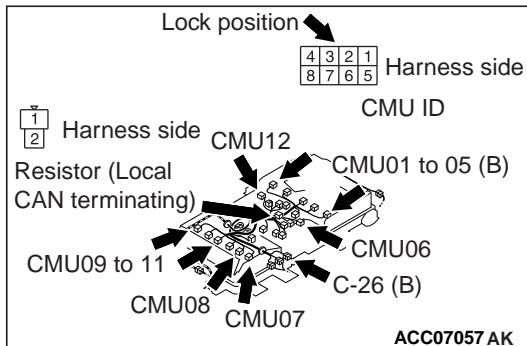

STEP 7. Use scan tool MB991958 to confirm a diagnostic trouble code.

Q: Is the diagnostic trouble code set?

YES : Replace the main drive lithium-ion battery.

NO : Intermittent malfunction (Refer to GROUP 00 – How to Use Troubleshooting/Inspection Service Points, How to Cope with Intermittent Malfunctions).

STEP 8. Check the local CAN (for main drive lithium-ion battery) terminating resistance itself

- (1) Removal the local CAN terminating resistor in main drive lithium-ion battery (Refer to P.54D-189).
- (2) Check the local CAN terminating resistor in main drive lithium-ion battery (Refer to P.54D-217).

Q: Is the check result normal?

YES : Go to Step 13.

NO : Go to Step 9.

STEP 9. Connector check: C-26 main drive lithium-ion battery connector, CMU12 from CMU01 connector, BMU connector, resistor (local CAN terminating) connector
 Removal the main drive lithium-ion battery cover (Refer to P.54D-194).

Q: Is the check result normal?

YES : Go to Step 10.

NO : Repair the damaged connector.

STEP 10. Check the wiring harness between C-26 (terminal No. 5) main drive lithium-ion battery connector and CMU12 from CMU01 (terminal No. 8) connector, BMU (terminal No.24) connector, resistor (local CAN terminating) (terminal No. 1) connector

NOTE:

- Before checking harness, check intermediate connector (CAN1) (terminal No. 11 from No. 3), intermediate connector (CAN2) (terminal No. 9 from No. 2) of out signal line, and repair if necessary.

Check signal line (CANH) for open circuit.

Q: Is the check result normal?

YES : Go to Step 11.

NO : Repair the wiring harness.

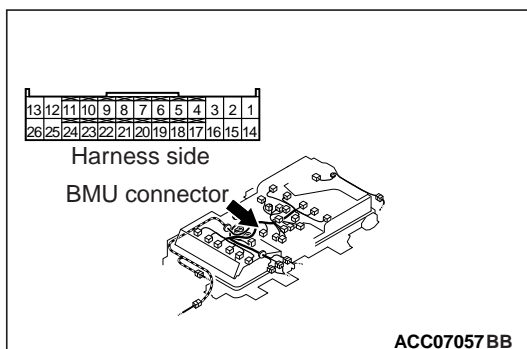
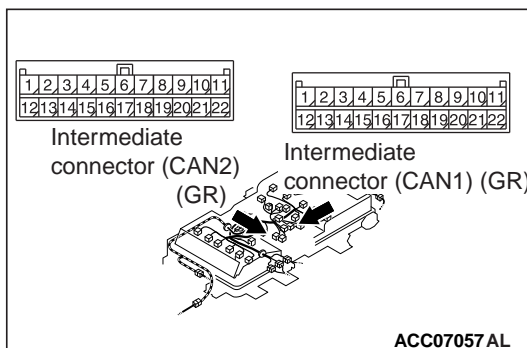
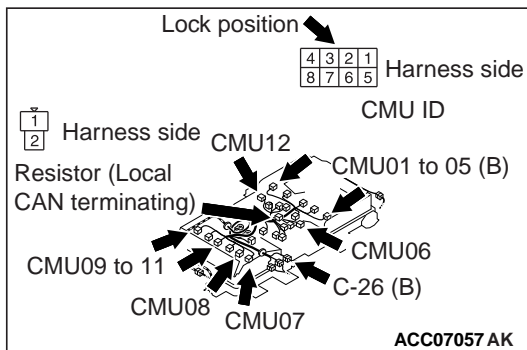

STEP 11. Check the wiring harness between C-26 (terminal No. 10) main drive lithium-ion battery connector and CMU12 from CMU01 (terminal No. 4) connector, BMU (terminal No.23) connector, resistor (local CAN terminating) (terminal No. 2) connector

NOTE:

- Before checking harness, check intermediate connector (CAN1) terminal No. 22 from No. 14, intermediate connector (CAN2) terminal No. 20 from No. 13 of out signal line, and repair if necessary.

Check signal line (CANL) for open circuit.

Q: Is the check result normal?

YES : Go to Step 12.

NO : Repair the wiring harness.

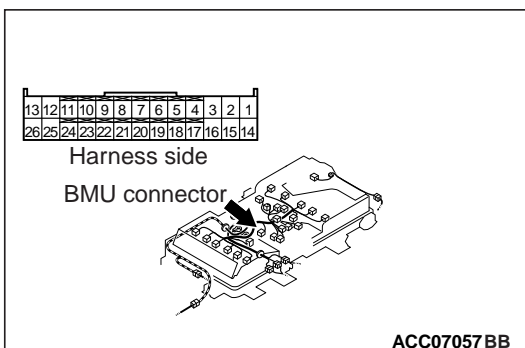
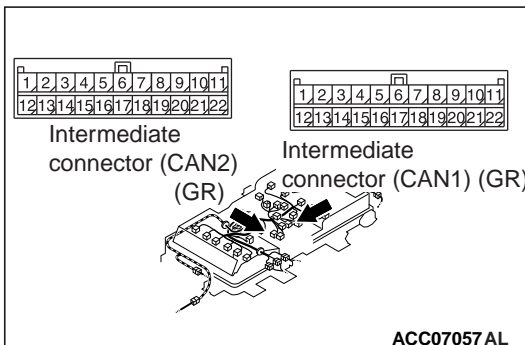
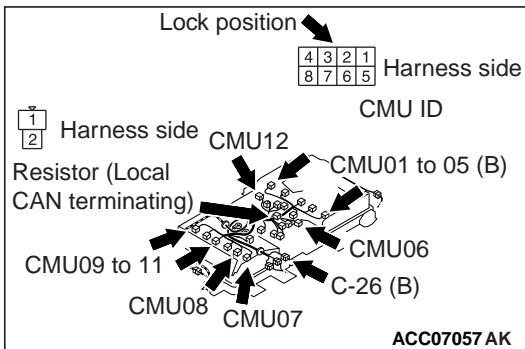

STEP 12. Check the local CAN (for main drive lithium-ion battery) terminating resistor

- (1) Removal the local CAN terminating resistor in main drive lithium-ion battery (Refer to [P.54D-189](#)).
- (2) Check the local CAN terminating resistor in main drive lithium-ion battery (Refer to [P.54D-217](#)).

Q: Is the check result normal?**YES** : Go to Step 13.**NO** : Replace the local CAN terminating resistor (Refer to [P.54D-209](#)).

STEP 13. Use scan tool MB991958 to confirm a diagnostic trouble code.**Q: Is the diagnostic trouble code set?****YES** : Replace the BMU (Refer to [P.54D-188](#)).**NO** : Intermittent malfunction (Refer to GROUP 00 – How to Use Troubleshooting/Inspection Service Points, How to Cope with Intermittent Malfunctions).

DTC P1AA9 Cell Number Mismatch

TROUBLE JUDGMENT**Check Conditions**

- When the CMUs are numbered for identification.
- The following diagnostic trouble code is set at the same time.
 - a. U1925: CMU ID numbering reception error

Judgment Criterion

- The number of cells are invalid.

FAIL-SAFE AND BACKUP FUNCTION

- Not available

PROBABLE CAUSES

- Improper installation of the main drive lithium-ion battery.
- The BMU is failed.

DIAGNOSIS

STEP 1. Scan tool MB991958 other diagnostic trouble code.

Check if DTC U1925 is set.

Q: Is the diagnostic trouble code set?**YES** : Carry out troubleshooting for DTC U1925 (Refer to [P.54D-175](#)).**NO** : Go to Step 2.

STEP 2. Use scan tool MB991958 to confirm a diagnostic trouble code.

Q: Is the diagnostic trouble code set?

YES : Replace the BMU (Refer to [P.54D-188](#)).

NO : Go to Step 3.

STEP 3. Use scan tool MB991958 to confirm a diagnostic trouble code.

(1) Select "CMU ID numbering" on the special function screen of the BMU, and execute it.

Q: Is the diagnostic trouble code set?

YES : Replace the main drive lithium-ion battery assembly.

NO : Intermittent malfunction (Refer to GROUP 00 – How to Use Troubleshooting/Inspection Service Points – How to Cope with Intermittent Malfunctions).

DTC P1AB5 CMU01 Battery Low Temperature, P1AB6 CMU02 Battery Low Temperature, P1AB7 CMU03 Battery Low Temperature, P1AB8 CMU04 Battery Low Temperature, P1AB9 CMU05 Battery Low Temperature, P1ABA CMU06 Battery Low Temperature, P1ABB CMU07 Battery Low Temperature, P1ABC CMU08 Battery Low Temperature, P1ABD CMU09 Battery Low Temperature, P1ABE CMU10 Battery Low Temperature, P1ABF CMU11 Battery Low Temperature, P1AC0 CMU12 Battery Low Temperature

TROUBLE JUDGMENT

Check Conditions

- 3 seconds elapse after the electric motor switch is turned ON, or 3 seconds elapse after the main drive lithium-ion battery starts to be charged.
- Either one of the following diagnostic trouble codes is not set.
 - a. P1AA8: Bat-CAN signal time out
 - b. U1082: Bat-CAN bus-off

Judgment Criterion

- The module temperature is less than -30°C (-22°F).

FAIL-SAFE AND BACKUP FUNCTION

- Not available

PROBABLE CAUSE

- The module (battery cell, CMU and module temperature sensor) in the main drive lithium-ion battery is failed.

DIAGNOSIS

STEP 1. Scan tool MB991958 data list

- Check the data list reference table corresponding to the diagnostic trouble code.

OK: At ambient temperature (atmospheric temperature) or equivalent (when the vehicle driving and the charge are not performed for a long time)

Q: Is the check result normal?

YES : Intermittent malfunction (Refer to GROUP 00 – How to Use Troubleshooting/Inspection Service Points – How to Cope with Intermittent Malfunctions).

NO : Go to Step 2.

STEP 2. Scan tool MB991958 data list of others system

- (1) Select "Reset" for the relevant CMU ID on the special function screen (Refer to GROUP 00 – Precautions Before Service, How to Reset Failure Information in the CMU EEPROM), and then execute it.
- (2) Check the data list on the relevant CMU ID.
 - Item No. 14: Reference low voltage
 - Item No. 15: Reference high voltage
 - Item No. 16 – No. 21: Temperature sensor (1 – 6) (open)
 - Item No. 22 – No. 27: Temperature sensor (1 – 6) (short)
 - Item No. 44 – No. 49: Temperature sensor (1 – 6) under-flow
 - Item No. 50 – No. 55: Temperature sensor (1 – 6) over-flow
 - Item No. 67: A/D conversion (Reference volt)
 - Item No. 68 – No. 73: A/D conversion (temp. sensor 1 – 6)

Q: Is the check result normal?

YES : Intermittent malfunction (Refer to GROUP 00 – How to Use Troubleshooting/Inspection Service Points – How to Cope with Intermittent Malfunctions).

NO : Check to tighten the bus bar in the main drive lithium-ion battery or replace the main drive lithium-ion battery.

DTC P1AC1 Battery Cooling Fan (Drive Fail)

TROUBLE JUDGMENT

Check Conditions

- The electric motor switch is ON position or while the main drive lithium-ion battery is charged.

Judgment Criterion

- For more than 5 seconds, the PWM output signal of the main drive lithium-ion battery fan is 10 percent (while the fan is being driven). The output of the rotational speed is less than 2 volts (less than 1,645 r/min or equivalent).

FAIL-SAFE AND BACKUP FUNCTION

- Not available

PROBABLE CAUSES

- The main drive lithium-ion battery fan relay is failed.
- The main drive lithium-ion battery fan is failed.
- Open circuits of main drive lithium-ion battery fan relay circuit, short circuits to ground or damage; poor contact of connector.
- Open circuits of main drive lithium-ion battery fan circuit, short circuits to ground or damage; poor contact of connector.
- The BMU is failed.

DIAGNOSIS

STEP 1. Connector check: A-115X main drive lithium-ion battery fan relay connector

Q: Is the check result normal?

YES : Go to Step 2.

NO : Repair the connector.

STEP 2. Check main drive lithium-ion battery fan relay itself.

- Check main drive lithium-ion battery fan relay itself.

Q: Is the check result normal?

YES : Go to Step 3.

NO : Replace the main drive lithium-ion battery fan relay.

STEP 3. Perform voltage measurement at A-115X main drive lithium-ion battery fan relay

- Remove the relay, and measure at relay box side.
- Voltage between terminal No.4 and ground.

OK: System voltage

Q: Is the check result normal?

YES : Go to Step 4.

NO : Check and repair harness between 12V starter battery and A-115X (terminal No.4) main drive lithium-ion battery fan relay connector.

- Check power supply line for open circuit, short circuit to ground

STEP 4. Connector check: C-14 main drive lithium-ion battery connector, A-107 intermediate connector

Q: Is the check result normal?

YES : Go to Step 5.

NO : Repair the connector.

STEP 5. Perform voltage measurement at C-14 main drive lithium-ion battery connector

- Disconnect connector, and measure at harness side.
- Remove the A-115X main drive lithium-ion battery fan relay, and short-circuit the terminal No.4 – 3 at the relay box side.
- Voltage between terminal No.1 and ground.

OK: System voltage

Q: Is the check result normal?

YES : Go to Step 6.

NO : Check intermediate connector A-107, and repair if necessary. If intermediate connector is normal, check and repair harness between A-115X (terminal No.3) main drive lithium-ion battery fan relay connector and C-14 (terminal No.1) main drive lithium-ion battery connector.

- Check output line for open circuit, short circuit to ground.

STEP 6. Perform resistance measurement at C-14 main drive lithium-ion battery connector

- Disconnect connector, and measure at harness side.
- Resistance between terminal No.4 and ground.

OK: Continuity (2 Ω less)

Q: Is the check result normal?

YES : Go to Step 7.

NO : Check and repair harness between C-14 (terminal No.4) main drive lithium-ion battery connector and body ground.

- Check grounding line for open circuit and damage.

STEP 7. Check the wiring harness between 12V starter battery and A-115X (terminal No.4) main drive lithium-ion battery fan relay connector

- Check power supply line for damage.

Q: Is the check result normal?

YES : Go to Step 8.

NO : Repair the wiring harness.

STEP 8. Check the wiring harness between A-115X (terminal No.3) main drive lithium-ion battery fan relay connector and C-14 (terminal No.1) main drive lithium-ion battery connector

NOTE: Before checking the wiring harness, check intermediate connector A-107, and repair if necessary.

- Check output line for damage.

Q: Is the check result normal?

YES : Go to Step 9.

NO : Repair the wiring harness.

STEP 9. Perform voltage measurement at C-21 main drive lithium-ion battery connector

- Measure main drive lithium-ion battery terminal voltage.
- Right after starting the regular charge.
- Voltage between terminal No.8 and ground.

OK: 2 volts or more → 1 volt or less (After several seconds elapse)

Q: Is the check result normal?

YES : Go to Step 11.

NO : Go to Step 10.

STEP 10. Scan tool MB991958 data list

- Refer to Data List Reference Table.
 - a. Item 32: Battery cooling fan rotations

Q: Is the check result normal?

YES : Intermittent malfunction (Refer to GROUP 00 – How to Use Troubleshooting/Inspection Service Points, How to Cope with Intermittent Malfunctions).

NO : Replace the BMU (Refer to [P.54D-188](#)).

STEP 11. Connector check: C-21 main drive lithium-ion battery connector

Q: Is the check result normal?

YES : Go to Step 12.

NO : Repair the connector.

STEP 12. Check harness between C-14 (terminal No. 3) main drive lithium-ion battery connector and C-21 (terminal No.8) main drive lithium-ion battery connector

- Check output line for open circuit, short circuit to ground and damage.

Q: Is the check result normal?

YES : Go to Step 13.

NO : Repair the wiring harness.

STEP 13. Connector check: BMU connector, main drive lithium-ion battery cooling fan connector

Removal the main drive lithium-ion battery cover (Refer to [P.54D-194](#)).

Q: Is the check result normal?

YES : Go to Step 14.

NO : Repair the connector.

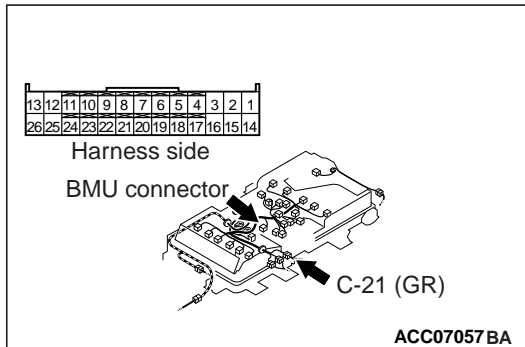
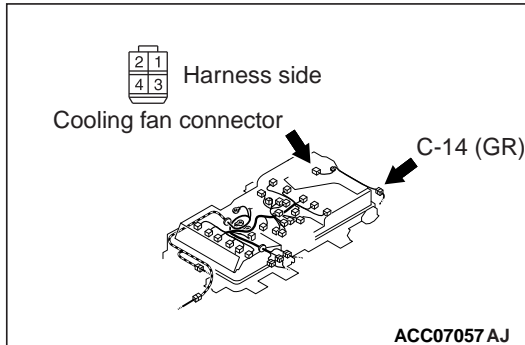

STEP 14. Check harness between main drive lithium-ion battery fan connector (terminal No.1) and C-14 (terminal No.3) main drive lithium-ion battery connector, between C-21 (terminal No.8) main drive lithium-ion battery connector and BMU connector (terminal No.11)

- Check output line for open circuit, short circuit to earth and damage.

Q: Is the check result normal?

YES : Go to Step 15.

NO : Repair the wiring harness.

STEP 15. Use scan tool MB991958 to confirm a diagnostic trouble code.

Q: Is the diagnostic trouble code set?

YES : Replace the cooling fan in the main drive lithium-ion battery (Refer to [P.54D-211](#)).

NO : Intermittent malfunction (Refer to GROUP 00 – How to Use Troubleshooting/Inspection Service Points – How to Cope with Intermittent Malfunctions).

DTC P1AC2 Battery Cooling Fan (SHT to BAT)

TROUBLE JUDGMENT

Check Conditions

- The electric motor switch is ON position or while the main drive lithium-ion battery is charged.

Judgment Criterion

- For more than 5 seconds, the PWM output signal of the main drive lithium-ion battery fan is 10 percent (while the fan is being driven). The output of the rotational speed is more than 5 volts (more than 4,112 r/min or equivalent).

FAIL-SAFE AND BACKUP FUNCTION

- Not available

PROBABLE CAUSE

- The main drive lithium-ion battery fan relay is failed.
- Open circuits of main drive lithium-ion battery fan relay circuit, short circuits to ground or damage; poor contact of connector.
- The main drive lithium-ion battery fan is failed.
- Short circuits to power supply system of main drive lithium-ion battery fan circuit; poor contact of connector.
- The BMU is failed.

DIAGNOSIS

STEP 1. Connector check: A-115X main drive lithium-ion battery fan relay connector

Q: Is the check result normal?

YES : Go to Step 2.

NO : Repair the connector.

STEP 2. Check main drive lithium-ion battery fan relay itself.

- Check main drive lithium-ion battery fan relay itself.

Q: Is the check result normal?

YES : Go to Step 3.

NO : Replace the main drive lithium-ion battery fan relay.

STEP 3. Perform voltage measurement at A-115X main drive lithium-ion battery fan relay

- Remove the relay, and measure at relay box side.
- Voltage between terminal No.4 and ground.

OK: System voltage

Q: Is the check result normal?

YES : Go to Step 4.

NO : Check and repair harness between 12V starter battery and A-115X (terminal No.4) main drive lithium-ion battery fan relay connector.

- Check power supply line for open circuit, short circuit to ground.

STEP 4. Connector check: C-14 main drive lithium-ion battery connector, A-107 intermediate connector

Q: Is the check result normal?

YES : Go to Step 5.

NO : Repair the connector.

STEP 5. Perform voltage measurement at C-14 main drive lithium-ion battery connector

- Disconnect connector, and measure at harness side.
- Remove the A-115X main drive lithium-ion battery fan relay, and short-circuit the terminal No.4 – 3 at the relay box side.
- Voltage between terminal No.1 and ground.

OK: System voltage

Q: Is the check result normal?

YES : Go to Step 6.

NO : Check intermediate connector A-107, and repair if necessary. If intermediate connector is normal, check and repair harness between A-115X (terminal No.3) main drive lithium-ion battery fan relay connector and C-14 (terminal No.1) main drive lithium-ion battery connector.

- Check output line for open circuit, short circuit to ground.

STEP 6. Check the wiring harness between 12V starter battery and A-115X (terminal No. 4) main drive lithium-ion battery fan relay connector

- Check power supply line for damage.

Q: Is the check result normal?

YES : Go to Step 7.

NO : Repair the wiring harness.

STEP 7. Check the wiring harness between A-115X (terminal No.3) main drive lithium-ion battery fan relay connector and C-14 (terminal No.1) main drive lithium-ion battery connector

NOTE: Before checking the wiring harness, check intermediate connector A-107, and repair if necessary.

- Check output line for damage.

Q: Is the check result normal?

YES : Go to Step 8.

NO : Repair the wiring harness.

STEP 8. Perform voltage measurement at C-21 main drive lithium-ion battery connector

- Measure main drive lithium-ion battery terminal voltage.
- Disconnect C-14 main drive lithium-ion battery connector.
- Electric motor switch: ON
- Voltage between terminal No.8 and ground.

OK: 0 – 0.1 volt

Q: Is the check result normal?

YES : Go to Step 10.

NO : Go to Step 9.

STEP 9. Connector check: C-21 main drive lithium-ion battery connector

Q: Is the check result normal?

YES : Check and repair harness between C-14 (terminal No.3) main drive lithium-ion battery connector and C-21 (terminal No.8) main drive lithium-ion battery connector.

- Check output line for short circuit to power supply.

NO : Repair the connector.

STEP 10. Perform voltage measurement at C-21 main drive lithium-ion battery connector

- Measure main drive lithium-ion battery terminal voltage.
- Right after starting the regular charge.
- Voltage between terminal No.8 and ground.

OK: 5 volts or less (while the main drive lithium-ion battery fan is driving)

Q: Is the check result normal?

YES : Go to Step 11.

NO : Go to Step 12.

STEP 11. Use scan tool MB991958 to confirm a diagnostic trouble code.

Q: Is the diagnostic trouble code set?

YES : Replace the BMU (Refer to [P.54D-188](#)).

NO : Intermittent malfunction (Refer to GROUP 00 – How to Use Troubleshooting/Inspection Service Points, How to Cope with Intermittent Malfunctions).

STEP 12. Connector check: BMU connector, main drive lithium-ion battery cooling fan connector

Removal the main drive lithium-ion battery cover (Refer to [P.54D-194](#)).

Q: Is the check result normal?

YES : Go to Step 13.

NO : Repair the connector.

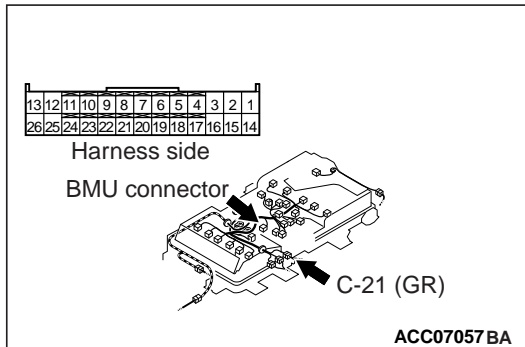
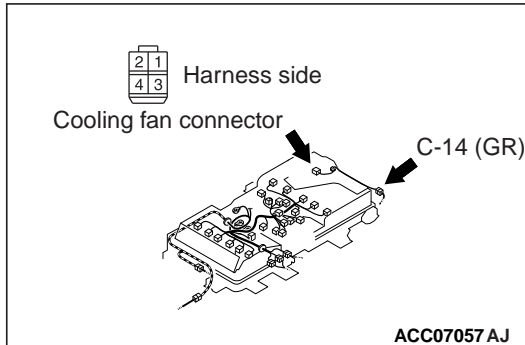

STEP 13. Check harness between main drive lithium-ion battery fan connector (terminal No.1) and C-14 (terminal No.3) main drive lithium-ion battery connector, between C-21 (terminal No.8) main drive lithium-ion battery connector and BMU connector (terminal No.11)

- Check output line for open circuit, short circuit to earth and damage.

Q: Is the check result normal?

YES : Go to Step 14.

NO : Repair the wiring harness.

STEP 14. Use scan tool MB991958 to confirm a diagnostic trouble code.

Q: Is the diagnostic trouble code set?

YES : Replace the cooling fan in the main drive lithium-ion battery (Refer to [P.54D-211](#)).

NO : Intermittent malfunction (Refer to GROUP 00 – How to Use Troubleshooting/Inspection Service Points – How to Cope with Intermittent Malfunctions).

DTC P1AC3 Battery Cooling Fan (Rest Fail)

TROUBLE JUDGMENT

Check Conditions

- The electric motor switch is ON position or while the main drive lithium-ion battery is charged.

Judgment Criterion

- For more than 5 seconds, the PWM output signal of the main drive lithium-ion battery fan is 100 percent (while the fan stops). The output of the rotational speed is more than 0.7 volt (more than 493 r/min or equivalent).

FAIL-SAFE AND BACKUP FUNCTION

- Not available

PROBABLE CAUSES

- The main drive lithium-ion battery fan is failed.
- Open circuits of main drive lithium-ion battery fan relay circuit, short circuits to power supply system or damage; poor contact of connector.
- The BMU is failed.

DIAGNOSIS

STEP 1. Connector check: C-21 main drive lithium-ion battery, C-14 main drive lithium-ion battery fan connector

Q: Is the check result normal?

YES : Go to Step 2.

NO : Repair the connector.

STEP 2. Check harness between C-14 (terminal No.2) main drive lithium-ion battery connector and C-21 (terminal No.7) main drive lithium-ion battery connector

- Check signal line for open circuit and damage.

Q: Is the check result normal?

YES : Go to Step 3.

NO : Repair the wiring harness.

STEP 3. Perform voltage measurement at C-21 main drive lithium-ion battery connector

- Measure main drive lithium-ion battery terminal voltage.
- Disconnect C-14 main drive lithium-ion battery connector.
- Electric motor switch: ON
- Voltage between terminal No.8 and ground.

OK: 0 – 0.1 volt

Q: Is the check result normal?

YES : Go to Step 5.

NO : Go to Step 4.

STEP 4. Connector check: C-21 main drive lithium-ion battery connector

Q: Is the check result normal?

YES : Check and repair harness between C-14 (terminal No.3) main drive lithium-ion battery connector and C-21 (terminal No.8) main drive lithium-ion battery connector.

- Check output line for short circuit to power supply.

NO : Repair the connector.

STEP 5. Perform voltage measurement at C-21 main drive lithium-ion battery connector

- Measure main drive lithium-ion battery terminal voltage.
- Right after starting the regular charge.
- Voltage between terminal No.8 and ground.

OK: 5 volt or less (while the main drive lithium-ion battery fan is driving)

Q: Is the check result normal?

YES : Go to Step 6.

NO : Go to Step 7.

STEP 6. Use scan tool MB991958 to confirm a diagnostic trouble code.**Q: Is the diagnostic trouble code set?**

YES : Replace the BMU (Refer to [P.54D-188](#)).

NO : Intermittent malfunction (Refer to GROUP 00 – How to Use Troubleshooting/Inspection Service Points, How to Cope with Intermittent Malfunctions).

STEP 7. Connector check: BMU connector, main drive lithium-ion battery cooling fan connector

Removal the main drive lithium-ion battery cover (Refer to [P.54D-194](#)).

Q: Is the check result normal?

YES : Go to Step 8.

NO : Repair the connector.

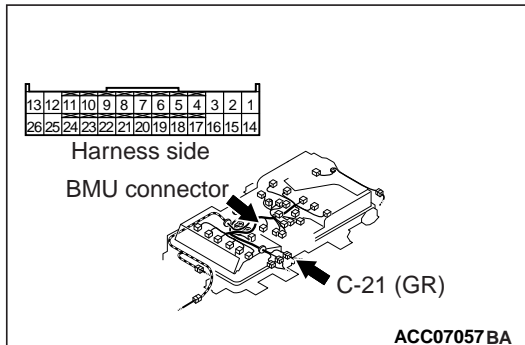
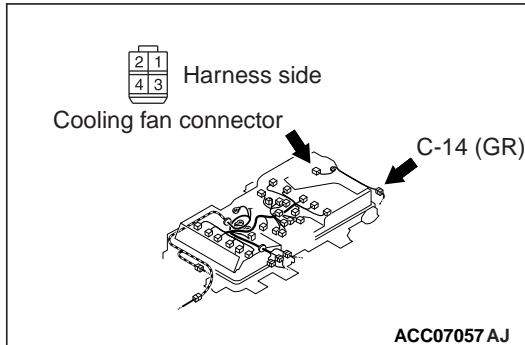

STEP 8. Check harness between main drive lithium-ion battery fan connector (terminal No.1) and C-14 (terminal No.3) main drive lithium-ion battery connector, between C-21 (terminal No.8) main drive lithium-ion battery connector and BMU connector (terminal No.11)

- Check output line for open circuit, short circuit to earth and damage.

Q: Is the check result normal?

YES : Go to Step 9.

NO : Repair the wiring harness.

STEP 9. Use scan tool MB991958 to confirm a diagnostic trouble code.

Q: Is the diagnostic trouble code set?

YES : Replace the cooling fan in the main drive lithium-ion battery (Refer to P.54D-211).

NO : Intermittent malfunction (Refer to GROUP 00 – How to Use Troubleshooting/Inspection Service Points – How to Cope with Intermittent Malfunctions).

DTC P1AC6 Each Cell VOLT. Diff. (HI Side)

TROUBLE JUDGMENT

Check Conditions

- 3 seconds elapse after the electric motor switch is turned ON, or 3 seconds elapse after the main drive lithium-ion battery starts to be charged.
- The absolute value of the current is less than 1 ampere.
- The battery total voltage is more than 350 volts.
- Either one of the following diagnostic trouble codes is not set.

- a. P1AA8: Bat-CAN signal time out
- b. U1082: Bat-CAN bus-off

Judgment Criterion

- Difference in voltage values each battery cell is more than 0.05 volt

NOTE: If the module is replaced, a diagnostic trouble code will be always set, because the state of the new battery cell is different from others. This diagnostic trouble code does not indicate a malfunction.

FAIL-SAFE AND BACKUP FUNCTION

- Not available

PROBABLE CAUSE

- The module (battery cell and CMU) in the main drive lithium-ion battery is failed.

DIAGNOSIS

STEP 1. Scan tool MB991958 other diagnostic trouble code.

Confirm whether DTC P1A4B is set in the BMU.

Q: Is the diagnostic trouble code set?

YES : Perform the troubleshooting of DTC P1A4B.

NO : Go to Step 2.

STEP 2. Main drive lithium-ion battery condition check**Q: Does replace the module in the main drive lithium-ion battery recently?**

YES : Erase the DTC, check end.

NO : Go to Step 3.

STEP 3. Scan tool MB991958 data list

Refer to Data List Reference Table.

- Item No. 6: Minimum voltage cell ID
- Item No. 7: Battery total voltage

OK: Total battery voltage of 350 volts or more

Q: Is check result normal?

YES : Go to Step 4.

NO : Go to Step 5.

STEP 4. Scan tool MB991958 data list of others system

- (1) Select "Reset" for ID of the cell of the lowest voltage (CMU ID) on the special function screen (Refer to GROUP 00 – Precautions Before Service, How to Reset Failure Information in the CMU EEPROM), and then execute it.
- (2) Check the data list corresponding to the cell ID of lowest voltage.

Q: Is the check result normal?

YES : Go to Step 5.

NO : Replace the main drive lithium-ion battery assembly.

STEP 5. Use scan tool MB991958 to confirm a diagnostic trouble code.

Charge and discharge the main drive lithium-ion battery. Then reconfirm whether the diagnostic trouble code is set in the BMU.

1. Erase the diagnostic trouble codes being set.
2. The total voltage of the battery should be 350 volts when the system is deenergized.

NOTE:

- If the total voltage exceeds 350 volts, activate the air conditioning system to discharge the battery.
- If the total voltage is under 350 volts, charge the battery in the regular manner.

3. After 10 seconds, confirm whether the diagnostic trouble codes are set.

Q: Is the diagnostic trouble code set?

YES : Replace the main drive lithium-ion battery assembly.

NO : Intermittent malfunction (Refer to GROUP 00 – How to Use Troubleshooting/Inspection Service Points, How to Cope with Intermittent Malfunctions).

DTC P1ADF +B Line Voltage

TROUBLE JUDGMENT

Check Condition

- Every time after the BMU is activated.

Judgment Criterion

- The BMU control power supply voltage is less than 8 volts.
- or
- The BMU control power supply voltage is more than 16 volts.

FAIL-SAFE AND BACKUP FUNCTION

- Not available

PROBABLE CAUSES

- The 12V starter battery is failed.

- When starting at the voltage more than 16 volts from the outside of the vehicle.
- The installation of the 12V starter battery terminal is failed.
- Open circuits of BMU control power supply circuit, short circuits to ground or damage; poor contact of connector
- The BMU is failed.

DIAGNOSIS

STEP 1. 12V starter battery condition check

Q: Does the 12V starter battery start at the voltage more than 16 volts from the outside of the vehicle recently?

YES : Erase the diagnostic trouble code, check end.

NO : Go to Step 2.

STEP 2. 12V starter battery condition check

Q: Is the installation status of the 12V starter battery terminal abnormal?

YES : Repair.

NO : Go to Step 3.

STEP 3. Check 12V starter battery

- Check 12V starter battery (Refer to GROUP 54A – 12V starter battery – On-vehicle Service – Battery Test).

Q: Is the check result normal?

YES : Go to Step 4.

NO : Replace the 12V starter battery.

STEP 4. Connector check: C-26 main drive lithium-ion battery connector

Q: Is the check result normal?

YES : Go to Step 5.

NO : Repair the connector.

STEP 5. Perform voltage measurement at C-26 main drive lithium-ion battery connector

- Disconnect connector, and measure at harness side.
- Voltage between terminal No.1 and ground.

OK: System voltage

Q: Is the check result normal?

YES : Go to Step 6.

NO : Check intermediate connectors A-107, and repair if necessary. If intermediate connectors are normal, check and repair harness between C-26 (terminal No.1) main drive lithium-ion battery connector and 12V starter battery.

- Check power supply line for open circuit, short circuit to ground.

STEP 6. Connector check: BMU connector

Removal the main drive lithium-ion battery cover (Refer to [P.54D-194](#)).

Q: Is the check result normal?

- YES** : Go to Step 7.
- NO** : Repair the connector.

STEP 7. Check the wiring harness between BMU connector (terminal No.1) and C-26 main drive lithium-ion battery connector (terminal No.1)

Check power supply for open or short circuit.

Q: Is the check result normal?

- YES** : Go to Step 8.
- NO** : Repair the wiring harness.

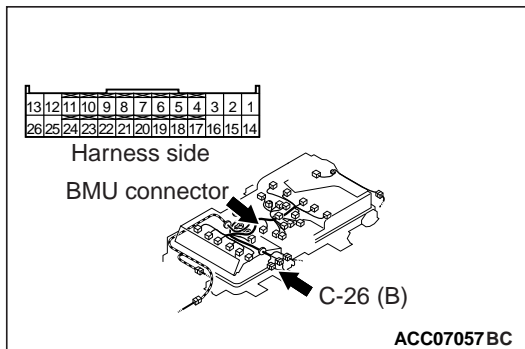

STEP 8. Use scan tool MB991958 to confirm a diagnostic trouble code.

Q: Is the diagnostic trouble code set?

- YES** : Replace the BMU (Refer to [P.54D-188](#)).
- NO** : Intermittent malfunction (Refer to GROUP 00 – How to Use Troubleshooting/Inspection Service Points, How to Cope with Intermittent Malfunctions).

DTC P1AE0 Clock IC Time Counter

TROUBLE JUDGMENT

Check Condition

- After the electric motor switch is turned ON, or after the main drive lithium-ion battery starts to be charged.
- Thirty minutes have passed since the BMU was activated.

Judgment Criterion

- The system detects an error in the counter function.

FAIL-SAFE AND BACKUP FUNCTION

- Not available

PROBABLE CAUSE

- The BMU (clock IC) is failed.

DIAGNOSIS

STEP 1. Scan tool MB991958 other diagnostic trouble code.

Reconfirm whether the diagnostic trouble codes are set in the BMU.

1. Erase the diagnostic trouble codes being set.
2. Electric motor switch: LOCK (OFF) → ON
3. Confirm whether the diagnostic trouble codes are set.

Q: Is the diagnostic trouble code set?

YES : Replace the BMU (Refer to [P.54D-188](#)).

NO : Intermittent malfunction (Refer to GROUP 00 – How to Use Troubleshooting/Inspection Service Points, How to Cope with Intermittent Malfunctions).

DTC P1AE1 Clock IC Alarm

TROUBLE JUDGMENT

Check Condition

- After the electric motor switch is turned ON, or after the main drive lithium-ion battery starts to be charged.
- At least 6 hours have passed since the last time the BMU was deactivated.

Judgment Criterion

- The system detects an error in the alarm function.

FAIL-SAFE AND BACKUP FUNCTION

- Not available

PROBABLE CAUSE

- The BMU (clock IC) is failed.

DIAGNOSIS

STEP 1. Scan tool MB991958 other diagnostic trouble code.

Reconfirm whether the diagnostic trouble codes are set in the BMU.

1. Erase the diagnostic trouble codes being set.
2. Electric motor switch: LOCK (OFF) → ON after at least 6 hours have passed
3. Confirm whether the diagnostic trouble codes are set.

Q: Is the diagnostic trouble code set?

YES : Replace the BMU (Refer to [P.54D-188](#)).

NO : Intermittent malfunction (Refer to GROUP 00 – How to Use Troubleshooting/Inspection Service Points, How to Cope with Intermittent Malfunctions).

DTC P1AE3 BMU TEMP. Sensor (Open/Short)

TROUBLE JUDGMENT

Check Condition

- After the electric motor switch is turned ON, or after the main drive lithium-ion battery starts to be charged.

Judgment Criterion

- The system detects an error in the BMU temperature sensor.

FAIL-SAFE AND BACKUP FUNCTION

- Not available

PROBABLE CAUSE

- The BMU (temperature sensor) is failed.

DIAGNOSIS

STEP 1. Scan tool MB991958 other diagnostic trouble code.

Reconfirm whether the diagnostic trouble codes are set in the BMU.

1. Erase the diagnostic trouble codes being set.
2. Electric motor switch: LOCK (OFF) → ON
3. Confirm whether the diagnostic trouble codes are set.

Q: Is the diagnostic trouble code set?

YES : Replace the BMU (Refer to [P.54D-188](#)).

NO : Intermittent malfunction (Refer to GROUP 00 – How to Use Troubleshooting/Inspection Service Points, How to Cope with Intermittent Malfunctions).

DTC P1AE4 BMU TEMP. Sensor (Rationality)

TROUBLE JUDGMENT

Check Condition

- Immediately after the BMU is activated.
- At least 6 hours have passed since the last time the BMU was deactivated.
- The system communicates with the CMU via local CAN.
- None of the other DTC P1A82 to P1A8D, P1AE0 or P1AE1 is not set.

Judgment Criterion

- The system detects an error in the BMU temperature sensor.

FAIL-SAFE AND BACKUP FUNCTION

- Not available

PROBABLE CAUSE

- The BMU (temperature sensor) is failed.

DIAGNOSIS

STEP 1. Scan tool MB991958 other diagnostic trouble code.

Confirm whether DTC P1AE3 is set in the BMU.

Q: Is the diagnostic trouble code set?

YES : Perform the troubleshooting of DTC P1AE3.

NO : Go to Step 2.

STEP 2. Use scan tool MB991958 to confirm a diagnostic trouble code.

Reconfirm whether the diagnostic trouble codes are set in the BMU.

1. Erase the diagnostic trouble codes being set.
2. Electric motor switch: LOCK (OFF) → ON after at least 6 hours have passed
3. Confirm whether the diagnostic trouble codes are set.

Q: Is the diagnostic trouble code set?

YES : Replace the BMU (Refer to [P.54D-188](#)).

NO : Intermittent malfunction (Refer to GROUP 00 – How to Use Troubleshooting/Inspection Service Points – How to Cope with Intermittent Malfunctions).

DTC U1082 Bat-CAN Bus-Off

TROUBLE JUDGMENT**Check Condition**

- 3 seconds elapse after the electric motor switch is turned ON, or 3 seconds elapse after the main drive lithium-ion battery starts to be charged.

Judgment Criterion

- When the bus off of the BMU is judged.

FAIL-SAFE AND BACKUP FUNCTION

- Not available

PROBABLE CAUSES

- The harnesses and connectors are failed.
- The Local CAN (for main drive lithium-ion battery) bus is failed.
- The BMU is failed.

DIAGNOSIS

STEP 1. Check the local CAN (for main drive lithium-ion battery) terminating resistance itself

- Check the local CAN (for main drive lithium-ion battery) terminating resistance itself (Refer to P.54D-185).

Q: Is the check result normal?

- YES** : Go to Step 6.
NO : Go to Step 2.

STEP 2. Connector check: CMU12 from CMU01 connector, BMU connector, resistor (local CAN terminating) connector

Removal of the main drive lithium-ion battery cover (Refer to P.54D-194).

Q: Is the check result normal?

- YES** : Go to Step 3.
NO : Repair the damaged connector.

STEP 3. Perform resistance measurement at intermediate (CAN1) or intermediate (CAN2) connector

- Ensure that the positive and negative battery terminals of the auxiliary battery are disconnected.
- Disconnect mail terminal of intermediate connector (CAN1), and measure at wiring harness side.
- Resistance between terminal No.4 and No.15, terminal No.5 and No.16, terminal No.6 and No.17, terminal No.7 and No.18, terminal No.8 and No.19, terminal No.9 and No.20, terminal No.10 and No.21, terminal No.11 and No.22.
- Disconnect mail terminal of intermediate connector (CAN2), and measure at wiring harness side.
- Resistance between terminal No.2 and No.13, terminal No.4 and No.15, terminal No.5 and No.16, terminal No.6 and No.17, terminal No.7 and No.18, terminal No.8 and No.19.

OK: $120 \pm 20 \Omega$

Q: Is the check result normal?

- YES** : Go to Step 5.
NO : Go to Step 4.

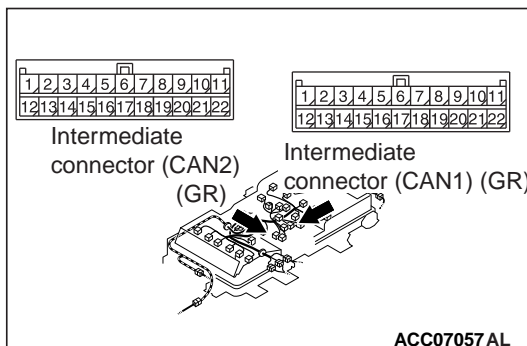

STEP 4. Perform resistance measurement at BMU connector, CMU12 from CMU01 connector, resistor (local CAN terminating) connector

- Disconnect BMU connector, and resistance measurement between terminal No.23 and No.24 at BMU side.
- Disconnect CMU12 from CMU01 connector, and resistance measurement between terminal No.4 and No.8 at CMU12 from CMU01 connector side.
- Disconnect resistor (local CAN terminating) connector, and resistance measurement between terminal No.1 and No.2 at resistor (local CAN terminating) connector side.

OK: $120 \pm 20 \Omega$ **Q: Is the check result normal?**

YES : Repair the wiring harness between intermediate connector (CAN1), intermediate connector (CAN2) and BMU connector, CMU12 from CMU01 connector, resistor (local CAN terminating) connector.

NO : Replace the BMU, CMU12 from CMU01, resistor (local CAN terminating) (Refer to [P.54D-189](#)).

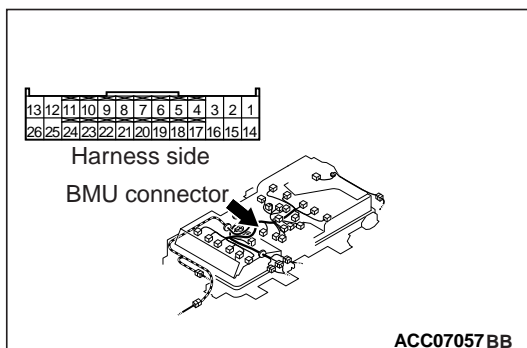
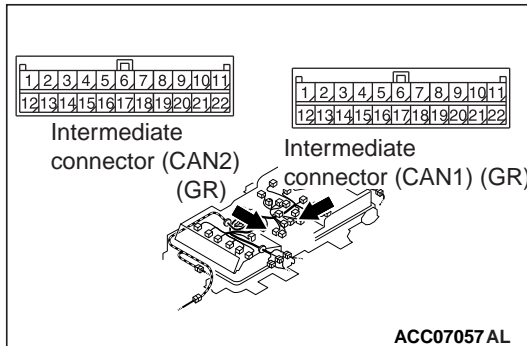
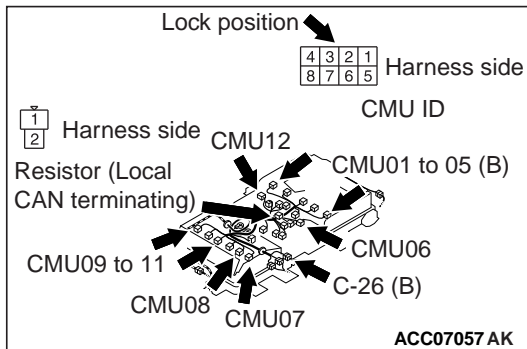

STEP 5. Check the local CAN (for main drive lithium-ion battery) terminating resistor

- (1) Removal the local CAN terminating resistor in main drive lithium-ion battery (Refer to [P.54D-189](#)).
- (2) Check the local CAN terminating resistor in main drive lithium-ion battery (Refer to [P.54D-217](#)).

Q: Is the check result normal?

YES : Intermittent malfunction (Refer to GROUP 00 – How to Use Troubleshooting/Inspection Service Points – How to Cope with Intermittent Malfunctions).

NO : Replace the local CAN terminating resistor (Refer to [P.54D-209](#)).

STEP 6. Use scan tool MB991958 to confirm a diagnostic trouble code.

Reconfirm whether the diagnostic trouble codes are set in the BMU.

1. Erase the diagnostic trouble codes being set.
2. Electric motor switch: LOCK (OFF) → ON
3. Confirm whether the diagnostic trouble codes are set.

Q: Is the diagnostic trouble code set?

YES : Replace the BMU (Refer to [P.54D-188](#)). Then go to Step 7.

NO : Intermittent malfunction (Refer to GROUP 00 – How to Use Troubleshooting/Inspection Service Points, How to Cope with Intermittent Malfunctions).

STEP 7. Use scan tool MB991958 to confirm a diagnostic trouble code.

Reconfirm whether the diagnostic trouble codes are set in the BMU.

1. Erase the diagnostic trouble codes being set.
2. Electric motor switch: LOCK (OFF) → ON
3. Confirm whether the diagnostic trouble codes are set.

Q: Is the diagnostic trouble code set?

YES : Go to Step 1.

NO : Check end.

DTC U11A0 CMU01 CAN Timeout, U11A1 CMU02 CAN Timeout, U11A2 CMU03 CAN Timeout, U11A3 CMU04 CAN Timeout, U11A4 CMU05 CAN Timeout, U11A5 CMU06 CAN Timeout, U11A6: CMU07 CAN Timeout, U11A7 CMU08 CAN Timeout, U11A8 CMU09 CAN Timeout, U11A9 CMU10 CAN Timeout, U11AA CMU11 CAN Timeout, U11AB: CMU12 CAN Timeout

TROUBLE JUDGMENT

Check Conditions

- 3 seconds elapse after the electric motor switch is turned ON, or 3 seconds elapse after the Main Drive Lithium-ion Battery starts to be charged.

- The following diagnostic trouble code is not set.
 - a. U1082 Bat-CAN Bus-off

Judgment Criterion

- For more than 3 seconds, the signal cannot be received from one of CMUs through the CAN communication.

FAIL-SAFE AND BACKUP FUNCTION

- Not available

PROBABLE CAUSES

- The module (CMU) in the main drive lithium-ion battery is failed.
- The harnesses and the connectors of the local CAN (for main drive lithium-ion battery) bus.
- Short circuits to ground of CMU power supply circuits; poor contact of connector.
- The BMU is failed.

DIAGNOSIS

STEP 1. Use scan tool MB991958 to confirm a diagnostic trouble code.**Q: Is the diagnostic trouble code set?****YES :** Go to Step 2.**NO :** Intermittent malfunction (Refer to GROUP 00 – How to Use Troubleshooting/Inspection Service Points, How to Cope with Intermittent Malfunctions).

STEP 2. Check CMU12 from CMU01

Check the CMU, which has timed out.

Q: Have all the CMUs been timed out?**YES :** Go to Step 8.**NO :** Check the CMU, which has timed out. Then go to Step 3.

STEP 3. Connector check: C-22, C-26 main drive lithium-ion battery connector, CMU12 from CMU01 connector, resistor (local CAN terminating) connectorRemoval the main drive lithium-ion battery cover (Refer to [P.54D-194](#)).**Q: Is the check result normal?****YES :** Go to Step 4.**NO :** Repair the damaged connector.

STEP 4. Check the wiring harness between C-22 (terminal No. 4) main drive lithium-ion battery connector and CMU12 from CMU01 (each terminal No. 1) connector**NOTE:**

- Before checking harness, check intermediate connector (1) (terminal No. 4, No. 11 from No. 6, No. 22 from No. 15) of out signal line, and repair if necessary.

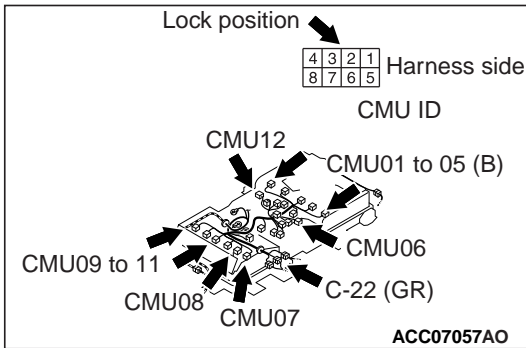

Check power supply line for open circuit.

Q: Is the check result normal?

YES : Go to Step 5.

NO : Repair the wiring harness.

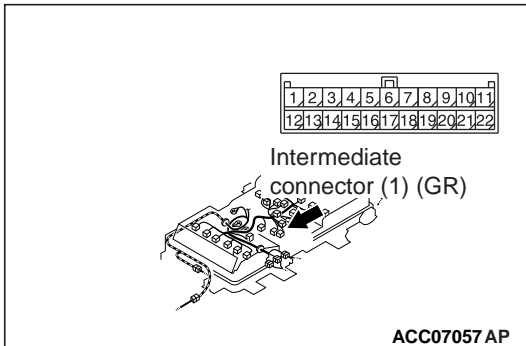

STEP 5. Check the wiring harness between C-26 (terminal No. 5) main drive lithium-ion battery connector and CMU12 from CMU01 (terminal No. 8) connector, resistor (local CAN terminating) (terminal No. 1) connector

NOTE:

- Before checking harness, check intermediate connector (CAN1) (terminal No. 11 from No. 3), intermediate connector (CAN2) (terminal No. 9 from No. 3) of out signal line, and repair if necessary.

Check signal line (CANH) for open circuit.

Q: Is the check result normal?

YES : Go to Step 6.

NO : Repair the wiring harness.

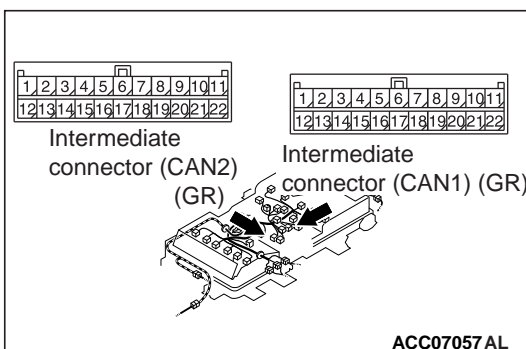
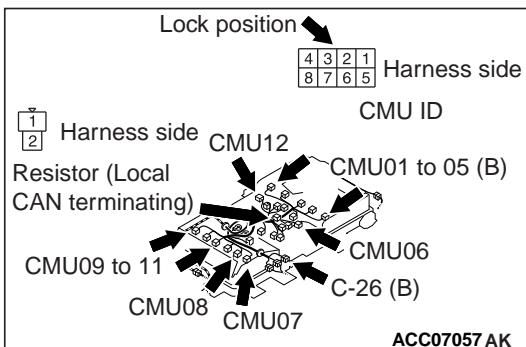

STEP 6. Check the wiring harness between C-26 (terminal No. 10) main drive lithium-ion battery connector and CMU12 from CMU01 (terminal No. 4) connector, resistor (local CAN terminating) (terminal No. 2) connector

NOTE:

- Before checking harness, check intermediate connector (CAN1) terminal No. 22 from No. 14, intermediate connector (CAN2) terminal No. 20 from No. 14 of out signal line, and repair if necessary.

Check signal line (CANL) for open circuit.

Q: Is the check result normal?

YES : Go to Step 7.

NO : Repair the wiring harness.

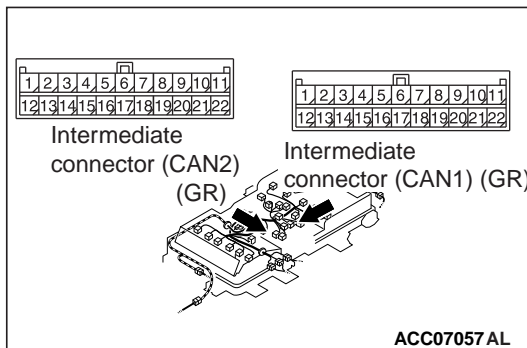
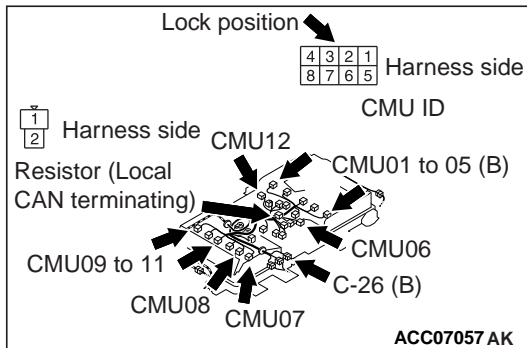

STEP 7. Use scan tool MB991958 to confirm a diagnostic trouble code.

Q: Is the diagnostic trouble code set?

YES : Replace the main drive lithium-ion battery.

NO : Intermittent malfunction (Refer to GROUP 00 – How to Use Troubleshooting/Inspection Service Points, How to Cope with Intermittent Malfunctions).

STEP 8. Check the local CAN (for main drive lithium-ion battery) terminating resistance itself

- (1) Removal the local CAN terminating resistor in main drive lithium-ion battery (Refer to P.54D-189).
- (2) Check the local CAN terminating resistor in main drive lithium-ion battery (Refer to P.54D-217).

Q: Is the check result normal?

YES : Go to Step 13.

NO : Go to Step 9.

STEP 9. Connector check: C-26 main drive lithium-ion battery connector, CMU12 from CMU01 connector, BMU connector, resistor (local CAN terminating) connector
 Removal the main drive lithium-ion battery cover (Refer to P.54D-194).

Q: Is the check result normal?

YES : Go to Step 10.

NO : Repair the damaged connector.

STEP 10. Check the wiring harness between C-26 (terminal No. 5) main drive lithium-ion battery connector and CMU12 from CMU01 (terminal No. 8) connector, BMU (terminal No.24) connector, resistor (local CAN terminating) (terminal No. 1) connector

NOTE:

- Before checking harness, check intermediate connector (CAN1) (terminal No. 11 from No. 3), intermediate connector (CAN2) (terminal No. 9 from No. 2) of out signal line, and repair if necessary.

Check signal line (CANH) for open circuit.

Q: Is the check result normal?

YES : Go to Step 11.

NO : Repair the wiring harness.

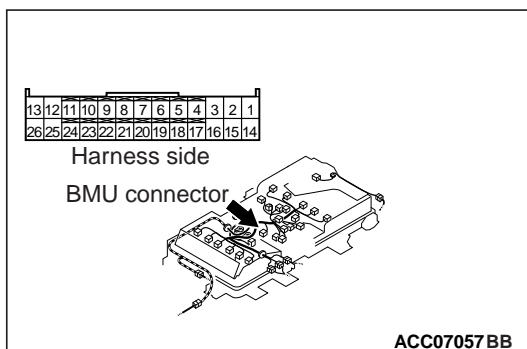
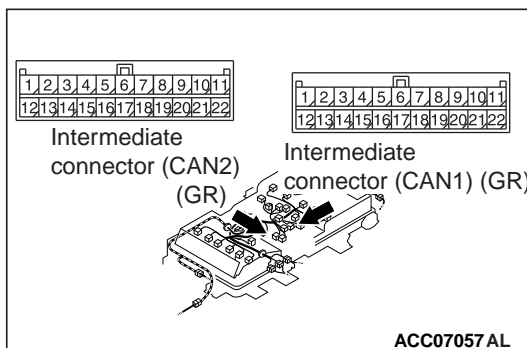
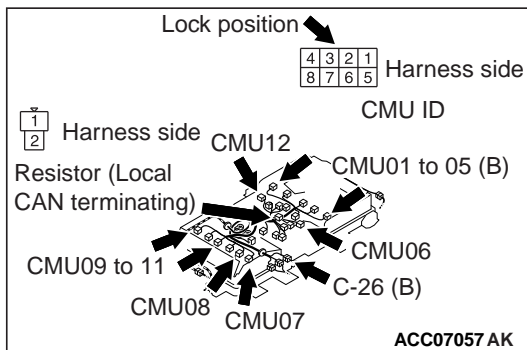

STEP 11. Check the wiring harness between C-26 (terminal No. 10) main drive lithium-ion battery connector and CMU12 from CMU01 (terminal No. 4) connector, BMU (terminal No.23) connector, resistor (local CAN terminating) (terminal No. 2) connector

NOTE:

- Before checking harness, check intermediate connector (CAN1) terminal No. 22 from No. 14, intermediate connector (CAN2) terminal No. 20 from No. 13 of out signal line, and repair if necessary.

Check signal line (CANL) for open circuit.

Q: Is the check result normal?

YES : Go to Step 12.

NO : Repair the wiring harness.

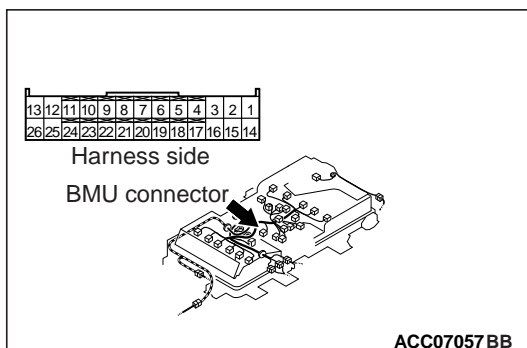
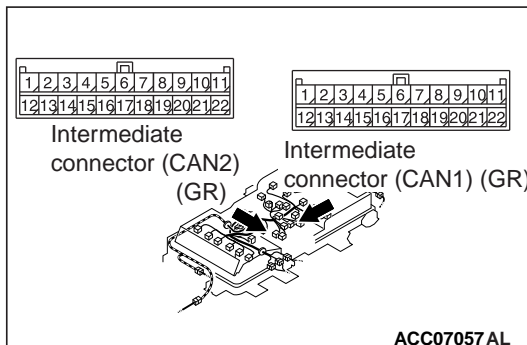
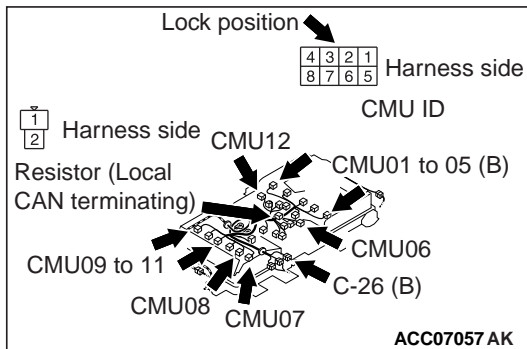

STEP 12. Check the local CAN (for main drive lithium-ion battery) terminating resistor

- (1) Removal the local CAN terminating resistor in main drive lithium-ion battery (Refer to [P.54D-189](#)).
- (2) Check the local CAN terminating resistor in main drive lithium-ion battery (Refer to [P.54D-217](#)).

Q: Is the check result normal?

YES : Go to Step 13.

NO : Replace the local CAN terminating resistor (Refer to [P.54D-209](#)).

STEP 13. Use scan tool MB991958 to confirm a diagnostic trouble code.

Q: Is the diagnostic trouble code set?

YES : Replace the BMU (Refer to [P.54D-188](#)).

NO : Intermittent malfunction (Refer to GROUP 00 – How to Use Troubleshooting/Inspection Service Points, How to Cope with Intermittent Malfunctions).

DTC U1925 CMU ID Numbering Reception Error

TROUBLE JUDGMENT

Check Condition

- When the CMUs are numbered for identification.

Judgment Criterion

- Within 5 seconds after the system has numbered a CMU, the system cannot receive any information pertaining to that identification number from the CMU.
or
- A parity error is detected in communication data.
or
- A checksum error is detected in communication data.

FAIL-SAFE AND BACKUP FUNCTION

- Not available

PROBABLE CAUSES

- The module (CMU) in the main drive lithium-ion battery is failed.
- The harnesses and connectors are failed.
- Short circuits to ground of CMU power supply circuits; poor contact of connector.
- Noise interruption in communication wires.
- The BMU is failed.

DIAGNOSIS

STEP 1. Use scan tool MB991958 to confirm a diagnostic trouble code.

Reconfirm whether the diagnostic trouble codes are set in the BMU.

1. Electric motor switch: LOCK (OFF) → ON
2. Select "BMU" from System Select Screen of the scan tool MB991958.
3. Select "Special Function" from BMU Screen.
4. Select "CMU ID numbering" from Special Function.

Q: Is the diagnostic trouble code set?

YES : Go to Step 2.

NO : Intermittent malfunction (Refer to GROUP 00 – How to Use Troubleshooting/Inspection Service Points, How to Cope with Intermittent Malfunctions).

STEP 2. Connector check: C-21, C-22 main drive lithium-ion battery connector, CMU12 from CMU01 connector, resistor (local CAN terminating) connector

Removal the main drive lithium-ion battery cover (Refer to [P.54D-194](#)).

Q: Is the check result normal?

YES : Go to Step 3.

NO : Repair the damaged connector.

STEP 3. Check the wiring harness between C-22 (terminal No. 4) main drive lithium-ion battery connector and CMU12 from CMU01 connector (each terminal No. 1)**NOTE:**

- Before checking harness, check intermediate connector (1) (terminal No. 4, No. 11 from No. 6, No. 22 from No. 15) of out signal line, and repair if necessary.

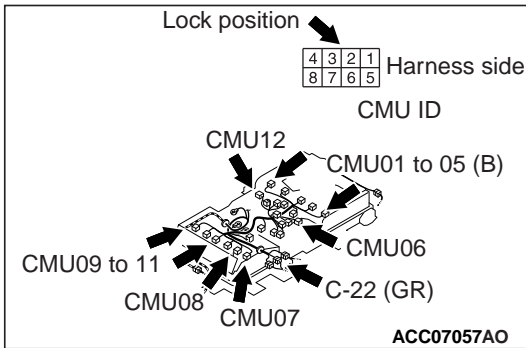

Check power supply line for open circuit.

Q: Is the check result normal?

YES : Go to Step 4.

NO : Repair the wiring harness.

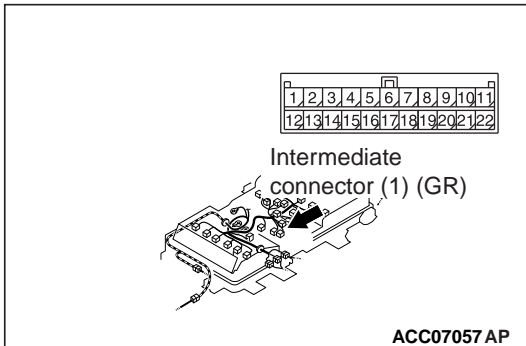

STEP 4. Check the wiring harness between C-21 (terminal No. 3) main drive lithium-ion battery connector and CMU12 from CMU01 connector (each terminal No. 7)

NOTE:

- Before checking harness, check intermediate connector (2) (terminal No. 16 from No. 12, No. 22 from No. 18) or intermediate connector (3) (terminal No. 1, No. 2, No. 10 from No. 6) of ground line, and repair if necessary.

Check ground line for open circuit.

Q: Is the check result normal?

YES : Go to Step 5.

NO : Repair the wiring harness.

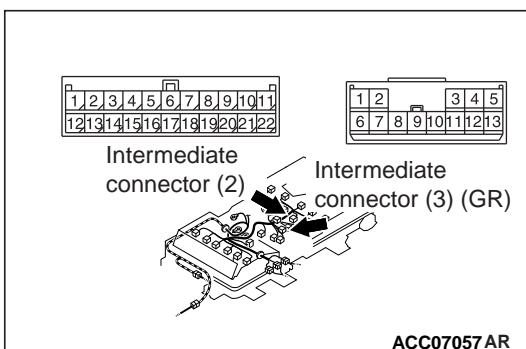
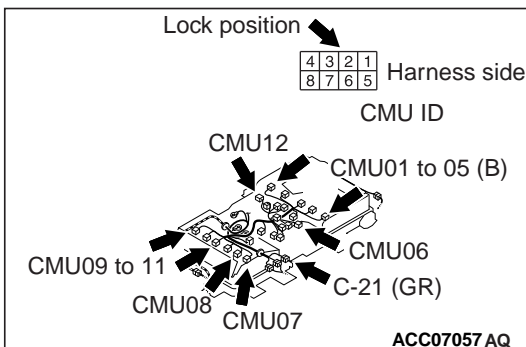

STEP 5. Check the wiring harness between BMU connector (terminal No. 13, 12) and CMU12 from CMU01 connector (each terminal No. 2, 6)

NOTE:

- Check the wiring harness between BMU connector (terminal No. 13) and CMU07 connector (terminal No. 2), CMU07 connector (terminal No. 6) and CMU08 connector (terminal No. 2), CMU08 connector (terminal No. 6) and CMU09 connector (terminal No. 2), CMU09 connector (terminal No. 6) and CMU10 connector (terminal No. 2), CMU10 connector (terminal No. 6) and CMU11 connector (terminal No. 2), CMU11 connector (terminal No. 6) and CMU12 connector (terminal No. 2), CMU12 connector (terminal No. 6) and CMU01 connector (terminal No. 2), CMU01 connector (terminal No. 6) and CMU02 connector (terminal No. 2), CMU02 connector (terminal No. 6) and CMU03 connector (terminal No. 2), CMU03 connector (terminal No. 6) and CMU04 connector (terminal No. 2), CMU04 connector (terminal No. 6) and CMU05 connector (terminal No. 2), CMU05 connector (terminal No. 6) and CMU06 connector (terminal No. 2), CMU06 connector (terminal No. 6) and BMU connector (terminal No. 12), and repair if necessary.

Check signal line for open circuit.

Q: Is the check result normal?

YES : Go to Step 6.

NO : Repair the wiring harness.

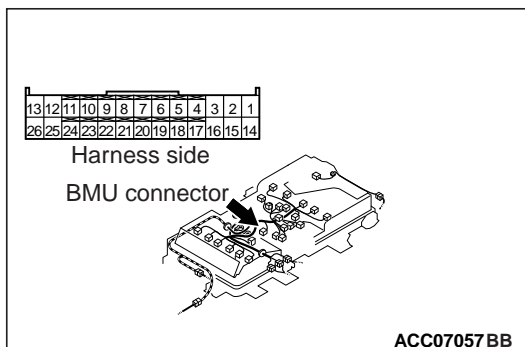
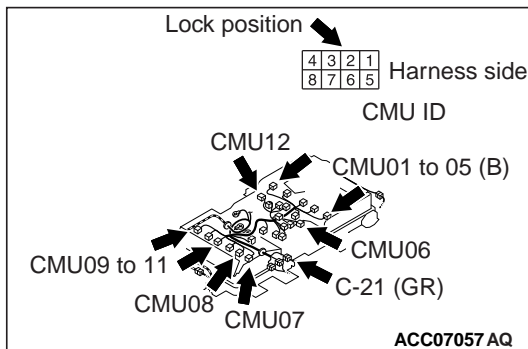

STEP 6. Use scan tool MB991958 to confirm a diagnostic trouble code.

Reconfirm whether the diagnostic trouble codes are set in the BMU.

1. Erase the diagnostic trouble codes being set.
2. Electric motor switch: LOCK (OFF) → ON
3. Confirm whether the diagnostic trouble codes are set.

Q: Is the diagnostic trouble code set?

YES : Replace the BMU (Refer to [P.54D-188](#)).

NO : Intermittent malfunction (Refer to GROUP 00 – How to Use Troubleshooting/Inspection Service Points, How to Cope with Intermittent Malfunctions).

DTC U1926 EV-ECU V-CAN Error

TROUBLE JUDGMENT

Check Condition

- 3 seconds elapse after the electric motor switch is turned ON, or 3 seconds elapse after the main drive lithium-ion battery starts to be charged.

Judgment Criterion

- When one of the following diagnostic trouble codes is set in the EV-ECU.
 - a. U1073 Bus-off
 - b. U111C BMU CAN Timeout

FAIL-SAFE AND BACKUP FUNCTION

- When the K-LINE is normal, use the K-LINE communication data.

PROBABLE CAUSES

- The EV-ECU is failed.
- The harnesses and the connectors of the CAN bus are failed.
- The BMU is failed.

DIAGNOSIS

STEP 1. Scan tool MB991958 CAN bus diagnosis

- Using scan tool MB991958, perform CAN bus line diagnosis.

Q: Is the check result normal?

YES : Go to Step 2.

NO : Repair CAN bus line (Refer to GROUP 54C – Troubleshooting – CAN Bus Diagnostics Table). After repairing CAN bus line, go to Step 4.

STEP 2. Scan tool MB991958 other system diagnostic trouble code.

- Confirm whether the diagnostic trouble codes are set in the EV-ECU.

Q: Is the diagnostic trouble code set?

YES : Perform the troubleshooting of the EV-ECU.

NO : Go to Step 3.

STEP 3. Use scan tool MB991958 to confirm a diagnostic trouble code.

Reconfirm whether the diagnostic trouble codes are set in the BMU.

1. Erase the diagnostic trouble codes being set.
2. Electric motor switch: LOCK (OFF) → ON
3. Confirm whether the diagnostic trouble codes are set.

Q: Is the diagnostic trouble code set?

YES : Replace the BMU (Refer to [P.54D-188](#)). Then go to Step 4.

NO : Intermittent malfunction (Refer to GROUP 00 – How to Use Troubleshooting/Inspection Service Points, How to Cope with Intermittent Malfunctions).

STEP 4. Use scan tool MB991958 to confirm a diagnostic trouble code.

Reconfirm whether the diagnostic trouble codes are set in the BMU.

1. Erase the diagnostic trouble codes being set.
2. Electric motor switch: LOCK (OFF) → ON
3. Confirm whether the diagnostic trouble codes are set.

Q: Is the diagnostic trouble code set?

YES : Go to Step 1.

NO : Check end.

ON-VEHICLE SERVICE

CHECK ON COIL RESISTANCE OF CONTACTOR (for main drive lithium-ion battery)

M1549402100225

⚠ DANGER

- *When high voltage system components are serviced, be sure to remove service plug to shut down high voltage (Refer to GROUP 00 – Precautions before service, Precautions on how to use the high-voltage vehicle).*
- *When removing service plug, wear the specified protective equipment.*

CHECK ON COIL RESISTANCE OF CHARGING CONTACTOR

1. Disconnect the main drive lithium-ion battery connector "A" and "B".

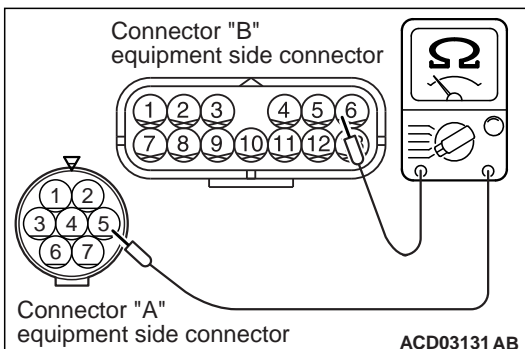
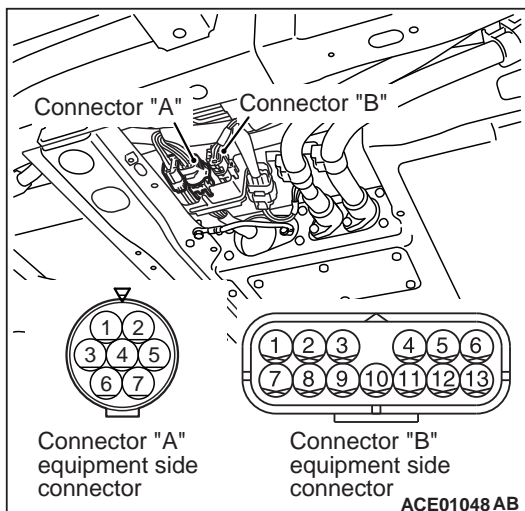

2. Measure the resistance between terminal No.5 of the main drive lithium-ion battery connector "A" and No.6 of the main drive lithium-ion battery connector "B".

Standard value: 36 Ω [at 23°C (73°F)]

3. If the resistance deviates from the standard value, replace charging contactor (Refer to P.54D-191).

CHECKING COIL RESITANCE OF QUICK CHARGING CONTACTOR (+)

1. Disconnect the main drive lithium-ion battery connector "A" and "B".

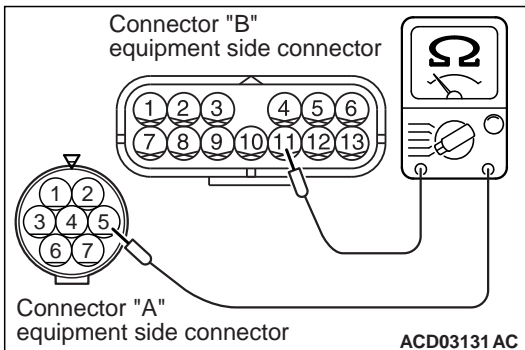
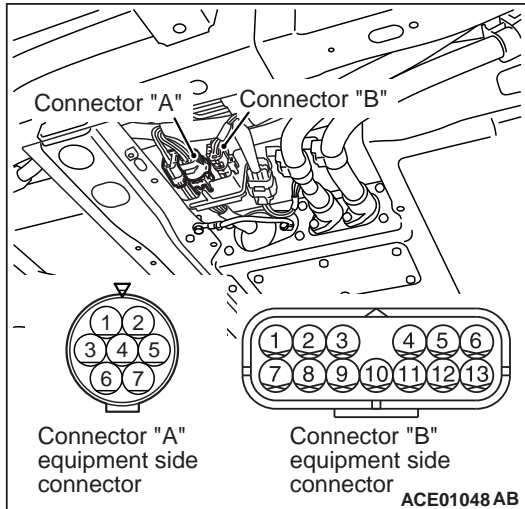

2. Measure the resistance between terminal No.5 of the main drive lithium-ion battery connector "A" and No.11 of the main drive lithium-ion battery connector "B".

Standard value: 36 Ω [at 23°C (73°F)]

3. If the resistance deviates from the standard value, replace quick charging contactor (+) (Refer to P.54D-191).

CHECKING COIL RESITANCE OF QUICK CHARGING CONTACTOR (-)

1. Disconnect the main drive lithium-ion battery connector "A" and "B".

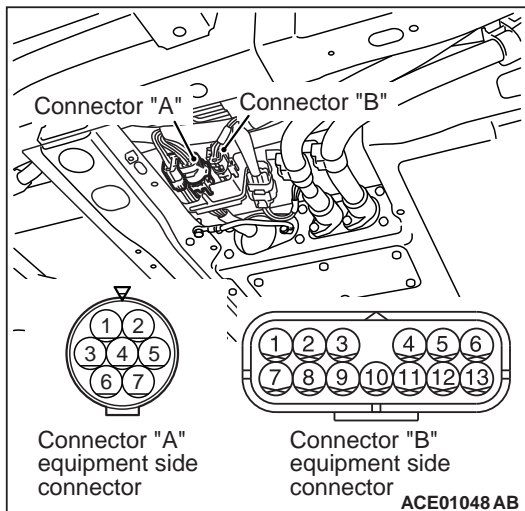

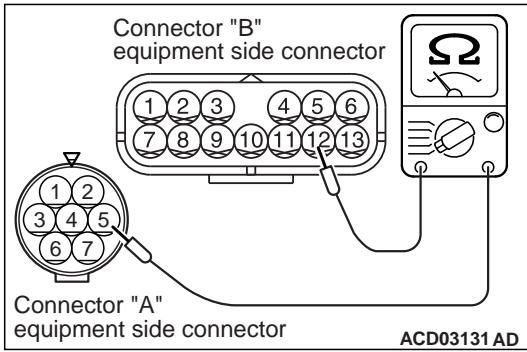

2. Measure the resistance between terminal No.5 of the main drive lithium-ion battery connector "A" and No.12 of the main drive lithium-ion battery connector "B".

Standard value: 36 Ω [at 23°C (73°F)]

3. If the resistance deviates from the standard value, replace quick charging contactor (-) (Refer to [P.54D-191](#)).

CHECK ON COIL RESISTANCE OF MAIN CONTACTOR (+)

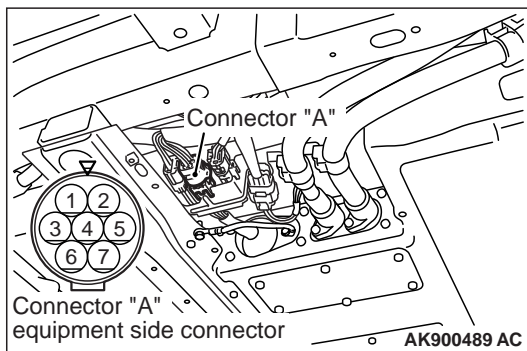

1. Disconnect the main drive lithium-ion battery connector "A".

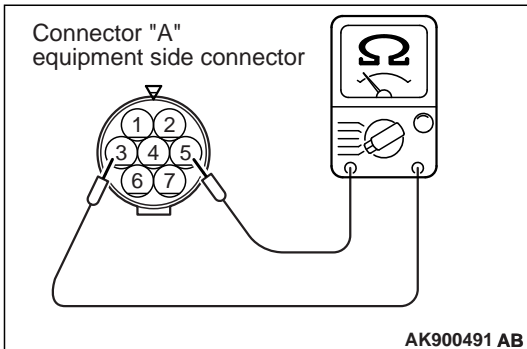

2. Measure the resistance between terminal No. 3 and No. 5 of the main drive lithium-ion battery connector "A".

Standard value: 36 Ω [at 23°C (73°F)]

3. If the resistance deviates from the standard value, replace main contactor (+) (Refer to [P.54D-191](#)).

CHECK ON COIL RESISTANCE OF MAIN CONTACTOR (-)

1. Disconnect the main drive lithium-ion battery connector "A" and "B".

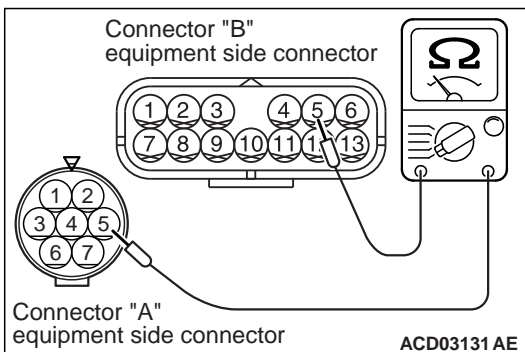
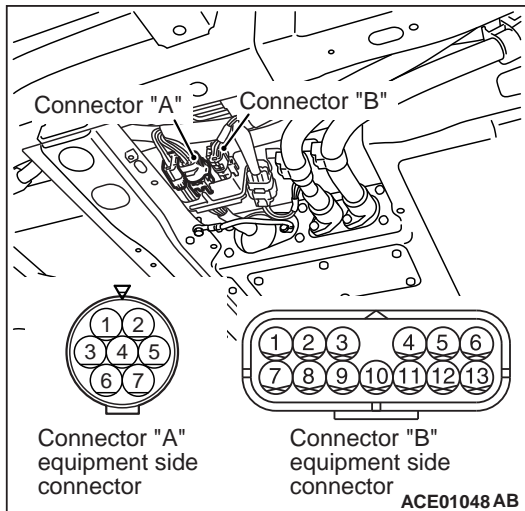

2. Measure the resistance between terminal No.5 of the main drive lithium-ion battery connector "A" and No.5 of the main drive lithium-ion battery connector "B".

Standard value: 36 Ω [at 23°C (73°F)]

3. If the resistance deviates from the standard value, replace main contactor (-) (Refer to P.54D-191).

CHECK ON SERVICE PLUG SWITCH

M1549402400215

1. Disconnect the connector "A" and the connector "B" of the main drive lithium-ion battery.

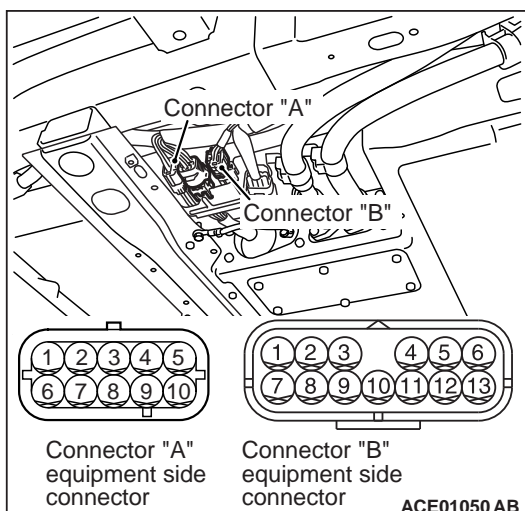

⚠ DANGER

When removing service plug, wear the specified protective equipment (Refer to GROUP 00 – Precautions before service, Precautions on how to use the high-voltage vehicle).

2. Measure the resistance between the main drive lithium-ion battery connector "A" terminal No. 3 and the main drive lithium-ion battery connector "B" terminal No. 4.

Service plug status	Normal condition
Locked service plug	Continuity (2 Ω or less)
Disconnected service plug	No continuity

3. If the resistance deviates from the standard value, replace service plug (Refer to P.54D-191).

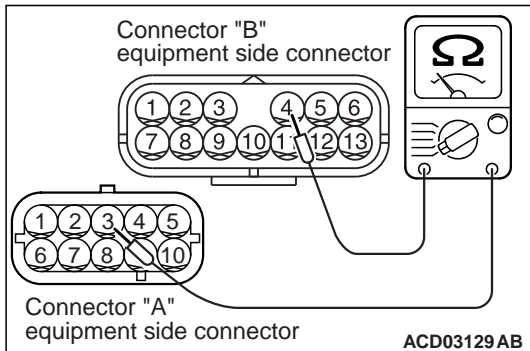

Local CAN (for main drive lithium-ion battery) terminating resistance check

M1549402500223

1. Disconnect the main drive lithium-ion battery connector "A".

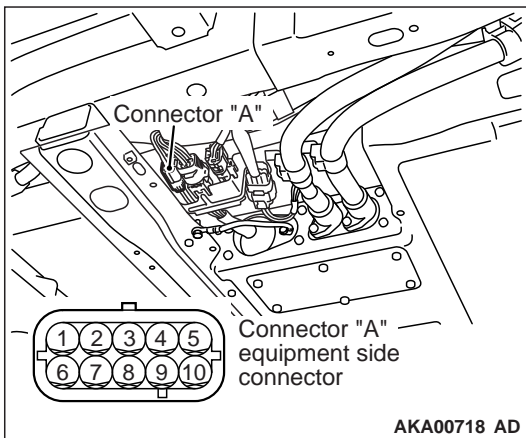

2. Measure the resistance between terminal No. 5 and No. 10 of main drive lithium-ion battery connector "A".

Standard value: 44 – 57 Ω [at 20°C (68°F)]

3. If the resistance deviates from the standard value, troubleshoot the BMU or replace BMU (P.54D-188), local CAN terminating resistor in main drive lithium-ion battery.

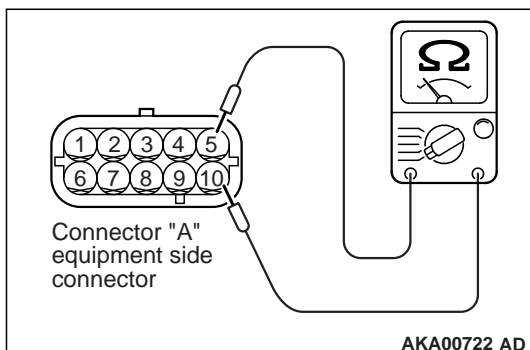

CHECK AND REPLACEMENT OF THE HIGH-VOLTAGE FUSE INSIDE THE MAIN DRIVE LITHIUM-ION BATTERY

M1549403000209

⚠ DANGER

When servicing the high-voltage system parts, be sure to wear the specified protection equipment and disconnect the service plug to interrupt the high-voltage supply (Refer to GROUP 00 – Precautions before service, Precautions on how to use the high-voltage vehicle).

1. Remove the front floor covers A and B (Refer to GROUP 51 – Under Cover).
2. Remove the work hole lid for the main drive lithium-ion battery.

⚠ CAUTION

To pull out high-voltage fuse No. 3 (heater, 50A), wedge the ornament remover (special tool: MB990784) into the JFB ribs to counterhold the fuse.

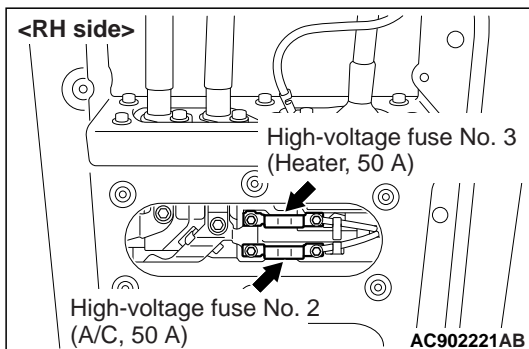
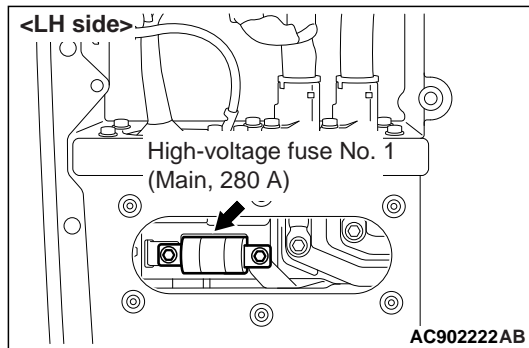
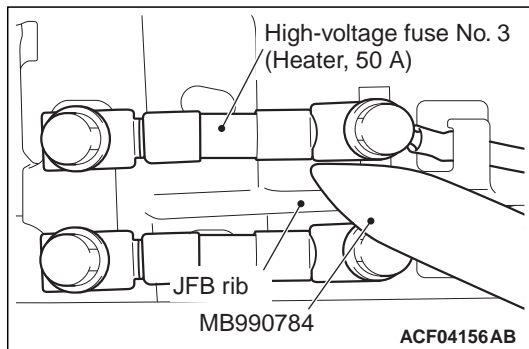

3. Remove each mounting bolt and remove each high-voltage fuse.
4. check the resistance between the high-voltage fuses, and if there is no continuity (open circuit), replace the high-voltage fuses.

⚠ CAUTION

When tightening the mounting bolts, secure the high-voltage fuse terminal portion, because there is a risk of damage to the high-voltage fuse when an excessive force applies to the high-voltage fuse main body.

5. Tighten each mounting bolt to the specified torque. Tighten each mounting bolt for the high-voltage fuse No. 2 and 3 to the specified torque using the torque wrench (special tool: MB992295).

Tightening torque:

High-voltage fuse No. 1: 9.0 ± 3.0 N·m (80 ± 26 in-lb)

High-voltage fuse No. 2 and 3: 7.0 ± 3.0 N·m (62 ± 26 in-lb)

6. Install the work hole lid for the main drive lithium-ion battery.
7. Install the front floor covers A and B (Refer to GROUP 51 – Under Cover).

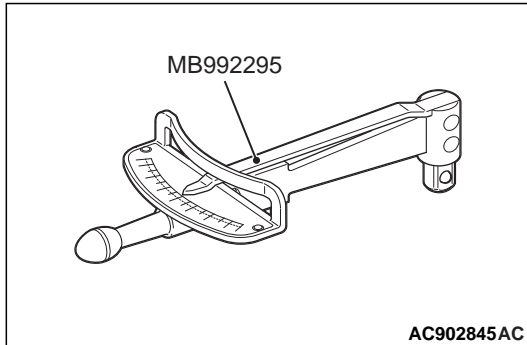

BATTERY MANAGEMENT UNIT (BMU)**REMOVAL AND INSTALLATION**

M1549401200081

⚠ DANGER

- *When high voltage system components are serviced, be sure to remove service plug to shut down high voltage (Refer to GROUP 00 – Precautions before service, Precautions on how to use the high-voltage vehicle).*
- *Do not disassemble any battery management unit (BMU) other than those described in this manual.*

⚠ CAUTION

- When replacing the battery management unit (BMU), use the M.U.T.-III to perform the learned value writing (Refer to GROUP 00 – Procedures for Writing BMU Learning Value).
- While the special tool (MB992924) is set, the vehicle can not be driven to avoid an accident. If you attempt to drive the vehicle, the vehicle will vibrate due to a torque "hunting".

Pre-removal operation

- Main Drive Lithium-ion Battery Cover Removal (Refer to [P.54D-194](#))

Post-installation operation

- Main Drive Lithium-ion Battery Cover Installation (Refer to [P.54D-194](#))

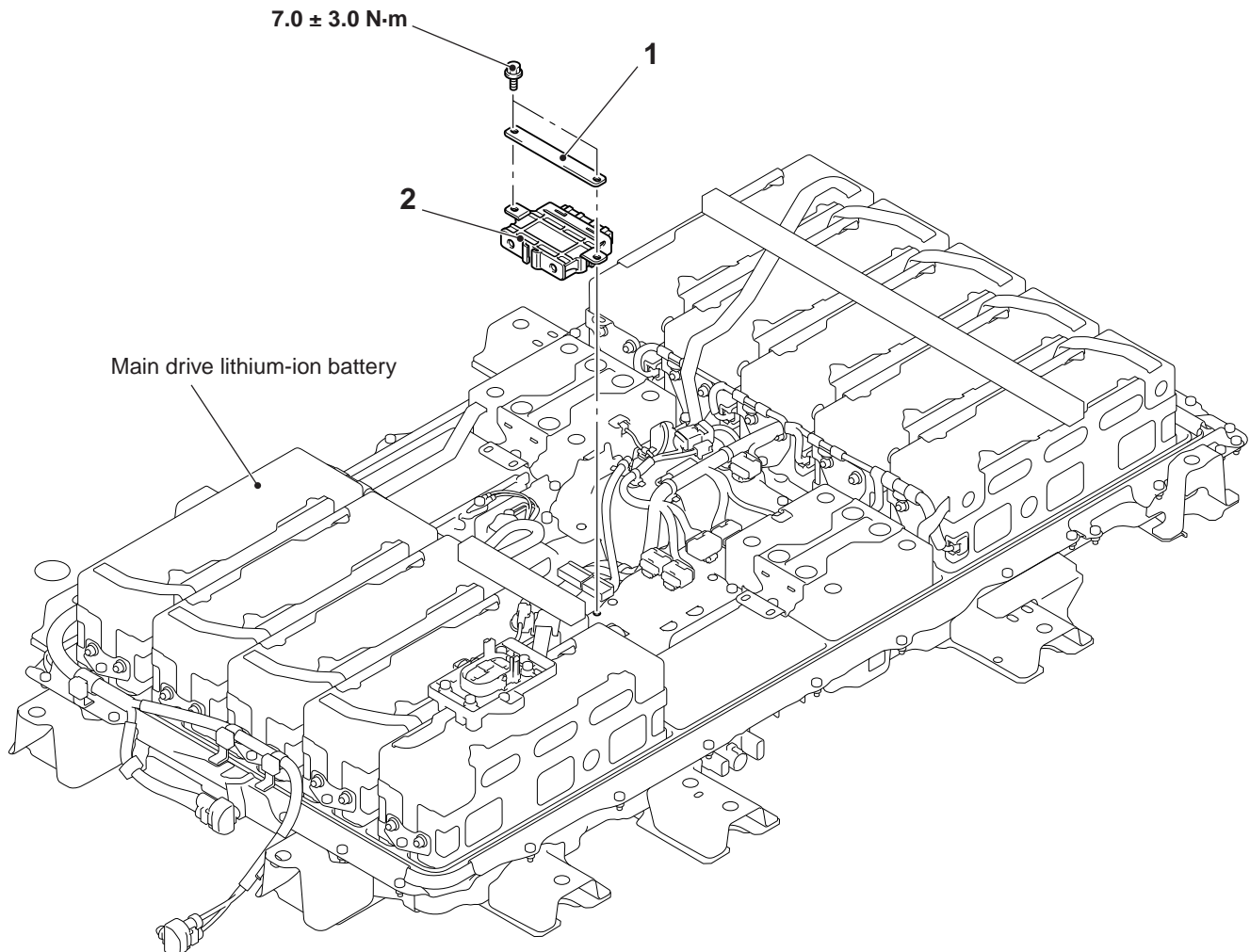

Removal steps

1. BMU reinforcement
2. Battery management unit (BMU)

<<A>>

REMOVAL SERVICE POINT

<<A>> **BATTERY MANAGEMENT UNIT (BMU) REMOVAL**

Ensure that the weld nuts do not fall down from the JFB.

MAIN DRIVE LITHIUM-ION BATTERY DISASSEMBLY AND ASSEMBLY

SERVICE PROCEDURE

M1549403800120

CAUTION

- When you assemble and disassemble the main drive lithium-ion battery, always wear electric-insulated gloves, boots and protection glasses.
- After you remove the main drive lithium-ion battery, be sure to disconnect all of the four bus bars from the front and rear modules to reduce the possibility of electric shock. Do not connect the bus bars until you complete the service work.
- Use special tool (MB992915) to protect the unaffected area (which you do not service) of the removed main drive lithium-ion battery.
- When you service an electric terminal on the module, remove the respective cover only (do not remove the other covers).
- Before engaging the bus bar, make sure that it is not scratched or contaminated.
- A damaged wiring harness clip should be replaced with new one.
- Always use a torque wrench to tighten a nut or bolt to the specified torque. Then identify it with a paint mark.

ium-ion battery capacity without mounting the main drive lithium-ion battery.

After assembling the main drive lithium-ion battery, check the followings:

1. Before mounting the main drive lithium-ion battery to the vehicle, check the main drive lithium-ion battery for air leaks (Refer to [P.54D-211](#)).
2. When any of the cell modules is replaced, use the M.U.T.-III to select and execute "CMU ID numbering" on the BMU special function menu to number the CMUs for identification after the main drive lithium-ion battery assembly has been mounted. Then measure the main drive lithium-ion battery capacity.
3. Use the scan tool MB991958 to check that no diagnostic trouble code is stored.

*NOTE: * : Using the recommended tools allows you to number the CMU and measure the main drive lith-*

EIGHT-CELL MODULE REMOVAL AND INSTALLATION

Service procedure	Work description	Reference page
1	Main drive lithium-ion battery cover removal and installation	P.54D-194
2	Air duct removal and installation	P.54D-196
3	Pad removal and installation	P.54D-196
4	Bus bar removal and installation	P.54D-197
5	Eight-cell module removal and installation	P.54D-198

FOUR-CELL MODULE REMOVAL AND INSTALLATION

Service procedure	Work description	Reference page
1	Main drive lithium-ion battery cover removal and installation	P.54D-194
2	Air duct removal and installation	P.54D-196
3	Pad removal and installation	P.54D-196
4	Bus bar removal and installation	P.54D-197
5	JFB cover removal and installation	P.54D-202
6	Four-cell module removal and installation	P.54D-203

ELECTRIC CURRENT SENSOR REMOVAL AND INSTALLATION

Service procedure	Work description	Reference page
1	Main drive lithium-ion battery cover removal and installation	P.54D-194
2	Air duct removal and installation	P.54D-196
3	Pad removal and installation	P.54D-196
4	Bus bar removal and installation	P.54D-197
5	JFB cover removal and installation	P.54D-202
6	Electric current sensor removal and installation	P.54D-207

RESISTOR REMOVAL AND INSTALLATION

Service procedure	Work description	Reference page
1	Main drive lithium-ion battery cover removal and installation	P.54D-194
2	Air duct removal and installation	P.54D-196
3	Pad removal and installation	P.54D-196
4	Bus bar removal and installation	P.54D-197
5	JFB cover removal and installation	P.54D-202
6	JFB removal and installation	P.54D-207
7	Resistor removal and installation	P.54D-209

CONTACTOR REMOVAL AND INSTALLATION

Service procedure	Work description	Reference page
1	Main drive lithium-ion battery cover removal and installation	P.54D-194
2	Air duct removal and installation	P.54D-196
3	Pad removal and installation	P.54D-196
4	Bus bar removal and installation	P.54D-197
5	Battery management unit (BMU) removal and installation	P.54D-188
6	JFB cover removal and installation	P.54D-202
7	JFB removal and installation	P.54D-207
8	Electric current sensor removal and installation	P.54D-207
9	Resistor removal and installation	P.54D-209
10	Contactora removal and installation	P.54D-210

COOLING FAN REMOVAL AND INSTALLATION

Service procedure	Work description	Reference page
1	Main drive lithium-ion battery cover removal and installation	P.54D-194
2	Cooling fan removal and installation	P.54D-211

SERVICE PLUG REMOVAL AND INSTALLATION

Service procedure	Work description	Reference page
1	Main drive lithium-ion battery cover removal and installation	P.54D-194
2	Air duct removal and installation	P.54D-196
3	Pad removal and installation	P.54D-196
4	Bus bar (service plug) removal and installation	P.54D-197

SERVICE PROCEDURE CHECK SHEET

M1549403900105

CAUTION

- When you assemble and disassemble the main drive lithium-ion battery, always wear electric-insulated gloves, boots and protection glasses.
- After you remove the main drive lithium-ion battery, be sure to disconnect all of the four bus bars from the front and rear modules to reduce the possibility of electric shock. Do not connect the bus bars until you complete the service work.
- Use special tool (MB992915) to protect the unaffected area (which you do not service) of the removed main drive lithium-ion battery.
- When you service an electric terminal on the

module, remove the respective cover **ONLY** (do not remove the other covers).

- Before engaging the bus bar, make sure that it is not scratched or contaminated.
- A damaged wiring harness clip should be replaced with new one.
- Always use a torque wrench to tighten a nut or bolt to the specified torque. Then identify it with a paint mark.

ITEMS TO CHECK AFTER THE MAIN DRIVE LITHIUM-ION BATTERY HAS BEEN ASSEMBLED

Check column	Service procedure	Work description
	1	Check the battery assembly for air leaks.
	2	Use the scan tool MB991958 to number the CMUs for identification.
	3	Measure the main drive lithium-ion battery capacity.
	4	Use the scan tool MB991958 to check that no diagnostic trouble code is stored.

EIGHT-CELL MODULE REMOVAL AND INSTALLATION

Check column	Service procedure	Work description
	1	Main drive lithium-ion battery cover removal and installation
	2	Air duct removal and installation
	3	Pad removal and installation
	4	Bus bar removal and installation
	5	Eight-cell module removal and installation

FOUR-CELL MODULE REMOVAL AND INSTALLATION

Check column	Service procedure	Work description
	1	Main drive lithium-ion battery cover removal and installation
	2	Air duct removal and installation
	3	Pad removal and installation
	4	Bus bar removal and installation
	5	JFB cover removal and installation
	6	Four-cell module removal and installation

ELECTRIC CURRENT SENSOR REMOVAL AND INSTALLATION

Check column	Service procedure	Work description
	1	Main drive lithium-ion battery cover removal and installation
	2	Air duct removal and installation
	3	Pad removal and installation
	4	Bus bar removal and installation
	5	JFB cover removal and installation
	6	Electric current sensor removal and installation

RESISTOR REMOVAL AND INSTALLATION

Check column	Service procedure	Work description
	1	Main drive lithium-ion battery cover removal and installation

Check column	Service procedure	Work description
	2	Air duct removal and installation
	3	Pad removal and installation
	4	Bus bar removal and installation
	5	JFB cover removal and installation
	6	JFB removal and installation
	7	Resistor removal and installation

CONTACTOR REMOVAL AND INSTALLATION

Check column	Service procedure	Work description
	1	Main drive lithium-ion battery cover removal and installation
	2	Air duct removal and installation
	3	Pad removal and installation
	4	Bus bar removal and installation
	5	Battery management unit (BMU) removal and installation
	6	JFB cover removal and installation
	7	JFB removal and installation
	8	Electric current sensor removal and installation
	9	Resistor removal and installation
	10	Contactor removal and installation

COOLING FAN REMOVAL AND INSTALLATION

Check column	Service procedure	Work description
	1	Main drive lithium-ion battery cover removal and installation
	2	Cooling fan removal and installation

SERVICE PLUG REMOVAL AND INSTALLATION

Check column	Service procedure	Work description
	1	Main drive lithium-ion battery cover removal and installation
	2	Air duct removal and installation
	3	Pad removal and installation
	4	Bus bar (service plug) removal and installation

MAIN DRIVE LITHIUM-ION BATTERY COVER REMOVAL AND INSTALLATION

M1549404000075

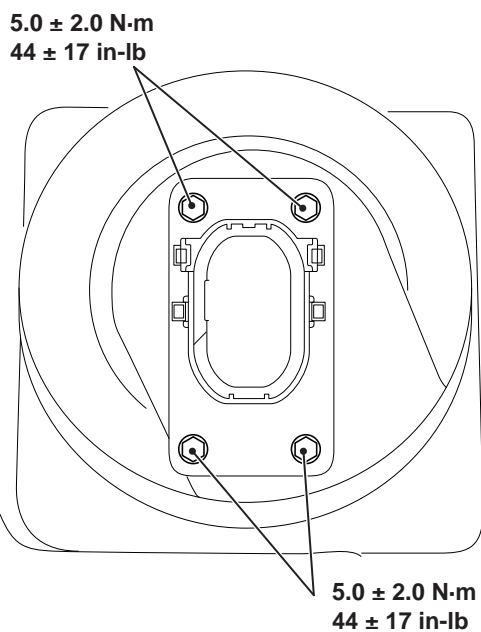

ACC05936AC

1. Remove the four fasteners securing the service plug base to the main drive lithium-ion battery cover.

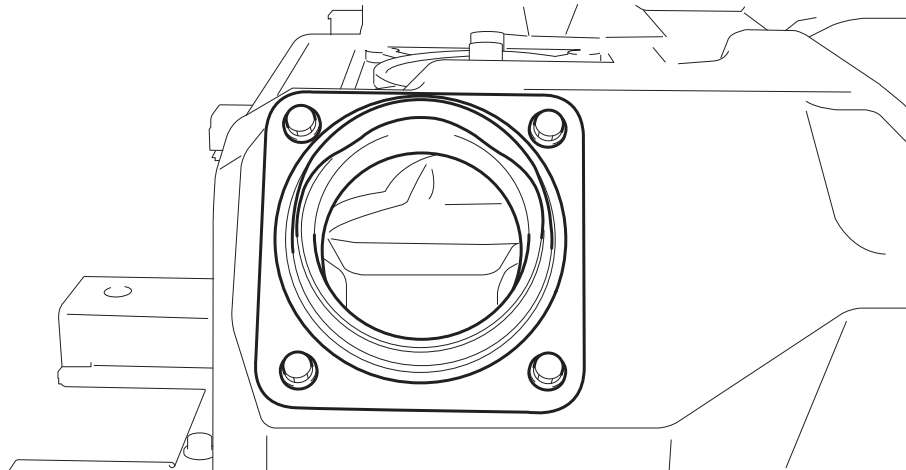

ACC07225

2. Remove the four fasteners to remove the cooling duct. <Vehicles with main drive lithium-ion battery warming system or quick-charging system>

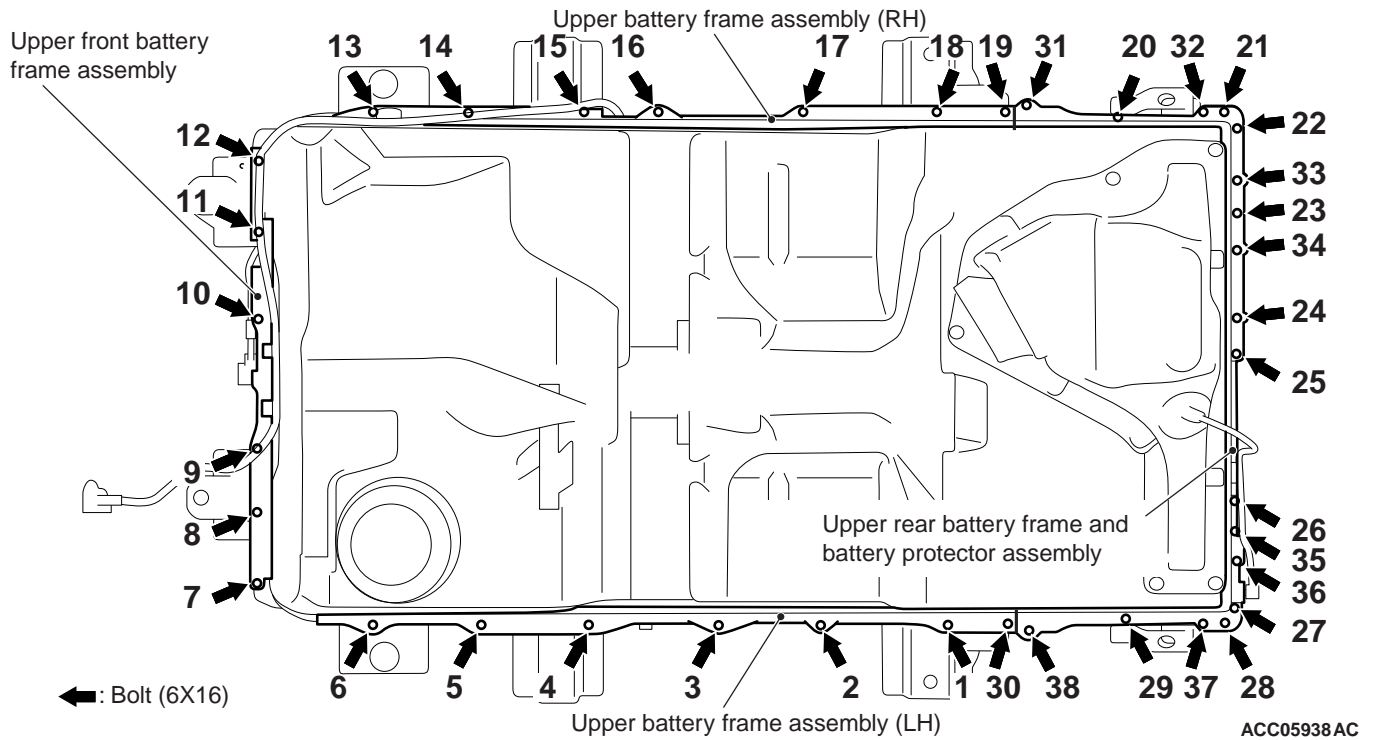

- Remove the 38 fasteners securing the main drive lithium-ion battery cover to the main drive lithium-ion battery tray.

NOTE: Tighten the 38 fasteners securing the main drive lithium-ion battery cover to the main drive lithium-ion battery tray in the order shown.

Tightening torque:

10 ± 2 N·m (89 ± 17 in·lb)

- Remove the frame or protector securing the main drive lithium-ion battery cover to the main drive lithium-ion battery tray.

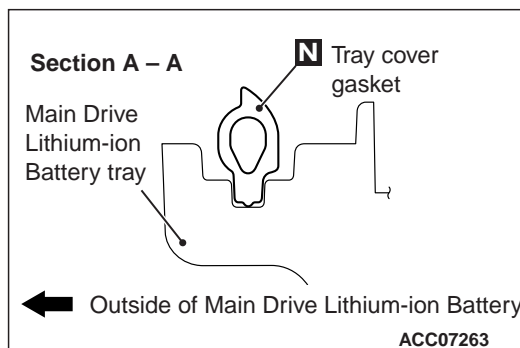
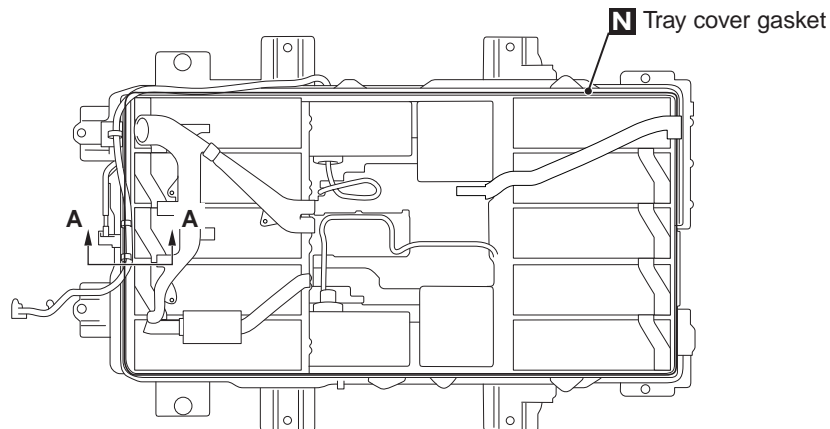

5. Remove the cover of the main drive lithium-ion battery.

NOTE: Make sure that the tray cover gasket is located between the main drive lithium-ion battery cover and the main drive lithium-ion battery tray as shown.

AIR DUCT REMOVAL AND INSTALLATION

M1549404100016

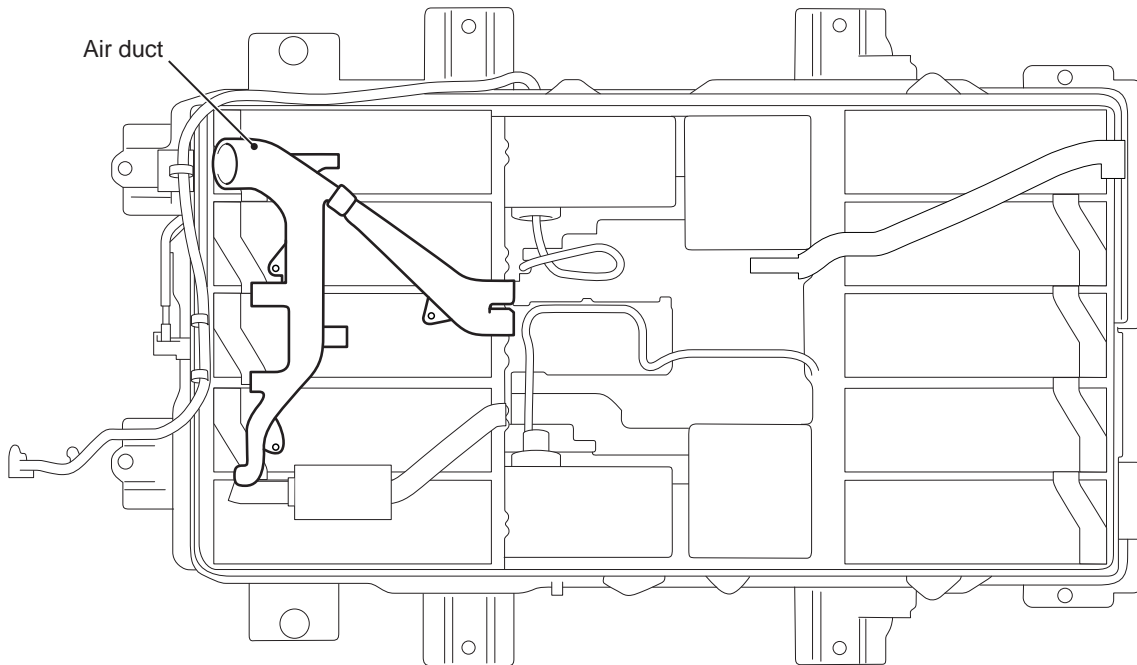

ACC05940AC

1. Remove the three mounting fasteners from the air duct. 2. Remove the air duct.

PAD REMOVAL AND INSTALLATION

M1549404200013

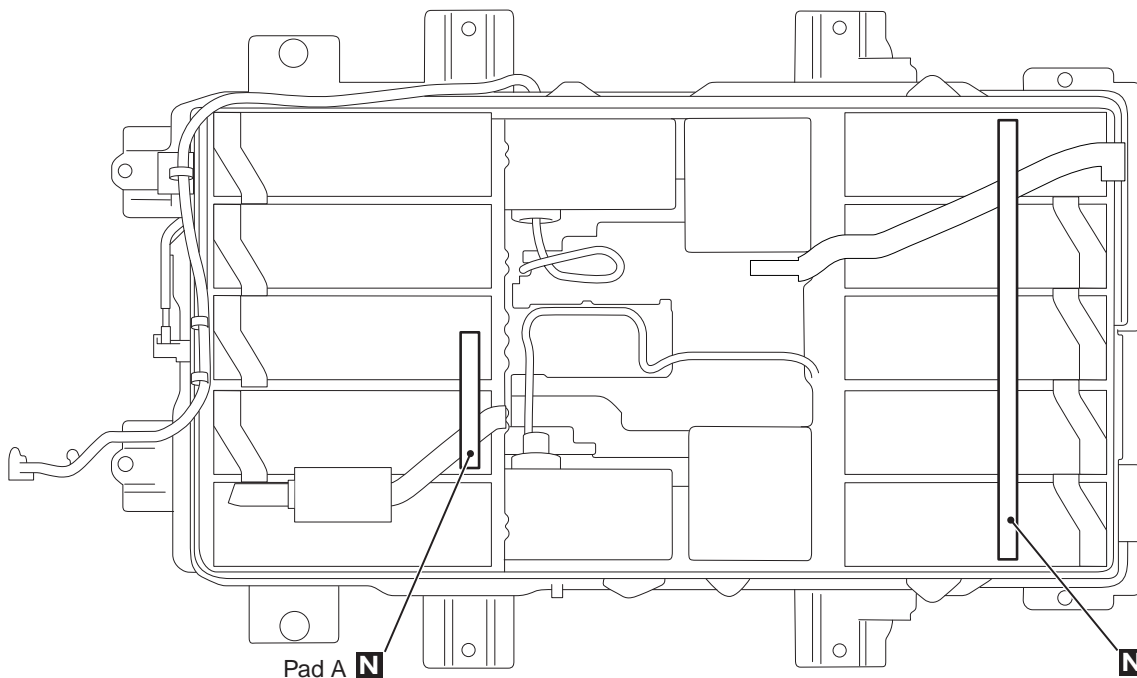

ACD02690AB

Remove the pad.

Number of pads:
 A and B

BUS BAR REMOVAL AND INSTALLATION

M1549404300054

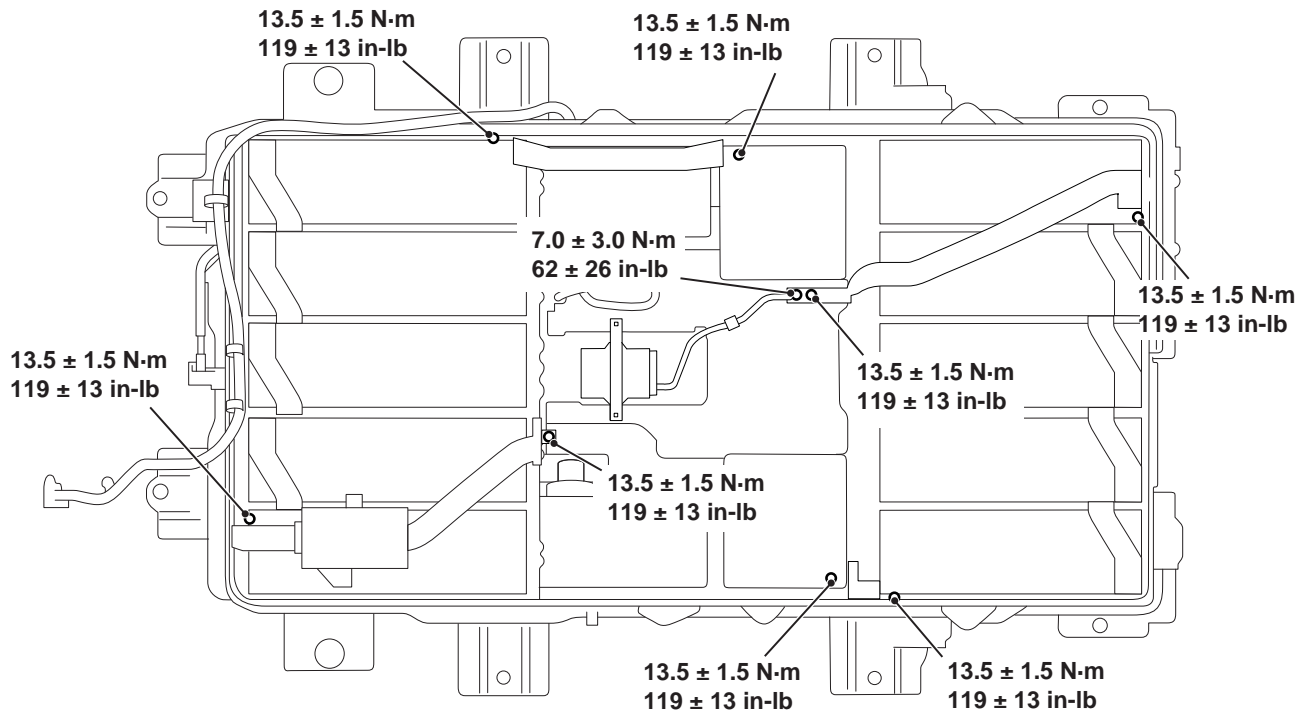

ACE01062 AB

1. Disconnect the bus bar from the module (nine locations) and loosen it (two locations).

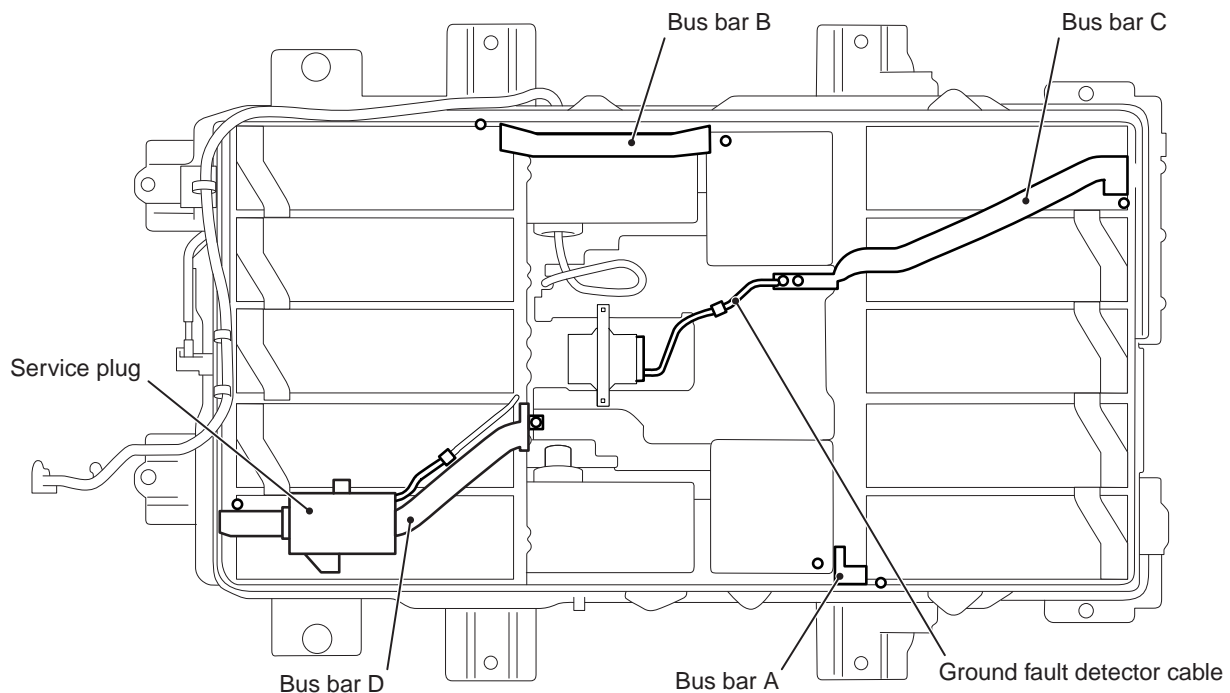

ACF02331 AB

CAUTION

Before installing the bus bar shown by "A" in the figure, use a multimeter to check that there is no potential difference between the two module

terminals at the bus bar ends.

2. Remove the four bus bars in the alphabetical order shown.

EIGHT-CELL MODULE REMOVAL AND INSTALLATION

M1549404400062

NOTE:

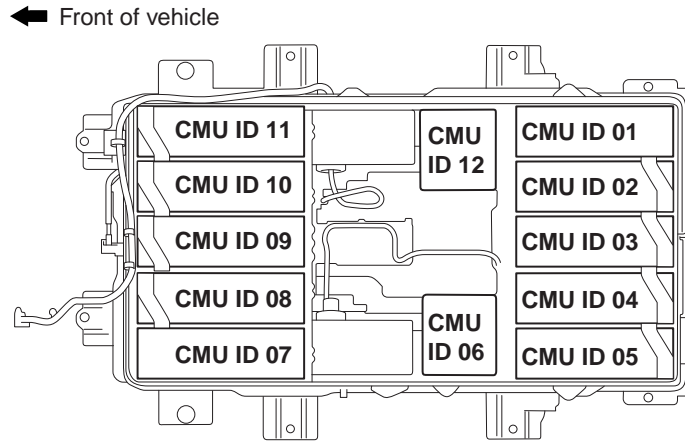

ACC07060 AC

The CMU IDs on the module are assigned as shown.

CAUTION

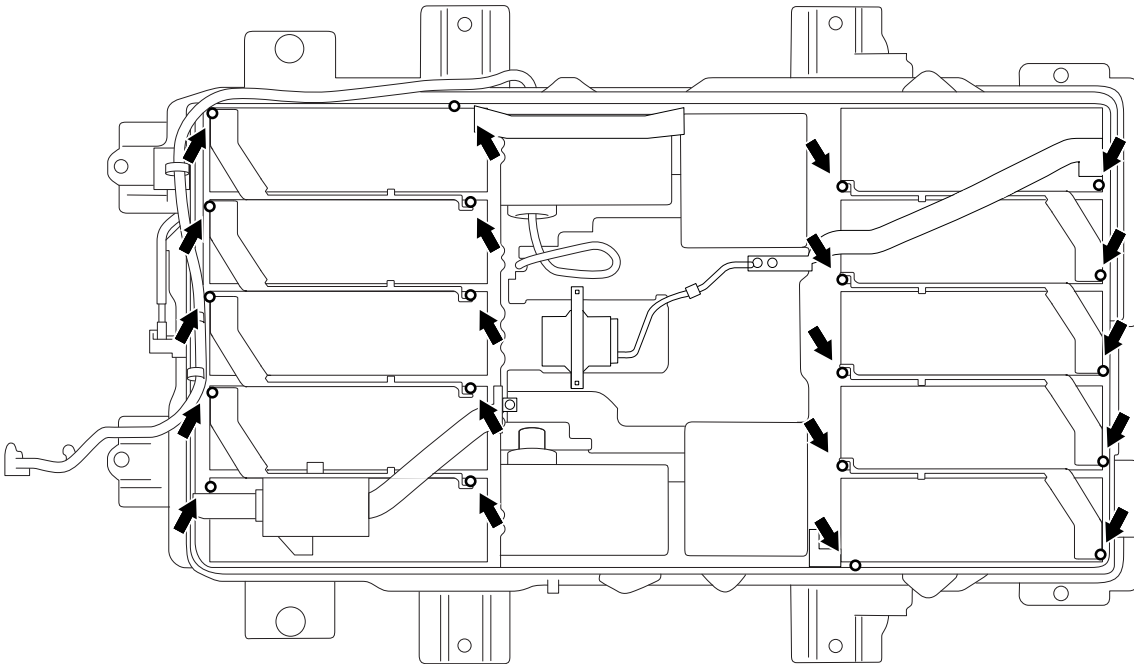

ACE03021 AC

Use a straight wrench as the clearances among the modules are small.

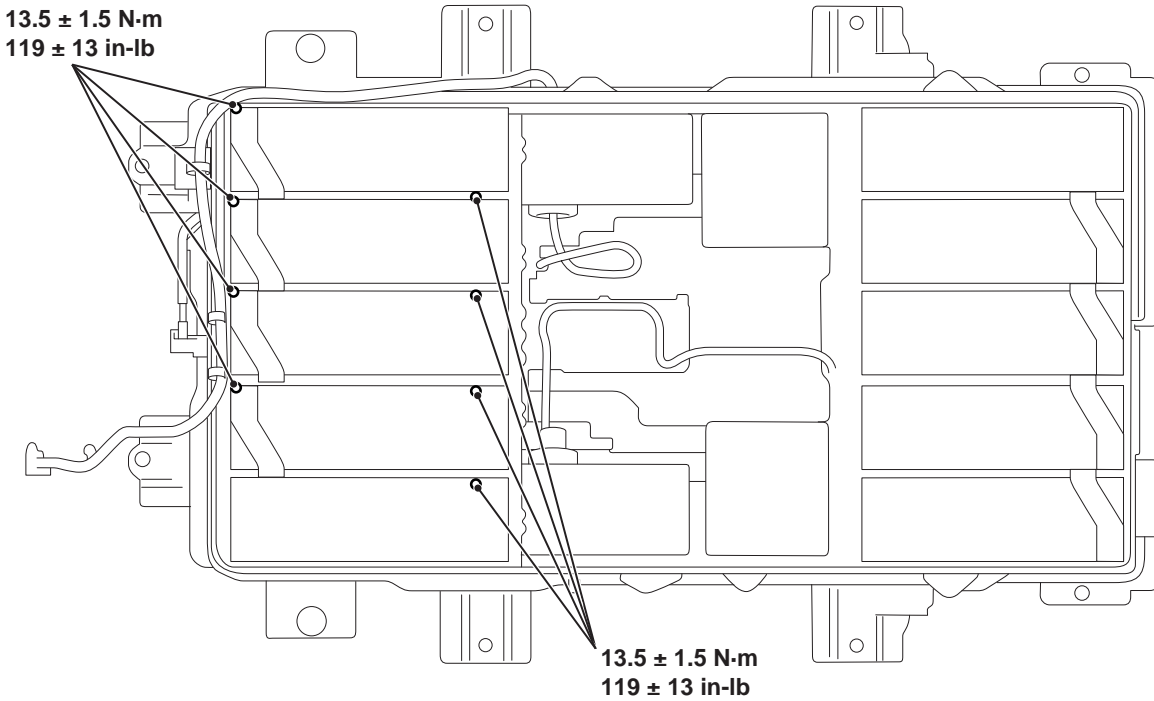

1. Loosen the eight fasteners securing the bus bars to the module.

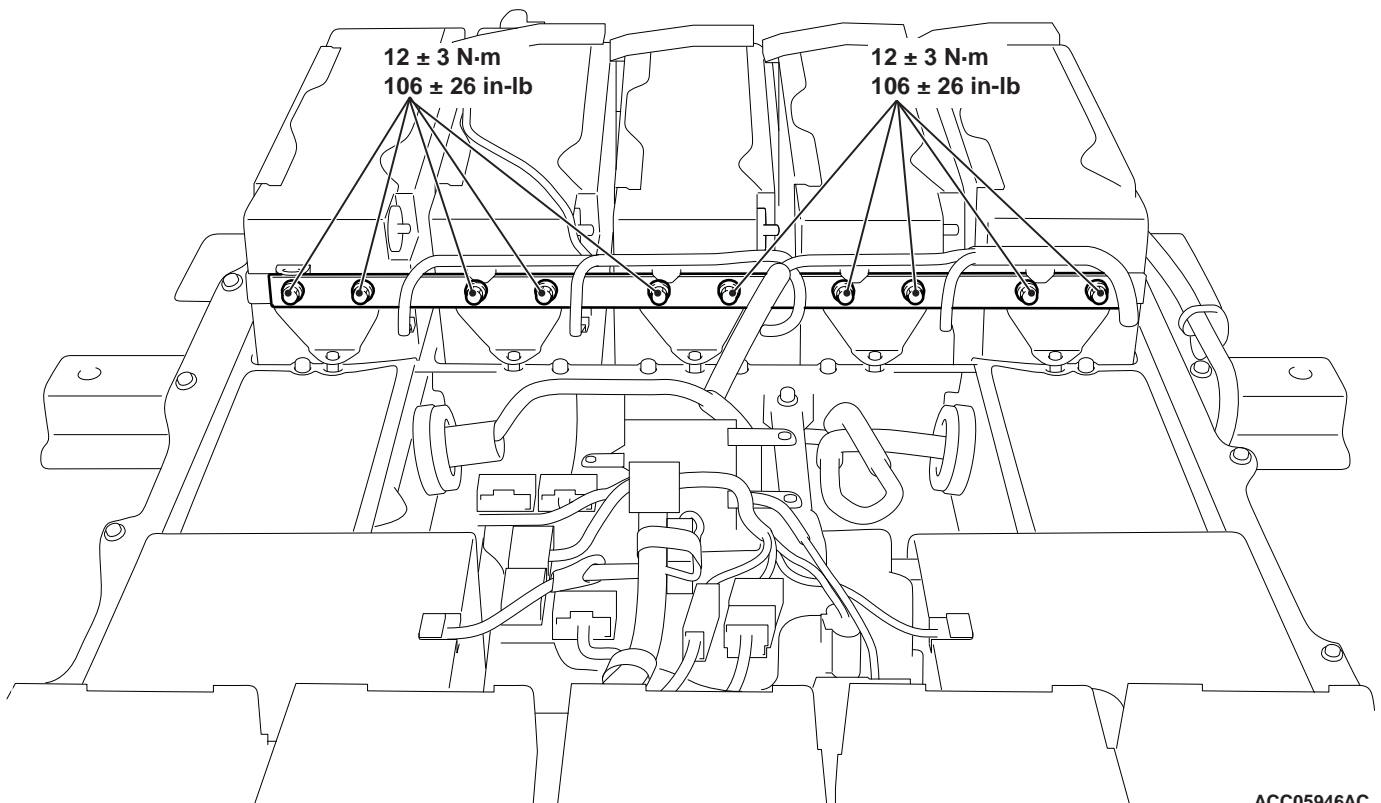

2. Remove the ten module securing fasteners. Then remove the plate from the module.

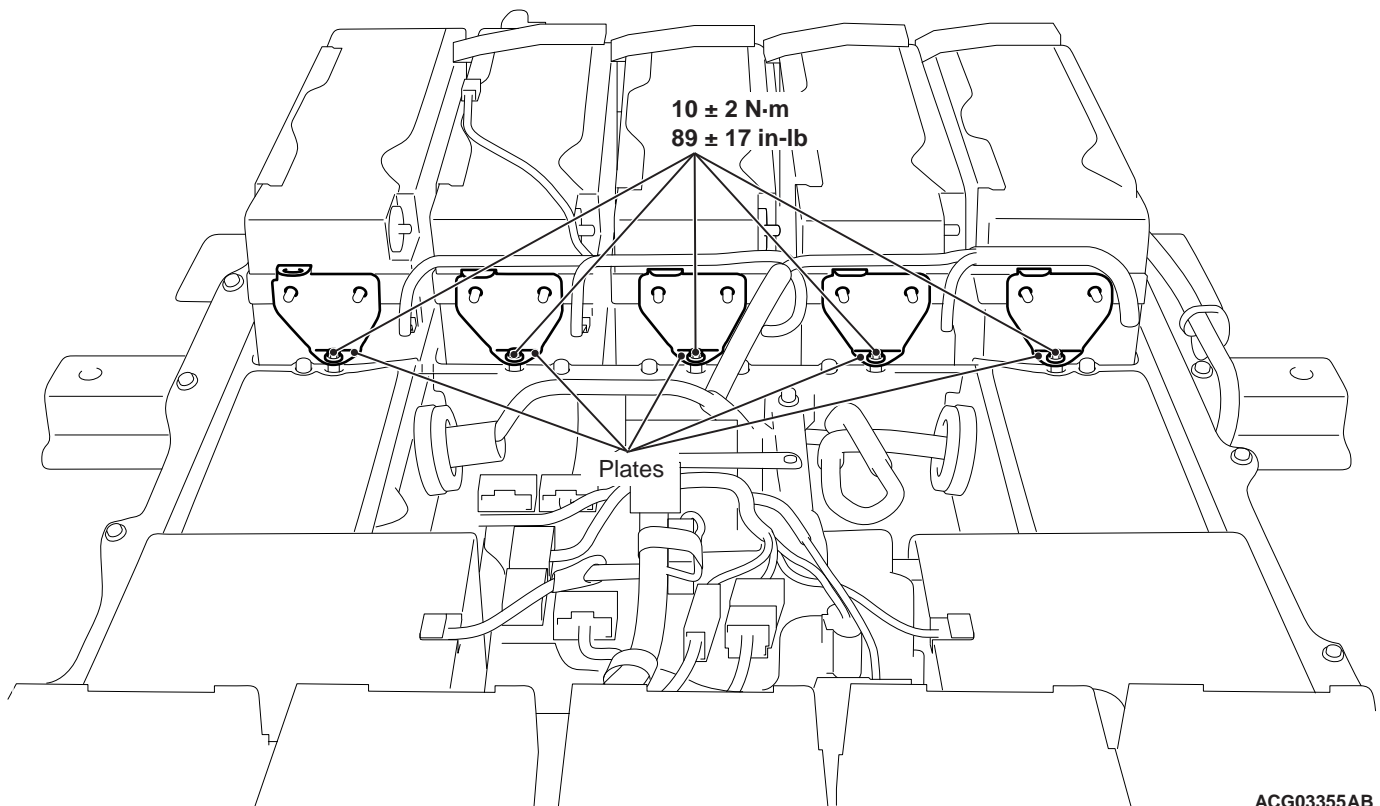

3. Remove the five module securing fasteners.

4. Remove the five plates from the module.

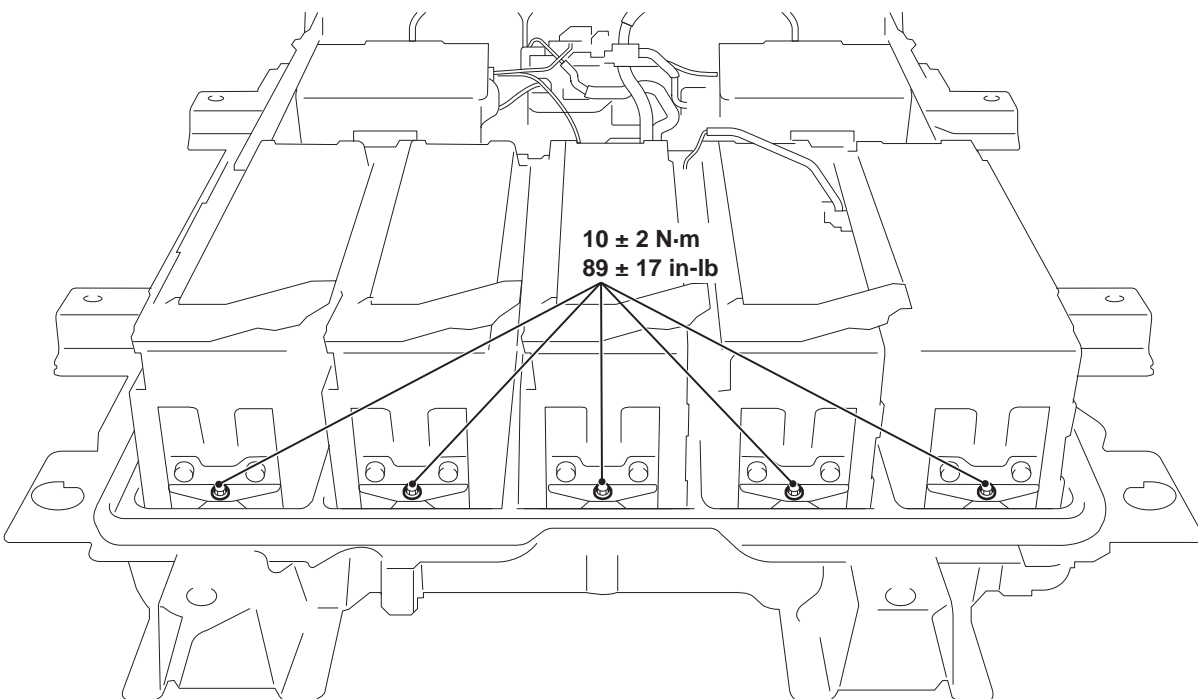

5. Remove the five module securing fasteners.

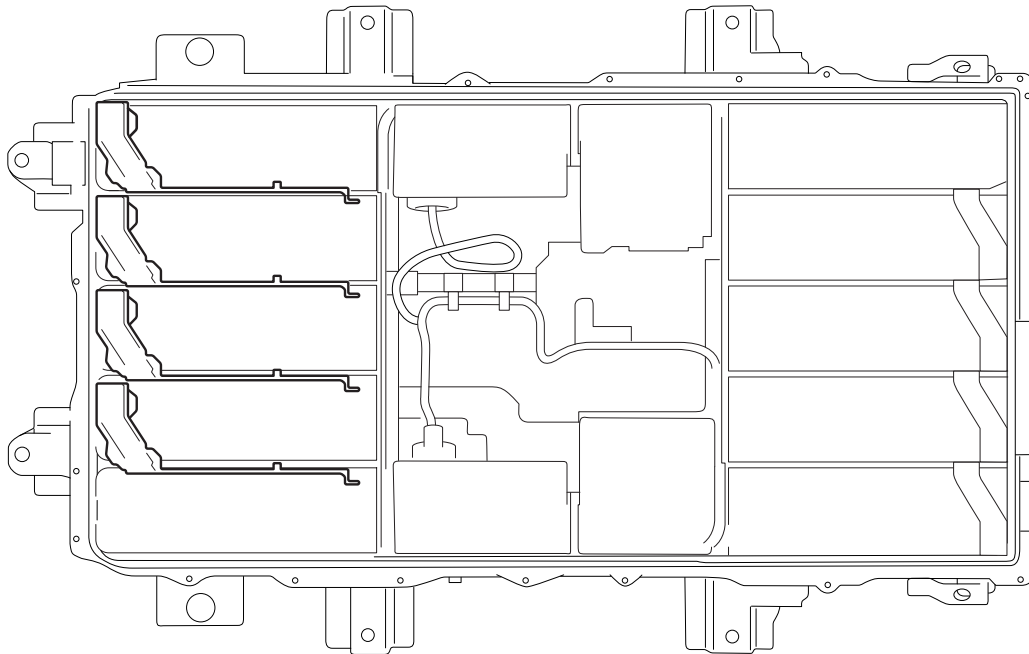

ACC05950

6. Disconnect the bus bars from the module, and then tilt the module to remove the four bus bars.

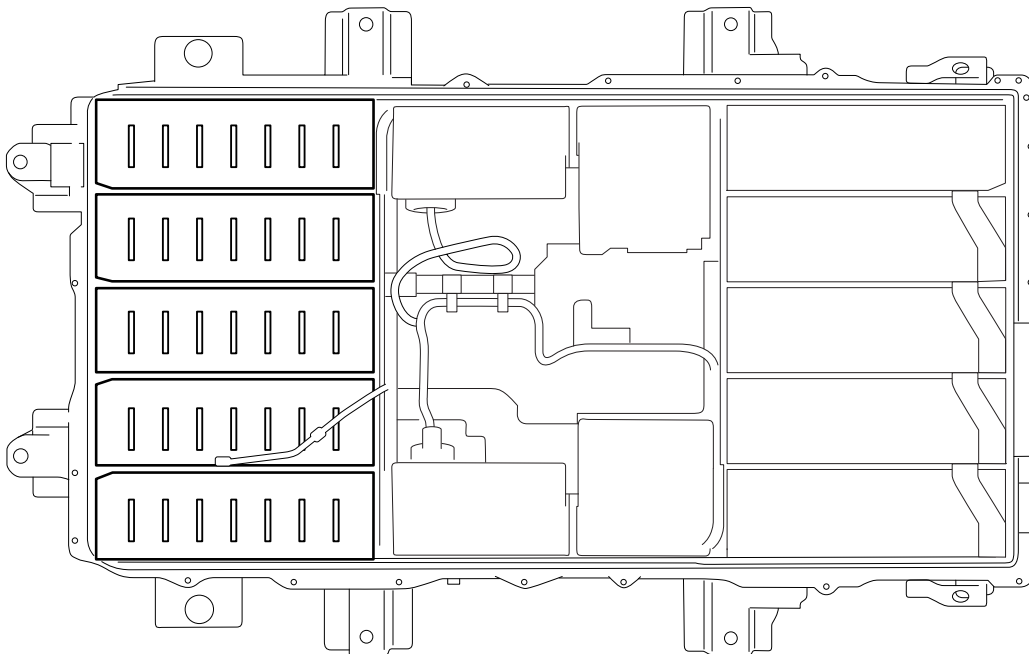

ACC05951

7. Remove the five modules.

JFB COVER REMOVAL AND INSTALLATION

M1549404600055

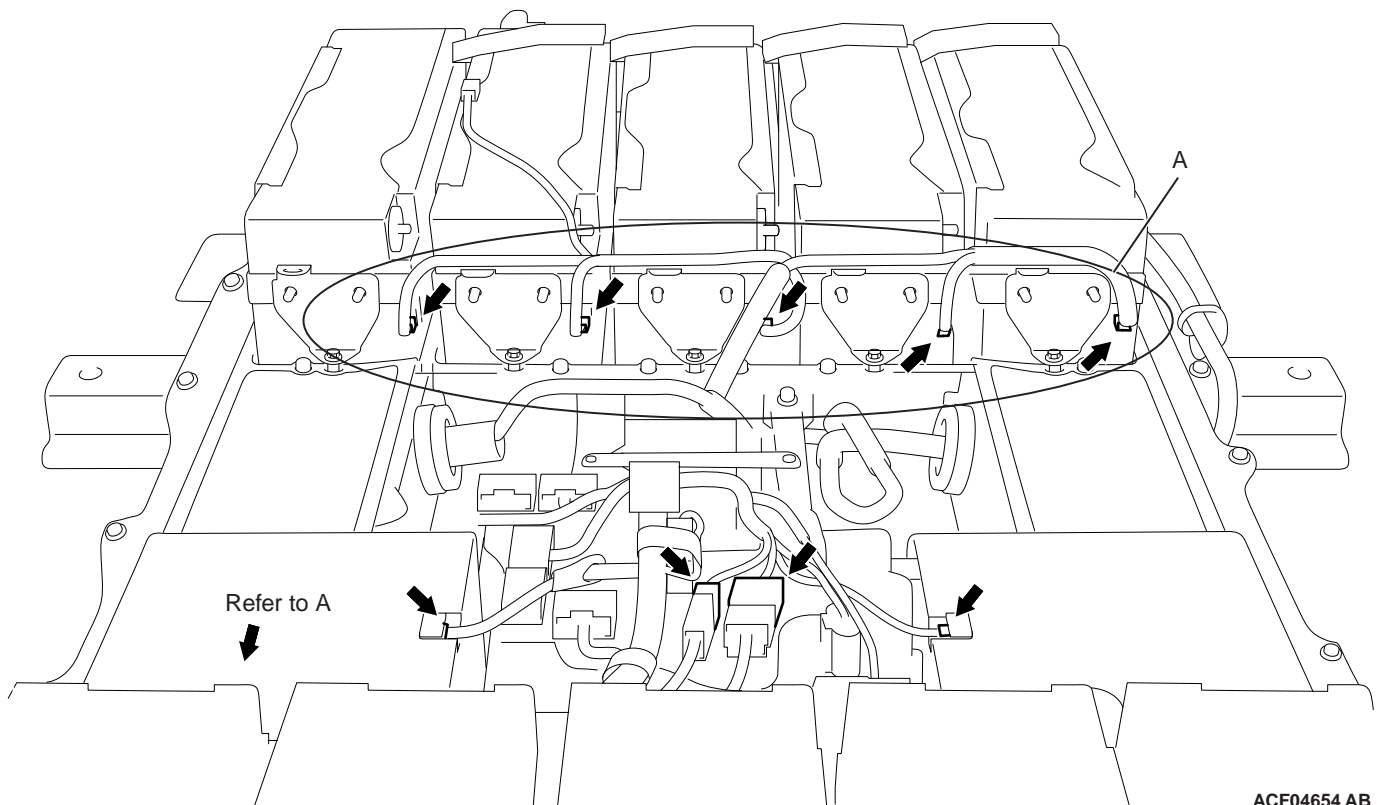

ACF04654 AB

1. Disconnect the contactor connectors from the respective module to remove the wiring harness.

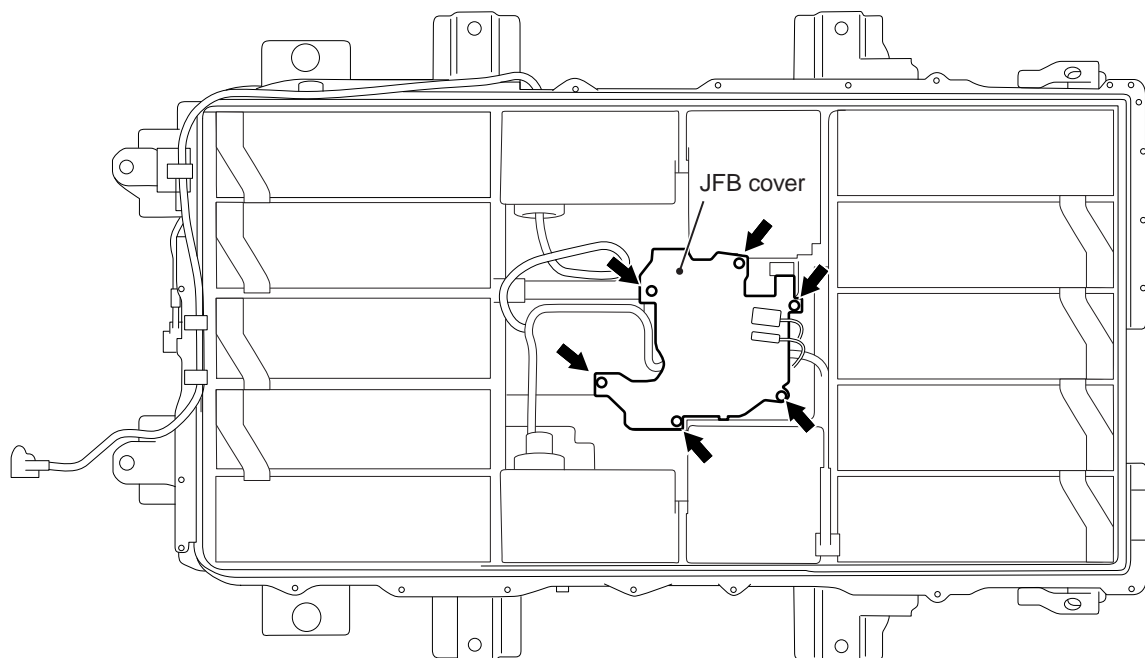

ACC05955AC

2. Disengage the six fasteners and the contactor connector from the JFB cover.

CAUTION

Before loosening the JFB bar, make sure that the four bus bar are removed (Refer to P.54D-197).

3. Remove the JFB cover.

FOUR-CELL MODULE REMOVAL AND INSTALLATION

M1549404700052

NOTE:

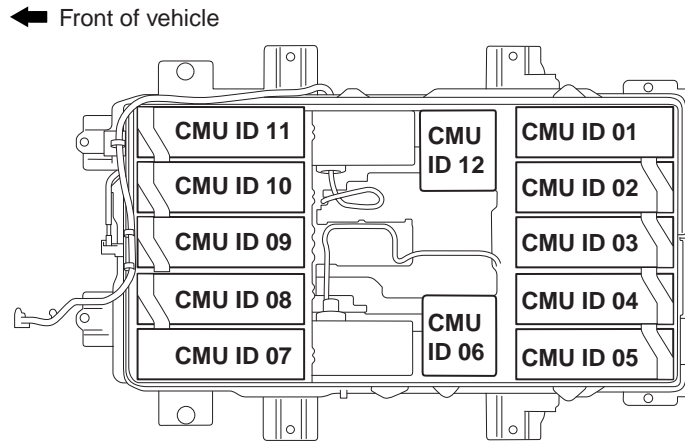

ACC07060AC

The CMU IDs on the module are assigned as shown.

Four-cell module (right side of the vehicle) removal

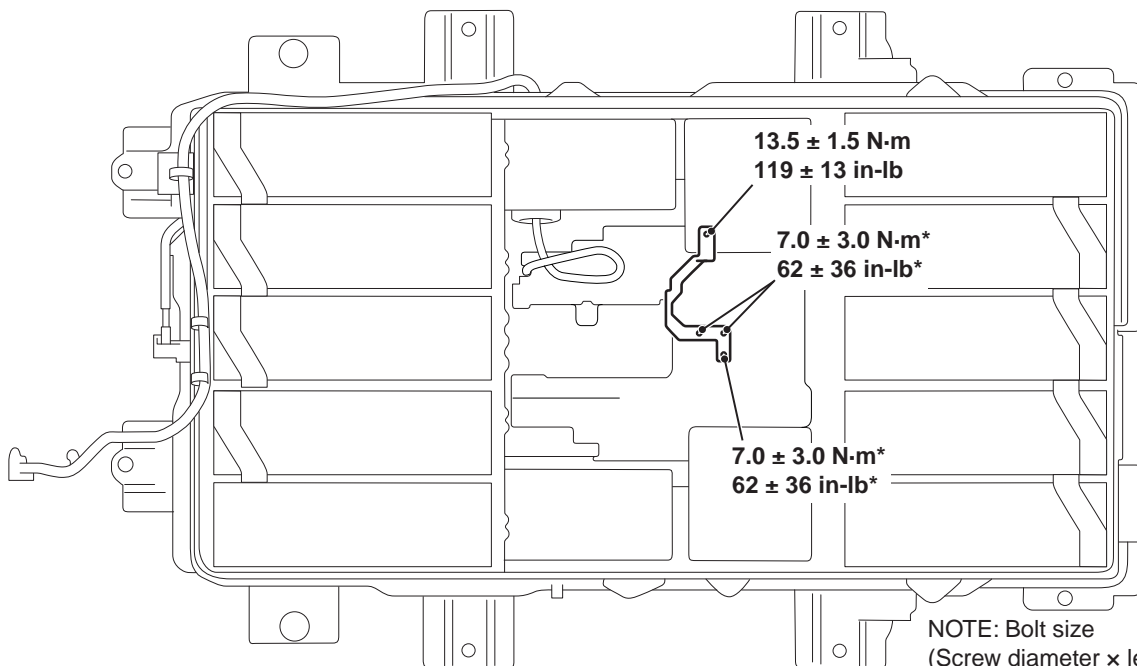

NOTE: Bolt size
 (Screw diameter x length mm)
 : M6 x 8

ACC05957AF

1. Disconnect the bus bar (three locations). Then remove the bus bar.

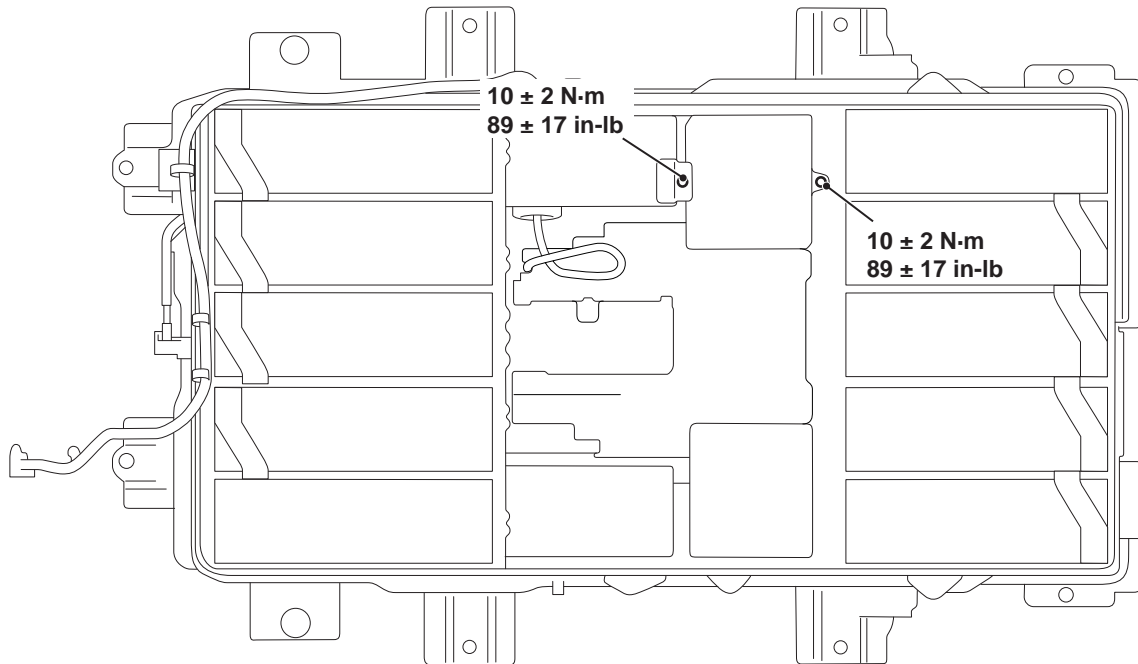

ACC05958 AC

2. Remove the two module securing fasteners.

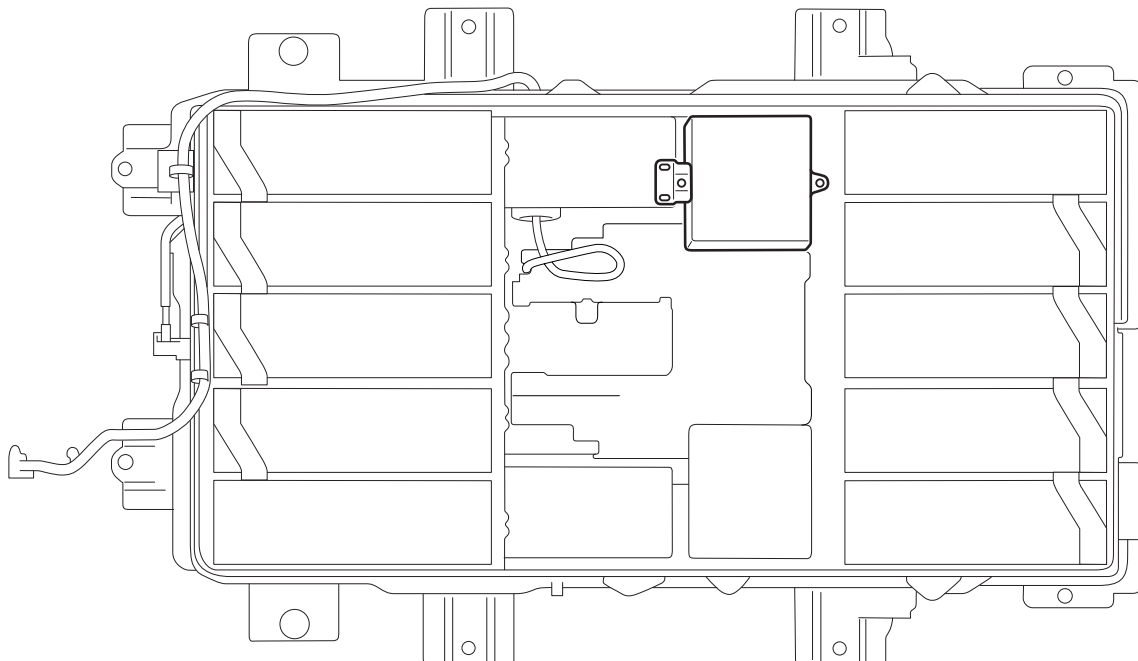

ACC05959

3. Remove the module.

Four-cell module (left side of the vehicle) removal

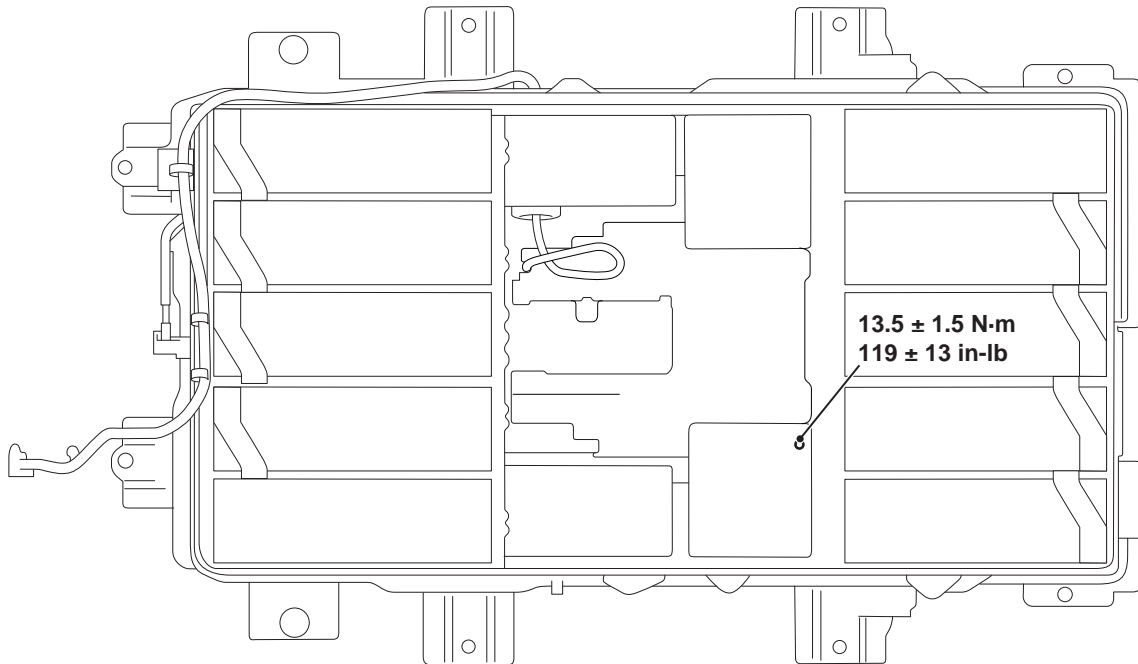

ACC05960AF

1. Disconnect the bus bar (one location).

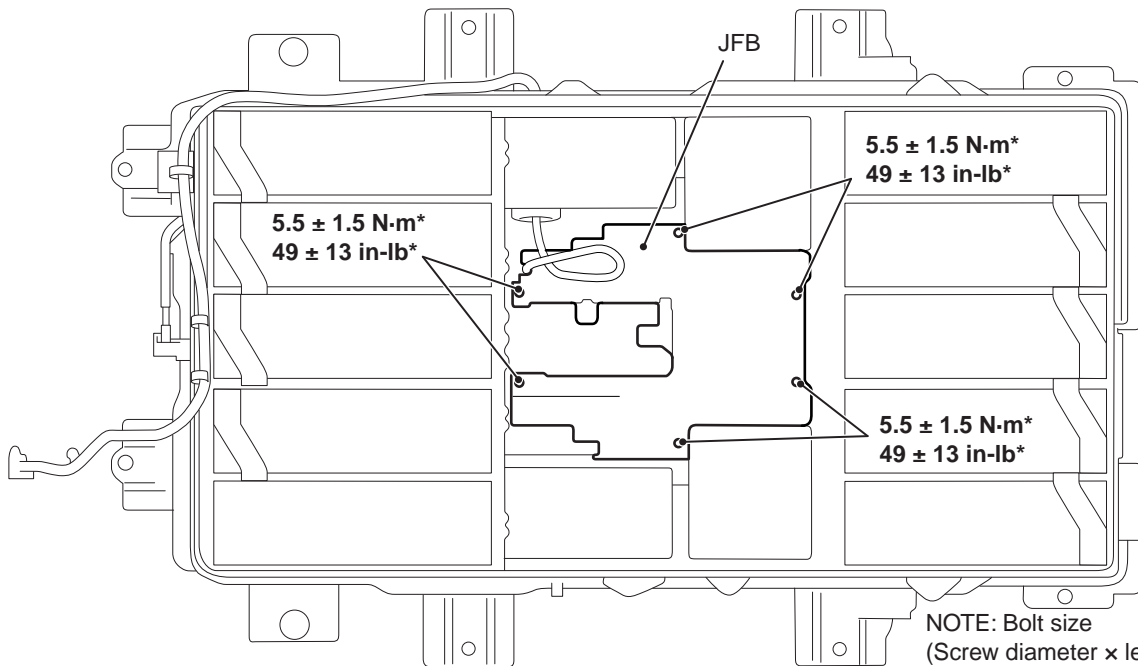

ACC05961AC

2. Remove the six fasteners from the JFB.

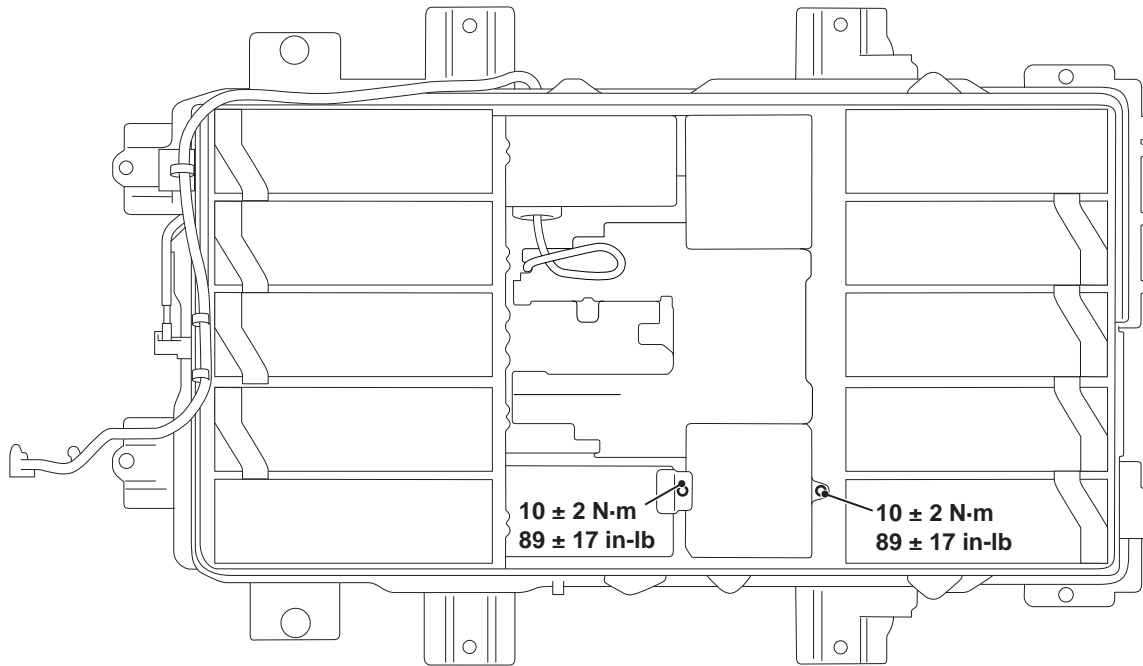

ACC05962AC

3. Remove the two module securing fasteners.

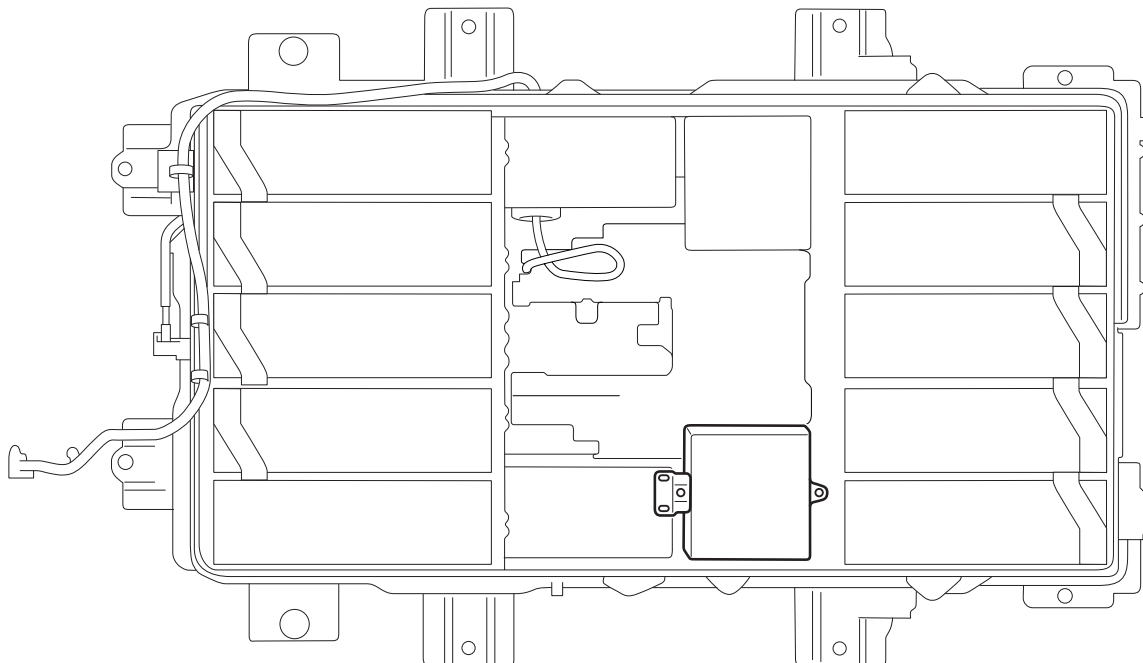

ACC05963

4. Remove the module.

ELECTRIC CURRENT SENSOR REMOVAL AND INSTALLATION

M1549404800059

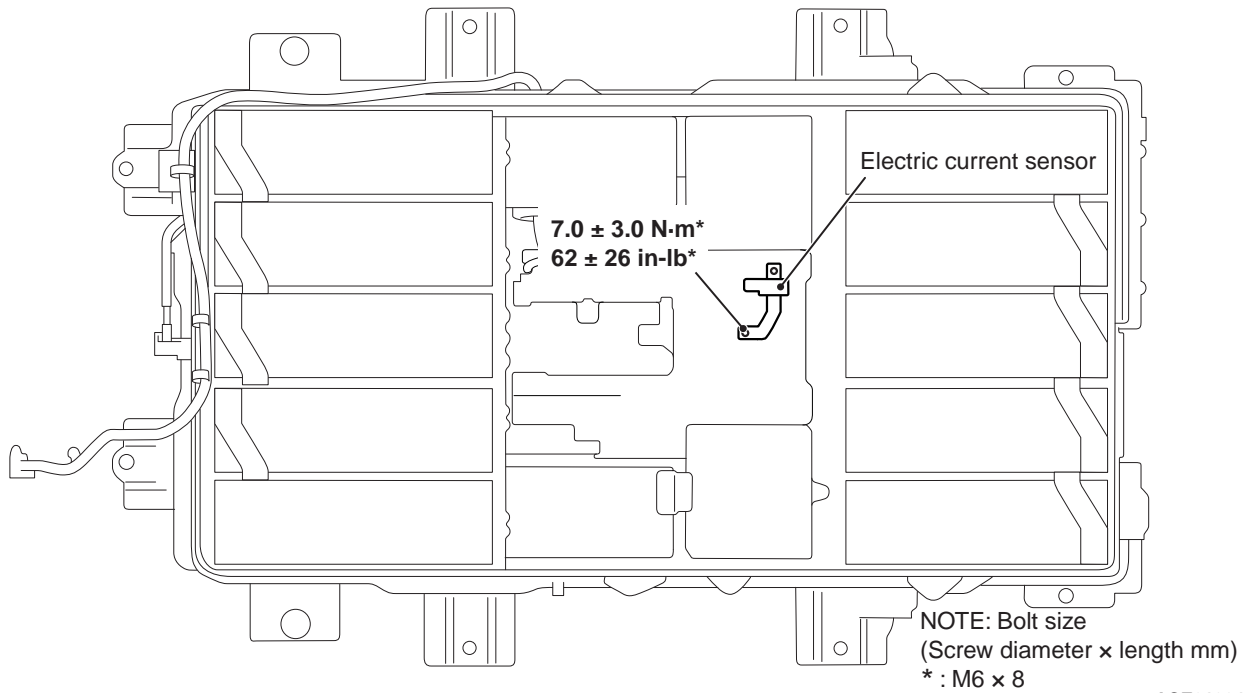

ACE01064 AB

1. Disconnect the bus bar (three locations).
2. Remove the bus bar and the electric current sensor.

JFB REMOVAL AND INSTALLATION

M1549404900078

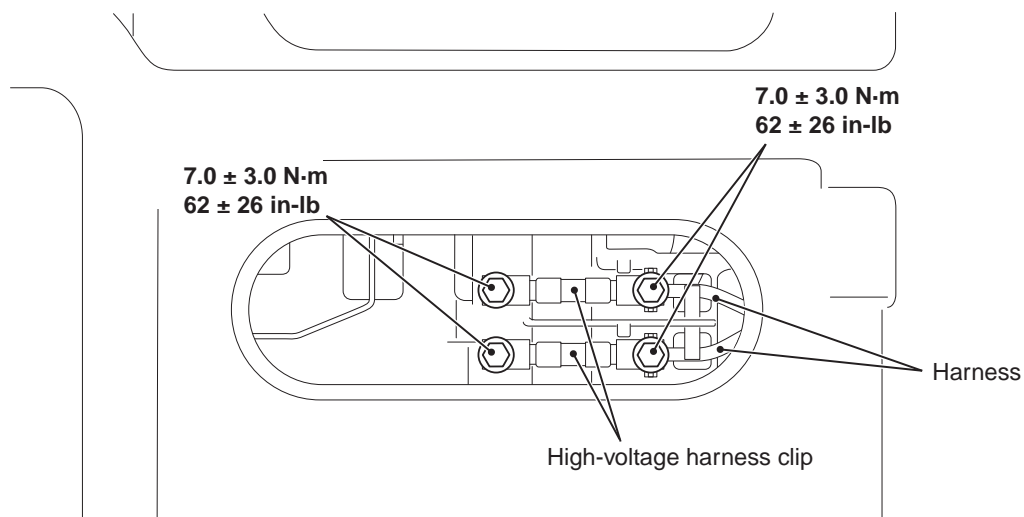

ACC05966AC

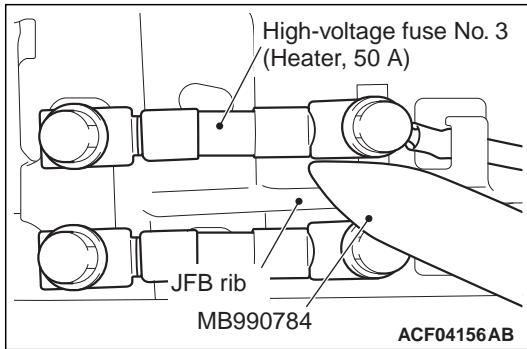
CAUTION

•To pull out high-voltage fuse No. 3 (heater, 50A), wedge the ornament remover (special tool: MB990784) into the JFB ribs to counterhold the fuse.

•When you disconnect the wiring harness from the fuse terminals, be careful not to deform the terminals.

Remove the service hole lid from the bottom of the main drive lithium-ion battery, and loosen the four fuse securing fasteners.

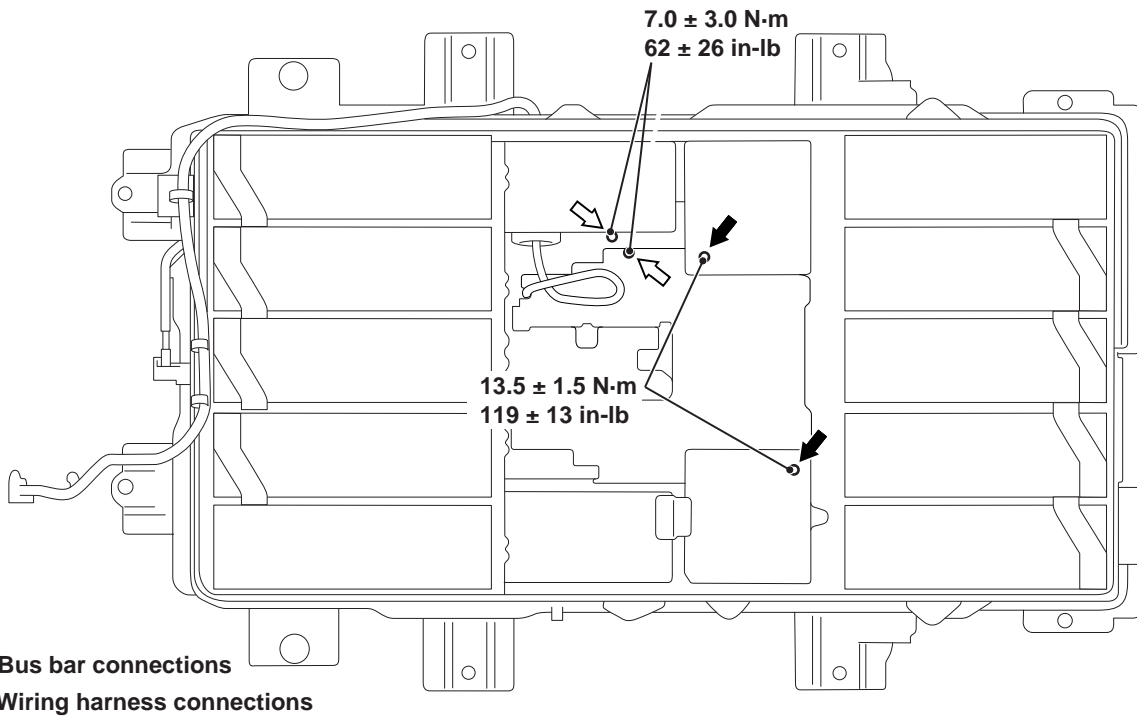

ACC05967AE

1. Loosen the bus bar (two locations) and the wiring harness wires (two locations).

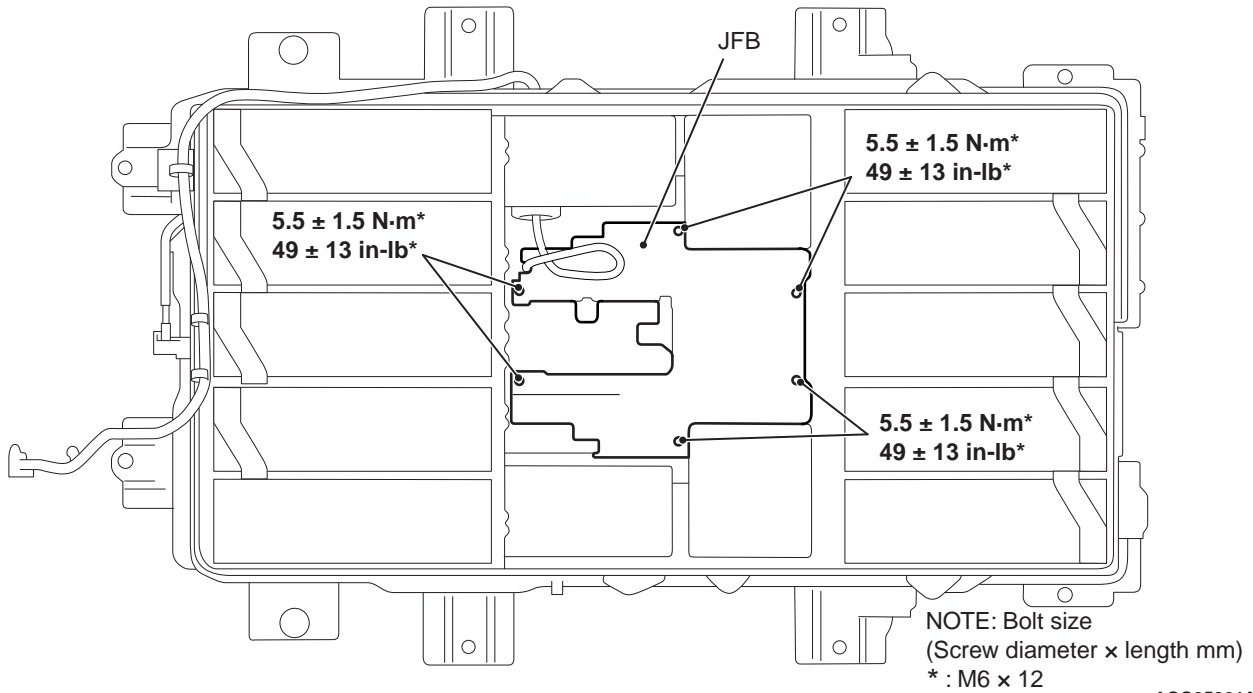

ACC05961AC

2. Remove the six fasteners from the JFB.

3. Remove the JFB.

RESISTOR REMOVAL AND INSTALLATION

M1549405000012

Top surface side of drive battery

Bottom surface side of drive battery

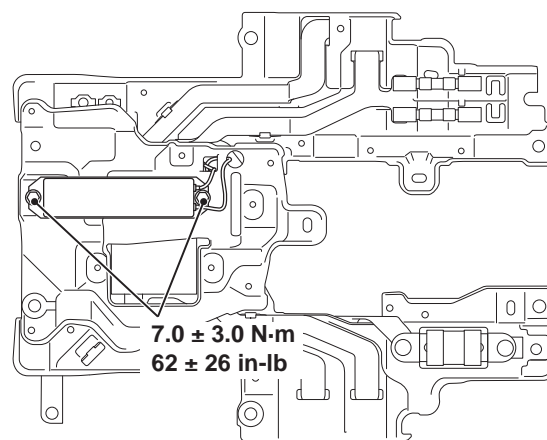
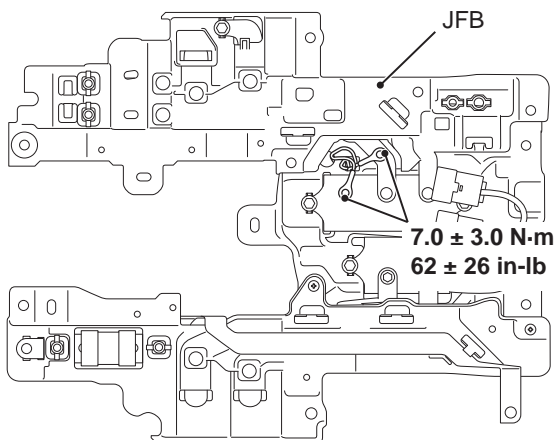

ACC07051AC

1. Remove the two resistor securing fasteners.

2. Remove the resistor.

CONTACTOR REMOVAL AND INSTALLATION

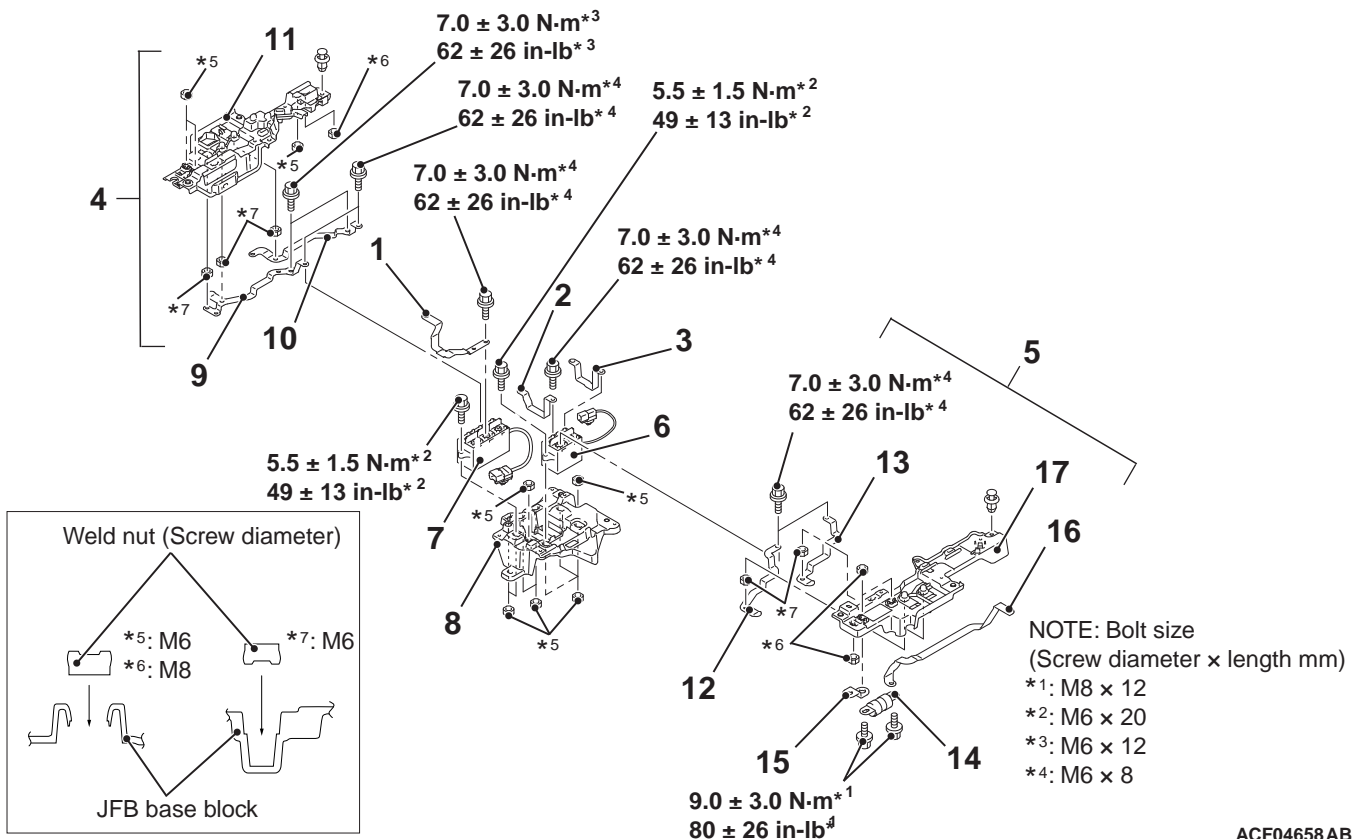

ACF04658 AB

Removal steps

- Four-cell module connection (Refer to P.54D-203)
- 1. JFB bus bar H
- 2. JFB bus bar I
- 3. JFB bus bar J
- 4. JB base block assembly (LH) connection
- 5. JB base block assembly (RH) connection
- 6. Contactor (2P)
- 7. Contactor (3P)

Removal steps (Continued)

- 8. JB centre base block assembly
- 9. JFB bus bar F
- 10. JFB bus bar G
- 11. JB base block assembly (LH)
- 12. JFB bus bar C
- 13. JFB bus bar B
- 14. High-voltage fuse
- 15. JFB bus bar E
- 16. JFB bus bar D
- 17. JB base block assembly (RH)

COOLING FAN REMOVAL AND INSTALLATION

M1549405900059

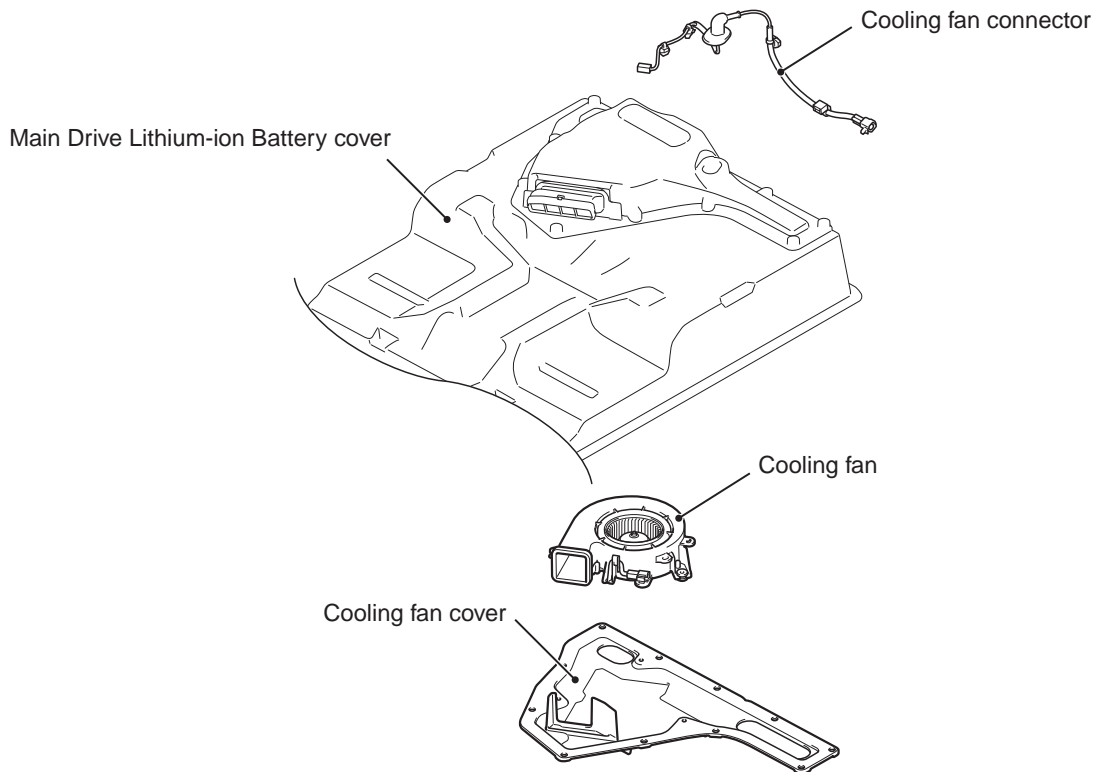

ACC06111AB

1. Remove the 11 fasteners securing the cooling fan cover to the main drive lithium-ion battery cover.
Tightening torque: 7.3 ± 1.2 N·m (65 ± 10 in-lb)
2. Disconnect the cooling fan connector.
3. Remove the three fasteners securing the cooling fan to the cooling fan cover.
Tightening torque: 5.0 ± 2.0 N·m (44 ± 17 in-lb)

INSPECTION

AIR LEAK CHECK

M1549405200113

Preparation for inspection

⚠ CAUTION

Set the special tool securely, or air leak may be caused.

1. Set the work hole lid.
2. Set the service plug cover (MB992928) to the service plug boot.

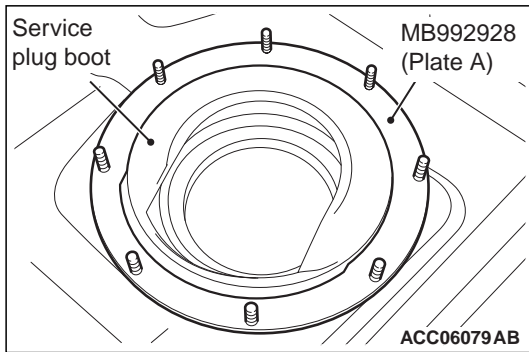

- (1) Set the plate A of the service plug cover (MB992928) to the service plug boot.

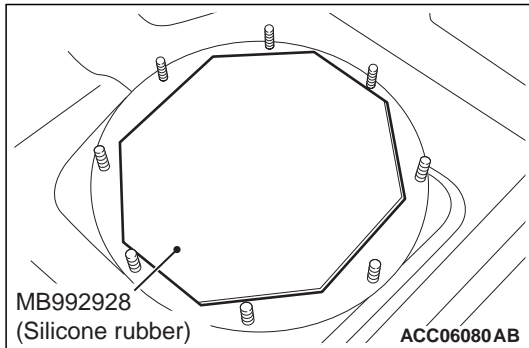

- (2) Put the silicone rubber of the service plug cover (MB992928) on the service plug boot.

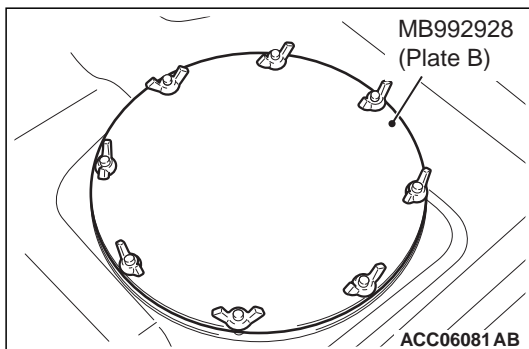

- (3) Set the plate B of the service plug cover (MB992928). Tighten the screws so that the clearance (A) between the plates A and B is even.

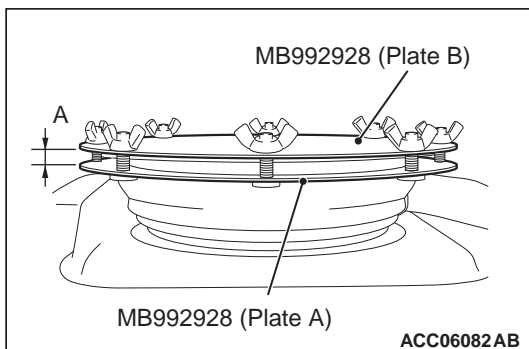

3. Set the duct cover B (MB992933) to the cooling fan outlet.

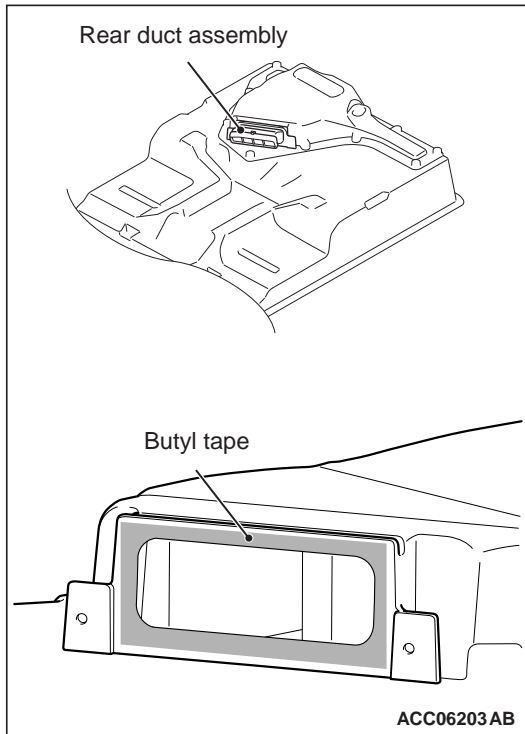

- (1) Remove the rear duct assembly, and remove the butyl tape from the main drive lithium-ion battery side.

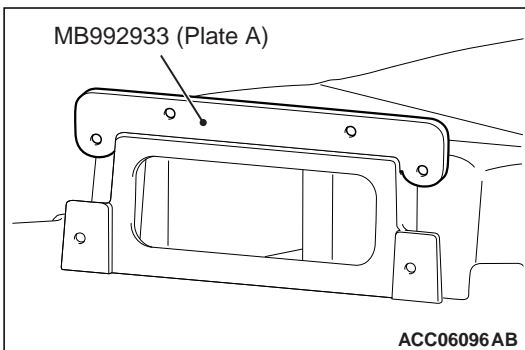

- (2) Engage the plate A of the dust cover B (MB992933) into the groove above the cooling fan outlet.

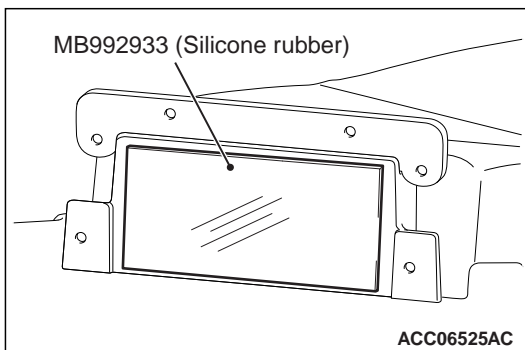

- (3) Use the silicone rubber of the duct cover B (MB992933) to seal the cooling fan outlet. Then secure the plate B of the duct cover B (MB992933) on it.

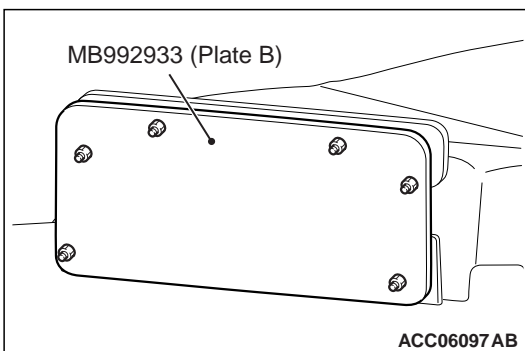

4. Install the plug (MB992930) to the cooling fan inlet.
<Vehicles with main drive lithium-ion battery warming system or quick-charging system>

(1) Make sure that the plug (MB992930) is flush with the cooling fan inlet boot.

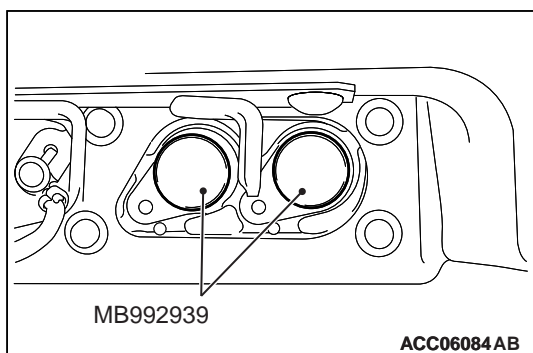
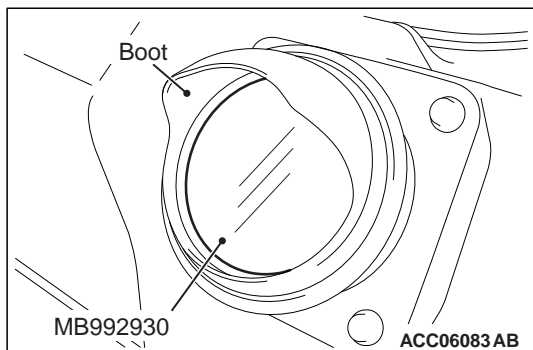

5. Insert the plugs (MB992939) into the ports for the EV charger cables. <Vehicles with main drive lithium-ion battery warming system or quick-charging system>

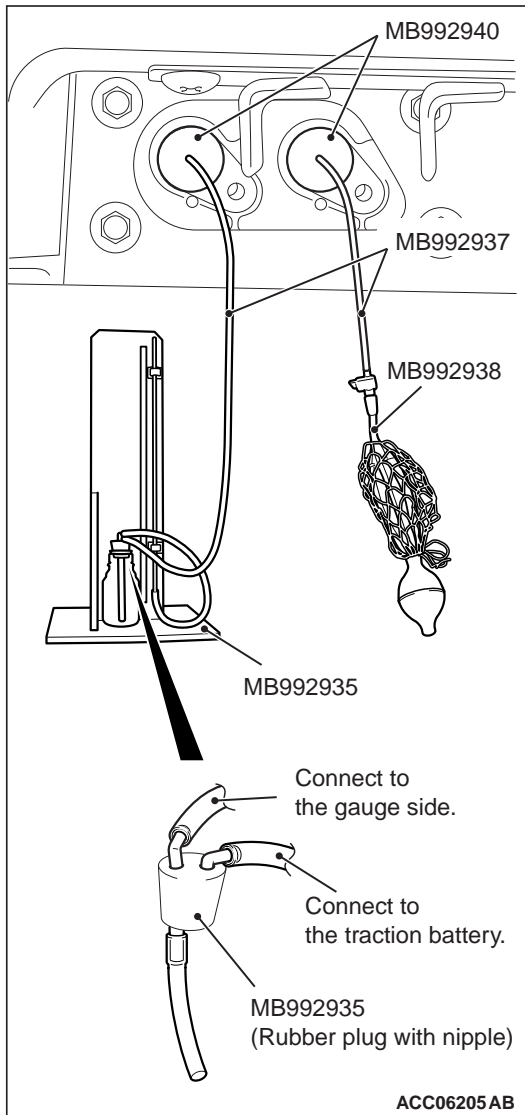

6. Install the pressure gauge unit (MB992935), the hoses (MB992937), the air pump (MB992938) and the nipple (MB992940) into the ports for the EV charger cables. Connect the longer tube spliced at rubber plug with nipples of pressure gauge unit (MB992935) to the gauge on the measuring bench, and connect the shorter tube to the main drive lithium-ion battery.

How to check

⚠ CAUTION

Do not place the pressure gauge unit (MB992935) higher than the main drive lithium-ion battery, or water will intrude into the battery.

1. Pour 200 ml (7.4 fl oz) of water into the bottle of the pressure gauge unit (MB992935).

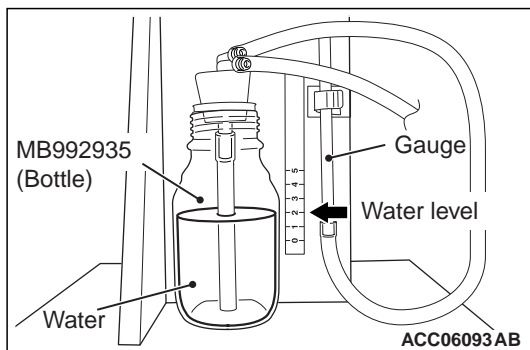

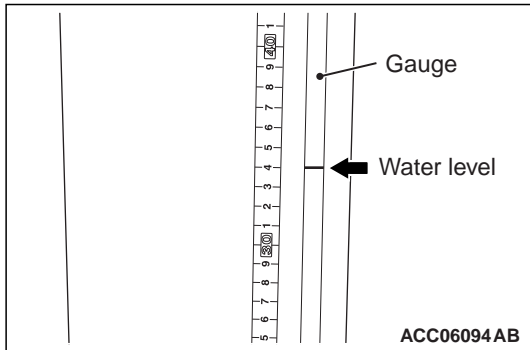
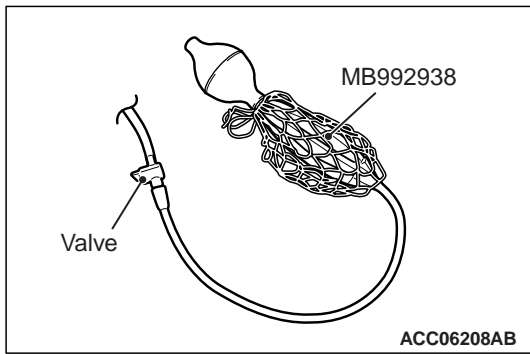

2. Operate the air pump (MB992938) to deliver water into the gauge side of the pressure gauge unit (MB992935) so that the water level in the gauge rises 320 mm (12.6 inch) above the water level in the bottle.
3. Close the valve of the special tool Air pump (MB992938) and then wait for five minutes, Then open the valve again. Then apply pressure to the system so that the water level rises 320 mm (12.6 inch). Then close the valve again and then wait for ten minutes.
4. Then measure the water level inside the gauge.

OK: The water level inside the gauge should fluctuate within 20 mm (0.8 inch).
5. If the water level fluctuation exceeds the specified range, locate air leakage by using soapy water to repair it.

CONTACTOR CHECK

M1549405300024

Checks of main contactor (+), main contactor (-) and electric charging contactor

Main contactor (+)

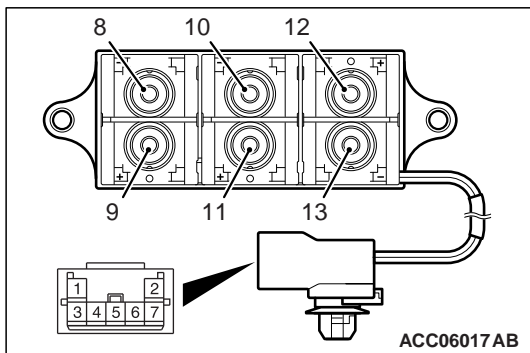

Battery voltage	Terminal number	Normal conditions
Deenergized	10 – 11	No continuity
Energized [between terminal 3 (+) and terminal 1 (-)]		Continuity exists (2 Ω or less).

Main contactor (-)

Battery voltage	Terminal number	Normal conditions
Deenergized	12 – 13	No continuity
Energized [between terminal 4 (+) and terminal 2 (-)]		Continuity exists (2 Ω or less).

Electric charging contactor

Battery voltage	Terminal number	Normal conditions
Deenergized	8 – 9	No continuity
Energized [between terminal 7 (+) and terminal 6 (-)]		Continuity exists (2 Ω or less).

Check of quick-charging contactors (+) and (-)

Quick-charging contactor (+)

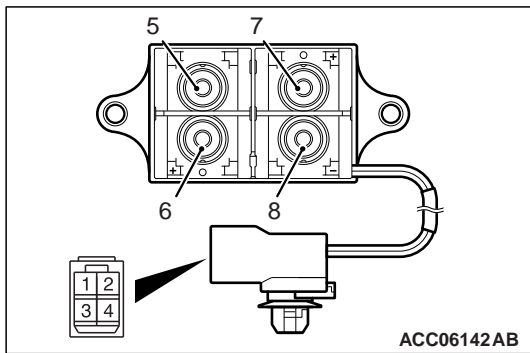

Battery voltage	Terminal number	Normal conditions
Deenergized	5 – 6	No continuity
Energized [terminal 1 (+), terminal 3 (-)]		Continuity exists (2 Ω or less).

Quick charging contactor (-)

Battery voltage	Terminal number	Normal conditions
Deenergized	7 – 8	No continuity
Energized [between terminal 2 (+) and terminal 4 (-)]		Continuity exists (2 Ω or less).

SERVICE PLUG SWITCH INSPECTION

M1549405400010

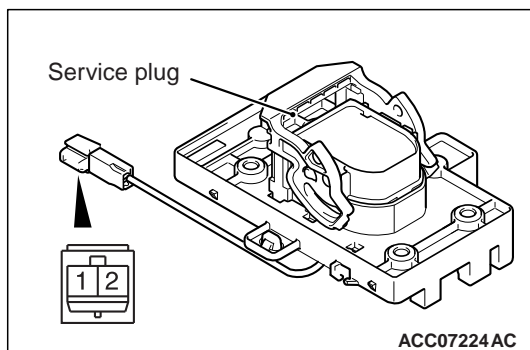

Service plug	Terminal number	Normal conditions
Removed	1 – 2	No continuity
Inserted		Continuity exists (2 Ω or less).

LOCAL CAN TERMINATING RESISTOR CHECK

M1549405500017

1. Remove the cover of the Main Drive Lithium-ion Battery.
 Refer to P.54D-194.

2. Check the terminating resistor.

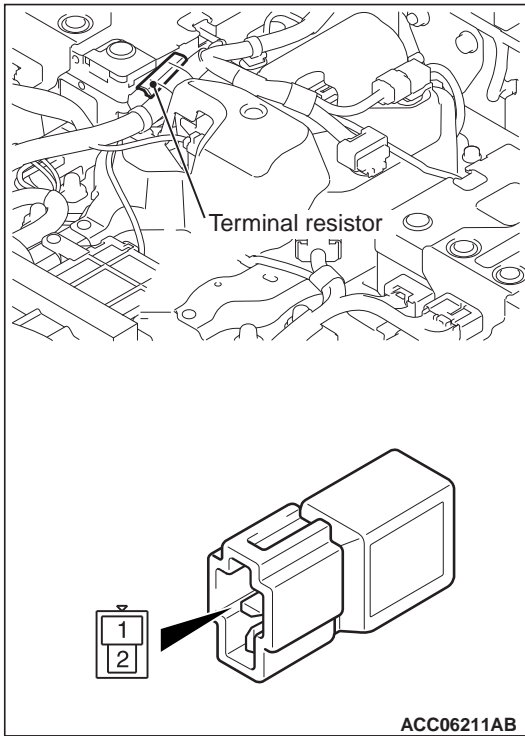

Terminal number	Normal conditions
1 – 2	120 Ω

MAIN DRIVE LITHIUM-ION BATTERY ELECTRIC CURRENT SENSOR CHECK

M1549405600014

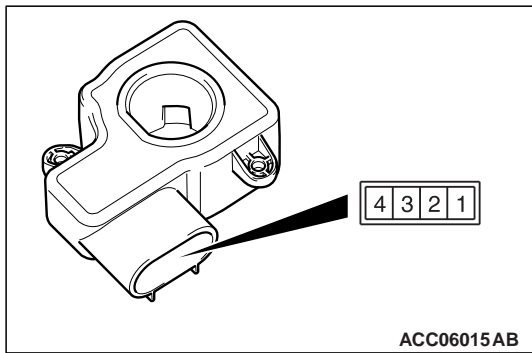

Terminal number	Normal conditions
1 – 3	1 – 5 kΩ [at 25°C (77°F)]
2 – 3	1 – 5 kΩ [at 25°C (77°F)]
4 – 3	1 – 5 kΩ [at 25°C (77°F)]

RESISTOR CHECK

M1549406300050

Measure the resistance of the resistor.

Standard value: 22 – 26 Ω

