

Front Brake Grind/Groan Noise

Service Category Brake

Section Brake (front)

Market USA

Toyota Supports
 ASE Certification 

Applicability

YEAR(S)	MODEL(S)	ADDITIONAL INFORMATION
2009 - 2018	RAV4	VDS(s): BF31V, BF32V, BF33V, BF34V, BF35V, BF4DV, BF4EV, BF9DV, BFREV, BK31V, BK32V, BK33V, BK34V, BK35V, BK4DV, BK9DV, DF4DV, DF4EV, DF9DV, DFREV, DK4DV, DK9DV, EF4DV, EK4DV, JF4DV, JFREV, JK4DV, KF4DV, KF9DV, KK4DV, NFREV, RF4DV, RF4EV, RFREV, RK4DV, WF4DV, WF4EV, WFREV, WK4DV, XF4DV, XK4DV, YF4DV, YF4EV, YF9DV, YFREV, YK4DV, YK9DV, ZF31V, ZF32V, ZF33V, ZF34V, ZF35V, ZF4DV, ZF4EV, ZF9DV, ZFREV, ZK31V, ZK32V, ZK33V, ZK34V, ZK35V, ZK4DV, ZK9DV
2017 - 2018	iM	VDS(s): KARJE

Introduction

Some 2009 – 2018 model year RAV4 and 2017 – 2018 model year iM vehicles may exhibit a grind/groan noise from the front brake pads. An updated pad kit is now available as a service part. Follow the Repair Procedure in this bulletin to address this condition.

Warranty Information

OP CODE	DESCRIPTION	TIME	OFF	T1	T2
473301	R & R Front Pad Kit	0.6	04465-0R031 04465-42180	91	99

APPLICABLE WARRANTY

- This repair is covered under the Toyota Basic Warranty. This warranty is in effect for 36 months or 36,000 miles, whichever occurs first, from the vehicle's in-service date.
- Warranty application is limited to occurrence of the specified condition described in this bulletin.

Front Brake Grind/Groan Noise

Parts Information

PART NUMBER		PART NAME	QTY
PREVIOUS	NEW		
04465-0R031	04465-42210	Pad Kit, Front (16-in. Wheel)	1
04465-42180			

Repair Procedure

1. Confirm the condition exists.
 - A. Is there a grind/groan noise present from the front brake pads?
 - **YES** — Continue to substep B.
 - **NO** — This bulletin does NOT apply. Continue diagnosis using the applicable Repair Manual.
 - B. Are the brake pads below the minimum specification of 1 mm?
 - **YES** — This bulletin does NOT apply. Continue diagnosis using the applicable Repair Manual.
 - **NO** — Continue to step 2.

2. Measure the front brake rotor diameter as shown.
Is the rotor diameter 11.65 in. (296 mm) (16-in. wheel)?
 - **YES** — Use part number 04465-42210 and continue to step 3.
 - **NO** — This bulletin does NOT apply. Continue diagnosis using the applicable Repair Manual.

Figure 1.

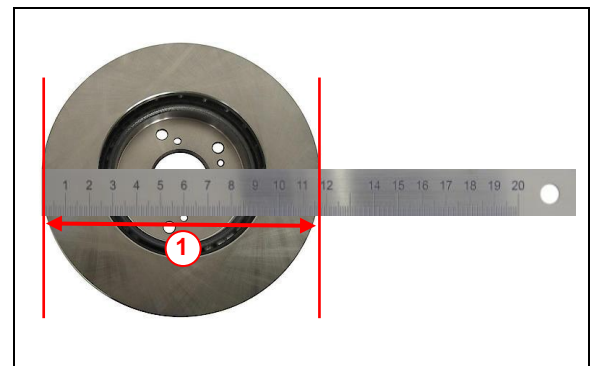

1	Rotor Diameter
----------	-----------------------

Front Brake Grind/Groan Noise

Repair Procedure (continued)

3. Remove the front brake pad kit.
Refer to TIS, applicable model and model year Repair Manual:
 - [2009](#) / [2010](#) / [2011](#) / [2012](#) RAV4:
Brake – Brake (front) – “Brake: Front Brake: Removal”
 - [2013 – 2018](#) RAV4:
Brake – Brake (front) – “Brake (Front): Front Brake: Removal”
 - [2017 – 2018](#) iM:
Brake – Brake (front) – “Brake (Front): Front Brake: Removal”

4. Install the NEW front brake pad kit.
Refer to TIS, applicable model and model year Repair Manual:
 - [2009](#) / [2010](#) / [2011](#) / [2012](#) RAV4:
Brake – Brake (front) – “Brake: Front Brake: Installation”
 - [2013 – 2018](#) RAV4:
Brake – Brake (front) – “Brake (Front): Front Brake: Installation”
 - [2017 – 2018](#) iM:
Brake – Brake (front) – “Brake (Front): Front Brake: Installation”

5. Road-test the vehicle to confirm proper brake operation and that the condition is no longer present.