



# Technical Journal

TITLE:

Rear air suspension- Dust cover loose on SPA

<b>REF NO:</b> TJ 30517.6.0	<b>ISSUING DEPARTMENT:</b> Technical Service	<b>CAR MARKET:</b> United States and Canada	
<b>PARTNER:</b> 3 US 7510 Volvo Car USA		<b>ISSUE DATE:</b> 2019-02-25	<b>STATUS DATE:</b> 2019-03-06
<b>FUNC GROUP:</b> 7261	<b>FUNC DESC:</b> Cylinder; bellows	Page 1 of 18	

“Right first time in Time”

## Attachment

File Name	File Size
TJ 30517 A.PNG	0.9118 MB
TJI-488219-1_1_1_en-US.pdf	1.4180 MB
TJI-488219-2_1_0_en-US.pdf	4.3463 MB

## Vehicle Type

Type	Eng	Eng Desc	Sales	Body	Gear	Steer	Model Year	Plant	Chassis range	Struc Week Range
234							2017-2017		0000001-0044124	201617-201810
235							2017-2018		0000001-0063976	201620-201810
236							2017-2018		0000001-0034772	201646-201810
238							2018-2018		0000001-0051621	201646-201810
246							2018-2018		0000001-0096113	201717-201810
256							2016-2018		0000001-0376406	201505-201810

## CSC Customer Symptom Codes

Code	Description
3L	Technician information/Repair information/Not for warranty use



## VST Operation Number

VST Operation Number	Description
36050-2	US-Calibrating/Identifying with VIDA
98611-2	Air suspension rear Installation acc, to TJ30517
36060-3	Calibration with VIDA

## DTC Diagnostic Trouble Codes

Rows beginning with \* are modified

Note! If using a printed copy of this Technical Journal, first check for the latest online version.

## Text

### DESCRIPTION:

If the dust cover loose from the top of the rear air suspension- see picture TJ 30517 A.PNG. Follow advice under service.

### SERVICE:

If a car comes in with a loose dust cover, replace complete air spring according to VIDA.

If the dust cover on the other side is not loose and has a plastic tie strap (black or white), update the plastic tie strap on the air spring with a new metal tie strap according to attached instruction

**VCC-488219-1** or **VCC-488219-2**.

New metal strap introduced 18w09 in production.

Note: Always follow VIDA instruction.

### VEHICLE REPORT:

Please follow the general TIE Reporting guidelines available in the TIE system under “Instructions” or the SPJ 27125 TIE Quick Guide (Dealers).

If this information cannot be found, please check other SPJ’s or TJ’s released locally by your market responsible office has released their own local report guide.

\* Yes, please submit Vehicle Reports on vehicles built after structure week 18w10.

Use concern area “Vehicle Report” and sub concern area “Support Not Needed”, use function group 7261.

**To view TJ attachments continue to next page. This TJ has three attachments.**





## Volvo Car Customer Service

TJ Instruction VCC-488219-1

<b>Title</b>	Air suspension, rear	<b>Page</b>	1 ( 5 )
<b>Action</b>	Installation	<b>Operation number:</b>	98611-2 36050-2 36060-3

Issue	Date	Reason
1	2015-09	First issue

### Affected vehicles

Model year	Model
2017, 2018, 2019	V90 Cross Country
2018, 2019	XC60 (18-)
2016, 2017, 2018, 2019	XC90 (16-)

### Materials

Materials	Qty.	Part No.	Notes
Clamp	1.0	32269500	

### Special tools

Description	Part No.
Lock grip pliers	981 4201

## Removal

**Note! Removal steps in this procedure may contain installation details.**

Remove relevant side rear wheel , refer to:  
Removal, replacement and installation  
7 - Springs and wheels  
77 - Wheels, tyres, hubs  
770 - general

Empty air springs according to: Diagnostics/  
Components/ ECU / SUM / Diagnostic  
Sequences / Deflating and filling air springs and  
reservoir

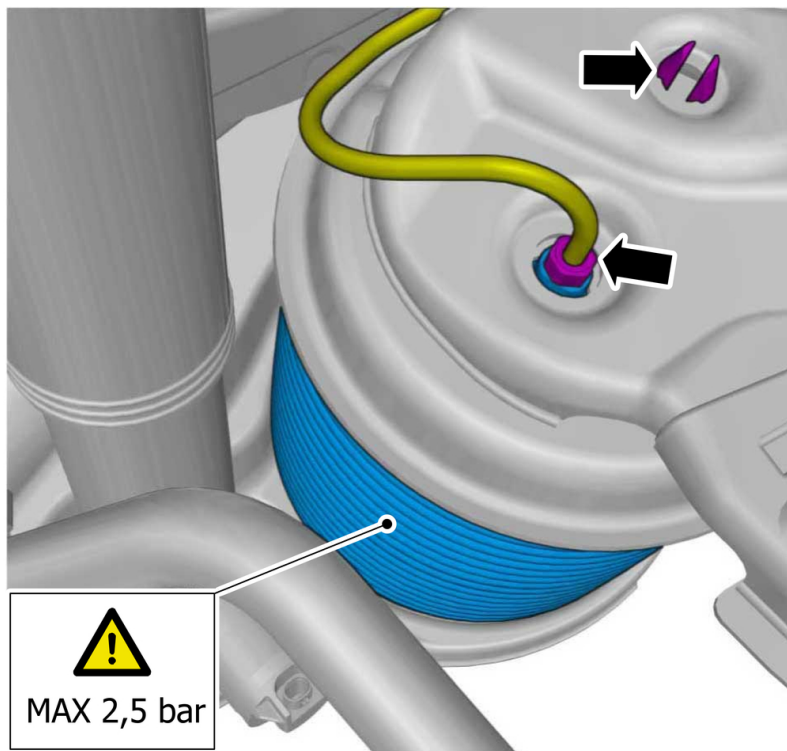

Undo the hose from the connection.

**Torque:**

Air hose connector, to Connector with plastic threads , 3 Nm

Depress the locking device.

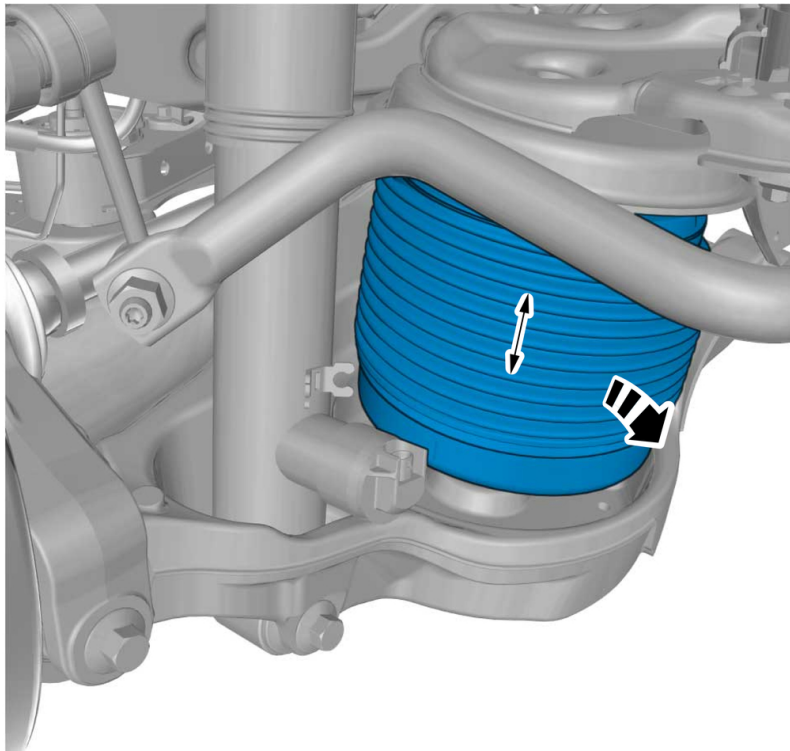

Remove the marked part.

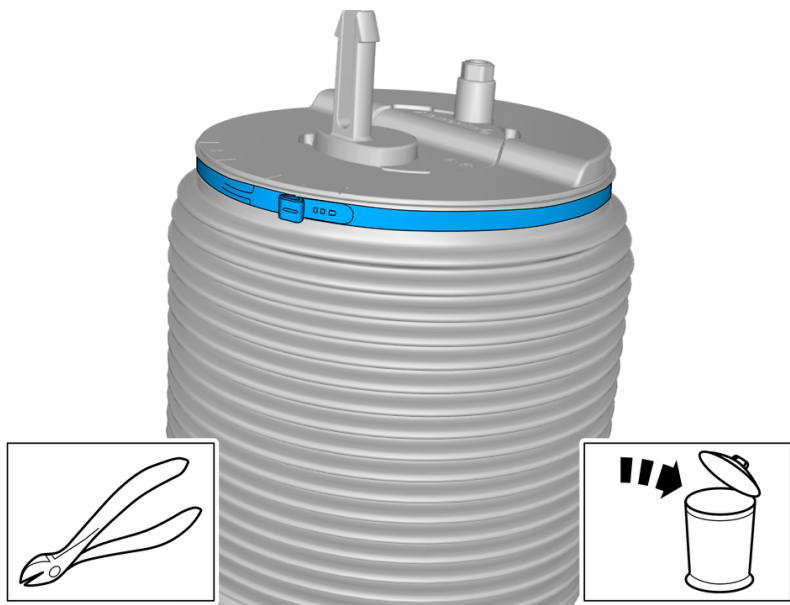

Remove the cable tie(s).

### Installation

Applies to the left-hand side:



**Caution! Make sure that the component is positioned correctly.**

Tighten the cable tie.

Applies to the right-hand side



On both sides.



**Note! Make sure that a new clamp is installed.**

Install the marked component.

Special Tool: T9814201, Lock grip pliers

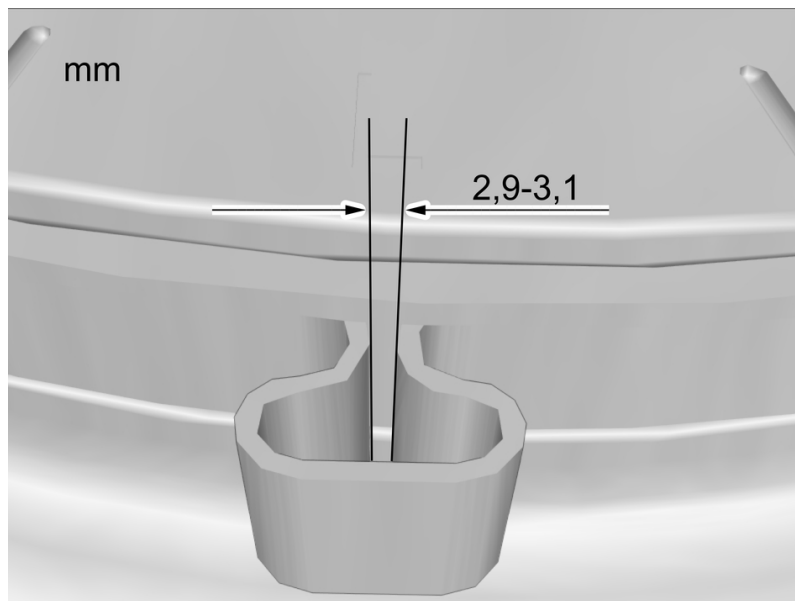

**Caution! Make sure the component is fitted as illustrated.**

To install, reverse the removal procedure.

Fill air springs according to: Diagnostics/ Components/ ECU / SUM / Diagnostic Sequences / Deflating and filling air springs and reservoir

**Caution! Make sure that the air springs are inflated before lowering the vehicle.**





## Volvo Car Customer Service

TJ Instruction VCC-488219-2

<b>Title</b>	Air suspension, rear	<b>Page</b>	1 ( 10 )
<b>Action</b>	Installation	<b>Operation number:</b>	98611-2 36050-2 36060-3

Issue	Date	Reason
1	2019-01	First issue

### Affected vehicles

Model year	Model
2017, 2018, 2019	S90 (17-)
2017, 2018, 2019	S90L
2017, 2018, 2019	V90 (17-)

### Special tools

Description	Part No.
Lock grip pliers	981 4201

## Removal

**Note! Removal steps in this procedure may contain installation details.**

Deactivate the Air suspension control in Settings, which is found in Center Console Display top view or by way of VIDIA: Diagnostics/Components/ECU/SUM/Diagnostic sequences/Enable leveling control

Remove relevant side rear wheel , refer to:  
Removal, replacement and installation  
7 - Springs and wheels  
77 - Wheels, tyres, hubs  
770 - general

Empty air springs according to: Diagnostics/Components/ ECU / SUM / Diagnostic Sequences / Deflating and filling air springs and reservoir

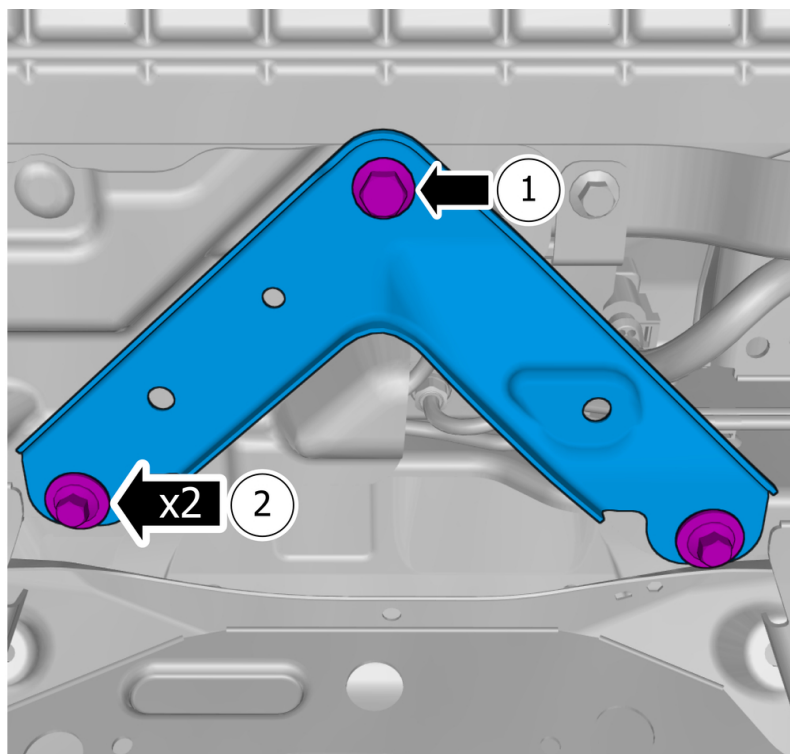

Remove the screws.

### Torque:

- Stage 1 : Reinforcement plate, to Rear subframe , 50 Nm
- Stage 2 : Reinforcement plate, to Rear subframe , 125°

Remove the marked part.

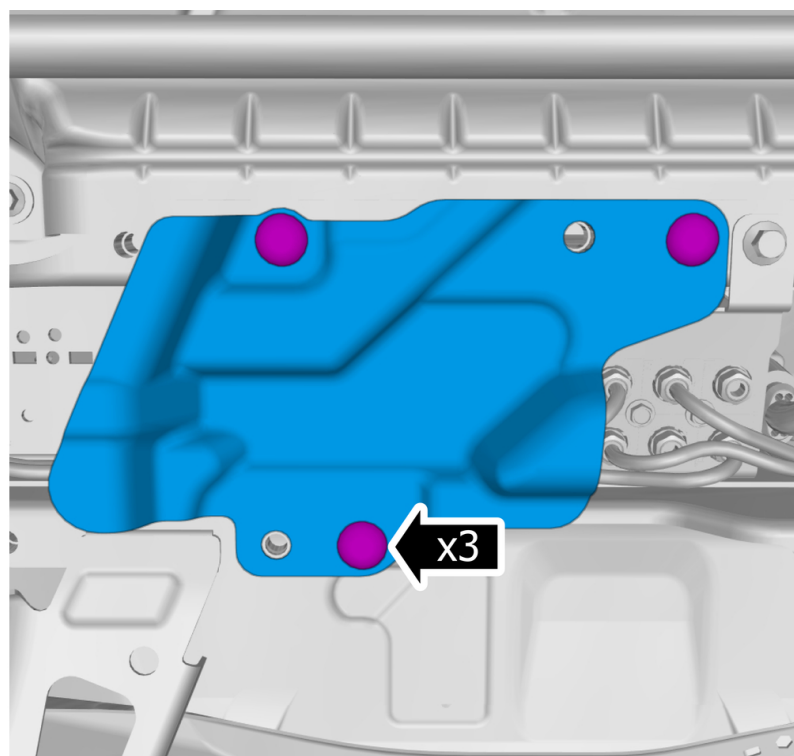

Remove the clips.  
Install the marked component.

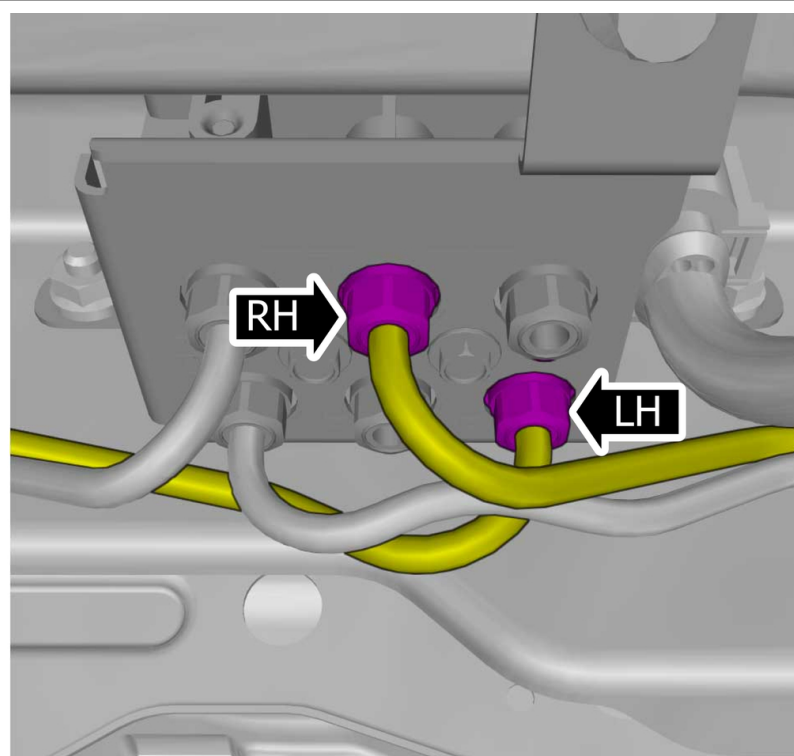

Locate relevant marking.  
Undo the hose from the connection.

**Torque:**

Air hose connector, to Connector with plastic threads , 3 Nm

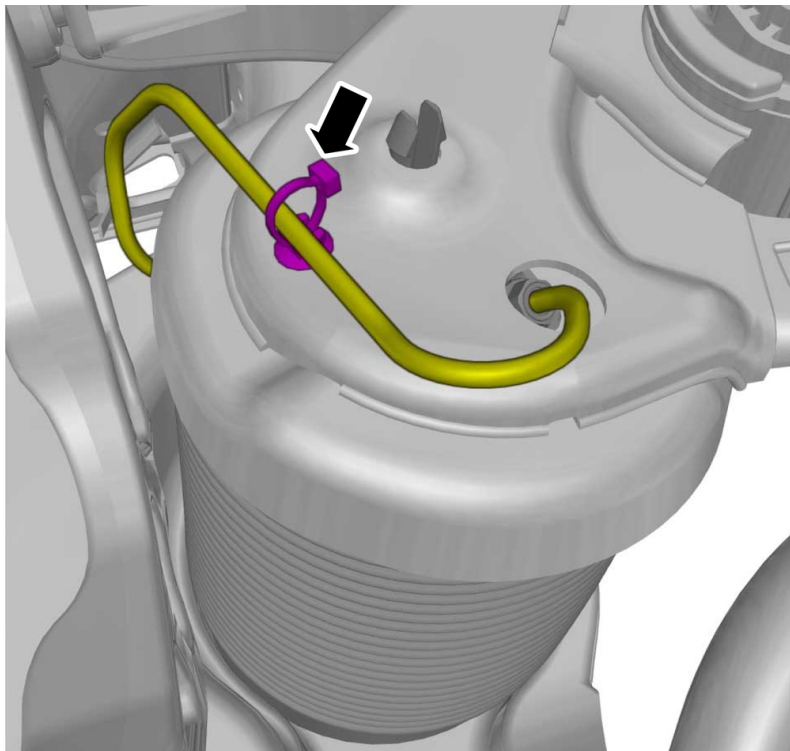

Remove the clip.

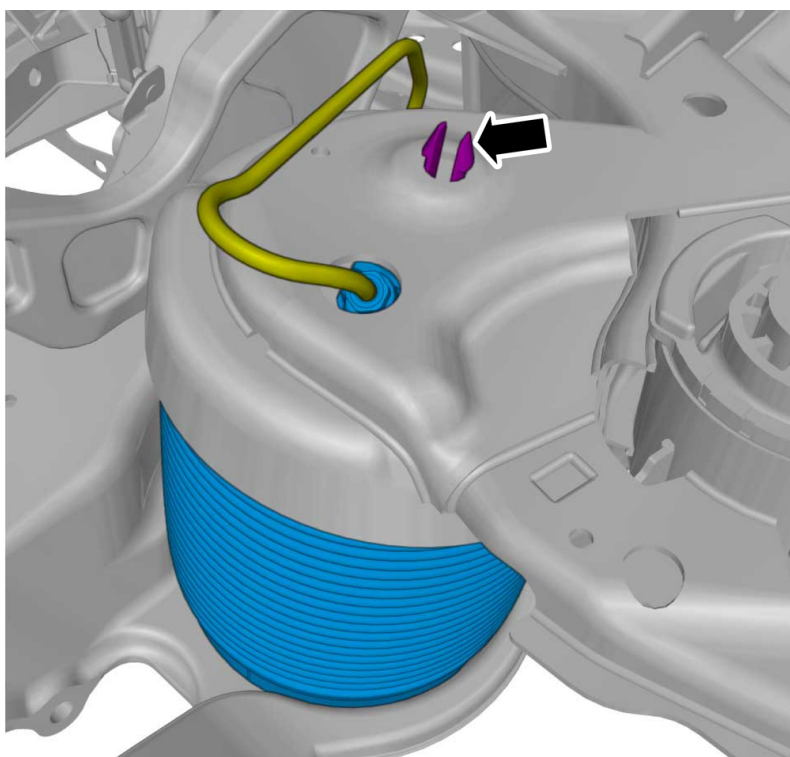

Depress the locking device.

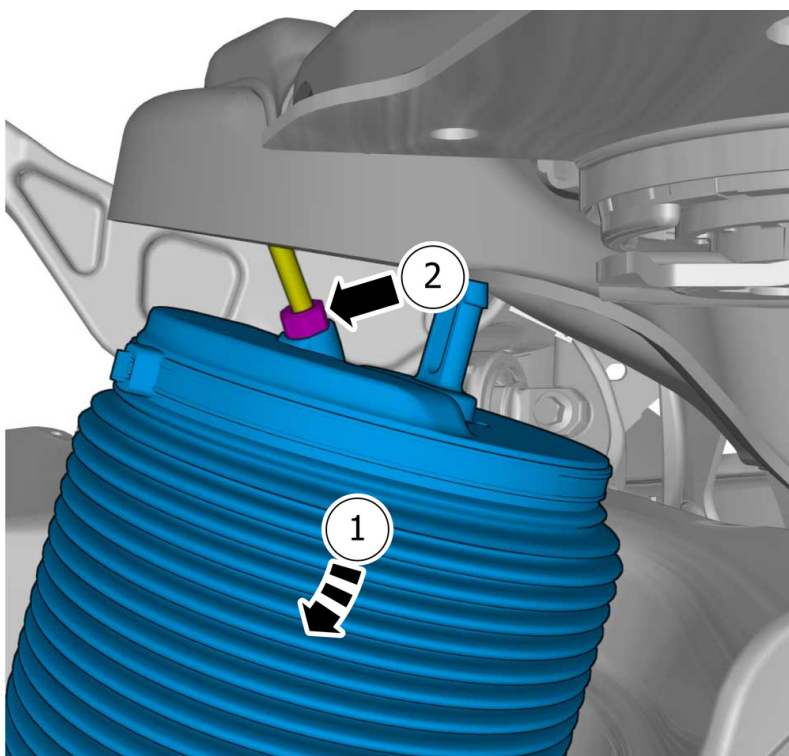

**Caution! Be extra careful when removing or installing this component.**

- 1 . Lift the marked component forward.
- 2 . **Torque:**  
Air hose connector, to Connector with plastic threads , 3 Nm

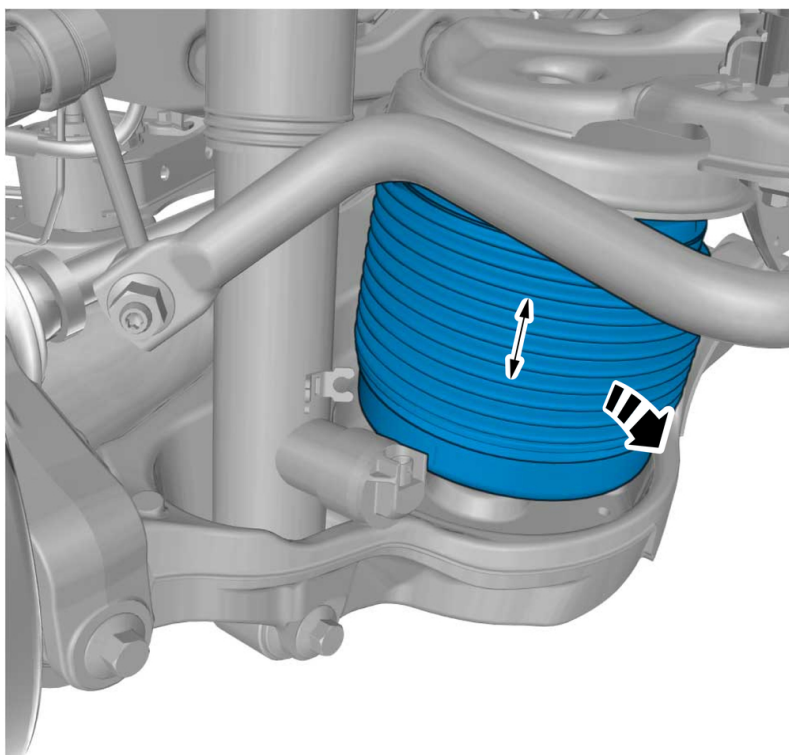

Remove the marked part.

Remove the cable tie(s).

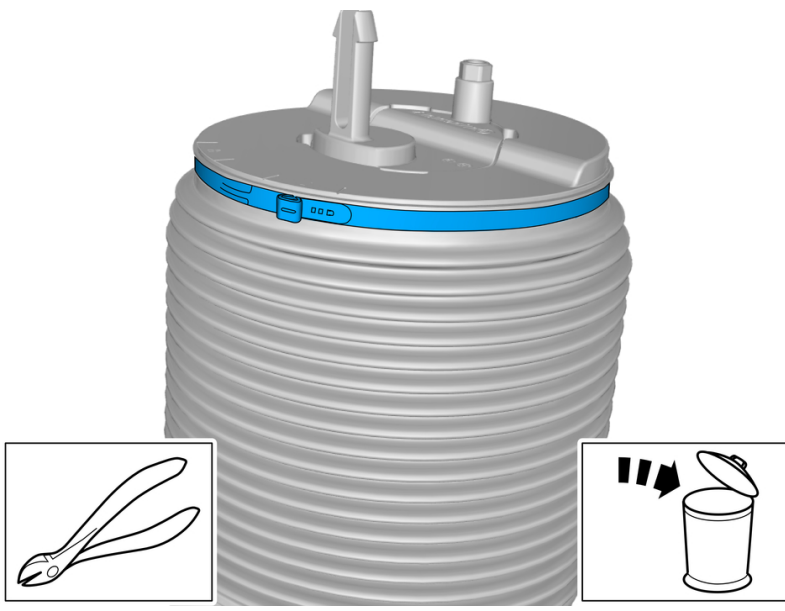

**Installation**

Applies to the left-hand side:



**Caution! Make sure that the component is positioned correctly.**

Applies to the right-hand side



**Caution! Make sure that the component is positioned correctly.**

On both sides.



**Note! Make sure that a new clamp is installed.**

Install the marked component.

Special Tool: T9814201, Lock grip pliers

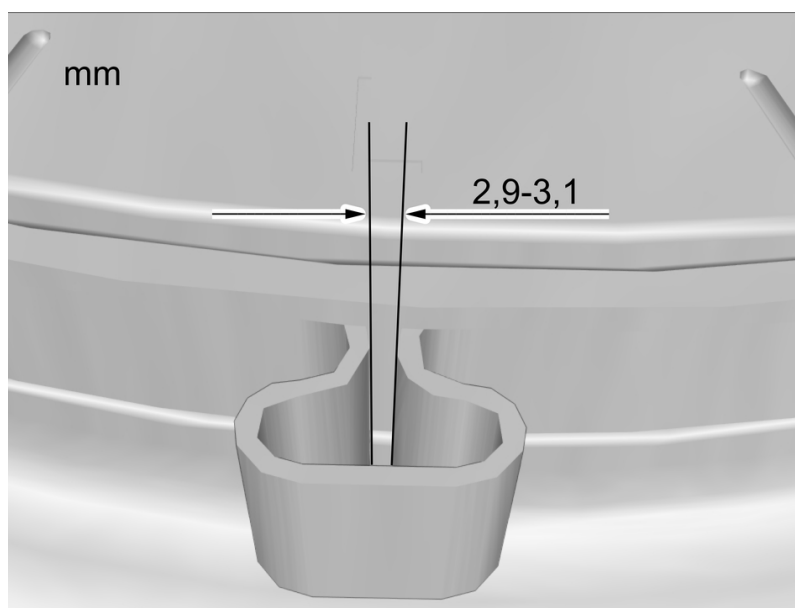

**Caution! Make sure the component is fitted as illustrated.**

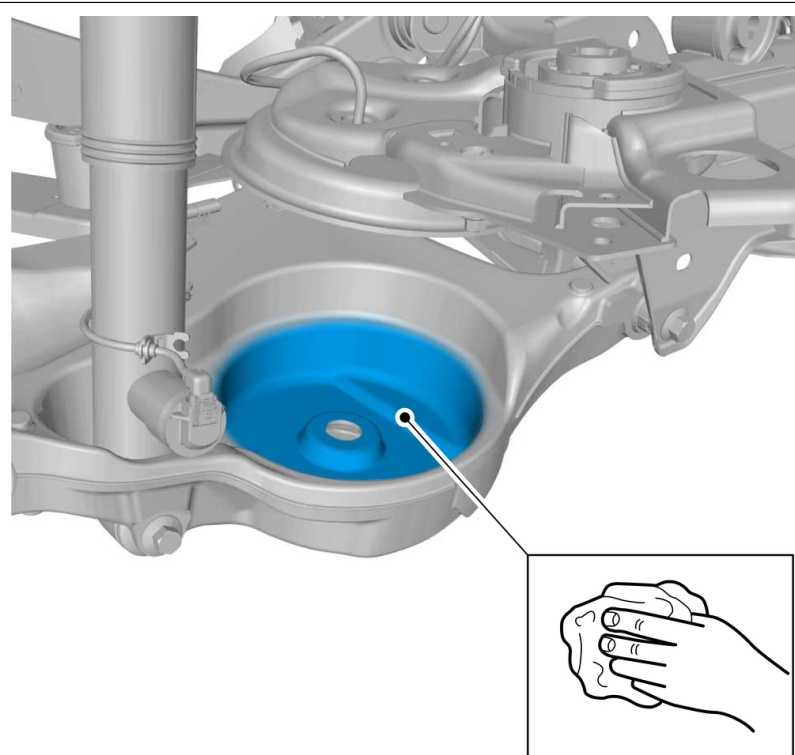

Clean the marked area.

To install, reverse the removal procedure.



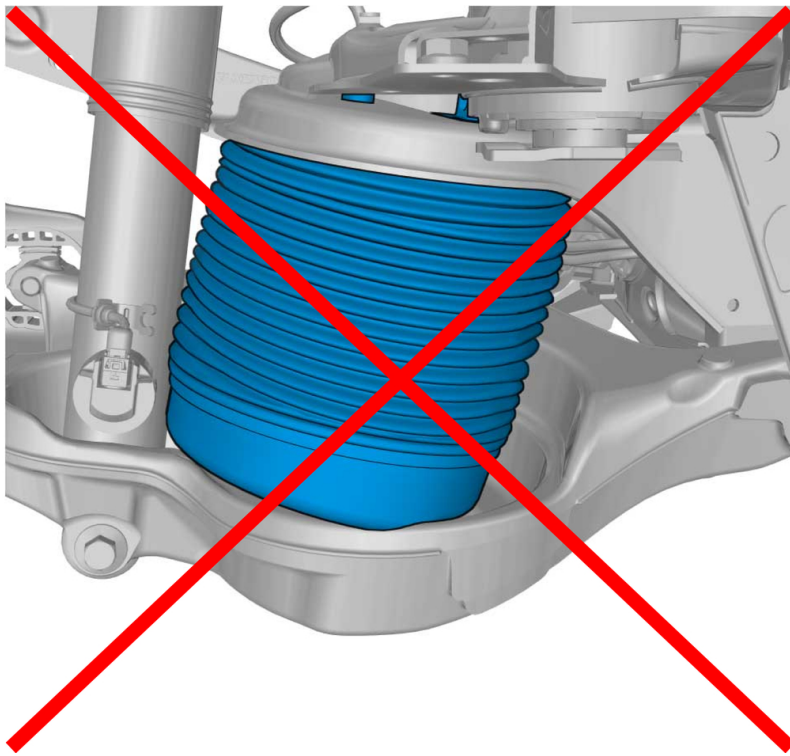

**Note!** Make sure that the component is centred.

Fill air springs according to: Diagnostics/  
Components/ ECU / SUM / Diagnostic  
Sequences / Deflating and filling air springs and  
reservoir

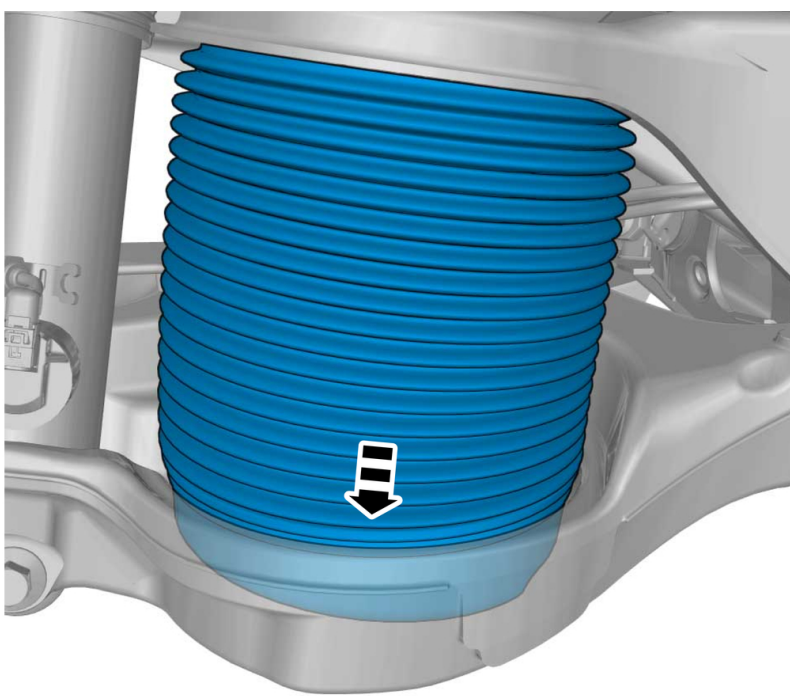

**Warning!** Make sure that the spring is correctly located in the lower spring seat.

Install wheel , refer to:  
Removal, replacement and installation  
7 - Springs and wheels  
77 - Wheels, tyres, hubs  
770 - general

**Caution! Make sure that the air springs are inflated before lowering the vehicle.**