



Technical Service Bulletin

Technical Service Bulletin: TSB190037	Released Date: 13-Mar-2019
External Remote Start Interconnection Wiring Issue between Rental C70D2RE, C100D2RE, C150D2RE, C200D2RE, C275D2RE and Automatic Transfer Switch	

External Remote Start Interconnection Wiring Issue between Rental C70D2RE, C100D2RE, C150D2RE, C200D2RE, C275D2RE and Automatic Transfer Switch

Warranty Statement

The information in this document has no effect on present warranty coverage or repair practices, nor does it authorize TRP or Campaign actions.

Contents

Product Affected

Rental Products:

- C70D2RE
- C100D2RE
- C150D2RE
- C200D2RE
- C275D2RE

Issue

Incorrect wiring of rental generator sets External Remote Start connections with ATS systems.

- Customers/Distributors are incorrectly wiring ATS systems to rental generator sets External Remote Start by using a voltage and/or Ground source from the ATS connection and connecting it to rental generator sets External Remote Start

connections (Dry Contacts Only). Doing this will cause equipment damage and failure.

Verification/Confirmation

The PowerCommand control outputs a 24Vdc signal to Terminal 1 of the external Remote Start Panel. Closing the contacts between Terminal 1 and Terminal 2 will complete the circuit and remotely start the generator set. Closing the contacts between Terminal 1 and Terminal 2 could be done by using a “Dry Contact” circuit with a remote start switch, transfer switch, or other similar devices. Applying any voltage and/or Ground to Terminal 1 or Terminal 2 will cause equipment damage and failure

Resolution

Removal of the Jumper at TB2-2 on the ATS Interconnection Terminal will convert the circuit into a “Dry Contact” state. Instructions for Interconnection wiring of ATS systems and Rental generator sets has been created to insure correct and proper wiring are being performed.

Service Instructions

How to properly connect the Remote Start System between Cummins' ATS and Rental Products

(Only use this layout for Rental and ATS systems)

ATS Terminal Block Interconnection to Rental Generator Set PCC 1302 and PC 3.3 Control Board

1. Please refer to your current ATS Service Manuals - Interconnection Diagram.

ATS Terminal Block Interconnection to Rental Generator Set External Remote Contacts

1. Ensure that **NO JUMPER** connections are between TB2-2 and TB2-1/TB2-3. Remove jumper if present. Failure to do so will cause equipment damage and failure.

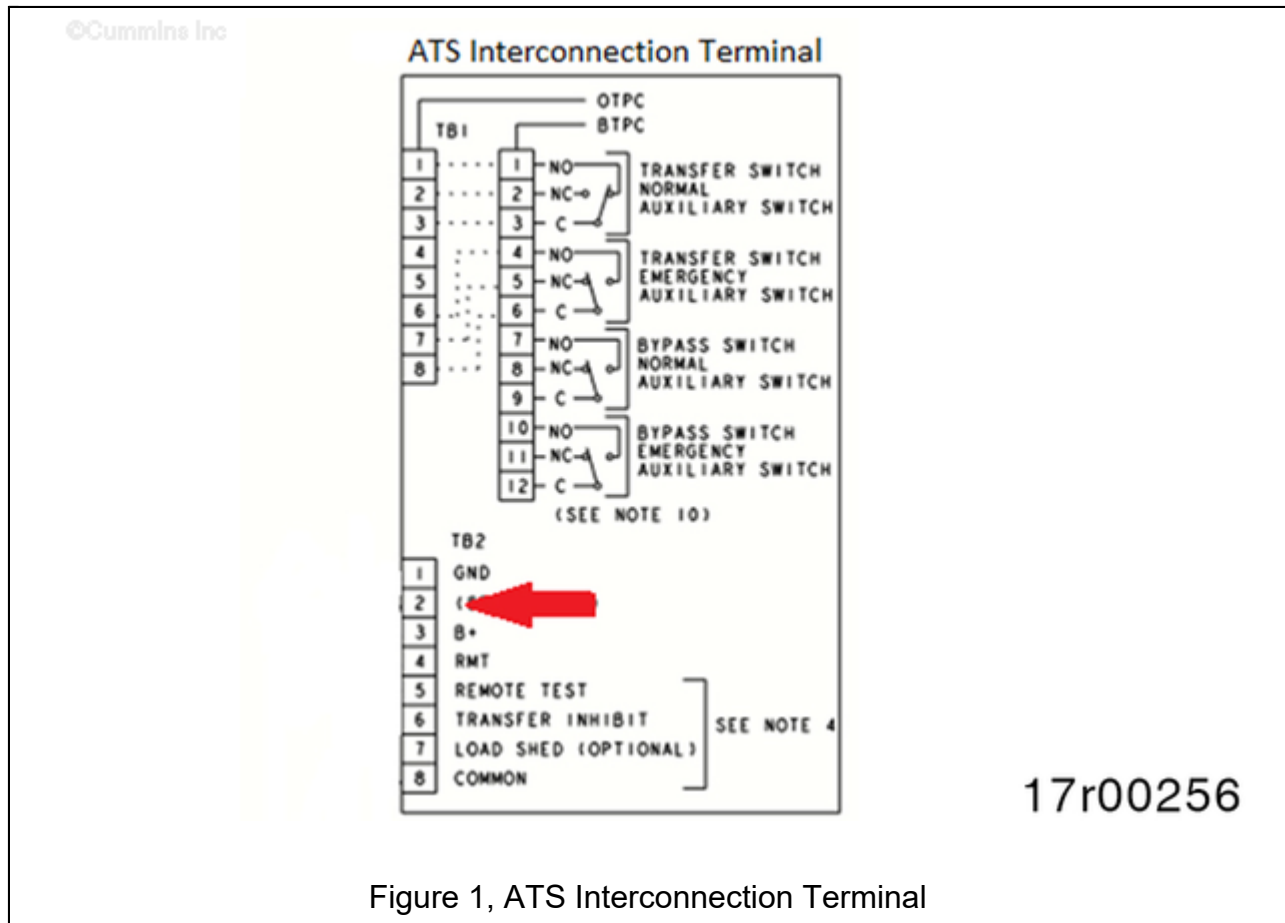

17r00256

Figure 1, ATS Interconnection Terminal

2. Route wire from TB2-2 and TB2-4 from the ATS Interconnection Terminals to the external Remote Start connection terminals found on the Rental generator set control box panel.

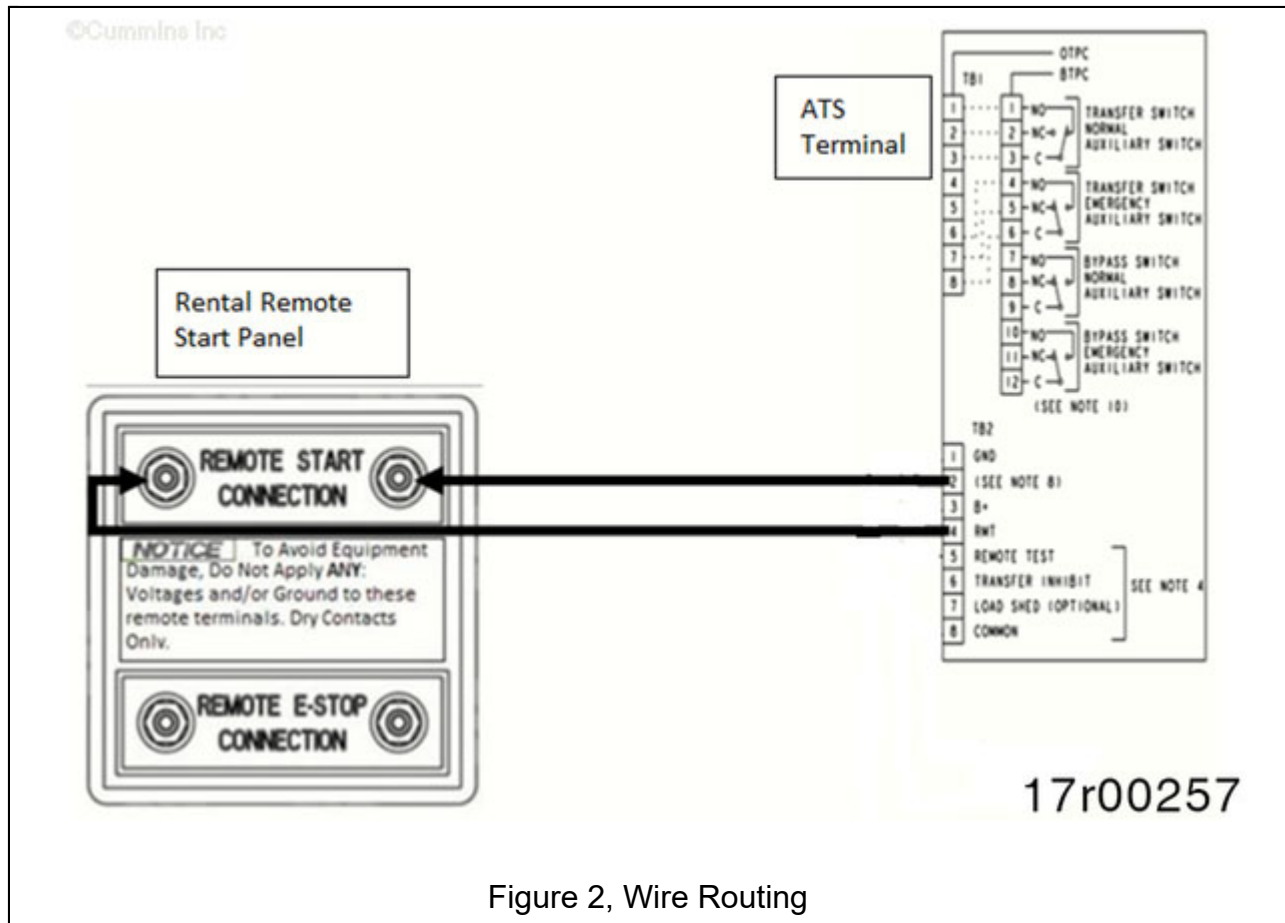

Document History

Date	Details
2019-3-7	Module Created

Last Modified: 13-Mar-2019
