

May 29, 2019

Version 4

MIL Comes On with DTC P0300—P0306 or P219A/B

Supersedes 18-025, dated April 6, 2019. See REVISION SUMMARY.

AFFECTED VEHICLES

Year	Model	Trim	VIN Range
2018	Odyssey	ALL	ALL
2019		ALL	From VIN 5FNRL6...KB000001 thru 5FNRL6...KB026674
2016—18	Pilot	ALL	ALL
2019		2WD ALL	From VIN 5FNYP5...KB000001 thru 5FNYP5...KB001450
		AWD ALL	From VIN 5FNYP6...KB000001 thru 5FNYP6...KB006305
2017—18	Ridgeline	ALL	ALL
2019		2WD ALL	From VIN 5FPYK2...KB000001 thru 5FPYK2...KB002884
		AWD ALL	From VIN 5FPYK3...KB000001 thru 5FPYK3...KB012495

NOTE

The vehicle must have at least **5,000 miles or more** on the odometer.

REVISION SUMMARY

This bulletin has been extensively revised. American Honda recommends that you thoroughly read it.

SYMPTOM

The MIL comes on with DTC P0300 (random misfire detected), and/or P0301—P0306 (cylinder misfire detected), or P219A/B (air-fuel ratio variation of cylinder [bank 1, rear bank/bank 2, front bank]).

PROBABLE CAUSE

Debris from the high pressure pump or the fuel injector machining process can cause internal wear or clogging inside the injector.

CORRECTIVE ACTION

Replace the fuel injectors.

CUSTOMER INFORMATION: The information in this bulletin is intended for use only by skilled technicians who have the proper tools, equipment, and training to correctly and safely maintain your vehicle. These procedures should not be attempted by "do-it-yourselfers," and you should not assume this bulletin applies to your vehicle, or that your vehicle has the condition described. To determine whether this information applies, contact an authorized Honda automobile dealer.

PARTS INFORMATION

Part Name	Part Number	Quantity
Fuel Injector Set (all except 2019 Pilot Touring and Elite)	16010-RLV-315	1
Fuel Injector Set (2019 Pilot Touring and Elite only)	16010-RLV-306	
Fuel Joint Pipe Set	16012-R9P-315	1
Front Gasket	17055-R9P-A01	1
Rear Gasket	17065-R9P-A01	1
Intake Manifold Gasket	17101-RLV-A01	6
Throttle Body Gasket	17102-RLV-A01	1
EGR Seal	17103-RLV-A01	2
EGR Pipe Gasket A	18716-RB0-G01	1

WARRANTY CLAIM INFORMATION

The normal warranty applies.

NOTE

The vehicle must have at least **5,000 miles or more** on the odometer.

Operation Number	Description	Flat Rate Time	Defect Code	Symptom Code	Template ID	Failed Part Number
121110	Replace the fuel injectors (Pilot, except Touring and Elite).	2.5 hr	08001	03217	A18025A	16010-RLV-305
121110	Replace the fuel injectors (Pilot Touring and Elite only).	2.5 hr	08001	03217	A18025B	16010-RLV-305
121110	Replace the fuel injectors (Odyssey).	2.6 hr	08001	03217	A18025C	16010-RLV-315
121110	Replace the fuel injectors (Ridgeline).	2.2 hr	08001	03217	A18025D	16010-RLV-305

Skill Level: Repair Technician

REPAIR PROCEDURE

1. Remove the fuel injectors. Refer to the service information.
 - 1.1. Relieve the fuel pressure.
 - 1.2. Remove the intake manifold and intake manifold base.
 - 1.3. Remove the high pressure fuel pump cover.
 - 1.4. Remove the fuel rail cover.
 - 1.5. Remove the fuel joint pipe.
 - 1.6. Remove the fuel rail and injector.
 - 1.7. Remove the injectors from the fuel rail.
2. Install the parts in the reverse order of removal. Refer to the service information.
 - 2.1. Install the fuel injectors into the fuel rail.
 - 2.2. Install the fuel rail and fuel injectors into the cylinder head.
 - 2.3. Lubricate the tips of the new fuel joint pipe with polyethylene glycol included in the fuel joint pipe kit.
 - 2.4. Also lubricate the threaded areas of the fuel rails and high pressure fuel pump with polyethylene glycol.

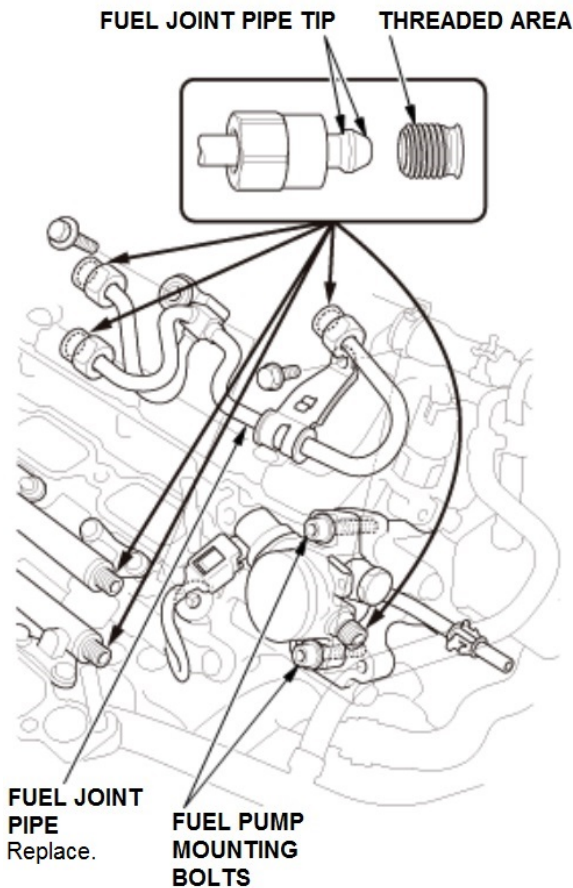

NOTES

- Do not reuse the fuel joint pipe. Failure to install a new fuel joint pipe will cause fuel leaks.
- Before you install the fuel joint pipe, loosen the fuel pump mounting bolts.

- 2.5. Tighten the fuel joint pipe nuts by hand until the tips of the fuel joint pipe are seated on the fuel rails and the high pressure fuel pump.

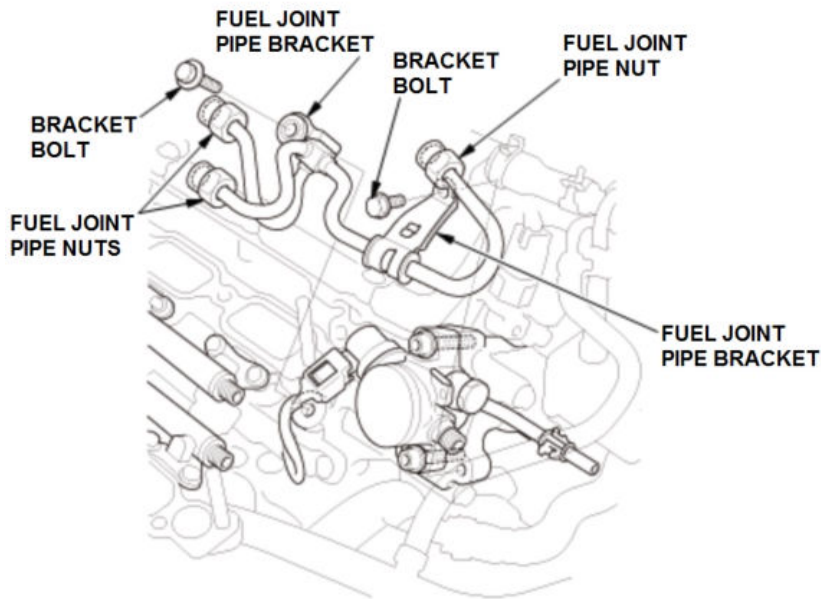

- 2.6. Loosely install the bracket bolts to secure the new fuel joint pipe to the cylinder head.
2.7. Tighten the fuel pump mounting bolts to **25 N·m (18 lb-ft)**.

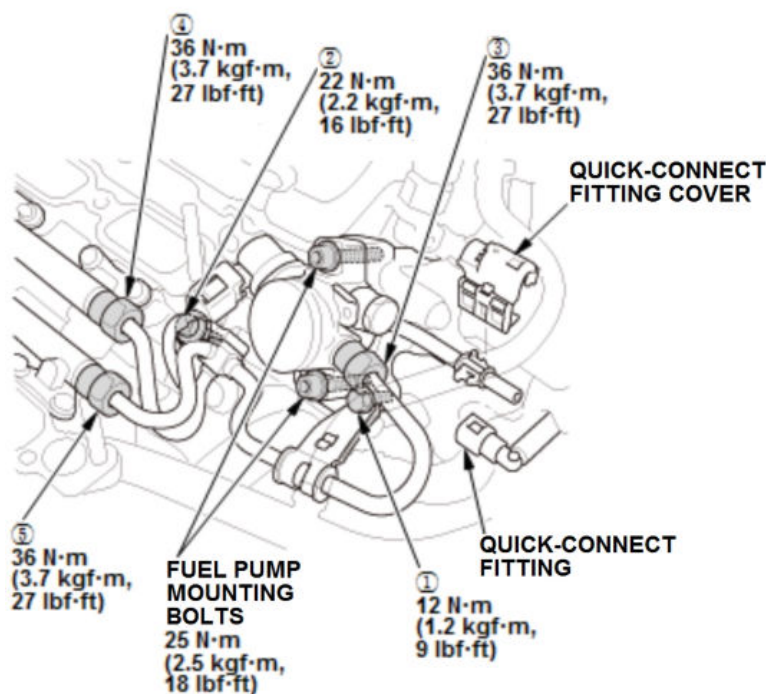

- 2.8. Tighten the fuel joint pipe bracket bolts to **12 N·m (9 lb-ft)** and **22 N·m (16 lb-ft)** in the order shown.
2.9. Tighten the fuel joint pipe nuts to **36 N·m (27 lb-ft)** in the order shown.

NOTES

- A crowfoot-type special tool increases the torque applied by the torque wrench. Refer to Torque Specifications for details on how to recalculate the torque wrench setting.
- Failure to tighten the fuel joint pipe nuts to the proper torque will cause a fuel leak.

- 2.10. Connect the quick-connect fitting and install the quick-connect fitting cover
 - 2.11. Check for fuel leaks.
 - 2.12. Install the fuel rail cover.
 - 2.13. Install the high pressure fuel pump cover.
 - 2.14. Install the intake manifold base and intake manifold.
 3. Do an all DTC check, and clear DTCs from all systems.
- END