

## MAINTENANCE INFORMATION

### MI18-45A

DATE :	November 2018	SECTION :	10 FRONT AXLE
SUBJECT :	Tie Rod 610052; Front I-beam Axle		

Revision: A    General revision.

2019-06-07

### APPLICATION

Model	VIN
All Prevost Model Year: 1994 - 2019	
	Vehicles with I-beam axle S-84 / S-84U

### DESCRIPTION

Vehicles identified above are compatible with a new tie rod design. This new tie rod 610052 has updated ball joints and a fine adjuster sleeve. It replaces former drop type ball joint tie rods. Refer to IS-18091 for installation instructions.

This document details maintenance inspection and toe-in adjustment with the new design tie rod.

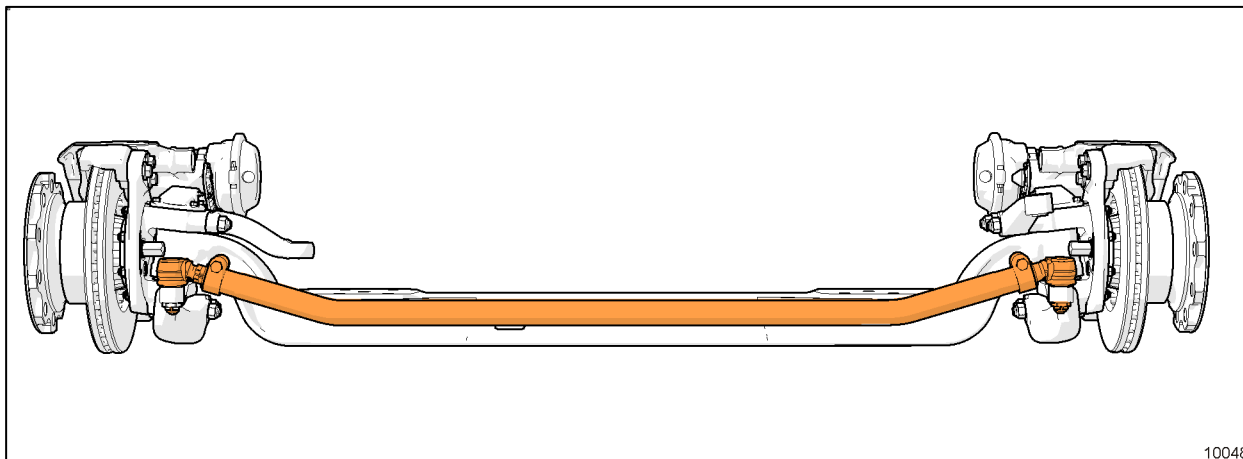

FIGURE 1: 610052 TIE ROD

10048

## TABLE OF CONTENTS

MAINTENANCE INSPECTION .....	3
COMPONENT OVERVIEW .....	3
TUBE INSPECTION .....	3
BALL JOINT INSPECTION.....	4
FINE ADJUSTMENT SLEEVE INSPECTION .....	5
BALL JOINT INSPECTION FOR CORROSION.....	5
TOE IN ADJUSTMENT .....	6
TORQUE REFERENCE .....	6

## MATERIAL

This Maintenance Information pertains to Kit IS18091 which includes the following parts:

Part No.	Description	Qty
610052	TIE ROD ASSY	1
610051	NUT HEX SELF LOCKING M24-1.5 (Single use)	2

## MAINTENANCE INSPECTION PROCEDURES



### MAINTENANCE

Inspect tie rod once a year.



### DANGER

Park vehicle safely, apply parking brake, stop engine. Prior to working on the vehicle, set the ignition switch to the OFF position and trip the main circuit breakers equipped with a trip button. On Commuter type vehicles, set the battery master switch (master cut-out) to the OFF position.

### COMPONENT OVERVIEW

The tie rod features a fine adjustment piece on one side and a standard joint on the other side.

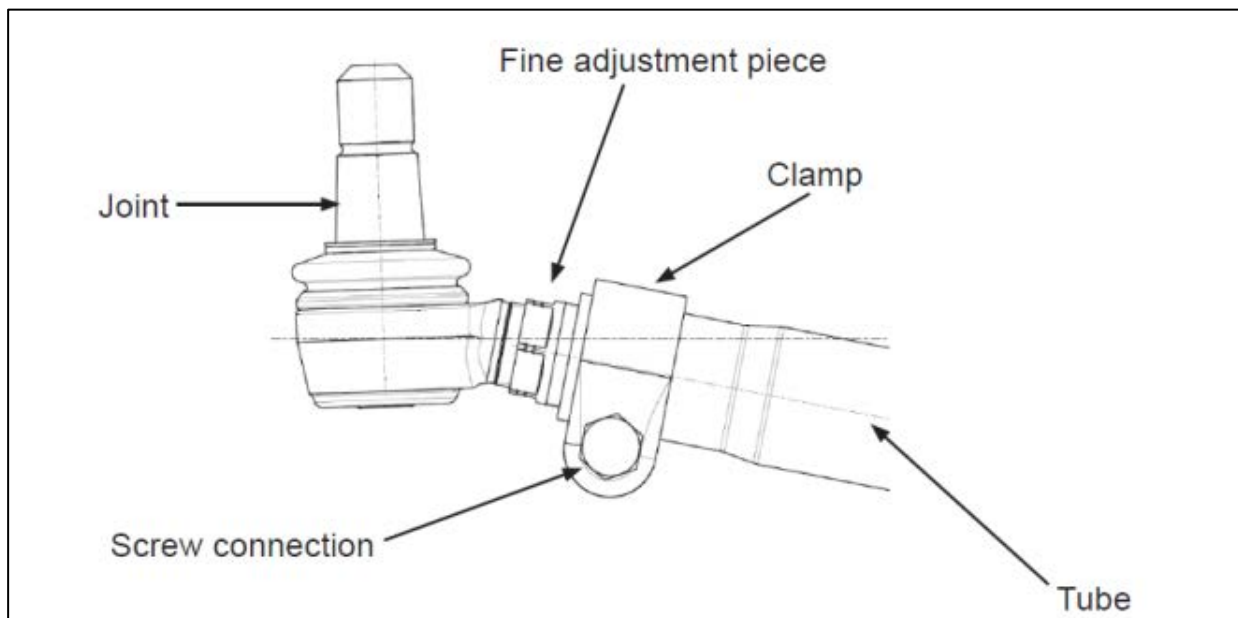

FIGURE 2: TIE ROD COMPONENTS

The steering tie rod requires several visual and functional verifications. If any of the conditions are found, a complete replacement of the tie rod assembly or individual parts may be required.

For additional details, refer to supplier information:

**TRW Front Axle Steering Bar Service Information XSZ143** available on the PrevoSt Technical publications [website](#).

### TUBE INSPECTION

Check the tube for damage. If there are signs of deformation, replace the tie rod assembly.

## BALL JOINT INSPECTION

To inspect joint wear and play, turn the wheels alternately left and right until the wheels move. Perform this with the axle loaded normally. Replace the joint if the movement of the ball stud exceeds **0.5mm axially** in the housing.

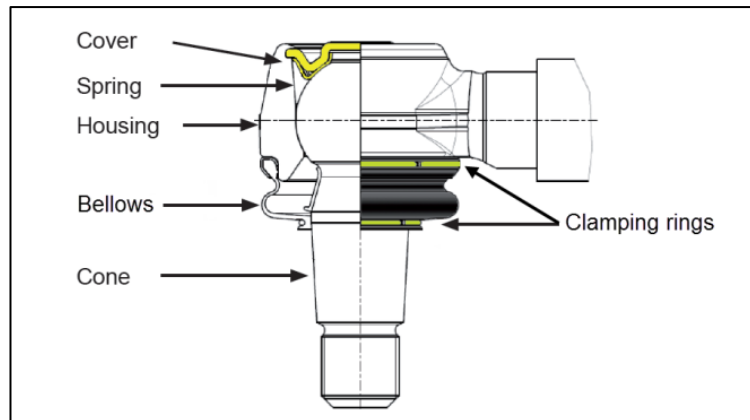

FIGURE 3 TIE ROD BALL JOINT CONSTRUCTION

Measure the distance with a caliper (Figure 4).

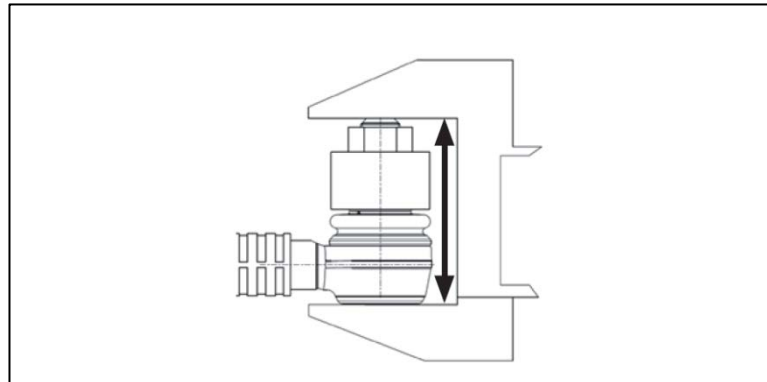

FIGURE 4: MEASURING AXIAL PLAY, TIE ROD JOINTS

## FINE ADJUSTMENT SLEEVE INSPECTION

Turn the wheels alternately left and right while keeping a finger on the threads to feel any movement in the threads (Figure 5).

If there is too much play in the sleeve, replace the tie rod.

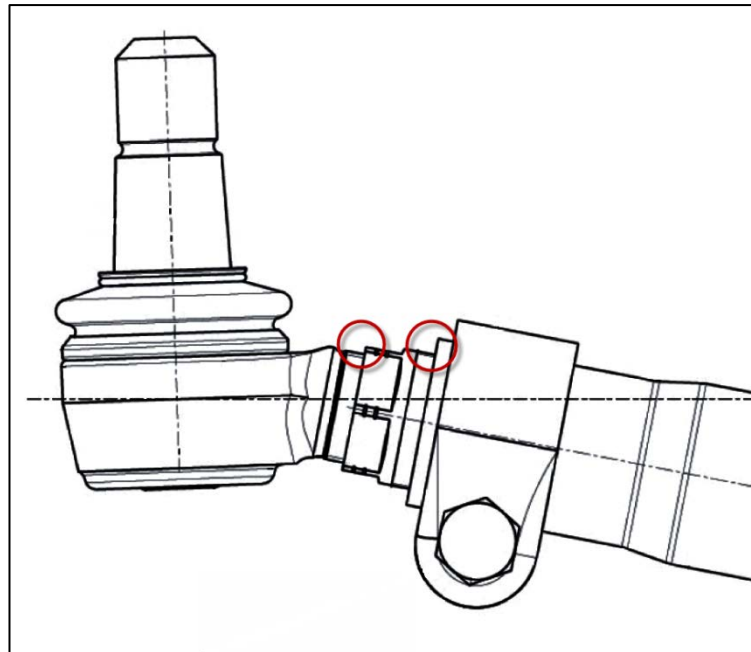

FIGURE 5: FINE ADJUSTMENT SLEEVE INSPECTION

## BALL JOINT INSPECTION FOR CORROSION



### MAINTENANCE

Inspect tie rod ball joints for corrosion once a year.

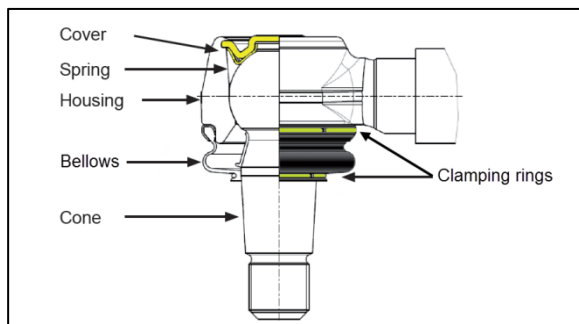

FIGURE 6: TIE ROD BALL JOINT CONSTRUCTION

1. Carefully clean the sealing boot contact area to ensure that no contaminants can get under the sealing bellows during the inspection procedure. Do not use cleaning agents or solvents, only use dry cloth or cotton wool.
2. **Housing:** The housing must not show any signs of deep rusting (depth of no more than approx. 1mm). Pay particular attention to the roll edge and cover, they must be rust free.

Clean corrosion on the axle steering lever contact faces also.

3. **Bellows:** They must be in perfect condition to protect from corrosion. Squeeze the bellows by hand and make sure no grease is expelled from the opening. Make sure the bellows is in good condition, without any holes, tears, scratches or chafing marks. Replace the joint if inspection result is not OK.

Tension rings and clamping rings must be well seated in their groove.

It must always be possible to turn the bellows on the housing by hand (do not use any tools). Hold the bellows in the area of the clamping ring and turn with a lot of manual force. Replace the tie rod if the result is not OK.

## TOE IN ADJUSTMENT

Refer to the maintenance manual for your particular vehicle in *Section 14-Steering* under "Front Wheel Toe-in".

1. If the toe-in measurement is not within the manual's specified tolerance, carry out the following procedure :
  - a. Loosen the pinch bolt on the right hand (curb side) tie rod end where the adjuster sleeve is located.
  - b. Turn the adjuster sleeve (Figure 7) until the specified toe-in measurement is obtained.
  - c. Tighten the pinch bolt nuts

**TORQUE: 107-129 lb-ft (145-175 Nm)**

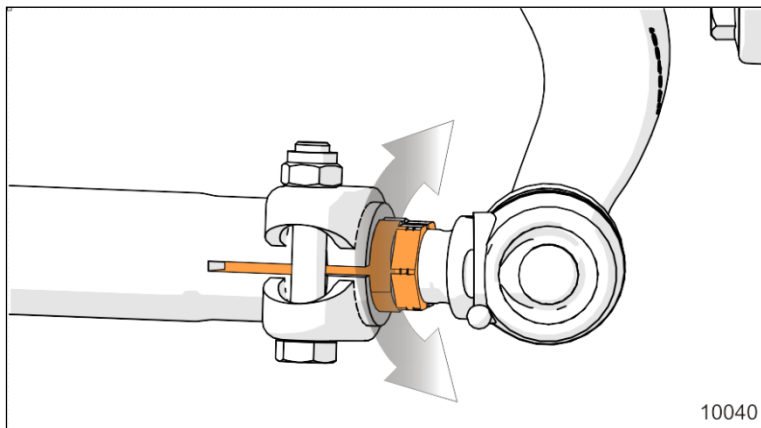

FIGURE 7: FINE ADJUSTER SLEEVE ON TIE ROD

## TORQUE REFERENCE

- (1) Tie rod joint self-locking nuts  
**155-170 lb-ft (210-230 Nm)**

**Note:** Joint nuts are *single use* and should be *replaced every time they are unscrewed*.  
Order 610051 qty 2.

- (2) Tie rod end clamp bolts  
**107-129 lb-ft (145-175 Nm)**

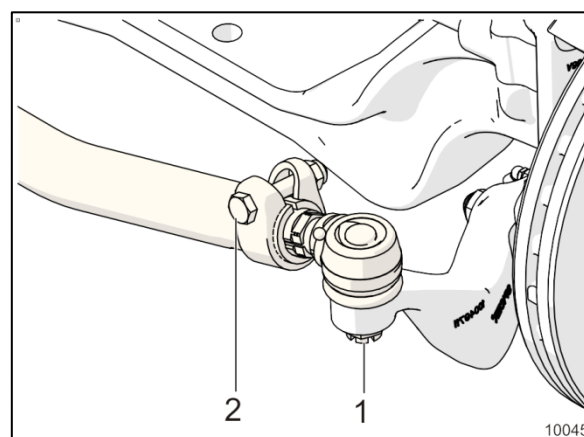

FIGURE 8: 610052 TORQUE REFERENCE

## PARTS / WASTE DISPOSAL

Discard according to applicable environmental regulations (Municipal/State[Prov.]/ Federal)

Access all our Service Bulletins on <http://techpub.prevostcar.com/en/>

Or scan the QR-Code with your smart phone

**Are you a Vehicle owner?**

E-mail us at [technicalpublications\\_prev@volvo.com](mailto:technicalpublications_prev@volvo.com) and type "ADD" in the subject to receive warranty bulletins applicable to your vehicle(s) by e-mail.

