

Technical product information

Topic	Bullseye air outlets - chrome finisher detached
Market area	Bentley: worldwide (2WBE),Hongkong-Macau (5HK)
Brand	Bentley
Transaction No.	2054084/1
Level	EH
Status	Approval
Release date	

New customer code

Object of complaint	Complaint type	Position
air conditioning -> air duct system, filtration, blower -> dash panel air vent	component / consumables -> damaged	
air conditioning -> air duct system, filtration, blower -> centre console air vent	component / consumables -> damaged	

Vehicle data

Bentayga

Sales types

Type	MY	Brand	Designation	Engine code	Gearbox code	Final drive code
4V*	2017	E		*	*	*
4V*	2018	E		*	*	*
4V*	2019	E		*	*	*
4V*	2020	E		*	*	*

Documents

Document name
master.xml

Customer statement / workshop findings

Air vent chrome finisher has detached from vane.



Technical background

It is possible that using aftermarket clip on devices such as mobile phone holders, air freshener holders or chewing gum dispensers may result in the chrome air vent finisher becoming detached from the vane.

Production change

Not applicable.

Measure

Please advise the Customer that the use of aftermarket clip on devices is not recommended and continued use may result in repeat failures. Damage caused by the use of aftermarket clip on devices will not be covered under vehicle warranty.



In the event of a chrome air vent finisher becoming detached from the vane the following procedure should be carried out.

Check the vane or chrome finisher for damage, replace the affected bullseye air outlet assembly if damage is present. The four tabs on the chrome finisher must be present.

Note: Chrome finishers or vanes are not available to order as spare parts

Apply minimal amount of Power Mix 2K or an adhesive with a similar specification, to each of the four tabs on the chrome finisher, insert the vane finisher into the vane ensuring the finisher is located correctly with no gaps.

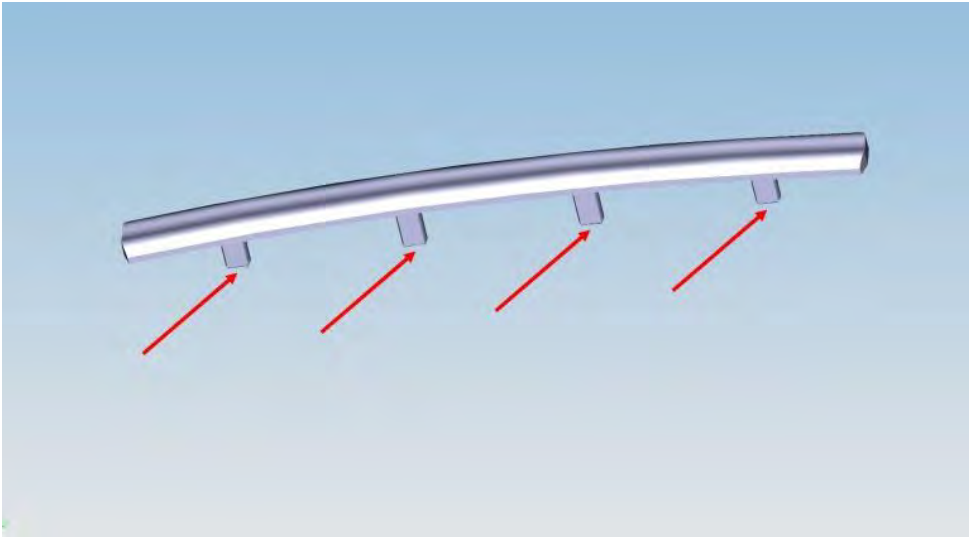

Note: Rotate the vane to the fully down position or fully up position, the vane in this position gives the maximum clearance between the ends of the vane finisher & the bullseye trim ring during re-fitment.

Check the finisher and vent for any residual adhesive, if the adhesive cannot be satisfactorily removed and the appearance of the bullseye assembly is affected then the assembly should be replaced. If required use the Electronic Parts Catalogue (ETKA) for the correct replacement part.

When the adhesive is dry, carry out a 'pull' test to confirm correct bonding of the chrome vane.

Parts information

Part number	Description	Quantity
Locally source	Power Mix 2K	1