

WORK DESCRIPTION FOR FIELD MEASURE

Code: 1809P27C71

Version: 2.0

Correct torque of threaded connection of transmission on engine

Model 205.3/4 and 238 without/with code M005

i Code M005 corresponds to VEHICLE WITH 4MATIC/ALL-WHEEL DRIVE.

Work procedure

1. Remove engine carrier at rear from frame floor assembly.
i For basic data, see AR22.10-P-4360LWB.
2. Lower transmission with transmission jack until threaded connection is accessible.
3. Correct torque of threaded connection (A, Figure 1) of transmission on engine.
i Torque 40 **Nm**.

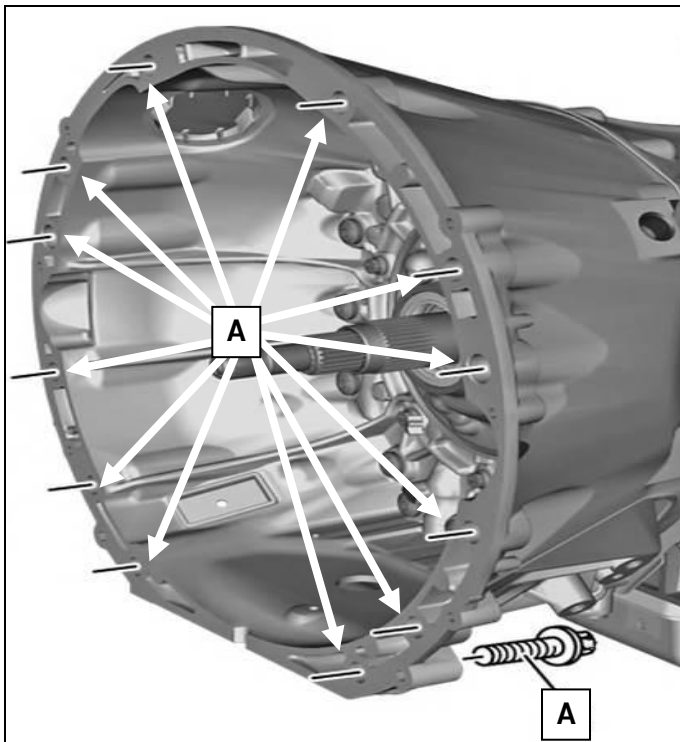

Figure 1

4. Assemble in reverse order.

Operation text and flat rate

Operation no.	Operation text	Flat rate	Accounting no./ damage code
02-2739	Correct torque of threaded connection of transmission on engine Vehicle without code M005	1.1 h	27 900 41
02-2739	Correct torque of threaded connection of transmission on engine Vehicle with code M005	1.4 h	27 900 41

Mercedes-Benz
Global Service & Parts