



---

# SERVICE BULLETIN

---

Classification:	Reference:	Date:
EC19-010	NTB19-052	June 27, 2019

---

## 2016-2018 MAXIMA; LOW POWER / STOP LAMPS STAY ON

**APPLIED VEHICLES:** 2016-2018 Maxima (A36)

### IF YOU CONFIRM

The customer reports that Intermittently there is low power when accelerating,

And/or

The stop lamps (brake lights) stay ON after releasing the brake pedal, with the ignition ON or OFF.

### ACTION

Install the jumper harness from the Parts Information section using the Service Procedure starting on page 2.

**IMPORTANT:** The purpose of ACTION (above) is to give you a quick idea of the work you will be performing. You **MUST** closely follow the entire SERVICE PROCEDURE as it contains information that is essential to successfully completing this repair.

Nissan Bulletins are intended for use by qualified technicians, not 'do-it-yourselfers'. Qualified technicians are properly trained individuals who have the equipment, tools, safety instruction, and know-how to do a job properly and safely. NOTE: If you believe that a described condition may apply to a particular vehicle, DO NOT assume that it does. See your Nissan dealer to determine if this applies to your vehicle.

## SERVICE PROCEDURE

**CAUTION:** Handle interior trim carefully to avoid damage. Work with clean hands and clean tools to avoid dirt and stains. Use protective covers as needed.

1. Record (write down) any customer settings that will be lost when the battery is disconnected.
  - For a listing of the systems that may lose settings or memory when disconnecting the 12V battery refer to the Electronic Service Manual (ESM): **ELECTRICAL & POWER CONTROL > POWER SUPPLY, GROUND & CIRCUIT ELEMENTS > BASIC INSPECTION > INSPECTION AND ADJUSTMENT > ADDITIONAL SERVICE WHEN REMOVING BATTERY NEGATIVE TERMINAL.**
    - This list often includes items such as HVAC, power windows, clock, etc.
2. Turn the ignition OFF.
3. Disconnect the negative terminal of the vehicle 12V battery.
  - For the procedure to disconnect the battery refer to the ESM: **ELECTRICAL & POWER CONTROL > POWER SUPPLY, GROUND & CIRCUIT ELEMENTS > REMOVAL AND INSTALLATION > BATTERY.**

**WARNING:** In the following steps, exposed sharp metal will be present. Take care to prevent personal injury.

4. Remove the stop lamp relay (E34).

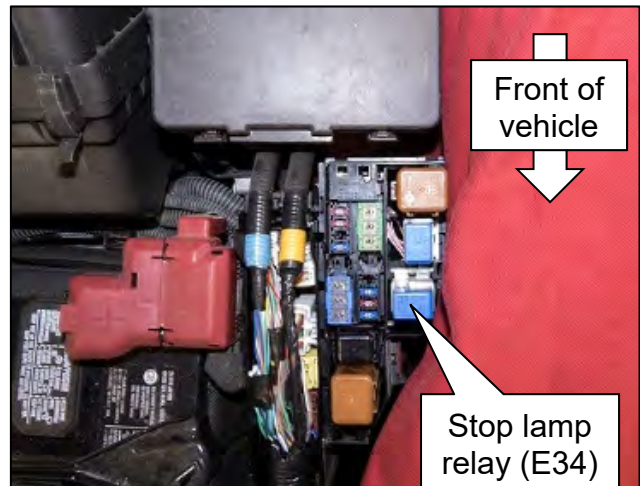

Figure 1

5. Locate Joint Connector-E08 (shown as E39 in Figure 2).

**NOTE:** Joint Connector-E08 is taped to the engine room harness behind the E7 Fuse Block (J/B).

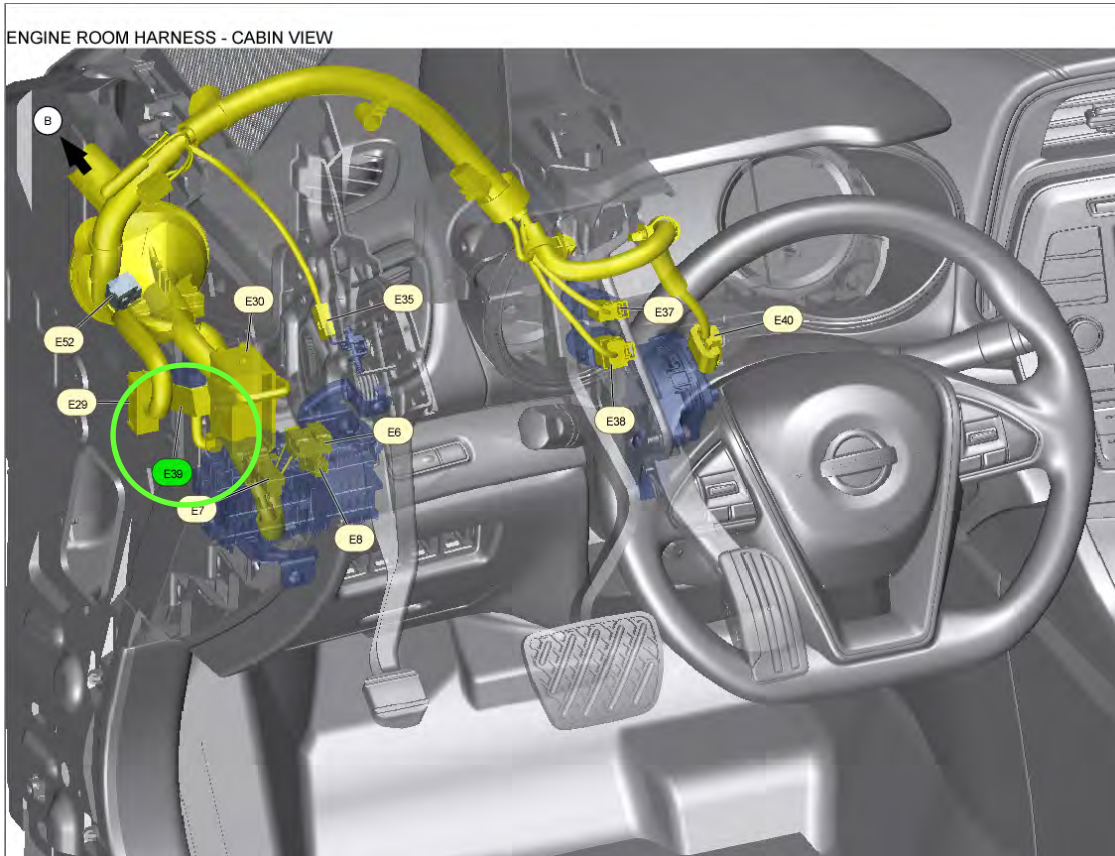

Figure 2

6. Untape Joint Connector-E08 from the engine room harness.

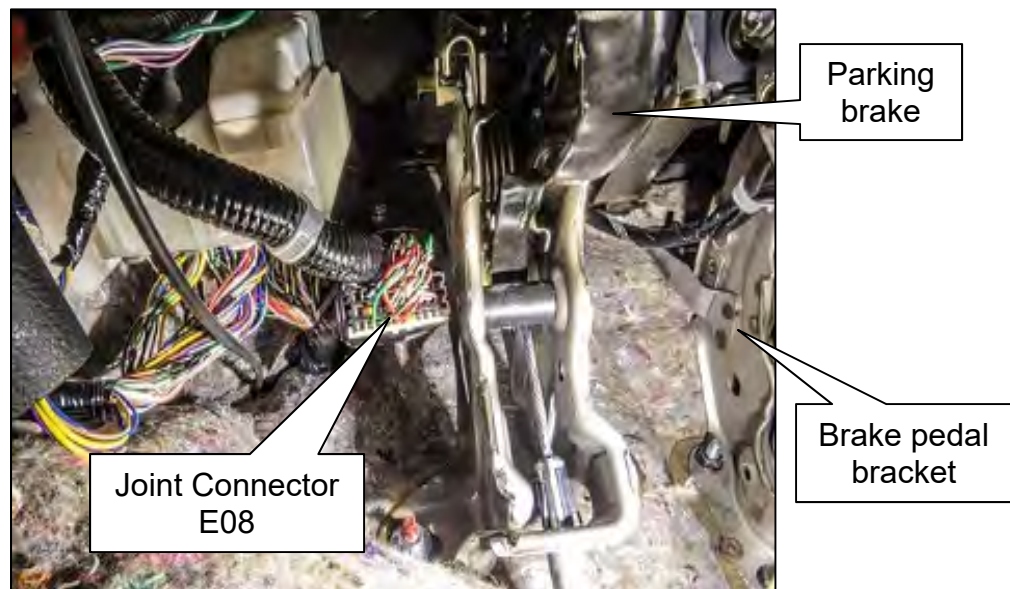

Figure 3

7. Release the harness connector lock tab (Figure 4), and then slide the harness connector lock out (Figure 5) and remove from Joint Connector-E08.

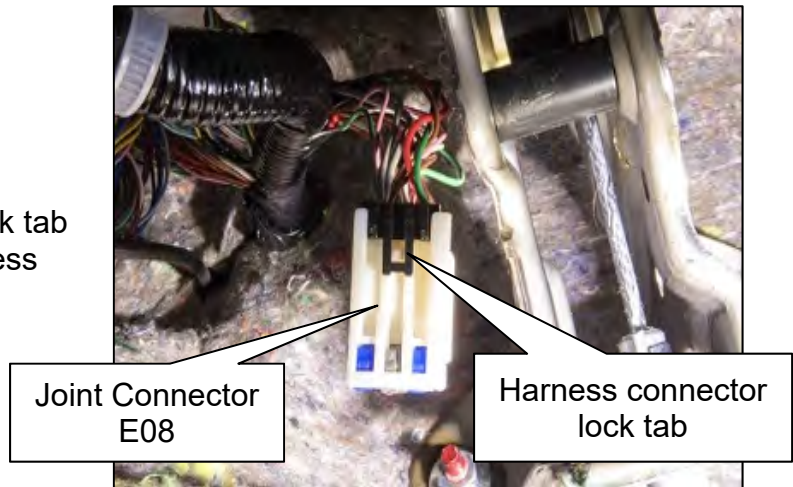

Figure 4

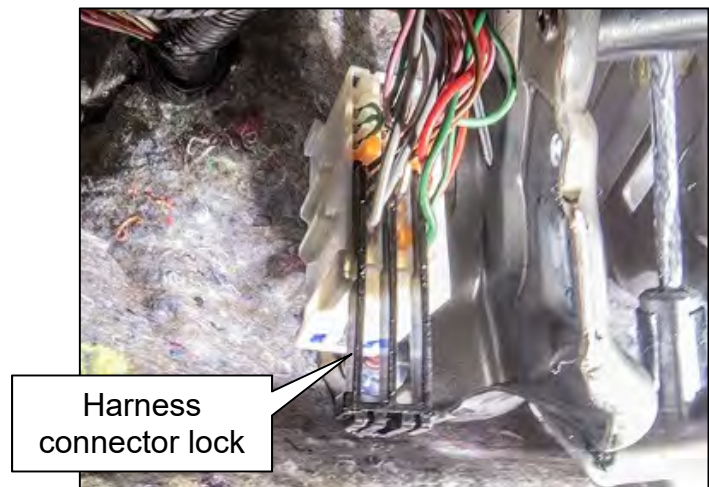

Figure 5

8. Release two (2) locking tabs, one on each side of the grey bus bar (Figure 6 and Figure 7).

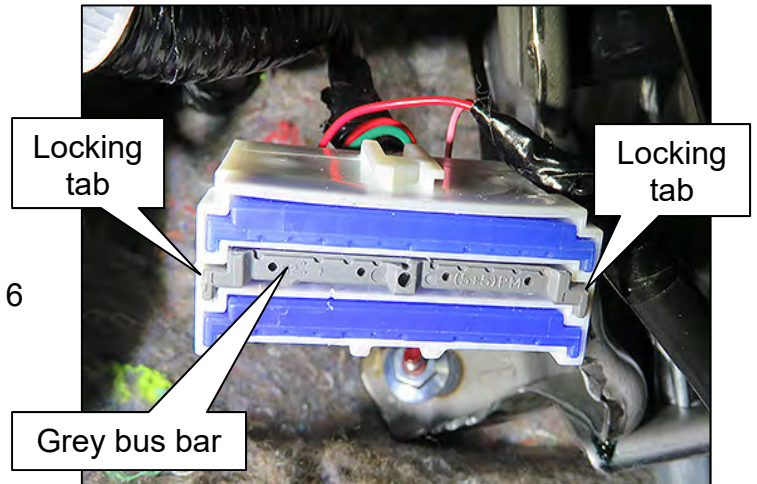

Figure 6

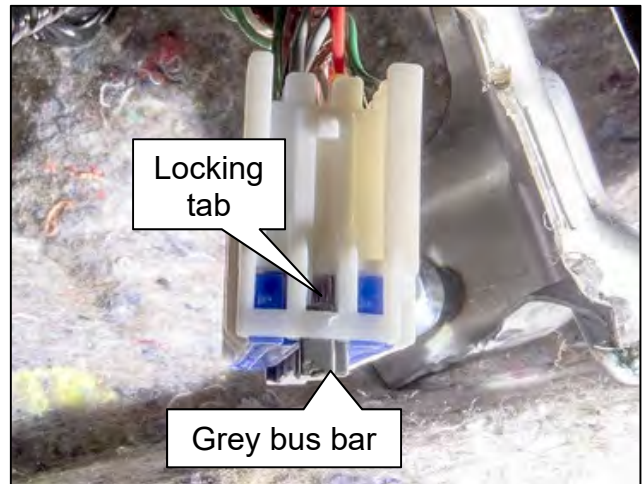

Figure 7

9. Push the bus bar out, and then remove it completely from the connector.

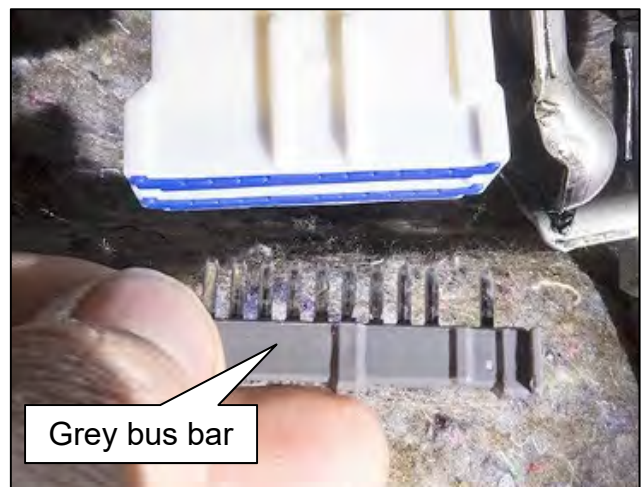

Figure 8

10. Connect a continuity tester to circuit LS01A to the relay circuit where shown in Figure 9.

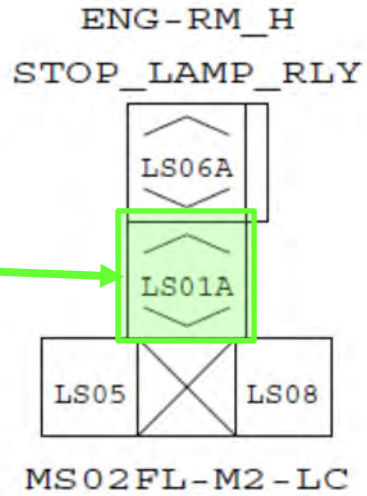
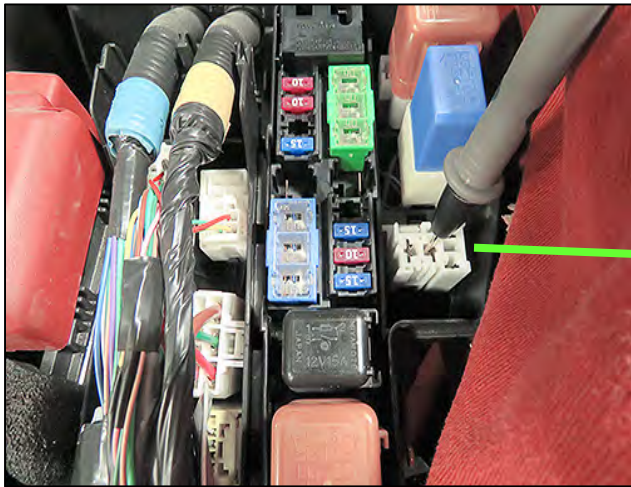

Figure 9

11. Test each of the five (5) Joint Connector-E08 circuits highlighted in Figure 10, as shown in Figure 11, until continuity with LS01A is found.

- The five (5) circuits to be tested all have pink wires.

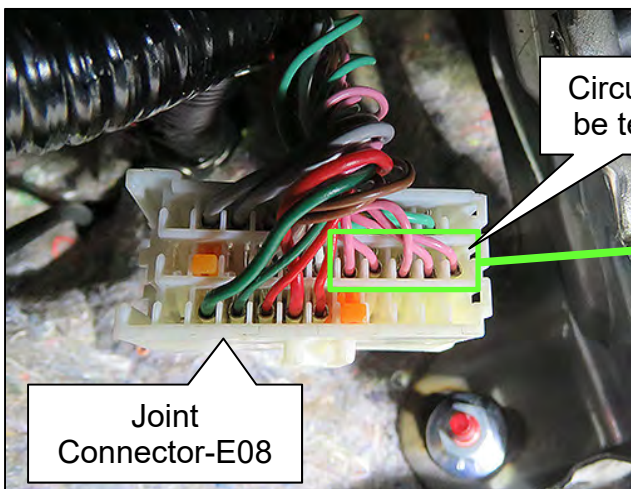

Figure 10

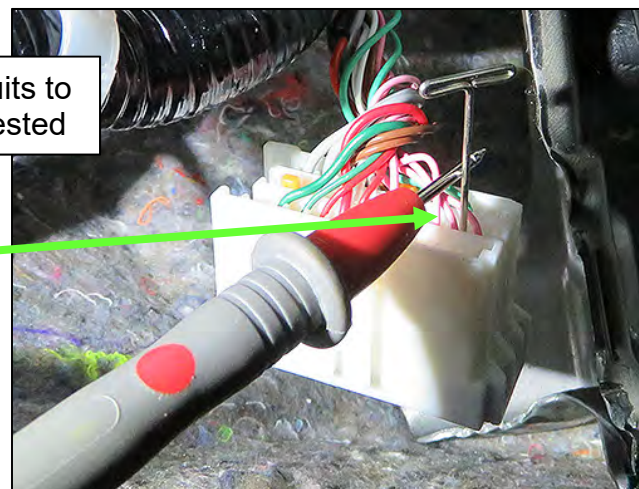

Figure 11

12. Using a terminal tool (J-48817-1, blade #01A), carefully remove the circuit with continuity to LS01A, from step 11.

**NOTE:** Click on the **Video** button at the bottom of the page, for an animation of removing the terminal from Joint Connector-E08.

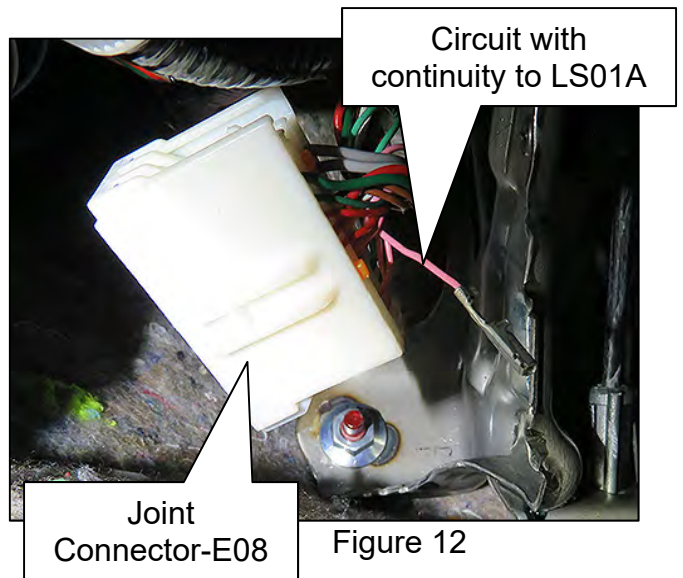

Figure 12

**NOTE:** If needed, refer to **ASIST / Tech-Mate / Tech-Mate Tools & Equipment / Users Guides / Harness Repair Kit Users Guide / S Family** (Page 141) for

13. Cut the terminal off of the removed wire with an appropriate tool.



Figure 13

14. Fold the wire back onto the harness and tape it in place.

- Use 3M/Scotch Professional Grade Vinyl Super 88 Electrical Tape (3/4 inch wide) or equivalent.

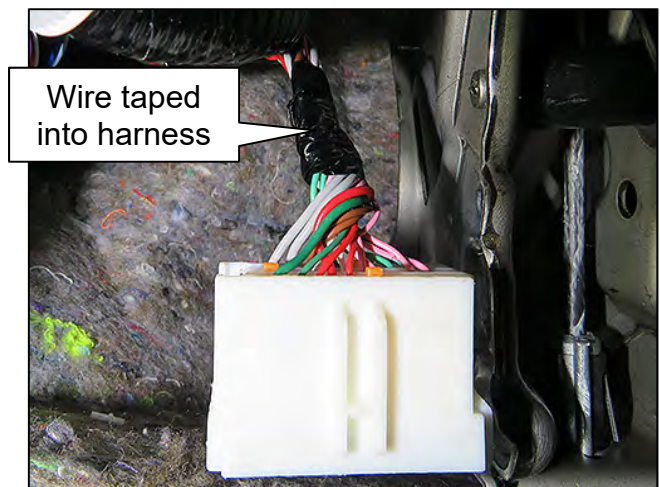

Figure 14

15. Locate the stop lamp switch.

**NOTE:** The original stop lamp switch will be white.

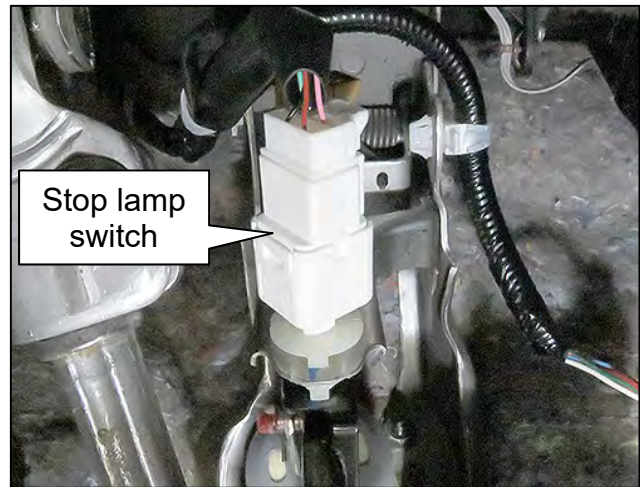

Figure 15

16. Unplug the stop lamp switch harness connector (harness connector E38).

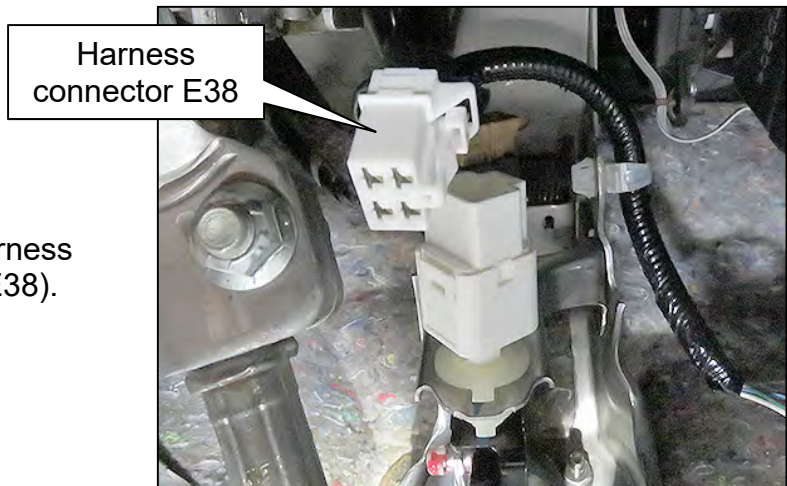

Figure 16

17. Remove the original white stop lamp switch, and then install the new one.

**NOTE:**

- The new stop lamp switch is green.
- See the Parts Information section on page 14.

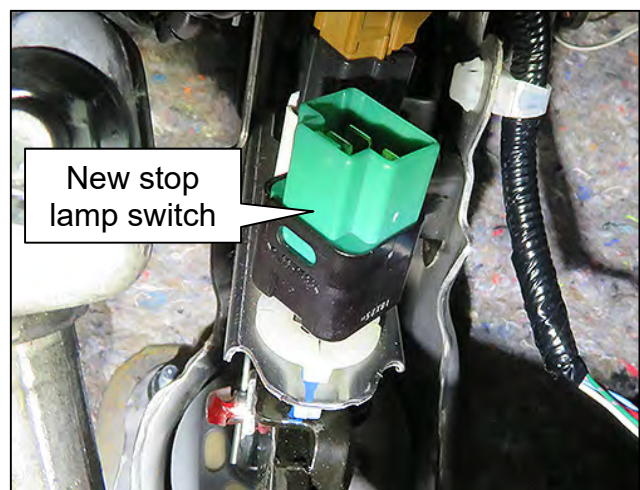

Figure 17

- Refer to the ESM for brake lamp adjustment: **BRAKES > BRAKE SYSTEM > SERVICE DATA AND SPECIFICATIONS (SDS) > SERVICE DATA AND SPECIFICATIONS (SDS)**.



18. Using a terminal tool (J-48817-1, blade #09A), carefully remove the the wires from terminals 1 and 2 from the stop lamp switch connector #E38, shown in Figure 18.

- Terminals Terminal No. 1 and Terminal No. 2 locations are shown in Figure 19, from harness side.

**NOTE:** If needed, refer to **ASIST / Tech-Mate / Tech-Mate Tools & Equipment / Users Guides / Harness Repair Kit Users Guide / MF Family (Page 92)** for the procedure to remove the pins.



Figure 18

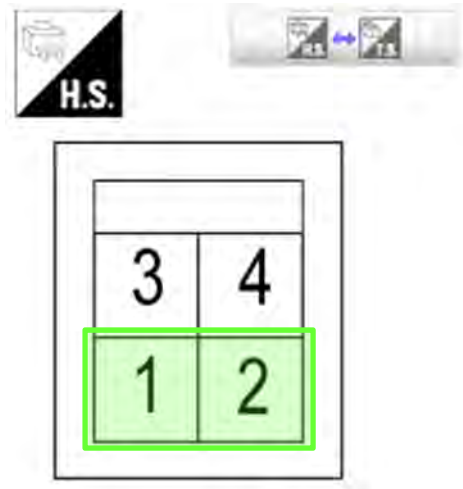

Figure 19

19. Cut the removed wire terminals off with an appropriate tool.

20. Fold the two (2) wires back onto the harness and tape them in place.

- Use 3M/Scotch Professional Grade Vinyl Super 88 Electrical Tape (3/4 inch wide) or equivalent.

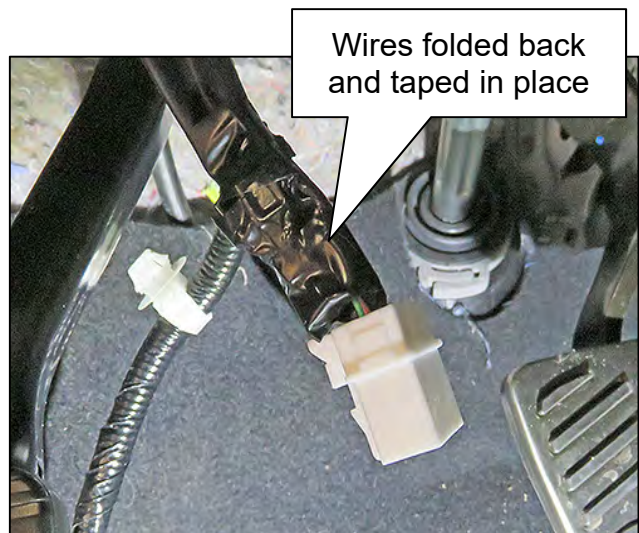

Figure 20

21. Insert the terminal of the pink wire (of the new jumper harness) into the cavity of Joint Connector-E08 where the terminal was removed in step 12.

- See the Parts Information section at the end of this bulletin for the new jumper harness.

22. Insert the terminal of the red wire (of the new jumper harness) into the cavity of Joint Connector-E08 indicated in Figure 21.

**NOTE:** This location is an empty cavity.

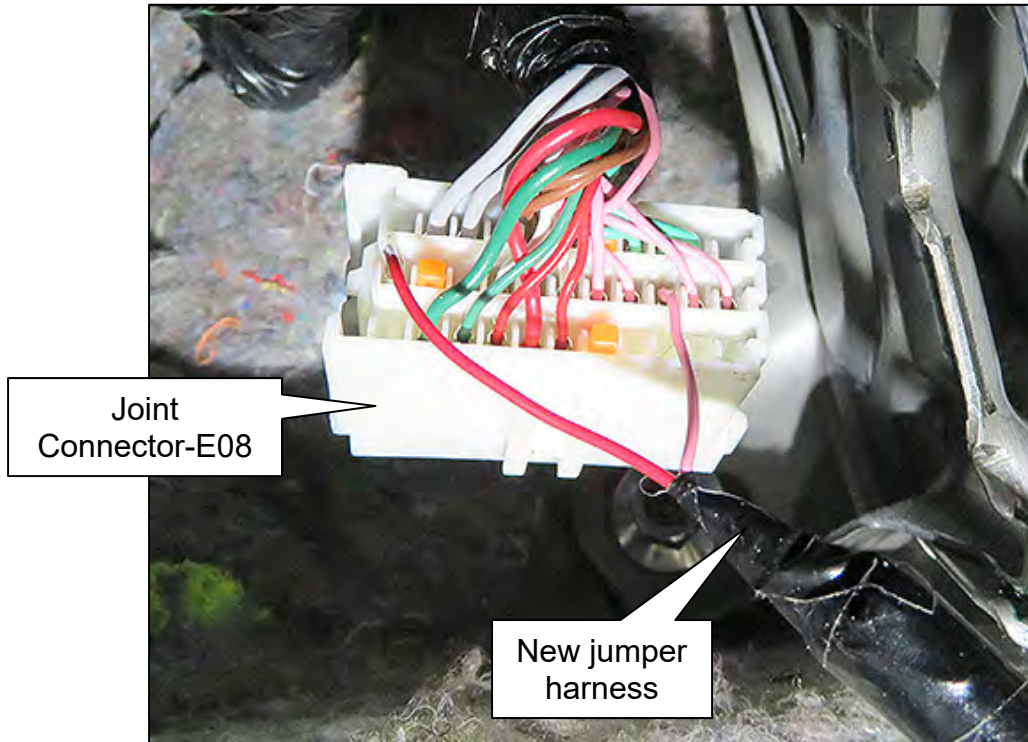

Figure 21

23. Reinsert the grey bus bar into Joint Connector-E08 that was removed in step 9.

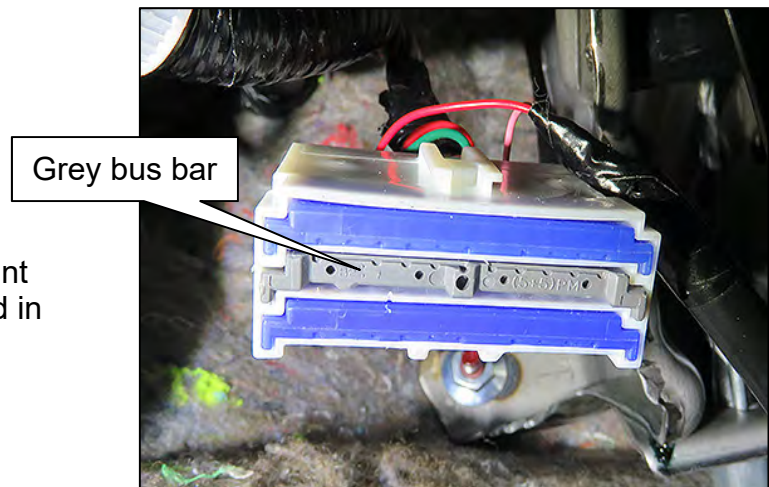

Figure 22

24. Reinstall the harness connector lock that was removed in step 7.

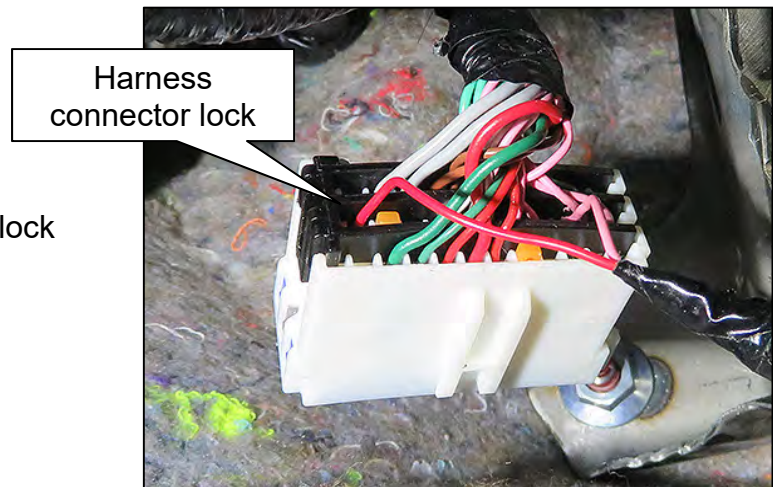

Figure 23

25. Tape or zip tie Joint Connector-E08 back to the harness where it was removed in step 6.

26. Route the new jumper harness along the engine room harness as shown in Figure 24.

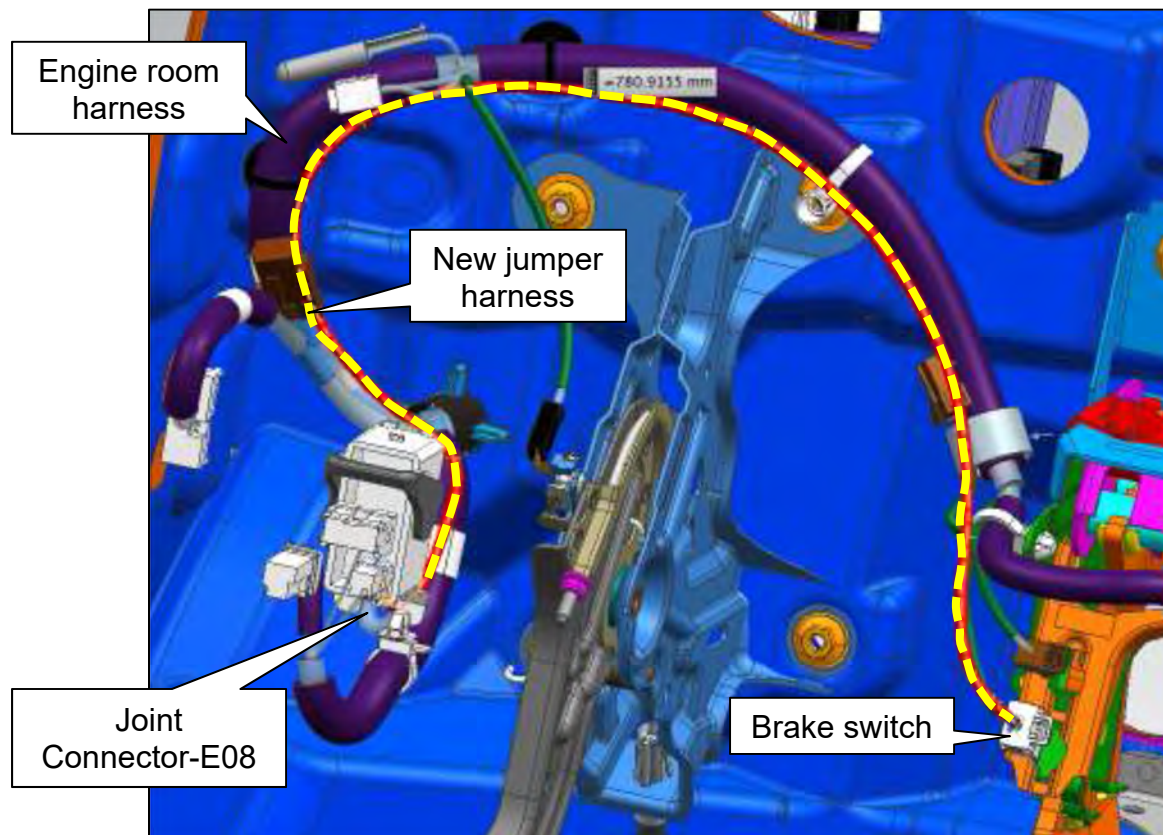

Figure 24

27. Insert the wire terminals of the new jumper harness into the stop lamp switch harness connector (E38).

- Red wire into terminal cavity No. 1.
- Pink wire into terminal cavity No. 2.

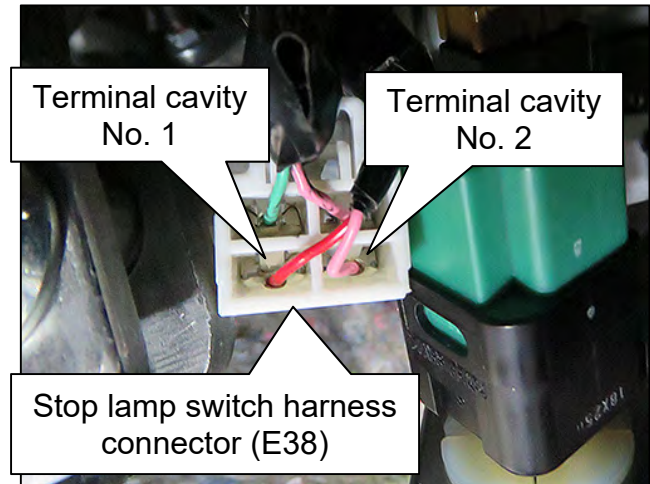

Figure 25

28. Plug the stop lamp switch harness connector (harness connector E38) into the new stop lamp switch.

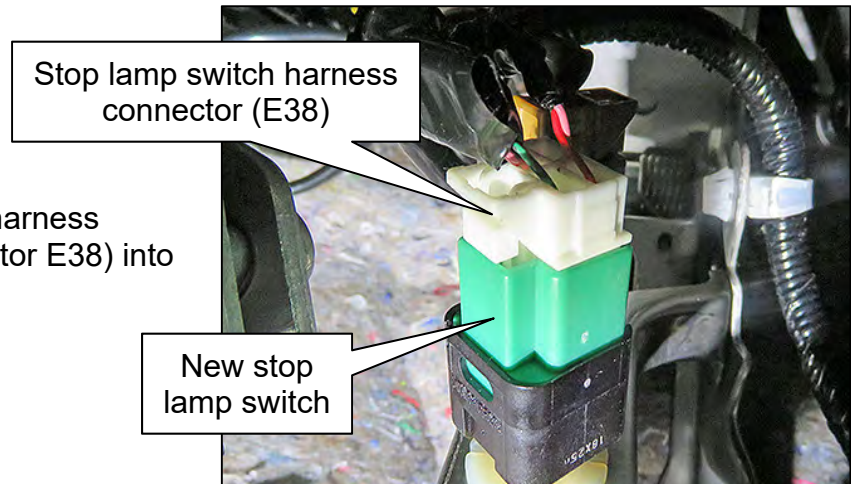

Figure 26

29. Attach the jumper harness with zip ties to the engine room harness as shown in Figure 27.

- Use as many zip ties as needed, to ensure that there is no interference with the surrounding components.

**NOTE:** Extra harness length can be coiled and zip tied to the engine room harness.

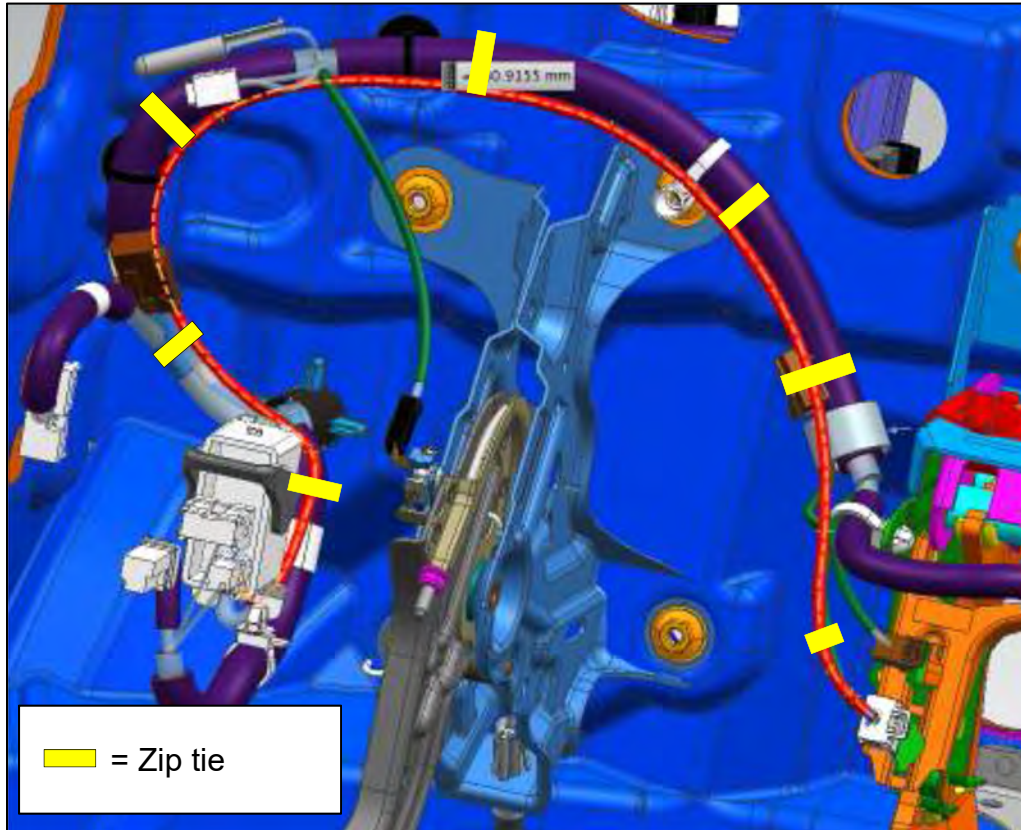

Figure 27

30. Connect the battery negative cable.

31. Confirm that the brake lights function correctly.

32. Reset/reinitialize systems as needed.

- For a listing of the systems that may lose settings or memory when disconnecting the 12V battery refer to the ESM: **ELECTRICAL & POWER CONTROL > POWER SUPPLY, GROUND & CIRCUIT ELEMENTS > BASIC INSPECTION > INSPECTION AND ADJUSTMENT > ADDITIONAL SERVICE WHEN REMOVING BATTERY NEGATIVE TERMINAL.**
  - This list often includes items such as, HVAC, power windows, clock, etc.

33. Test drive the vehicle and make sure it operates correctly and the MIL is OFF.

- This bulletin does not cover any repairs beyond jumper harness installation.
- If the MIL comes ON, go to ASIST for further diagnostic information.

**PARTS INFORMATION**

DESCRIPTION	PART NUMBER	QUANTITY
Jumper Harness (HARNESS-SUB)	24167-4RA9E	1
Brake Switch (SWITCH ASSY-STOP LAMP)	25320-AX10A	1
Zip Ties	(1)	Shop Supply
Electrical Tape	Use 3M/Scotch Professional Grade Vinyl Super 88 Electrical Tape (3/4 inch wide) or equivalent (1)	Shop Supply

(1) This product (or equivalent) is available at many local automotive supply stores, and many local hardware stores.

**CLAIMS INFORMATION**

Submit a Primary Part (PP) type line claim using the following claims coding:

DESCRIPTION	PFP	OP CODE	SYM	DIA	FRT
Install Jumper Harness	(1)	RX8BAA	HC	32	0.8

(1) Reference the electronic parts catalog, and use the Light Relay 25230-\*\*\*\* as the Primary Failed Part (PFP).

**AMENDMENT HISTORY**

PUBLISHED DATE	REFERENCE	DESCRIPTION
June 26, 2019	NTB19-052	Original bulletin published

