



DETROIT[™]
DEMAND PERFORMANCE[™]

**18SP725Rev –Two-Filter Fuel System KM63 GEN2
DD13 High Pressure Fuel Feed Lines, Mounting Bracket
and P-clips Service Kit (P/N: A4710780510)**



WARNING:

PERSONAL INJURY

All parts provided within this kit **MUST** be installed in the proper locations, and **MUST** be fastened to the specified torque. Failure to properly torque hardware/components will result in failure of a high pressure fuel feed line, resulting in possible fire and/or personal injury.



WARNING:

PERSONAL INJURY

All parts provided with this kit, and those they are replacing on the engine, function as a complete system and are single-use items. The old parts cannot be reused. Reusing parts or failing to use all new parts contained in the kit may result in the failure of high pressure fuel lines, possibly resulting in a fire.

NOTICE: Failure to follow these instructions will result in catastrophic damage to the engine and will not be covered under warranty.

KIT DESCRIPTION

This service kit includes all necessary parts to replace the high pressure fuel rail feed lines, mounting bracket, P-clips and mounting hardware in the event one of these parts are loosened, removed or missing from the engine.

KIT CONTENTS

Service kit P/N: A4710780510 contains all of the necessary parts to replace the high pressure fuel feed lines on KM63 Gen2 DD13 engines.

Part No.	Qty.	Description
A4710780310	2	High pressure fuel feed line
A4720700540	2	P-Clip
N000000007957	4	Bolt M6x12mm
A47107001540	1	Mounting bracket
18SP725	1	Installation Instructions

Removal of the High Pressure Fuel Rail Feed Lines - Two-Filter System

Remove as follows:

NOTICE: The high pressure fuel rail feed lines, vibration dampers, P-clips, mounting bracket and hardware are one-time use components and **MUST** be replaced any time they are removed or loosened. Refer to TS letter 16 TS-9 Rev2 (<http://dtna.info/16ts9>) for the high pressure fuel line kit numbers.

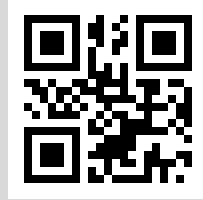

WARNING:

PERSONAL INJURY

To prevent the escape of high pressure fuel that can penetrate skin, ensure the engine has been shut down for a minimum of 10 minutes before servicing any component within the high pressure circuit. Residual high fuel pressure may be present within the circuit.

KM63 GEN2 with Permanent Vibration Dampers

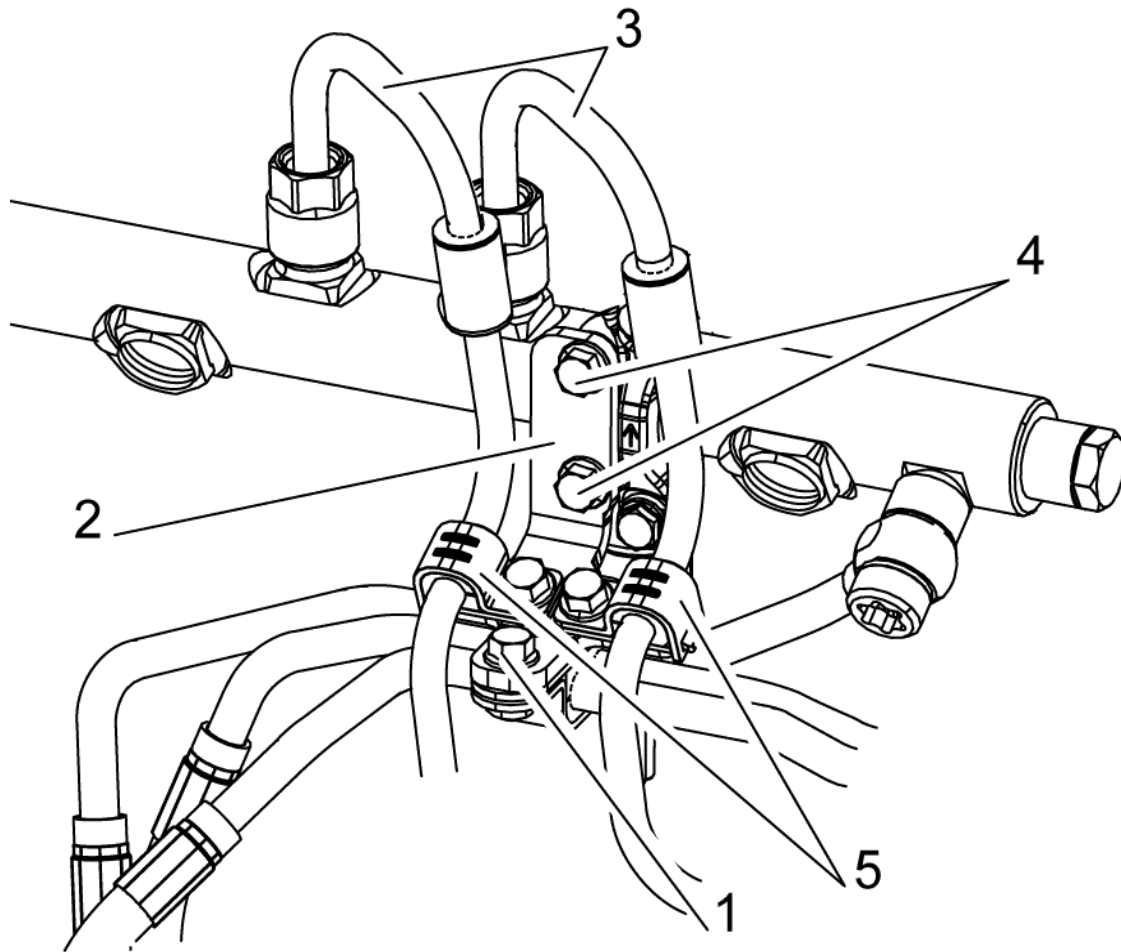

d470251a

Item	Component
1	Reused Return lines P-clip bolt
2	Mounting bracket
3	High pressure fuel feed lines
4	Mounting bracket bolts
5	P-clips and bolts

1. Shut off the engine, apply the parking brake, chock the wheels, and perform any other applicable safety steps.



CAUTION:

ELECTRICAL SHOCK

To avoid injury from electrical shock, use care when disconnecting battery cables. The magnetic switch studs are at battery voltage.

2. Disconnect the batteries.
3. Open the hood.
4. If necessary, remove the bumper. Refer to the Original Equipment Manufacturer (OEM) procedures.
5. If necessary for access, remove the air cleaner. Refer to the (OEM) procedures.

NOTE: Do not discard the return lines P-clip and bolt. It will be reused on the installation of the high pressure fuel rail feed lines.

6. Remove the return lines P-clip bolt (1) from the mounting bracket (2) and save for re-use. See graphic above.
7. Remove and discard the two P-clip bolts from the mounting bracket.
8. Remove and discard the high pressure fuel rail feed lines (3), P-clips (5), and vibration dampers as an assembly from the fuel rail and high pressure fuel pump. See graphic above.
9. Remove and discard the mounting bracket bolts (4) from the fuel rail clamp and discard the mounting bracket (2). See graphic above.

Installation of the High Pressure Fuel Rail Feed Lines - Two-Filter System

NOTICE: The high pressure fuel rail feed lines, vibration dampers, P-clips, mounting bracket and hardware are one-time use components and **MUST** be replaced any time they are removed or loosened. Refer to TS letter 16 TS-9 Rev2 (<http://dtna.info/16ts9>) for the high pressure fuel line kit numbers.



WARNING:

PERSONAL INJURY

All hardware/components **MUST** be installed in the proper locations, and **MUST** be fastened to the specified torque. Failure to properly torque hardware/components will result in failure of a high pressure fuel feed line, resulting in possible fire and/or personal injury.

1. Clean the sealing area inside the high pressure fuel pump outlet fittings using a clean lint-free cloth.

NOTE: The illustration shown below is of KM59 GEN1 High Pressure Fuel Pump Fittings; KM63 GEN2 High Pressure Fuel Pump Fittings are similar.



d470166

2. Clean the sealing area inside the high pressure fuel rail using a clean lint-free cloth.

NOTE: The illustration shown below is a KM59 GEN1 High Pressure Fuel Rail; KM63 GEN2 High Pressure Fuel Rail is similar.



NOTE: Ensure triple clip is present with the top clip (1) inserted into the bottom clip (2) in position; see graphic below.

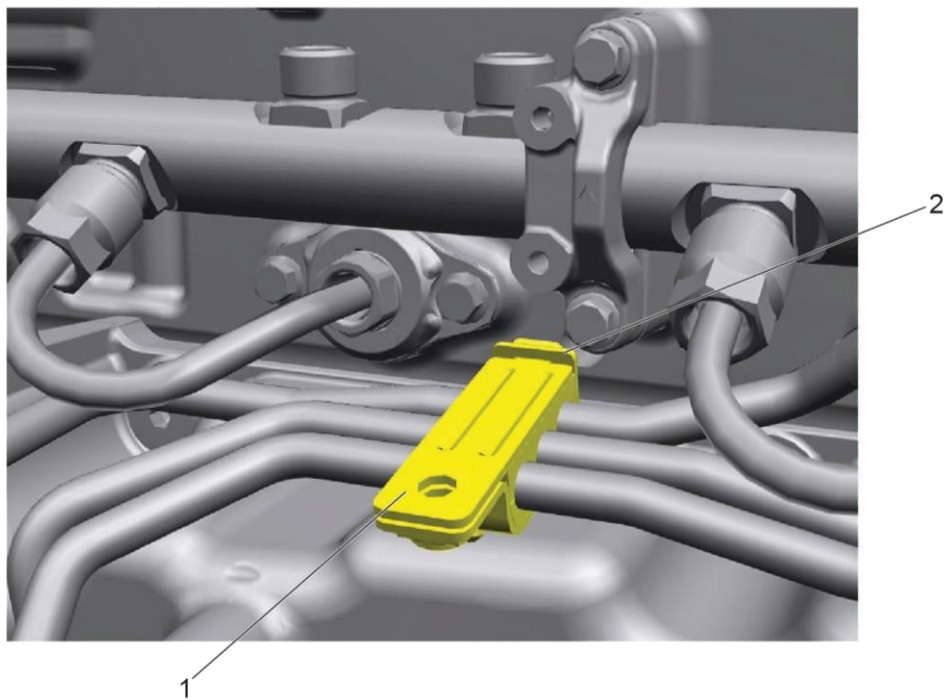

3. Install the new mounting bracket (2) and two new mounting bracket bolts (4) to the fuel rail clamp. Hand-tighten the mounting bracket bolts all the way until the bracket and bolts are flush. Do not torque at this time.

KM63 GEN2 with Permanent Vibration Dampers

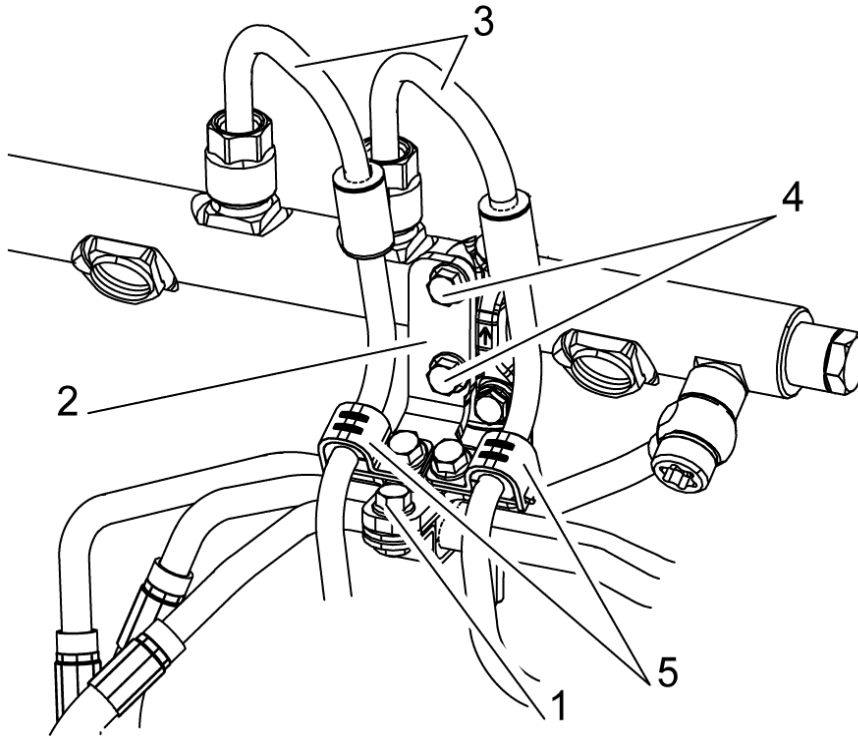

d470251a

NOTICE: New P-clip MUST be installed onto the high pressure fuel rail feed lines with the lower P-clip plate (1) inserted in to the P-clip window (2); see graphic below.

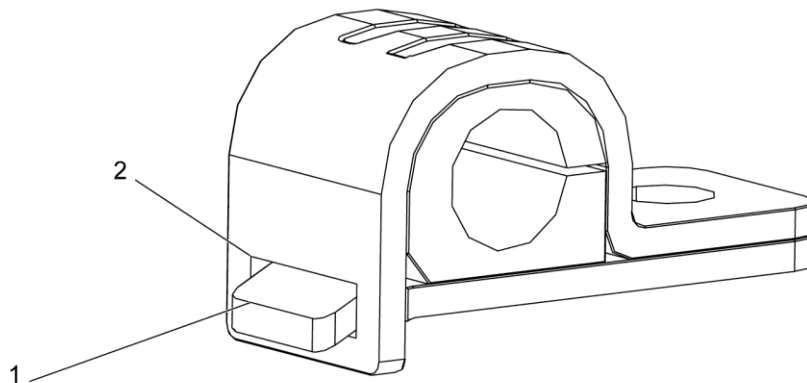

d470247

4. Install both of the new P-clips, one each, onto the high pressure fuel rail feed lines; see graphic below.

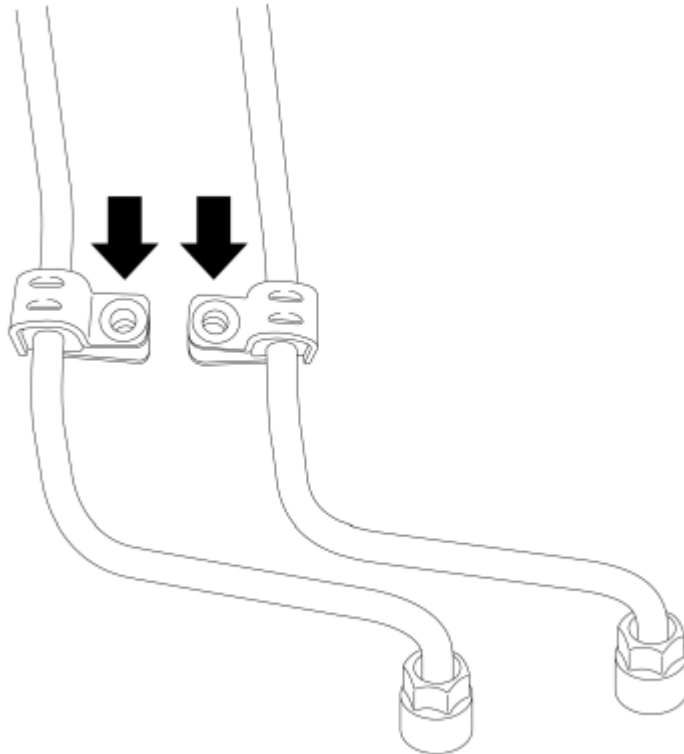

d470315

NOTE: DO NOT use new high pressure fuel rail feed lines that do not have new vibration dampers installed.

5. Position the rear high pressure fuel rail feed line into the fuel rail and the high pressure fuel pump. Start the threads of the fuel line nuts but do not tighten at this point.
6. Position the front high pressure fuel rail feed line into the fuel rail and the high pressure fuel pump. Start the threads of the fuel line nuts but do not tighten at this point.

NOTE: New P-clips (1) **MUST** be installed perpendicular to the bracket (2) and parallel with each other. Hold P-clips in place during tightening to avoid rotation of the P-Clips; see graphic below.

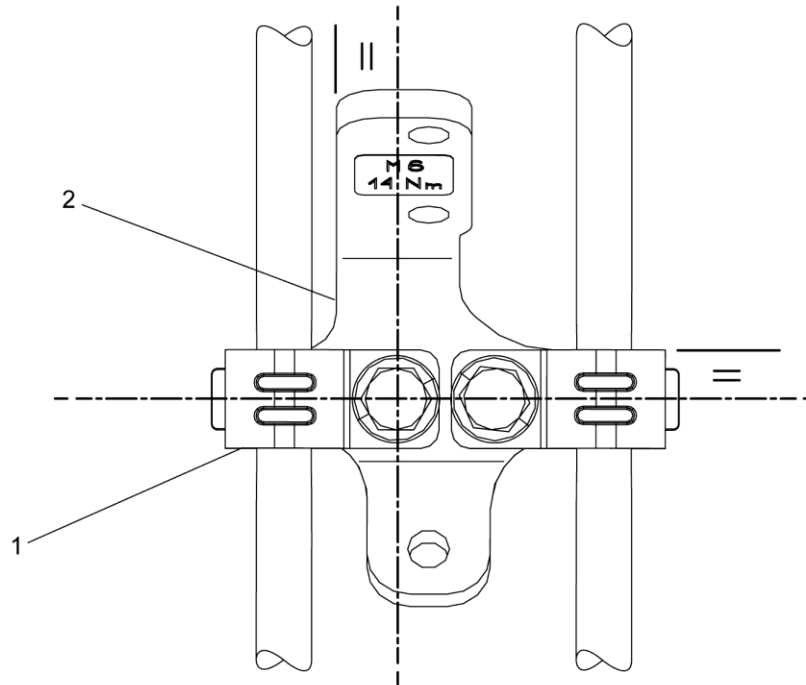

d470318

7. Ensure both of the high pressure fuel rail feed lines are in place so that the P-clip mounting holes line up with the bracket nuts. No excessive force should be applied to any components in the high pressure fuel rail feed lines kit when loosely assembling them.
8. Install the new front and rear P-clip bolts hand tight. Do not torque at this time.
9. Hand-tighten the front and rear high pressure fuel rail feed lines starting with the rail side nut first, and then the nut at the high pressure fuel pump.

NOTICE: After torquing each fuel line nut, P-clip bolt, mounting bracket bolt, and return line triple-clip bolt, mark the fittings and fasteners with a paint pen. Draw a paint line on the fitting or fastener and the adjacent metal as shown in the photograph below.

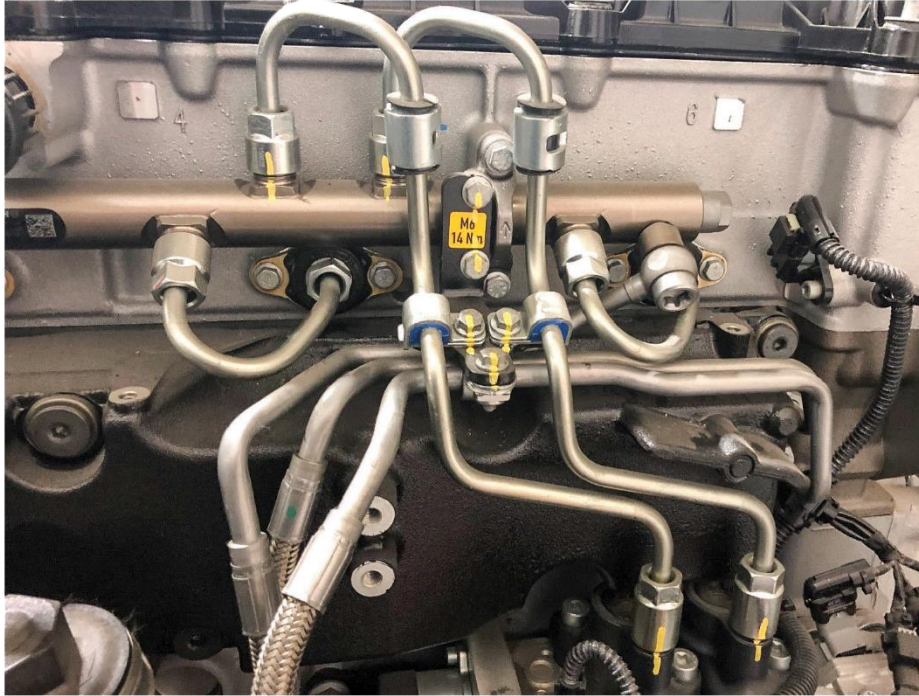

d070174

10. Using fuel line socket W314589010300 or a commercially available 19mm fuel line socket, torque the rear high pressure fuel rail feed line nuts to 40 N·m (30 lb·ft) starting with the rail side nut first, and then the nut at the high pressure fuel pump. Using a paint pen, draw a paint line on the torqued fuel line nut and the adjacent metal, as shown in the photograph above.
11. Using fuel line socket W314589010300 or a commercially available 19mm fuel line socket, torque the front high pressure fuel rail feed line nuts to 40 N·m (30 lb·ft) starting with the rail side nut first, and then the nut at the high pressure fuel pump. Using a paint pen, draw a paint line on the torqued fuel line nut and the adjacent metal, as shown in the photograph above.

NOTE: New P-clips (1) **MUST** be installed perpendicular to the bracket (2) and parallel with each other. Hold P-clips in place during tightening to avoid rotation of the P-Clips.

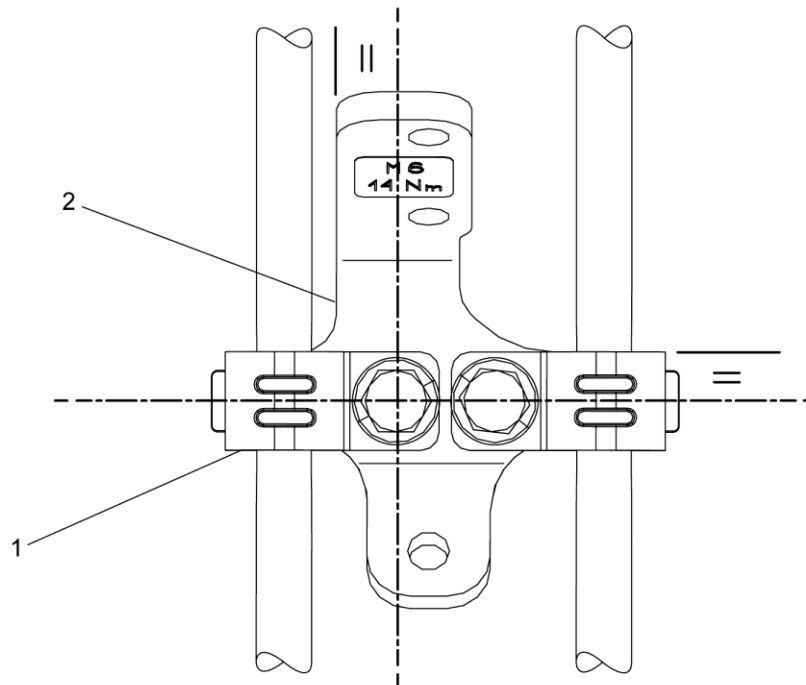

d470318



WARNING:

PERSONAL INJURY

All parts provided within this kit **MUST** be installed in the proper locations, and **MUST** be fastened to the specified torque. Failure to properly torque hardware/components will result in failure of a high pressure fuel rail feed line, resulting in possible fire and/or personal injury.

12. Torque the two new high pressure fuel rail feed line P-clip bolts to 14 N·m (124 lb·in.). Using a paint pen, draw a paint line on the torqued bolt head and the adjacent metal, as shown in the notice after step 9.
13. Using a deep well socket for clearance, torque the two new mounting bracket bolts to 14 N·m (124 lb·in.). Using a paint pen, draw a paint line on the torqued bolt head and the adjacent metal, as shown in the notice after step 9.
14. Install the bolt for the amplification, needle, and pressure limiting valve return line triple-clip (1); see graphic below. Torque to 14 N·m (124 lb·in.). Using a paint pen, draw a paint line on the torqued bolt head and the adjacent metal, as shown in the notice after step 9.

KM63 GEN2 with Permanent Vibration Dampers

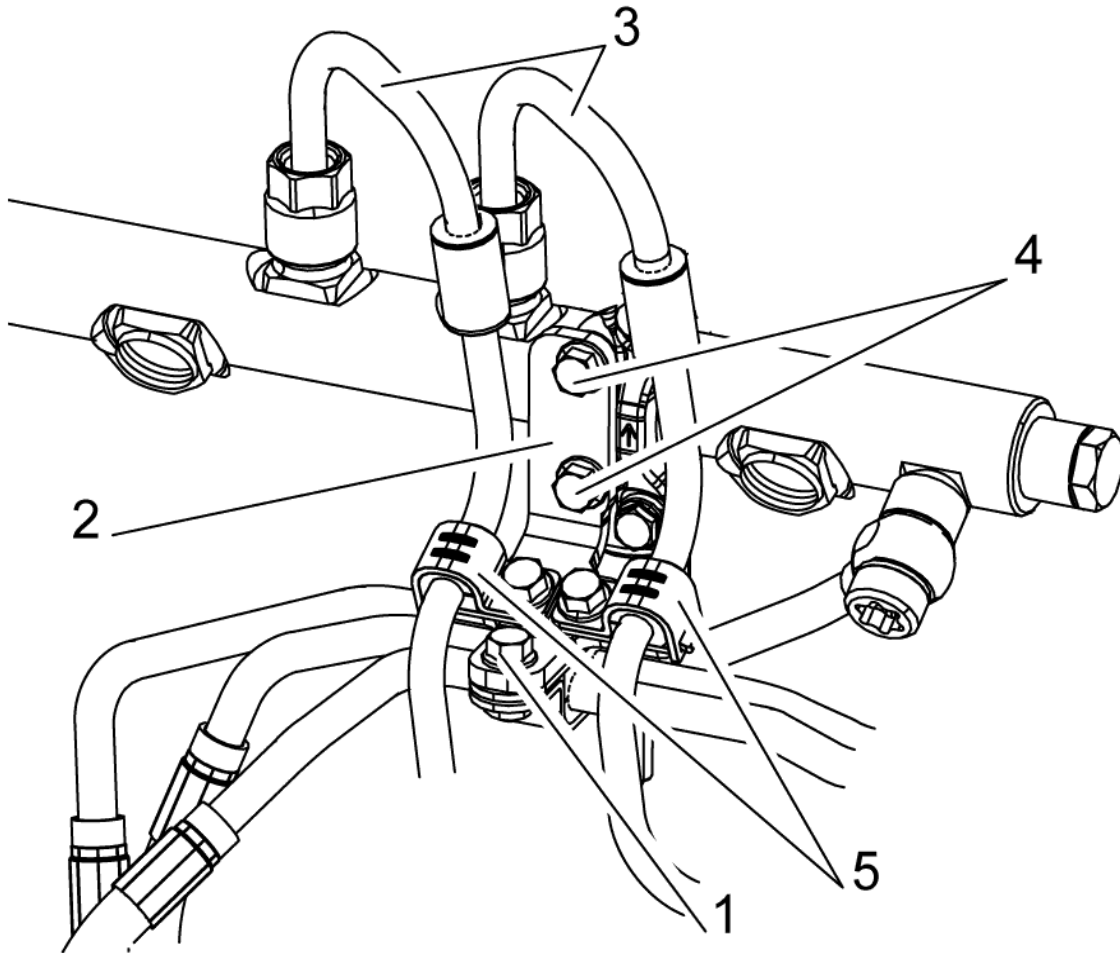

d470251a

15. Inspect all components of the high pressure fuel rail feed line kit to make sure all fittings and fasteners have been properly installed, torqued and marked with a paint pen. Have the lead hand or supervisor review the installation and sign off on the repair order to ensure that all components were properly torqued and painted.
16. If removed for access, install the air cleaner. Refer to the Original Equipment Manufacturer (OEM) procedures.



CAUTION:

ELECTRICAL SHOCK

To avoid injury from electrical shock, use care when disconnecting battery cables. The magnetic switch studs are at battery voltage.

17. Connect the batteries.
18. Prime the fuel system.
Refer to section "Priming the Fuel System - KM63 GEN2 - Two-Filter System"
19. Perform the Rail Pressure Bleed-Off test to verify that there are no leaks.
Refer to section "Rail Pressure Bleed Off Test Using DiagnosticLink® - Two-Filter Fuel System"
20. If there are leaks, find the leak and repair, as necessary.
21. If necessary, install the bumper. Refer to the Original Equipment Manufacturer (OEM) procedures.
22. Close the hood.



13400 Outer Drive, West, Detroit, Michigan 48239-4001
Telephone: 313-592-5000
WWW.DEMANDETROIT.COM

Specifications are subject to change without notice. Detroit Diesel Corporation is registered to ISO 9001:2008. Copyright © Detroit Diesel Corporation. All rights reserved. Detroit™ is a brand of Detroit Diesel Corporation, a Daimler company.

18SP725Rev. 1906 As technical advances continue, specifications will change. Printed in U.S.A.