

1 06 11-19



Service Information Bulletin

SUBJECT	DATE
Symptom Diagnostics - Engine Oil Leaks	June 2019

Additions, Revisions, or Updates

Publication Number / Title	Platform	Section Title	Change
DDC-SVC-MAN-0191	GHG17 DD	Engine Oil Leaks	New procedures added to address diagnostics near the high pressure pump.



13400 Outer Drive, West, Detroit, Michigan 48239-4001
 Telephone: 313-592-5000
www.demanddetroit.com

2 Engine Oil Leaks

NOTE: Detroit™ and the Department of Transportation (DOT) define an external fluid leak as a condition where fluids are pooling or leaking onto the ground.



Figure 1. Example of an Oil Leak - Very Wet with Evidence That Fluid Leaks onto the Ground



d180092

Figure 2. Example of a Seep - Residue Accumulation on the Surface But Remains on that Surface and Does Not Drip onto the Ground

NOTE: Block porosity is an immediate issue and does not happen over time. If there was a block porosity concern present, the porosity issue would be evident when the engine is new.

Check as follows:

1. Shut off the engine, apply the parking brake, chock the wheels, and perform any other applicable safety steps.
2. Was an oil change recently performed on this vehicle?
 - a. Yes; check to make sure that the oil filter and drain plug were properly installed and clean any oil presence spilled from the previous service interval.
 - b. No; Go to step 3.
3. Is oil pooling or leaking onto the ground?
 - a. Yes; Go to step 4.
 - b. No; no leaks are present, release the vehicle.
4. Check vehicle repair history. Are there any recent repairs that could have resulted in oil spills on the engine that would appear as an oil leak?
 - a. Yes; examine the oil spill area of the engine to make sure it is not being perceived as an oil leak.
 - b. No; Go to step 5.

NOTE: Isolating the exact location can be difficult due to fan blast and road grime that can cause the leaking oil to migrate. Oil leaks tend to move in a downward and rearward direction. Look for the highest point of any oil trace.

5. Inspect the entire vehicle for signs of leaks; note any leaks that could be confused for an engine oil leak. Was the source of the leak identified as being caused by the engine?
 - a. Yes; Go to step 6.
 - b. No; identify the non-engine component causing the leak and refer to the component OEM literature for additional information on troubleshooting/repair of the oil leak.
6. Visually inspect the rocker cover gasket, starting at the left front of the engine and continuing down the left side toward the rear of the engine. Is there an external oil leak coming from the rocker cover gasket?

- a. Yes; replace the rocker cover gasket. Refer to section "Removal of the Rocker Cover".
 - b. No; Go to step 7.
7. Visually inspect the Camshaft Position (CMP) sensor for signs of external oil leaks. Is there an external oil leak coming from the CMP sensor?
- a. Yes; replace the O-ring on the CMP sensor. Refer to section "Removal of the Camshaft Position Sensor".
 - b. No; Go to step 8.
8. Visually inspect the camshaft housing seal, starting at the front left and continuing down the left side to the rear. Pay special attention to the rear corner, as leaks are hard to see in this area. Are there any external oil leaks coming from the cam frame housing seal?
- a. Yes; replace the cam housing seal. Refer to section "Removal of the Camshaft Housing Assembly".
 - b. No; Go to step 9.
9. Visually inspect the cylinder head gasket (1), starting at the left front of the engine and continuing down the left side to the rear of the engine. Keep in mind that the oil supply ports are at the front and the rear of the block. Are there any external oil leaks coming from the cylinder head gasket?
- a. Yes; remove the cylinder head and inspect the head gasket oil supply and return seals for damage. Refer to section "Removal of the DD13 Cylinder Head Assembly"
Refer to section "Removal of the DD15 and DD16 Cylinder Head Assembly"
Repair as necessary.
 - b. No; Go to step 10.

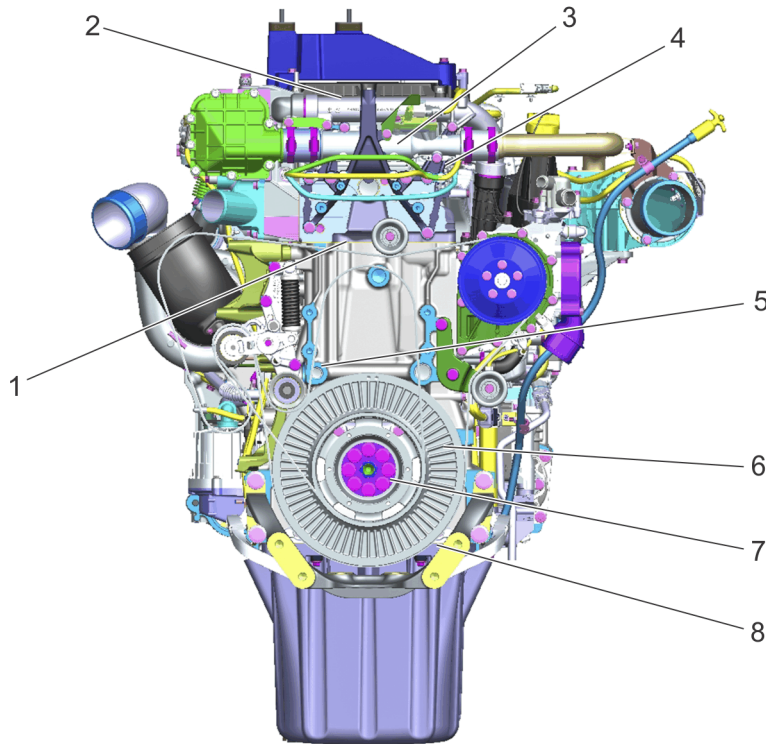

d180096a

- | | |
|---|-------------------------------------|
| 1. Cylinder Head Gasket | 5. Oil Gallery Cup Plugs |
| 2. Rocker Cover Gasket | 6. Front Cover Seal (behind damper) |
| 3. Camshaft Housing Cup Plugs (behind crossover pipe) | 7. Crankshaft Seal (behind damper) |
| 4. Camshaft Housing Seal | 8. Oil Pan Gasket |

Figure 3. Front of Engine (steps 10 - 13)

10. Is oil leaking from the front of the engine?
- a. Yes; Go to step 11.
 - b. No; Go to step 14.
11. Visually inspect the camshaft housing cup plugs (behind the crossover pipe) (3). Are there any external leaks present?

- a. Yes; repair as necessary.
 - b. No; Go to step 12.
12. Visually inspect the oil gallery cup plugs (5) in the cylinder block. Are there any external leaks present?
- a. Yes; repair as necessary.
 - b. No; Go to step 13.
13. Looking behind the damper, inspect for a leaking front cover seal (6) or a leaking crankshaft seal (7). Is either seal leaking?
- a. Yes; repair as necessary.
 - b. No; Go to step 37.

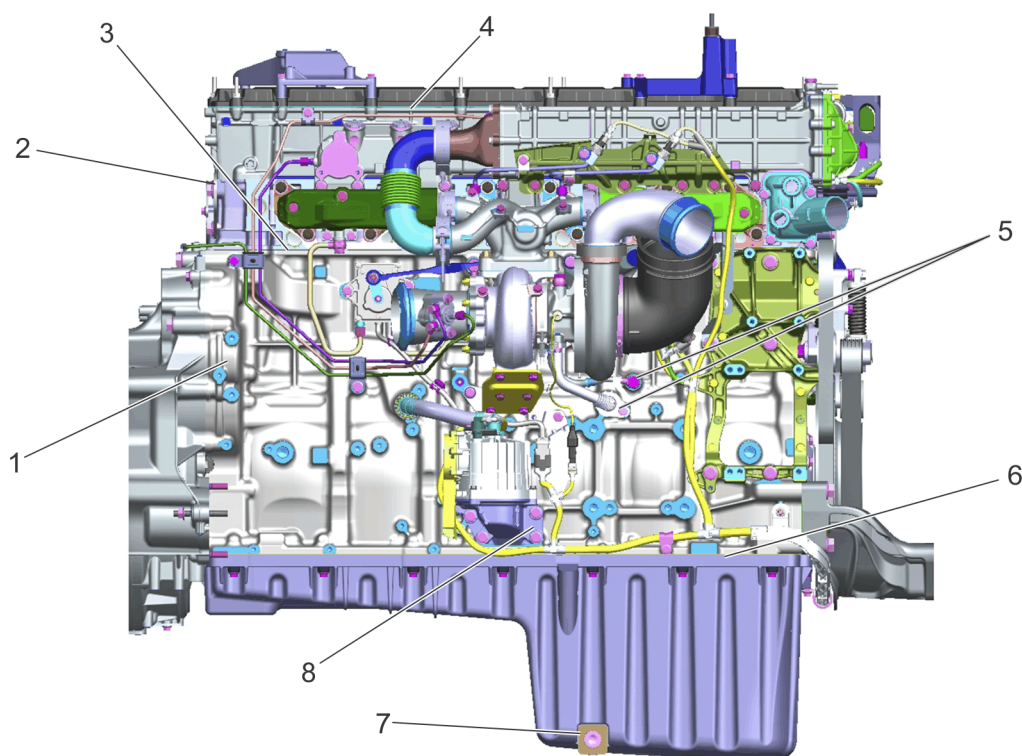

d180094a

- | | |
|---|--------------------------------|
| 1. Cylinder Block Cover Plate (if equipped) | 5. Turbo Oil Supply and Return |
| 2. Camshaft Housing Seal | 6. Oil Pan Gasket |
| 3. Cylinder Head Gasket | 7. Right Oil Drain Plug |
| 4. Rocker Cover Gasket | 8. Crankcase Breather and Tube |

Figure 4. Right Side (steps 14 - 20)

14. Is oil leaking from the right side of the engine?
- a. Yes; Go to step 15.
 - b. No; Go to step 19.
15. Inspect the right side oil drain plug (7). Is there an oil leak present at the oil drain plug?
- a. Yes; repair as necessary.
 - b. No; Go to step 16.
16. Inspect the crankcase breather (8). Check for leaks at the inlet and outlet tubes, fittings, mounting surface to the cylinder block, and the housing-to-cap seal. Are there any external oil leaks present?
- a. Yes; replace the crankcase breather. Verify repair.
 - b. No; Go to step 17.
17. Is oil leaking at the boost pipe?
- a. Yes; inspect for loose clamps, seeping, worn or damaged boost pipe and for a dirty air filter. Then Go to step 18.

- b. No; Go to step 18.
- 18. Inspect the turbocharger assembly and related parts.
 Refer to section "Inspection of the DD13 and DD15 Turbocharger"
 Refer to section "Inspection of the DD16 Turbocharger"
 Check for leaks at the inlet and outlet pipes, oil supply and drain lines, speed sensor, speed sensor O-ring, sealing surface between the turbocharger assembly and the engine block. Are there any external oil leaks present?
 - a. Yes; repair as necessary.
 - b. No; Go to step 37.

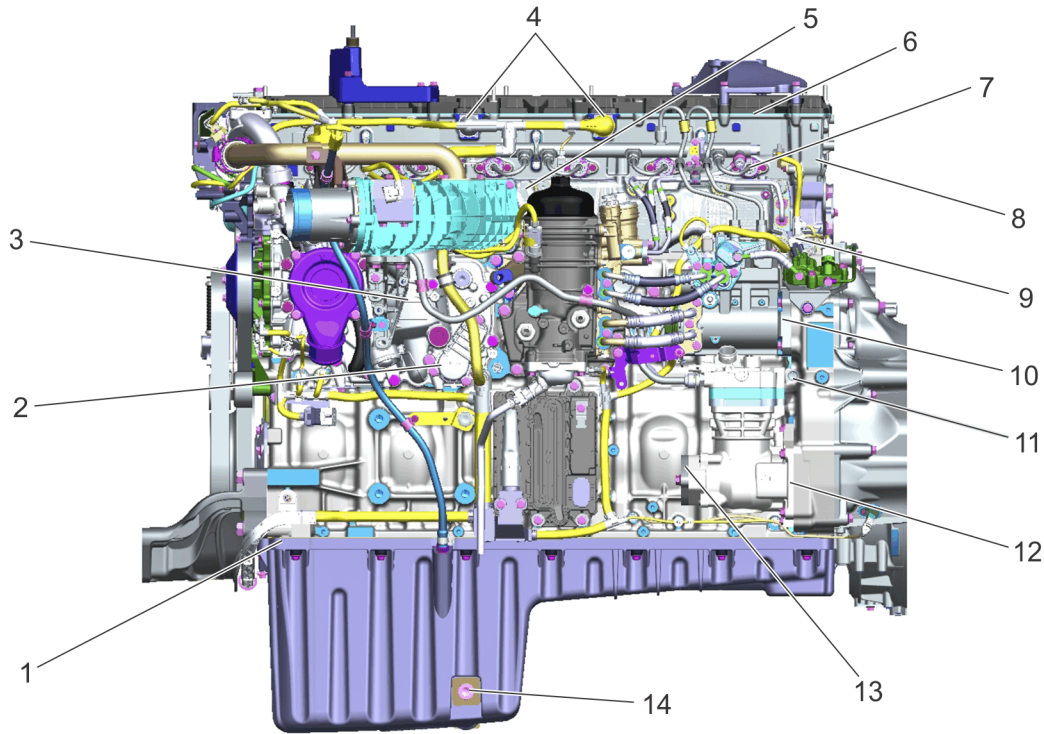

d180093a

- | | |
|--------------------------------------|--|
| 1. Oil Pan Gasket | 8. Cam Position Sensor O-ring |
| 2. Oil Thermostat Cover Plate Seal | 9. Cylinder Head Gasket |
| 3. Oil Coolant Module (see 13TS-10) | 10. High Pressure Pump Mounting Seal |
| 4. Injector Harness Grommets | 11. Oil Gallery Cup Plug between High Pressure Pump and Air Compressor |
| 5. Camshaft Housing Seal | 12. Air Compressor Mounting Seal |
| 6. Rocker Cover Gasket | 13. Power Steering Pump Mounting Gasket |
| 7. High Pressure Transfer Line Seals | 14. Left Oil Pan Plug |

Figure 5. Left Side (steps 21 - 33)

- 19. Is oil leaking from the left side of the engine?
 - a. Yes; Go to step 20.
 - b. No; Go to step 32.
- 20. Inspect the left side oil pan plug (14). Is there an oil leak present at the oil pan plug?
 - a. Yes; repair as necessary.
 - b. No; Go to step 21.
- 21. Visually inspect the oil pressure and oil temperature sensors for signs of external oil leaks. Leaks can be present at the sensors or O-rings. Is there an external oil leak coming from either sensor?
 - a. Yes; repair as necessary.
 - b. No; Go to step 22.
- 22. Visually inspect the injector harness grommets (4). Are there any external leaks present?

- a. Yes; replace the injector harness grommets.
 - b. No; Go to step 23.
23. Visually inspect the high pressure fuel injector line seals for each cylinder. Are any of the high pressure fuel injector line seals leaking?

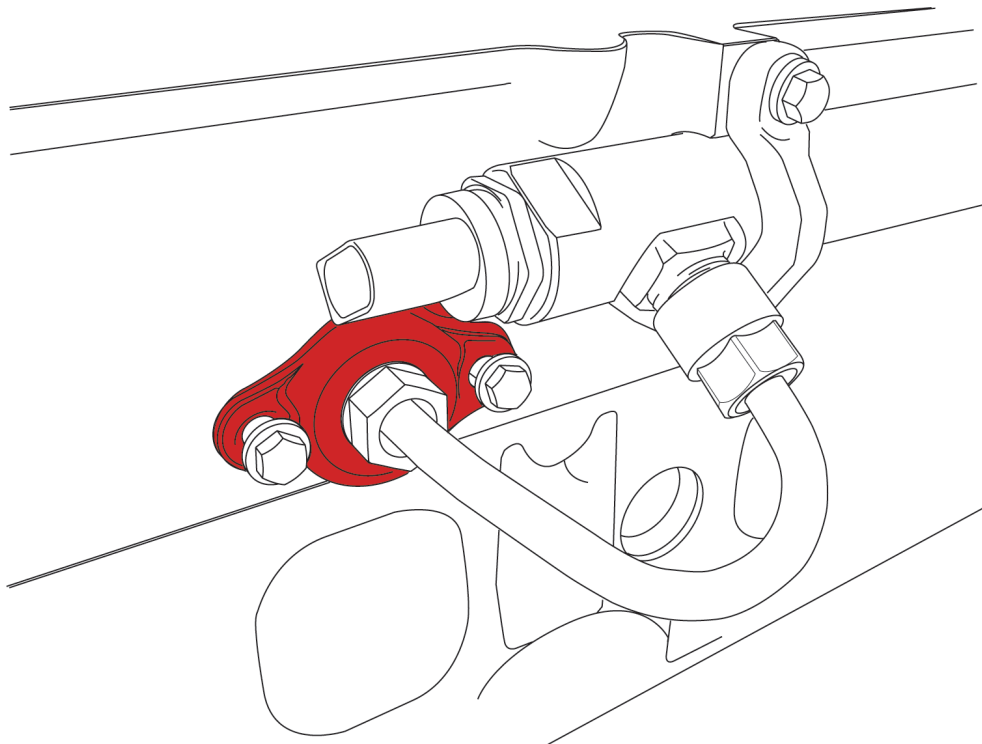

d470370

- a. Yes; replace the high pressure fuel line injector line seal(s) that are leaking.
- b. No; Go to step 24.

NOTE: When inspecting the oil coolant module, consider that oil might be spilled around the filler neck and oil filter cap area during service intervals. These spills can sometimes lead to misdiagnosis.

24. Inspect the oil coolant module. Check for leaks at the oil fill neck, oil filter cap, oil thermostat cover, plugs, and around the sealing surface between the oil coolant module and the engine block. Are there any external oil leaks present?
- a. Yes; repair as necessary.
 - b. No; Go to step 25.
25. Inspect the oil dipstick tube. Are there any external oil leaks present?
- a. Yes; repair as necessary.
 - b. No; Go to step 26.
26. Inspect the cylinder block oil gallery cup plug, located two inches under the high pressure fuel pump (11). Is there an external oil leak at the cup plug?
- a. Yes; replace the cup plug. Refer to section "Replacement of the Oil Gallery Cup below the High Pressure Fuel Pump".
 - b. No; Go to step 27.



d010423

Figure 6. Example of Assembly Grease Residue around High Pressure Fuel Pump

NOTE: Assembly grease will start to drip after continued engine use and is NOT a sign of an oil leak.

27. Check for leaks at the High Pressure Fuel Pump (HPFP) (10). Are there any external oil leaks at the HPFP weep hole or where the HPFP mates to the engine block?
 - a. Yes; Go to step 28.
 - b. No; Go to step 30.
28. Use the Oil Developer Method around the HPFP. Refer to section "Engine Oil Leaks - Oil Developer Method". Did the Oil Developer Method show fresh oil leaks around the HPFP?
 - a. Yes; Go to step 29.
 - b. No; Go to step 30.
29. Remove the HPFP and inspect its camshaft seal. Is damage present?
 - a. Yes; install a new HPFP and mounting O-ring.
 - b. No; install a new mounting O-ring and reinstall the HPFP.
30. Inspect the air compressor assembly; check for oil leaks at the compressor's cup plug. Are there any external oil leaks present?
 - a. Yes; replace the air compressor.
 - b. No; Go to step 31.
31. Inspect the air compressor flange where it mates to the engine block. Is there an external oil leak present?
 - a. Yes; remove the air compressor, clean the area, replace the O-ring, and reinstall the air compressor.
 - b. No; Go to step 32.
32. Inspect the seal between the rear of the air compressor and the power steering pump. Is there an external oil leak present?
 - a. Yes; remove the power steering pump, replace the seal, and reinstall the power steering pump.
 - b. No; Go to step 38.

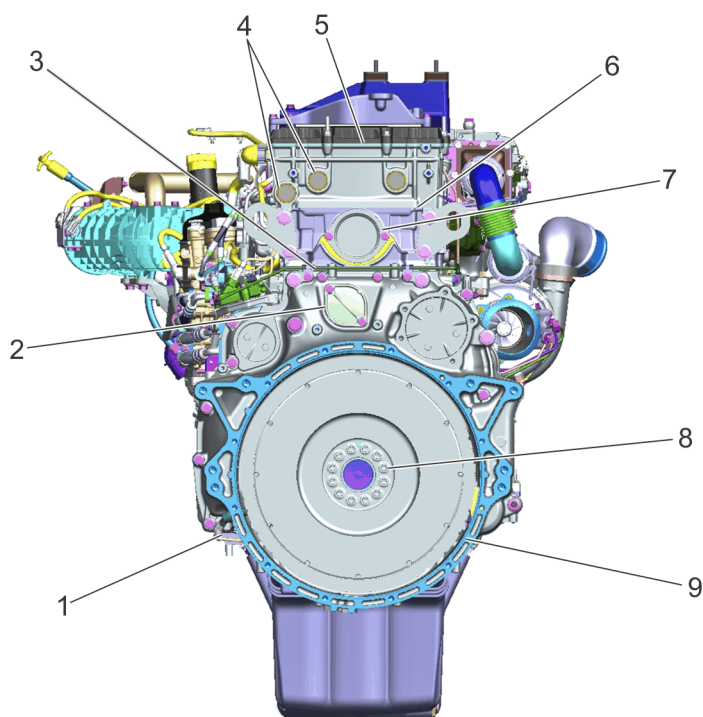

d180095a

- | | |
|-------------------------------|--------------------------------------|
| 1. Oil Pan Gasket | 6. Camshaft Housing Seal |
| 2. Access Plate for #3 Idler | 7. Access Plate for #5 Idler |
| 3. Cylinder Head Gasket | 8. Rear Crank Seal (behind flywheel) |
| 4. Camshaft Housing Cup Plugs | 9. Flywheel Housing Gasket |
| 5. Rocker Cover Gasket | |

Figure 7. Back of Engine (steps 34 to 38)

33. Visually inspect the camshaft housing cup plugs (4). Is there an external oil leak present?
 - a. Yes; repair as necessary.
 - b. No; Go to step 34.
34. Visually inspect the camshaft housing seal (6). Is there an external oil leak present?
 - a. Yes; replace the cam housing seal. Refer to section "Removal of the Camshaft Housing Assembly".
 - b. No; Go to step 35.
35. Visually inspect the access plate for #5 idler (7). Is there an external oil leak present?
 - a. Yes; repair as necessary.
 - b. No; Go to step 36.
36. Visually inspect the access plate for #3 idler (2). Is there an external oil leak present?
 - a. Yes; repair as necessary.
 - b. No; Go to step 37.
37. Visually inspect the flywheel housing for leaks (9). Is there a leak on the lower 6 inches of the flywheel housing?
 - a. Yes; Go to step 38.
 - b. No; the oil leak is generated by either the flywheel housing gasket or the rear crankshaft seal. Inspect and repair as necessary.

NOTE: For oil pan gasket warranty submissions, you may choose to use the image below to mark the location of the leak on the oil pan gasket. When replacing an oil pan gasket, Refer to section "Installation of the Oil Pan".

38. Inspect the oil pan starting at the front of the engine working towards the rear of the engine. Is there an external oil leak present?

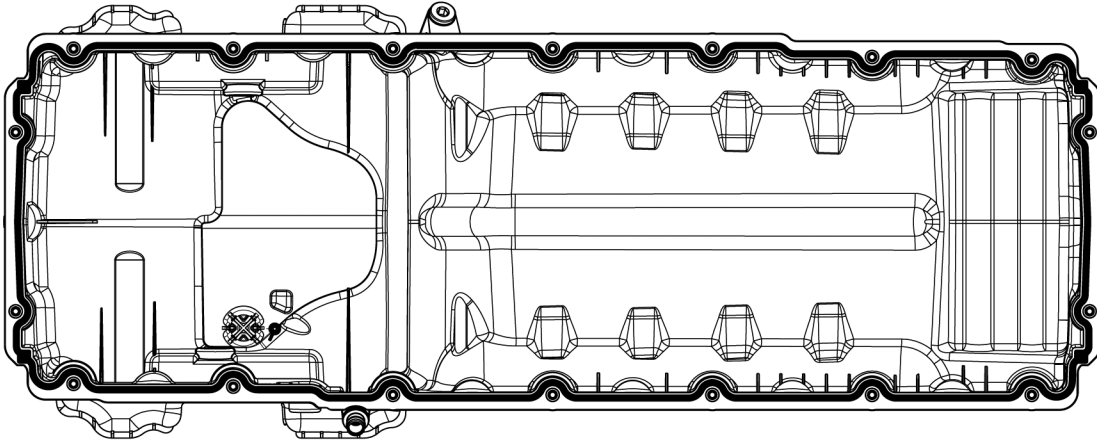

d010243

- a. Yes; repair as necessary.
- b. No; Refer to section "Engine Oil Leaks - Oil Developer Method".