

Sport Plus Mode

Revision: **This bulletin replaces bulletin Group 9, #9/14, dated February 2, 2015.**

- > Applicable model year was changed to "As of 2014, up to 2016".
- > Information under "Notes" was revised.
- > Work procedures were revised.

Model Year: **As of 2014 up to 2016**

Concern: **Retrofitting**

Restrictions:

- **ONLY** for vehicles **WITHOUT** compass/Sport Chrono clock (I-no. QR0) or **WITH** analog clock (I-no. QR3)



Figure 1

Notes: Activating the option "Sport Plus mode" using the Sport Plus button in the center console will enable the following functions, depending on vehicle equipment:

- Sporty tuning of Porsche Stability Management (PSM), Porsche Active Suspension Management (PASM), Porsche Traction Management (PTM) and shift program
- Racing start function Launch Control¹ (Only together with Porsche Doppelkupplung (PDK))

¹ Contrary to the description in the Owner's Manual, the engine speed of engines is limited to 3,500 rpm for the racing start function Launch Control. Please inform the customer about the different engine speed.

When Sport Plus mode is activated, the Porsche control systems are intentionally shifted towards greater agility and driving dynamics (for more information ⇒ Owner's Manual).

The Sport and Sport Plus modes are displayed in the instrument cluster. When driving off with Launch Control, the message "Launch Control activated" is displayed on the on-board computer.

ONLY for vehicles with PCM 3.1:

Data relating to laps/distances driven can be recorded and evaluated when the stopwatch (digital display in the instrument cluster) and Porsche Communication Management (PCM) are combined. To do this, you must request the **PCM Sport Chrono MMI enabling code** and enable this option.

Important:

ONLY for vehicles with analog clock (QR3):

When coding is complete, **B** will be displayed instead of **A** in the main menu Vehicle > Settings > Date/time on the multi-function display in the instrument cluster.



Multi-function display

- A - Clock lighting
- B - Chrono time

The clock lighting works when the Chrono time option is confirmed (tick appears).



Information

Please inform your customers about the change in the multi-function display.

Parts Info: **95B.044.900.70** ⇒ Sport Plus mode

Also order the following in accordance with vehicle equipment:

95B.907.041.P.DML ⇒ Strip for switches, suspension/damping: Standard (1BA)/(QR4/QR5)

95B.907.041.Q DML ⇒ Strip for switches, suspension/damping: Standard-2 (1BH = PASM)/(QR4/QR5)

95B.907.041.R DML ⇒ Strip for switches, air suspension with levelling system and height adjustment: (1BH = PASM)/(QR4/QR5)

Enabling Code: Sport Chrono and PCM Sport Chrono MMI, if necessary:

These components require a VIN-specific enabling code and will not function without it. To get the enabling code, order the applicable kit via your normal parts channels (POLARIS). You must then submit a Parts Technical Assistance Request (PTAR) in the PTEC system with the correct VIN, Part Number and PCNA order number to PCNA Parts Support. The PTAR will be returned to you in 1+ working days, advising you that the code is now displayed in the PIWIS System. Consult Parts Bulletin GR13D90 for additional ordering details.

Tools: **9900 - PIWIS Tester 3**

Work Procedure: 1 Preparatory work

- 1.1 Connect battery charger (⇒ *Workshop Manual '2X00IN Battery trickle charging*).
- 1.2 Remove selector knob (⇒ *Workshop Manual '370419 Removing and installing selector knob*).
- 1.3 Remove upper part of center console cover (⇒ *Workshop Manual '681919 Removing and installing upper part of centre console cover*).
- 1.4 Remove switch console (⇒ *Workshop Manual '962719 Removing and installing switch console*).

2 Replace standard strip for switches (left).

- 2.1 Remove strip for switches.

2.1.1 Unplug electric plug connection
(⇒ *Figure 3*).

- 1 - Electric plug connection
- 2 - Screw
- 3 - Strip for switches (left)

2.1.2 Unscrew screws (⇒ *Figure 3-2-*).

2.1.3 Remove strip for switches at the left
(⇒ *Figure 3-3-*).

2.2 Install new strip for switches in reverse order.

3 Concluding work.

3.1 Install switch console (⇒ *Workshop Manual '962719 Removing and installing switch console*).

3.2 Install upper part of center console cover (⇒ *Workshop Manual '681919 Removing and installing upper part of centre console cover*).

3.3 Install selector knob (⇒ *Workshop Manual '370419 Removing and installing selector knob*).

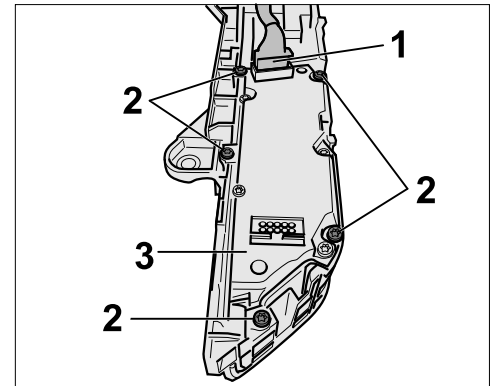

Figure 3

NOTICE

Voltage drop

- Risk of irreparable damage to control unit
 - Risk of damage to control unit
 - Fault entries in the control unit
 - Coding in the control unit is aborted
 - Malfunctions in control unit, even during programming
- ⇒ Prior to disconnecting the control unit, switch off the ignition and remove the ignition key.
- ⇒ Ensure that the power supply is not interrupted during programming.
- ⇒ Connect battery charger/power supply suitable for AGM Type batteries, recommended current rating of 90A fixed voltage 13.5V to 14.5V.



Information

The **9900 - PIWIS Tester III** instructions take precedence since the description may be different with later Tester releases.

The procedure described here has been structured in general terms; different text or additions may appear on the **9900 - PIWIS Tester III**.



Information

The following requirements must be met for coding Sport Plus mode:

- Software version 14.100 or higher
- Sport Chrono enabling code available

4 Coding Sport Plus mode

4.1 **9900 - PIWIS Tester 3** must be connected before switching on the ignition.

4.2 Select the required vehicle type. PIWIS Tester Diagnostics starts.

4.3 Maintenance of vehicle data

4.3.1 Select Additional menu by pressing **•F7** . Press **•F11** to confirm the question "Create vehicle analysis log (VAL)?".

4.3.2 Select the "Maintenance of vehicle data" function. Press **•F12** until "PR numbers" appears in the Value group column.

4.3.3 Select "Compass" in the Family column. Touch the empty cell behind "Compass" - a dropdown menu appears.



Information

If QR4 or QR5 is selected, a window opens prompting you to enter the Sport Chrono enabling code.

ONLY for vehicles with audio system CDR Plus:

Select "QR4 - Sport Chrono Package". Enter the enabling code and press OK to confirm. Press **•F12** to continue.

ONLY for vehicles with PCM3.1:

Select "QR5 - Sports Chrono Package Plus", enter the enabling code and press **•OK** to confirm.

Continue with **•F12** .

4.3.4 A table containing the values to be changed appears.

Save the values by pressing **•F8** .

Wait until "Generation of vehicle data is complete....." appears.

4.3.5 Press **•F12** to switch to Report management.

Open the log by pressing **•F10** and check that vehicle equipment "Sport Chrono Package Plus - QR5" or "Sport Chrono Package - QR4" is displayed.

Close the log.

4.4 Adapt coding.

4.4.1 Switch to the "Overview" menu. Press **•F11** to return to the list of control units.

- 4.4.2 Select all control units by pressing •Ctrl A" . Press •F12" to continue.
- 4.4.3 Switch to the "Codings/adaptations" menu. Press •F12" to continue.
- 4.4.4 Select "Automatic coding" mode. Press •F12" to continue.
- 4.4.5 Wait until "Coding has been completed successfully" appears. Press •F12" to continue.
- 4.4.6 Switch to the "Overview" menu.
- 4.5 **ONLY** for vehicles with PCM3.1:
Enable PCM Sport Chrono MMI.
 - 4.5.1 Select "PCM" control unit. Press •F12" to continue.
 - 4.5.2 Switch to the "Maintenance/repairs" menu.
 - 4.5.3 Select the "Function enable" option. Press •F12" to continue.
 - 4.5.4 Enable the "Sport Chrono" function, enter the enabling code and confirm by touching the "Status" cell.
 - 4.5.5 Press •F8" to execute. Wait until "Enable was successful" appears. Press •F12" to continue.
- 4.6 Read out the fault memory of all systems, work through any existing faults, and erase the fault memory (⇒ *Workshop Manual '033500 Fault memory for on-board diagnosis*).
- 4.7 Carry out a function test.
- 4.8 Disconnect battery charger. (⇒ *Workshop Manual '2X00IN Battery trickle charging*).
- 4.9 Switch off ignition and disconnect **9900 - PIWIS Tester 3**.

96 27 31 40: –Activating Sport Plus mode–

Labor time: **85 TU**

Important Notice: Technical Bulletins issued by Porsche Cars North America, Inc. are intended only for use by professional automotive technicians who have attended Porsche service training courses. They are written to inform those technicians of conditions that may occur on some Porsche vehicles, or to provide information that could assist in the proper servicing of a vehicle. Porsche special tools may be necessary in order to perform certain operations identified in these bulletins. Use of tools and procedures other than those Porsche recommends in these bulletins may be detrimental to the safe operation of your vehicle, and may endanger the people working on it. Properly trained Porsche technicians have the equipment, tools, safety instructions, and know-how to do the job properly and safely. Part numbers listed in these bulletins are for reference only. The work procedures updated electronically in the Porsche PIWIS diagnostic and testing device take precedence and, in the event of a discrepancy, the work procedures in the PIWIS Tester are the ones that must be followed.

© 2019 Porsche Cars North America, Inc.