

J coach New Windshield Fence

Description:

Motor Coach Industries ("MCI") is instructing customers operating J Coach 2018/19 with windshield leaks to follow this procedure to prevent water leaks.

Replace non-MCI supplied windshield if present with MCI windshield before starting this procedure.



Read this entire procedure before beginning work.

Use Safe Shop Practices At All Times.

To avoid personal injury:

- a. Proper Personal Protective Equipment (PPE) must be worn. Safety glasses and protective gloves are required for working with DEF Fluid.***
- b. Turn the main battery disconnect switch to the OFF position.***
- c. Ensure that both the front and the rear wheels are chocked.***
- d. Position the ENGINE RUN and ENGINE START switches on the engine compartment remote control box to the OFF position.***
- e. Allow enough time for components to cool down prior to working in the engine compartment.***

1.0 Special Tools

Fence Tool (MCI P/N: P101)

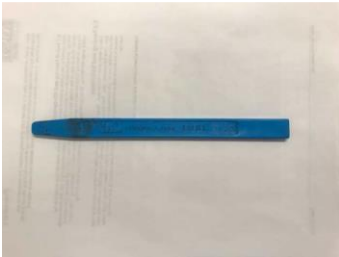

Fence Tool

2.0 Windshield Inspection

To perform this procedure there must be an MCI approved windshield installed. Look for an MCI logos on the windshield at the below-shown location. If the logos are not present the windshield must be replaced by an MCI approved windshield before continuing.

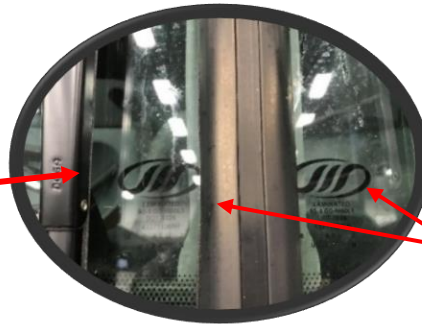

MCI Logos

3.0 Replace windshield fence

3.1 Material requirement

Item	Part Number	QTY	U/M	Description
1	T03-3046	1	EA	Fence- Windshield
2	T03-3011	1	EA	Adhesive- Urethane, 3M 08609
3	23-02-0122	1	EA	Primer- Activator Teroson PU 8519p

Additionally, four .188" dia Al rivets (MCI P/N: 19-13-295) are required if the coach is equipped with 360 Camera.

3.2 Remove the existing fence

NOTICE

CAUTION

If the coach is equipped with wingman fusion camera, remove the two screws on the camera cover. Save the screws and cover for later use.



Disconnect the camera wiring and leave the camera attached to the windshield.

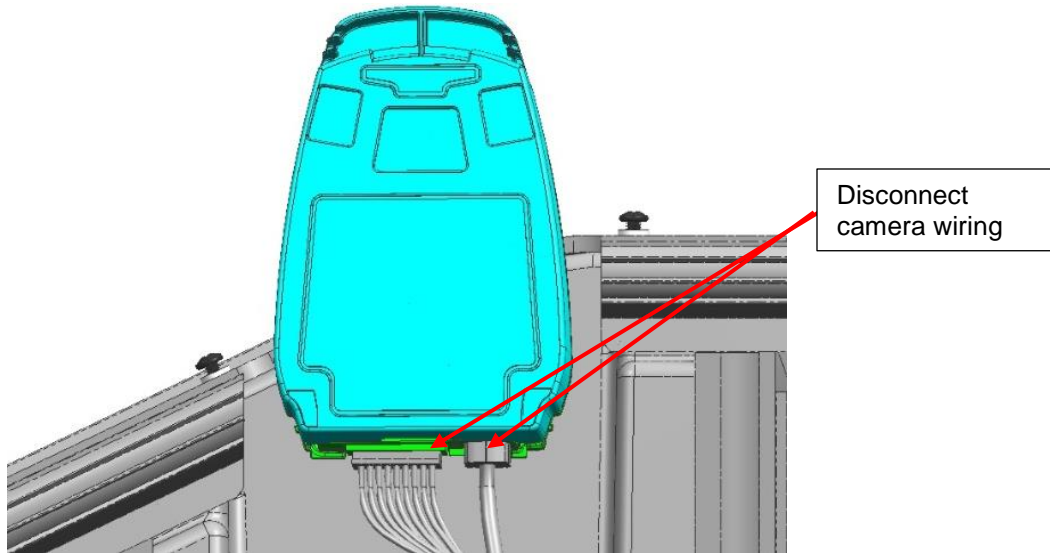

Remove and save the cap on the wiper arm of driver side windshield. Remove and save the retaining nut. Repeat this on the other wiper arm. Disconnect the washer hose on the wiper. Remove and save the wiper.

Repeat the above steps for the curbside windshield wiper.



Remove and save the retaining nut



Disconnect the washer hose

Remove and save the fascia from the fence.



Remove and save the fascia

Remove and save the lacing from the fence.

Use the fence tool to separate the fence from the glass and spray lubricant, like soap waster, between fence and windshield.

Remove and save the windshield on the driver side and curbside.



Remove and save the windshield

NOTICE

CAUTION

If the coach is equipped with wingman fusion camera, leave the camera attached to the windshield.



Remove fence from the front cap and discard.

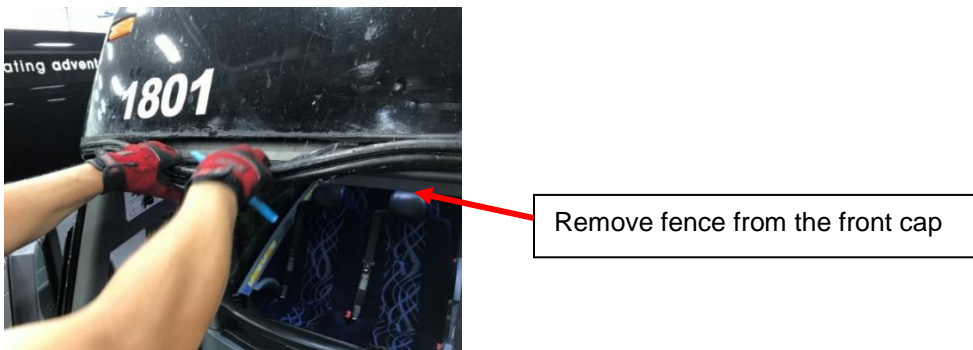

Clean all adhesive and sealant on the front cap using lacquer thinner.



NOTICE

CAUTION

If the coach is equipped with 360 camera, remove and save the four screws securing the top bracket of the camera.



Remove and save the four screws

Remove the four rivets securing the bottom bracket of the camera.

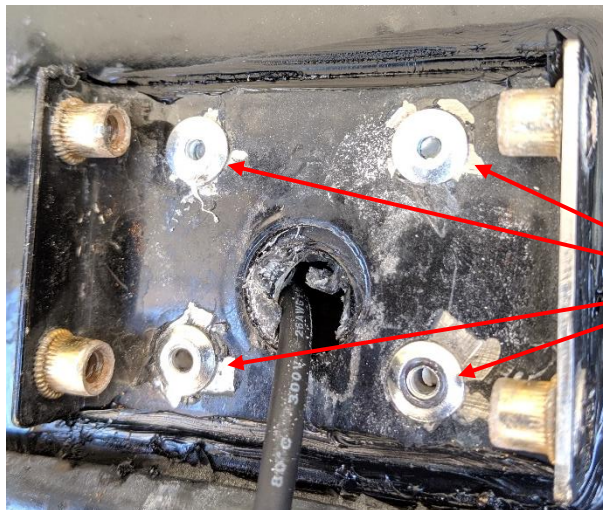

Remove the four rivets

Drill two .187" holes using 3/16" drill bit at .5" above the existing bottom holes as shown below.

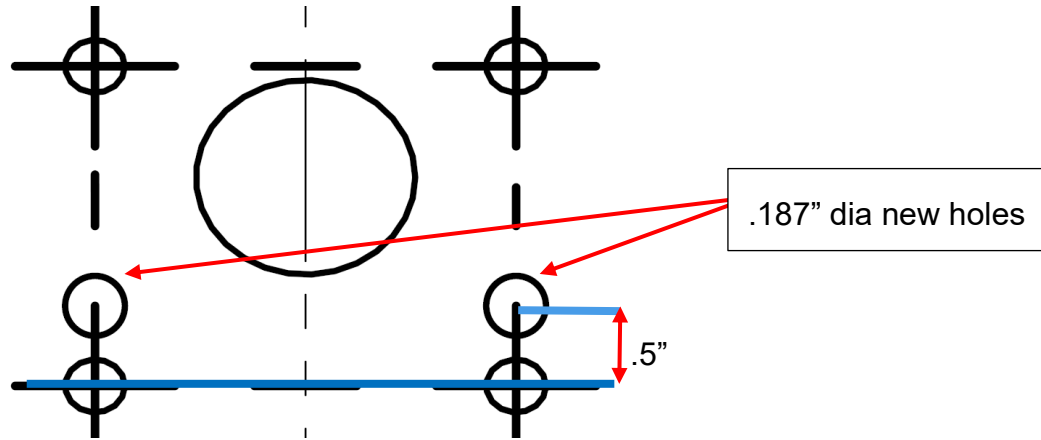

Apply urethane to fill the old four holes on the coach and install the bottom bracket to the newly drilled holes using .188 dia Aluminum rivets, MCI P/N: 19-13-295.

With the bracket as template drill the other two .187" dia holes on the front cap. Secure the bracket using two .188 dia Aluminum rivets, MCI P/N: 19-13-295.

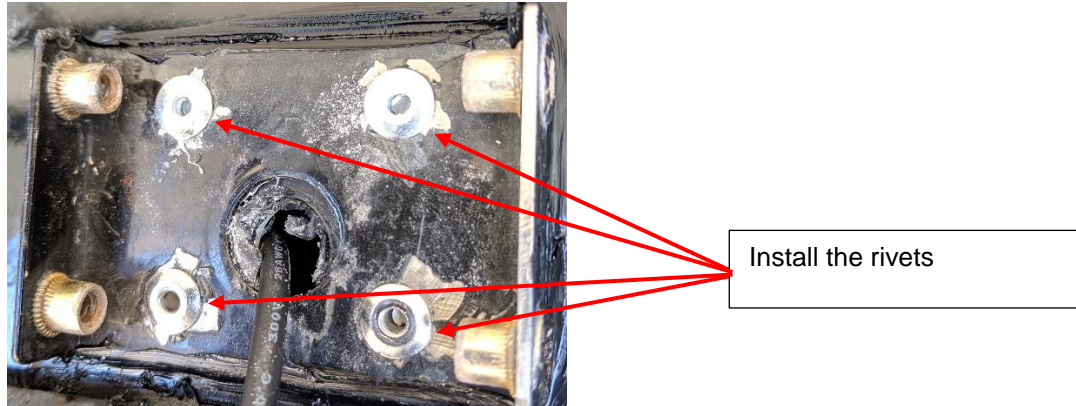

Install the top bracket using existing hardware.



3.3 Install new fence

Apply primer, MCI P/N: 23-02-0122, along the outside groove of the new fence, MCI P/N: T03-3046, and allow 5 minutes flash off time. Apply a bead of urethane adhesive, MCI P/N: T03-3011, all over the outside groove of the fence and install the fence, MCI P/N: T03-3046.



Updated Fence T03-3046

Apply a lubricant, similar to MCI P/N: 21-7112-15, along the inside surface of the fence and install driver side windshield. Use fence tool to help slide window into the fence groove.



Use fence tool to slide window into fence groove.

Repeat the process for the curbside windshield.

Place masking tape along the edge of the windshield fence on the front cap.

Apply adhesive T03-3011 between fence and front cap along the top edge of the fence. Apply enough that it fills the gap and allow the excess adhesive to run out on the tape.



Apply Urethane between fence and front cap.



Excess adhesive coming out of fence

Place the bottom of fascia in fence and use fence tool to run across the bottom to install fascia as shown below.



Installing fascia

Cut the top right and left top corners the lacing at a 45-degree angle.

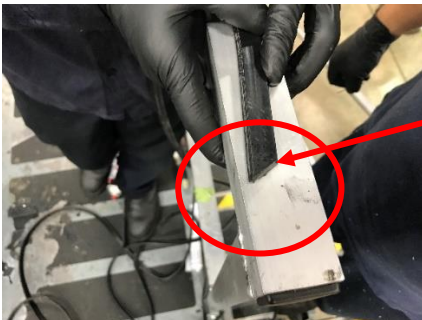

Corners cut at a 45-degree

Install the lacing.

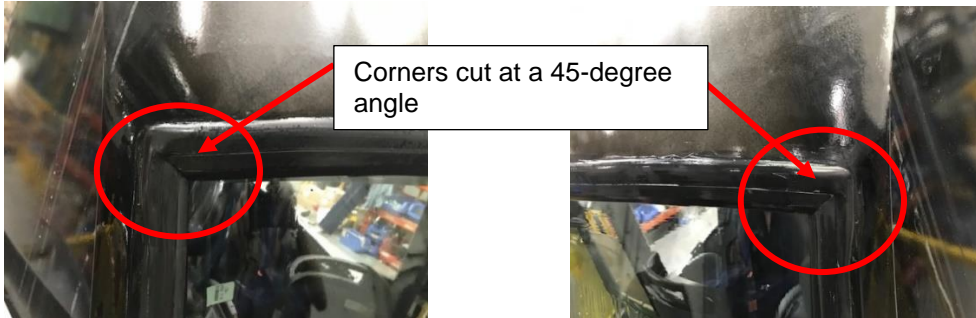

Apply a bead of the adhesive T03-3011 across the top of the fence and then smoothen it with a cloth.

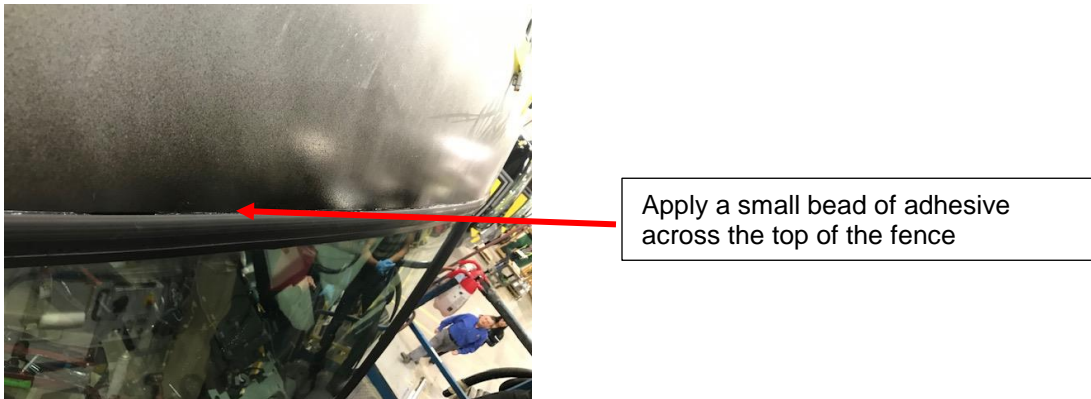

Let the adhesive dry for 2 hours.

Install the wipers using retaining nuts in such a way that the wiper blades are parallel to the middle section of the fence and are 4 inches away from the edge.

Torque the nuts to 26-33 LB-FT.

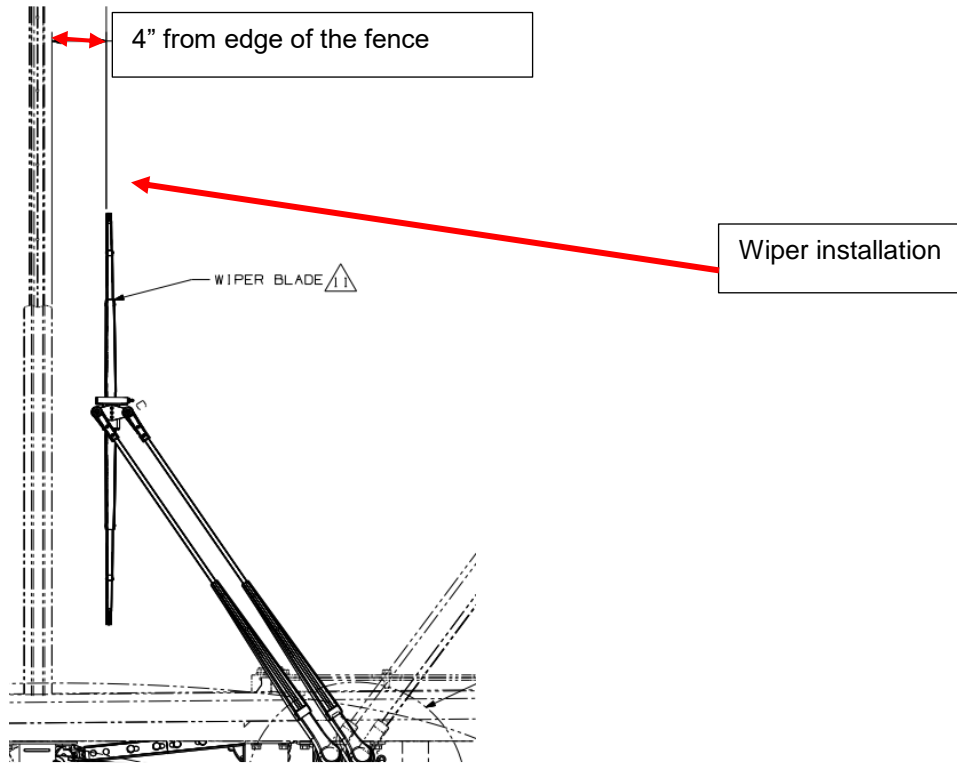

Install wiper arm cap.



Install the washer hose and clean the coach.



Install washer hose

NOTICE

CAUTIONS

If the coach is equipped with wingman fusion camera, connect the wiring to the camera attached to the windshield.

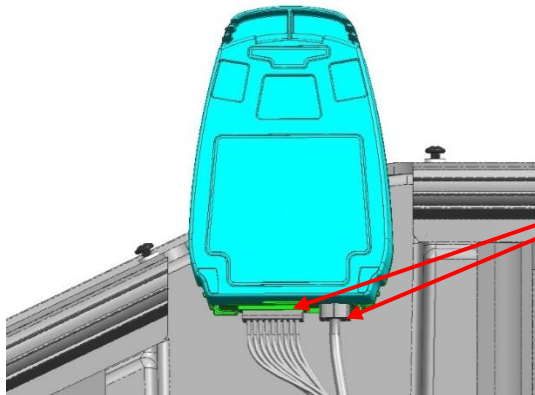

Connect camera wiring

Install the camera cover using existing hardware.



Camera cover

Existing screws

End of the procedure