

Subject: Front Steering Hoses Recall

Bulletin Type: Service Campaign Recall

Bulletin No: TS45-SR-1901

PQR No:

Rev No:

Ref. No: 700003681

Vehicle Model: TS45

Flat Rate Time / Code: 120 min

Date of issue: 09.09.2019

Modify Before:

What to do with off coming parts:

- Scrap
- Return
- Use with additional parts
- On consignment
- No off coming parts

What to do with outstanding parts of previous revision:

- Scrap
- Return
- Use with additional parts
- On consignment
- No outstanding parts

Description of the modification:

This document describes the recommended steps for the replacement of the steering hoses on the front axle

Bulletin Responsible: Ahmet Ozan Özcan

Published & Approved By: Sibel Perçin

## SAFETY INSTRUCTIONS

### 1. Mechanical Requested



**Dress Code**

#### **WARNING:**

- Dress properly to avoid personal injury and damage to the vehicle

- ✓ Always wear protective clothing
- ✓ Do not wear any worn or loose-fitting clothing
- ✓ Remove jewelry before starting to work
- ✓ In case of long hair, use hairnet
- ✓ The illustration on the left shows some of the correct and incorrect clothing
- ✓ Sharp edged items should be avoided in order not to scratch vehicle (i.e. belts, watches, necklace)

### 2. Protect Seats when Mechanic Starts Working




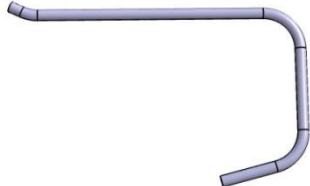
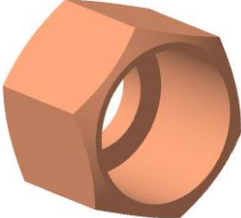


- ✓ Seats, trimming, upholstery stuff and carpeting should be protected with appropriate coverings.

### 3. Welding on the Chassis

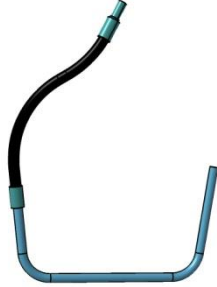
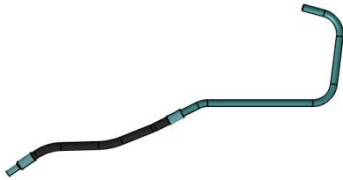

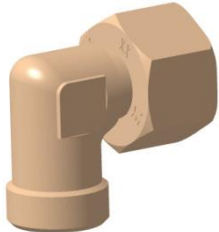


- a. Always disconnect the batteries (starting with the negative lead).
- b. Disconnect the connectors of electrical and electronic equipment (electronic control units, sensors and actuators) if they are less than 2 meters away from the chassis part to be welded or the earth terminal of the welding equipment.
- c. The earth terminal should never be attached to vehicle components such as engine, axles and springs. Arcing on these parts is not permitted, because of the risk of damage to bearings, springs, etc.
- d. The earth terminal must make good contact and be placed as close as possible to the part to be welded.
- e. Plastic pipes, rubber parts and parabolic springs should be well protected against welding spatter and temperatures higher than 70°.
- f. The contact switch must not be in the accessory or contact position. The contact key should be removed.
- g. . Ensure that a good earth connection Reconnect in reversed order of disconnecting is made between chassis, engine and cab.

## INCLUDED PARTS LIST

No	Part No	Part Name	Picture	Qty	Unit of Measure
1	9630-35Y	STEERING SYSTEM HOSE FLAT 450		1	Piece
2	9630-36Y	STEERING SYSTEM HOSE FLAT 439		1	Piece
3	YP9641-28-244Y	FUEL PIPE, Ø15x1, 304L		1	Piece
4	YP9641-28-247Y	FUEL PIPE, Ø15x1, 304L		1	Piece
5	61102-90020-11	CONNECTOR NUT		4	Piece

6	61102-90000-24	FERRULE (GRIP RING)		4	Pieces
7	MH020805Y (Rev:AA)	CLIP		2	Pieces
8	9632-16Y	FLAT, MALE M18x1,5 SHE Ø15 ,GE15ZLMEDCF		2	Pieces
9	MF140005Y	BOLT,HEX,FLANGE (M6X0.9X16 4T) K:5.8		3	Piece
10	MF434103Y	NUT,HEX,FLANGE(M6)		3	Piece
11	9326-7238Y	BRACKET , LIMITER 3X22X30 mm		1	Piece

## EXCLUDED PARTS LIST

No	Part No	Part Name	Picture	Qty	Unit of Measure
1	9630-07Y	STEERING SYSTEM HOSE		1	Piece
2	9630-08Y	STEERING SYSTEM HOSE		1	Piece
3	TM153298Y	CONNECTOR		2	Pieces
4	61102-90000-21	ELBOW CONNECTOR		1	Piece
5	MH020805Y (Rev:00)	CLIP		2	Pieces
6	MF660067Y	WASHER, (1X18X26)		2	Piece

## TECHNICAL INSTRUCTIONS

1. Make the following preparations;

- Take the vehicle to the pit and or lift area.
- Stop the engine. (Lift the vehicle with 6 lifts on all three axles.)
- Make sure that the front wheels are in the straight-ahead position.

**WARNING** Before disassembling the hydraulic hoses make sure that the steering system oil is cold. Open steering system hydraulic connections slowly to prevent injury due to high pressure.

2. Application area; (See Figure-1 and Figure-2)

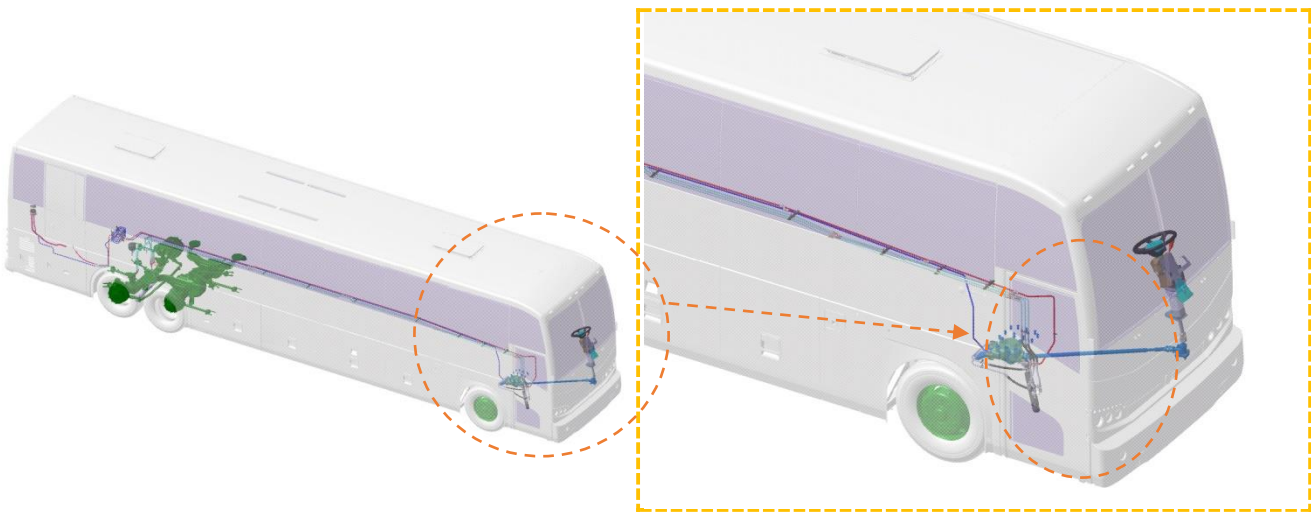


Figure-1

Figure-2

4. The 9630-07Y and 9630-08Y numbered steering hoses (shown with orange color) will be replaced (See Figure-3 and 4)

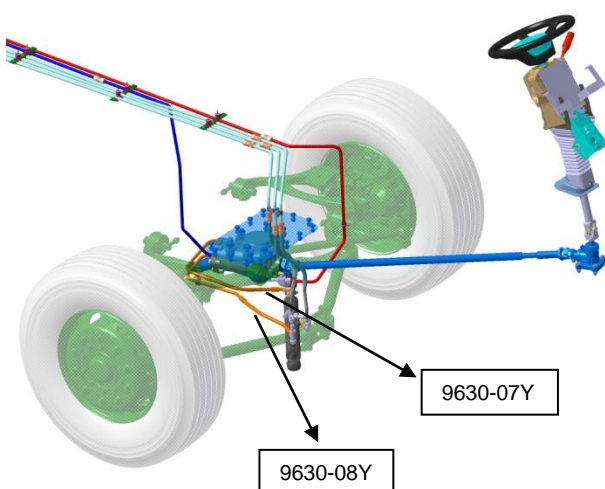


Figure-3

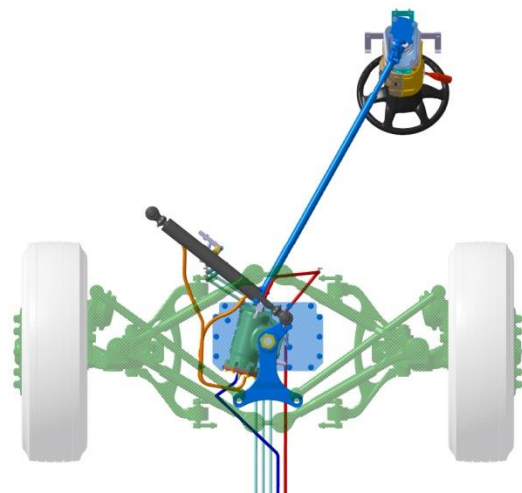


Figure-4



- To dismount the steering hoses, remove the connectors and clips which is shown in picture below (**See Figure-5**)

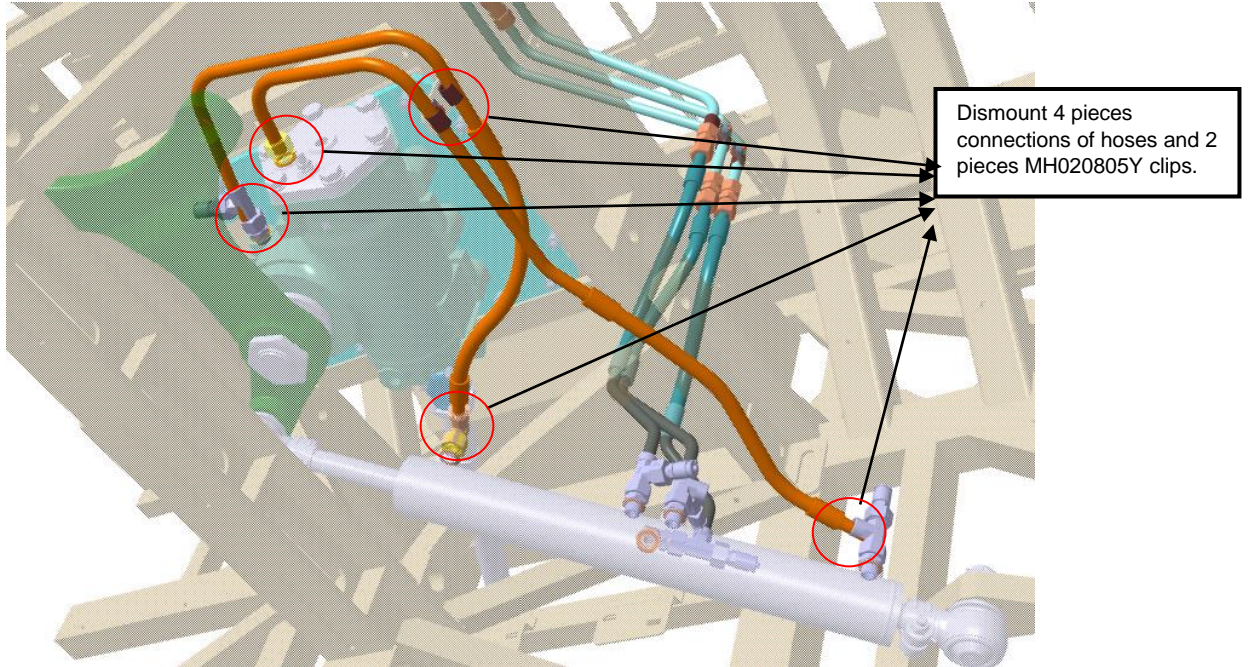


Figure-5

- Mount the 9630-35Y numbered hose and YP9641-28-244Y numbered pipe with using 61102-90000-24Y and 61102-90020-11Y as showed in the **Figure-6**. (Look at the Note-1 in page 11 for the tightening procedure.)

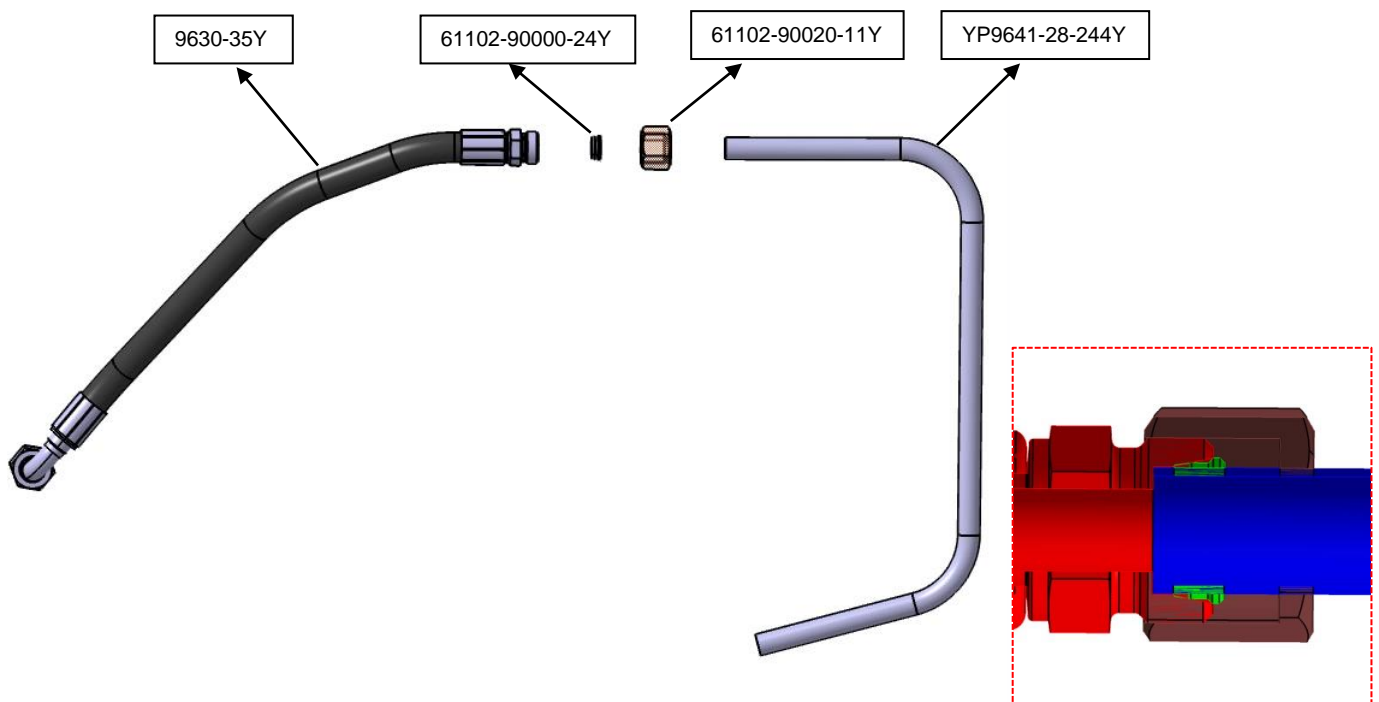


Figure-6

7. Mount the 9630-36Y numbered hose and 9641-28\_247Y numbered pipe with using 61102-90000-24Y and 61102-90020-11Y as showed in **Figure-7**. (Look at the Note-1 in page 11 for the tightening procedure.)

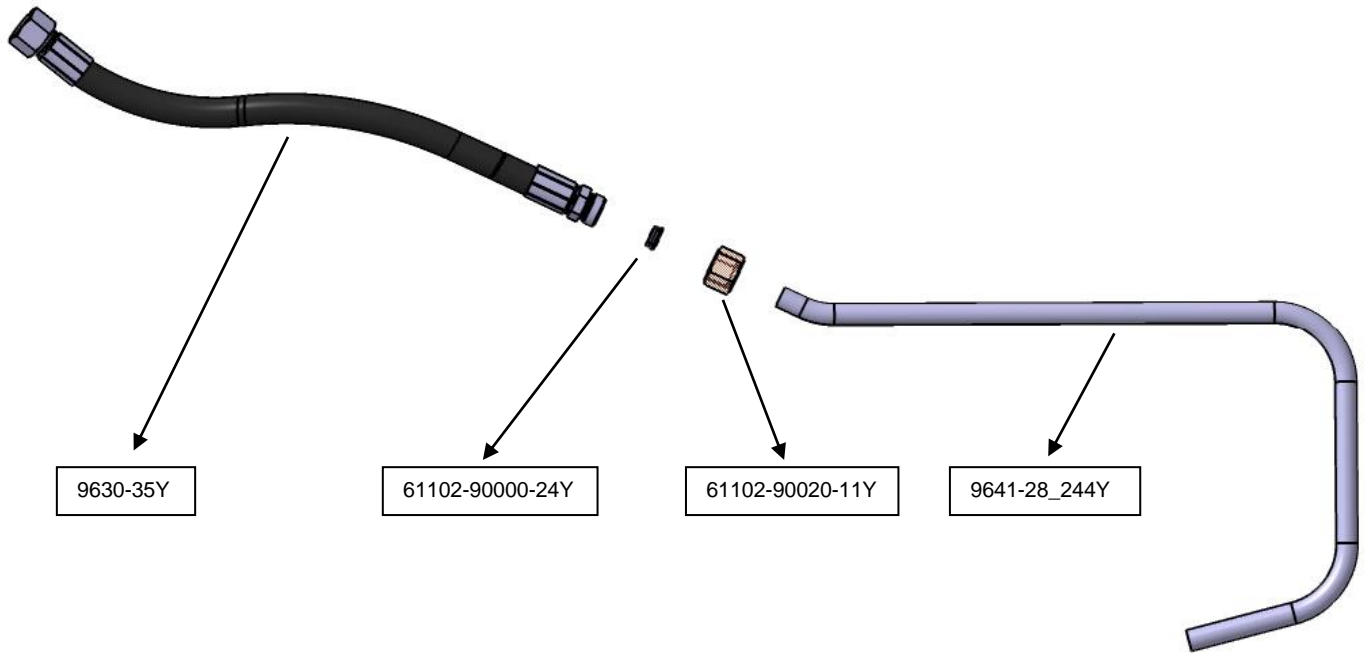


Figure-7

8. Dismount two pieces TM153298Y numbered connector (shown with blue color) and one piece 61102-90000-21Y (shown with red color) connector which is showed in **Figure-8**.

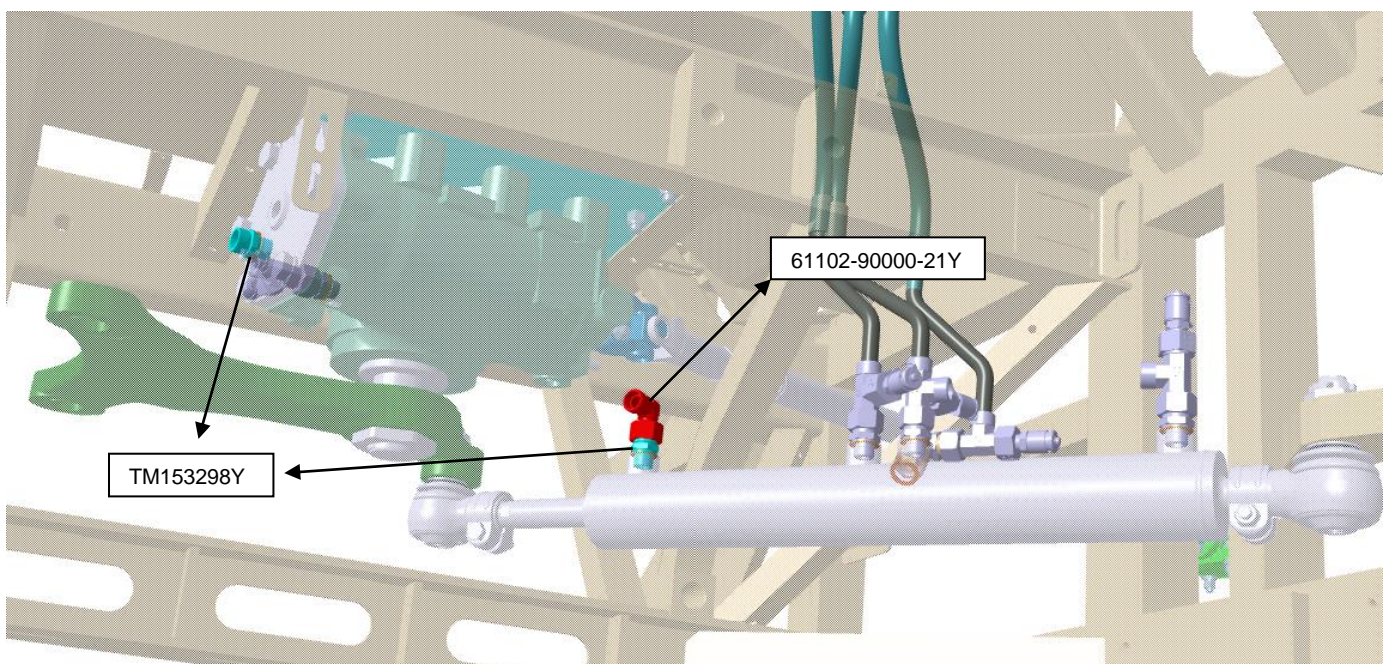
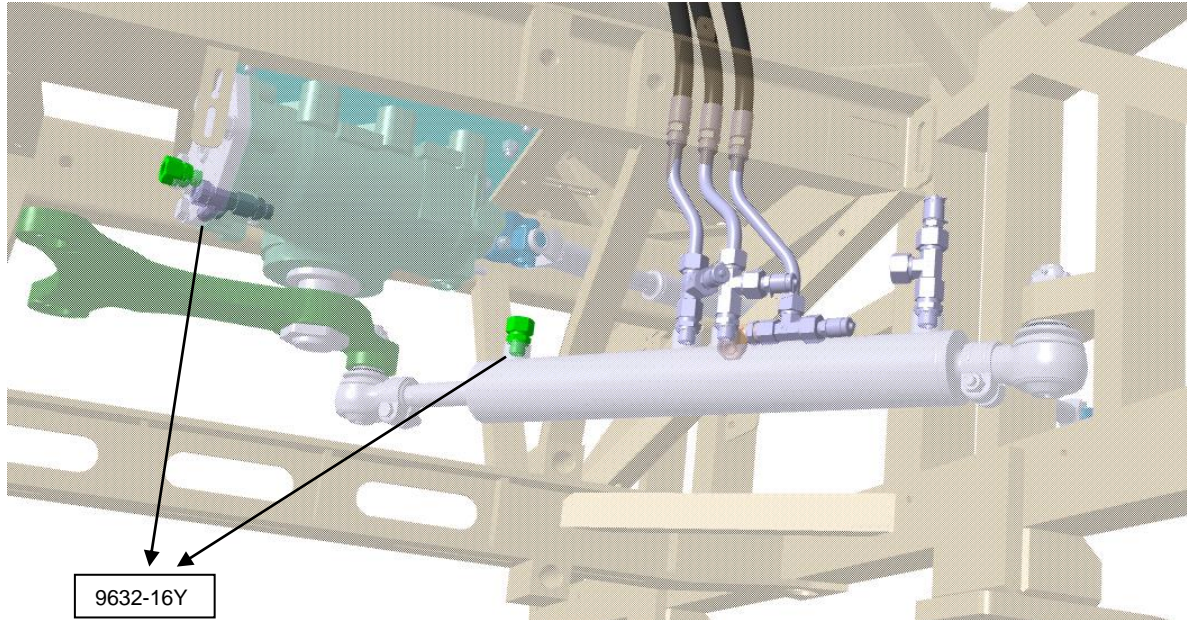


Figure-8

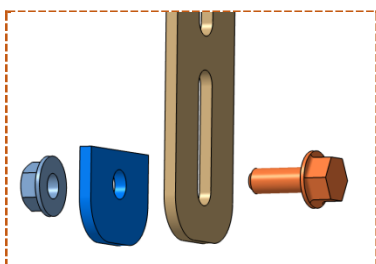
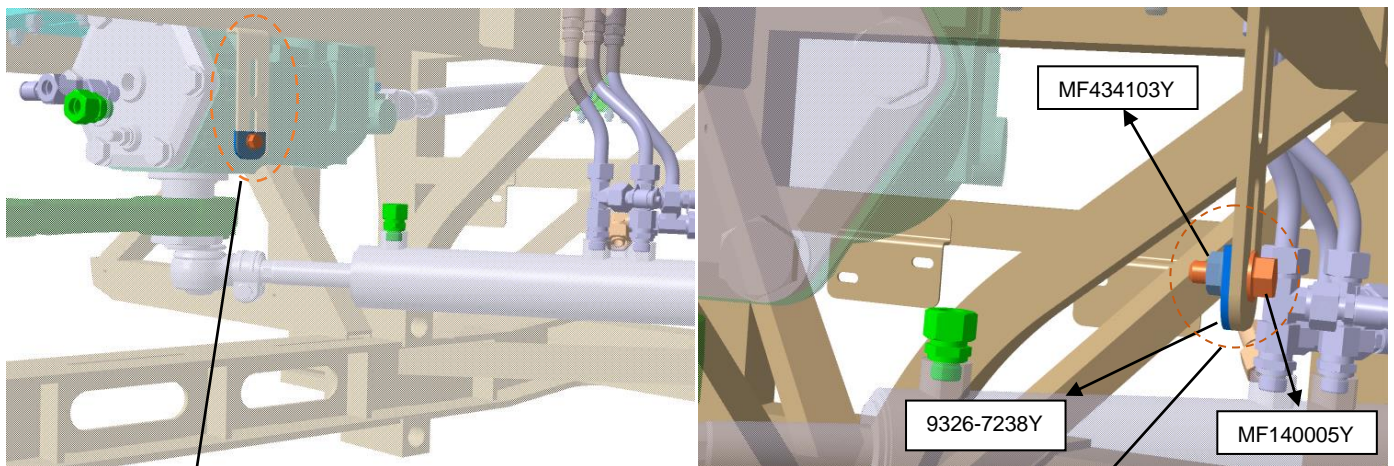


9. Mount two 9632-16Y (shown with green color) connector which is shown in **Figure-9** (Look at the Note: 1 in page 11 for the tightening procedure.)

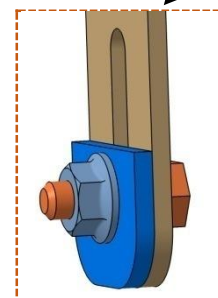


**Figure-9**

10. Mount the 9326-7238Y numbered bracket (shown with blue color in **Figure-11**) with using MF140005Y numbered bolt and MF434103Y numbered nut. (Tightening torque value is **3.69 ft-lb / 5Nm** )Then fix the 9326-7238Y by applying adhesive sealer. Bonding process must be done by applying adhesive sealer that the adherend part cannot be detached.



**Figure-10**



**Figure-11**



11. Mount hose (9630-35Y and 9641-28\_244Y) as shown in **Figure-12**. Use new 61102-90000-24Y and 61102-90020-11Y on the steering box side. (Look at the Note-1 in Page 11 for the tightening procedure.) Fix the hose and pipe on the chassis with MH020805Y numbered clip (Tightening torque value is **3.69 ft-lb / 5Nm**).

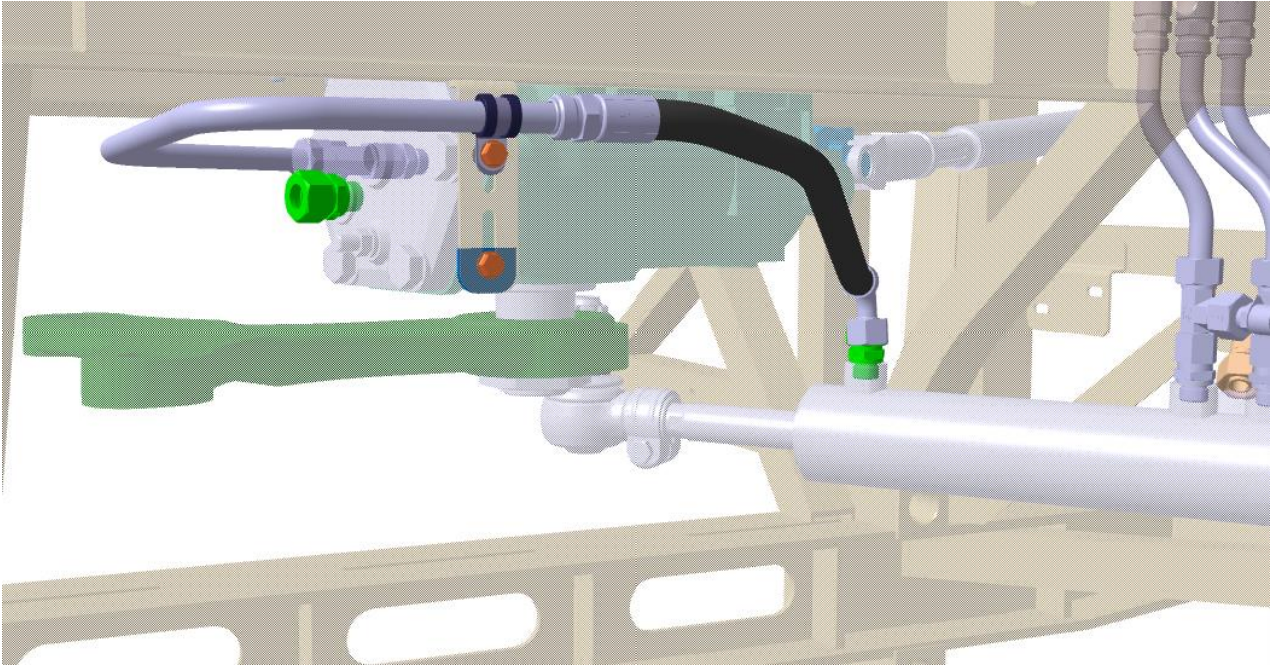


Figure-12

12. Mount 9630-36Y and 9641-28\_247Y as shown in **Figure-13**. (Look at the Note-1 in page 11 for the tightening procedure.) Use new 61102-90000-24Y and 61102-90020-11Y on the RAS cylinder connections. Fix the hose and pipe on the chassis with MH020805Y numbered clip

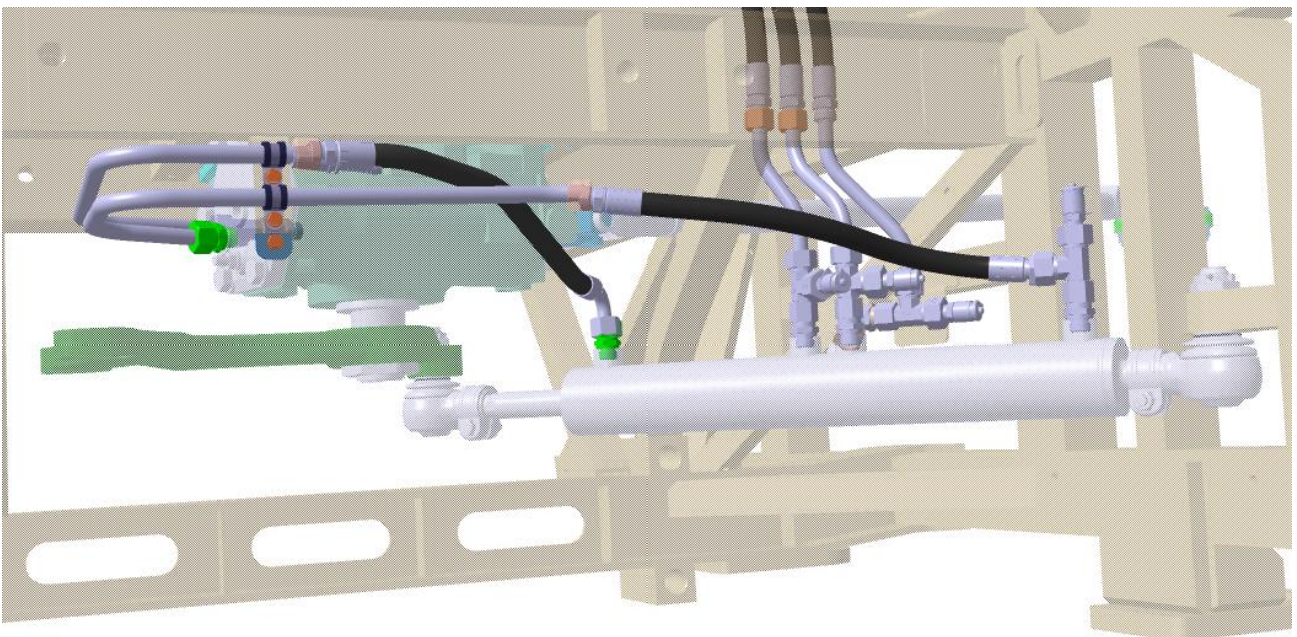


Figure-13

13. Check the steering oil level of the vehicle and fill it if necessary. Run the engine and activate the steering system. Check the oil leakage on the system. If you detect any leakage, correct and follow the steps below to bleed the system if there is no leak.

a- Run the engine.

b- Turn the steering wheel between the fully left and fully right positions approximately 10 minutes on the idle engine speed.(Check the oil level during the process and if it is needed fill the steering oil)

c- Repeat the Step-b on the max engine speed approximately 5 minutes. (Check the oil level during the process and if it is needed fill the steering oil)

d- Repeat the Step-b on the idle engine step b till the steering system work properly without any vibration effect.

**Note1:Tightening procedure for pipes connections.**

1- Lubricate thread and cone of fitting body or hardened pre-assembly tool as well as the progressive rig and nut threads.

2-Place the nut and the ferrule on the pipe. **(Figure-14)**

3- Tighten the nut by hand as much as possible.

4- Marked nut and tube to finger-tight or light wrench resistant position. **(Figure-15)**

5- Fix the connect or with a wrench and tighten the nut 1½ turns.**(Figure-16)**

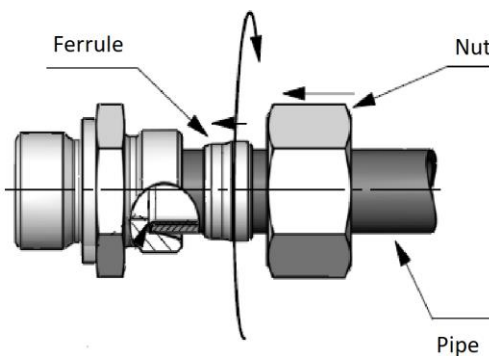


Figure-14

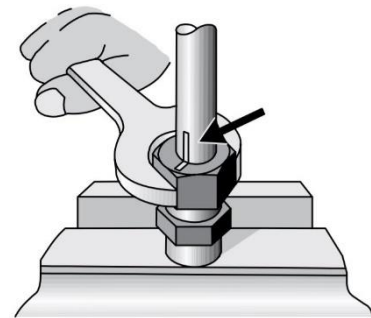


Figure-15

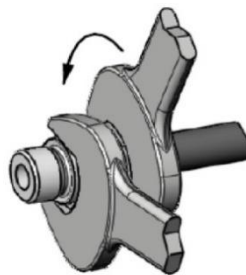


Figure-16

## FLAT RATE BREAK DOWN

Application	Time
Tool preparations	5 min
Checking and fixing of the steering hoses	115 min
<b>Total</b>	<b>120 min</b>

Safety recall TS45-SR-1901 is applicable to following units:

<p><i>To whom that will carry out this bulletin</i></p> <p>Verify vehicle eligibility by checking warranty bulletin status via TEMSA ONLINE SYSTEM</p>	
<b>Model</b>	<b>VIN</b>
TS-45	Begin: NLTEJXU88F1000002 End: NLTEJXM81J1000237
<p><b>This Safety Recall does not necessarily apply to all the above-mentioned vehicles, some vehicles may have been modified before delivery.</b></p>	