



Date: July 2013
Action No.: C1A - 130501
Group: 40

Revision	Date	Purpose
A	7/01/13	Revision to Warranty information
-	5/30/13	Initial release

**SUBJECT: Model X204 (GLK 250 BT) with AMG Styling Package 321
Model Year 2013
Install Tire Fit Kit, Replace Monroney Label**

MBUSA has initiated this Customer One Action because it has been determined that run flat tires were not installed on the affected vehicles. Due to the limited availability of run flat tires from the supplier, an authorized Mercedes-Benz dealer will install a Tirefit kit, an operator's manual supplement and a new Monroney label reflecting the installation of standard tires on all dealer inventory prior to retail sale to correct this condition. Customers with vehicles affected by this Customer One Action, retailed prior to this date, are to be contacted and a Tirefit kit, and an operator's manual supplement installed. The customer will be reimbursed by the dealer for the difference in tire costs, which may be claimed by the action.

Prior to performing this Customer One Action:
Please check VMI to insure the vehicle is involved and to determine if the vehicle has been previously repaired.

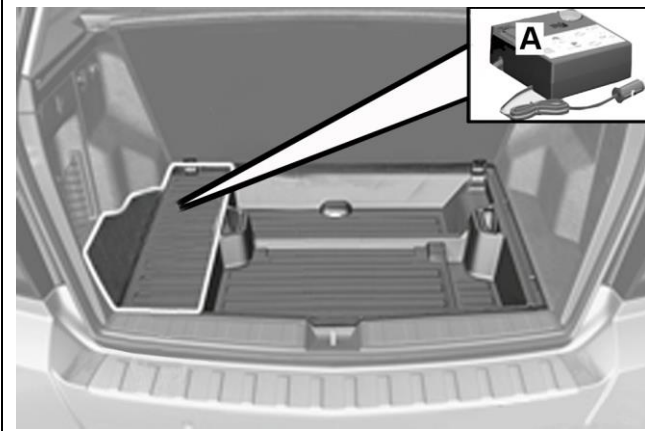

Figure 1

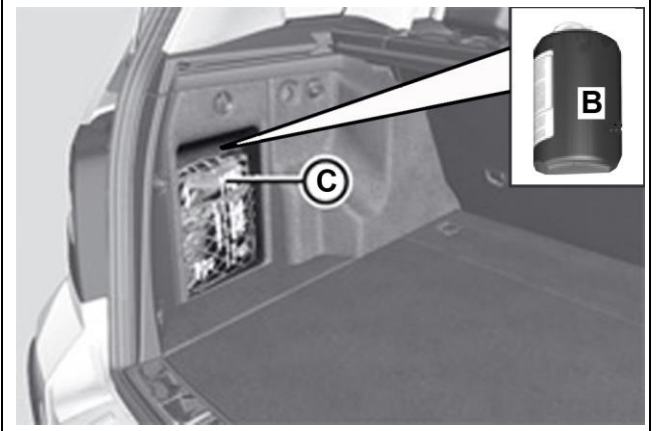

Figure 2 (C First aid kit)

Procedure

A. Inspect Vehicles in Dealer Inventory for Run Flat Tires

1. Inspect vehicle for Run Flat tires:
 - If **Yes**, Procedure is complete.
 - If **No**, proceed to step 2.
2. Check if complete Tire Fit kit consisting of: Air pump (A, Figure 1) and tire sealant container (B) is installed in luggage compartment:
 - If **both** air pump (A, Figure 1) and tire sealant container (B) are installed, proceed to step 4.
 - If air pump (A, Figure 1) and/or tire sealant container (B) are missing proceed to step 3.
3. Install missing tire fit kit items then proceed to step 4:
 - Install either air pump **or** tire sealant (depending on which one is missing) or
 - Install **both** air pump and tire sealant (if **both** are missing).
4. Affix new Monroney label to right front window and install the Operator's Manual Insert, which is the last four pages of this bulletin. Please print out, staple, fold in half and Install Operator's Manual Insert in glove box. Procedure is complete.

B. Inspect Vehicles Retailed to Customer for Run Flat Tires

1. Inspect vehicle for Run Flat tires:
 - If Yes, Procedure is complete.
 - If No, proceed to step 2.
2. Check if complete Tire Fit kit consisting of: Air pump (A, Figure 1) and tire sealant container (B) is installed in luggage compartment:
 - If **both** air pump (A, Figure 1) and tire sealant container (B) are installed, Proceed to step 4.
 - If air pump (A, Figure 1) and/or tire sealant container (B) are missing proceed to step 3
3. Install missing tire fit kit items in luggage compartment then proceed to step 4:
 - Install either air pump **or** tire sealant (depending on which one is missing) or
 - Install **both** air pump and tire sealant (if **both** are missing).
4. Operator's Manual Insert is the last four pages of this bulletin. Please print out, staple, fold in half and Install Operator's Manual Insert in glove box.
5. Provide reimbursement check to customer. Procedure is complete.

Customer Reimbursement Information

Qty.	Name	Local Purchase Number	Reimbursement Amount
1	Non Run Flat Tires	TRE 10000*	\$100

* Please claim the above local purchase number to reimburse customer for Non Run Flat Tires. The Dollar amount indicated is the amount to be reimbursed.

Primary Parts Information

Qty.	Part Name	Part Number	Estimated Replacement Rate
1	Tire pump	A000 583 1502	95%
1	Tirefit (sealant)	A000 583 0712	

Note:

- Please be aware that only the part number(s) referenced in the Customer One Bulletin is approved for use to repair the vehicle. Repairs performed using any other part(s) will not have been performed in accordance with the campaign. Accordingly, warranty claims submitted with reference to an improper part number(s) will be denied.
- The following allowable labor operation should be used when submitting a warranty claim for this repair:

Warranty Information

Operation: Check, if necessary Install tire fit kit (02-0001).

Damage Code	Operation Number	Labor Time (hrs.)
40 922 33 7	02-0001	0.2

Note:

- Please claim the above local purchase number to reimburse the customer the difference in the cost of the tire fit kit as compared to the cost of the run flat tires. The dollar amount indicated is the amount to be reimbursed to the customer.
- Operation Number labor times are subject to change

Model Year 2013 GLK-Class TIREFIT Kit Addendum

TIREFIT kit

Using the TIREFIT kit

TIREFIT is a tire sealant.

TIREFIT can be used to seal small punctures of up to 0.16 inches (4 mm), particularly on the tire tread. You can use TIREFIT at outside temperatures down to -4 °F (-20 °C).

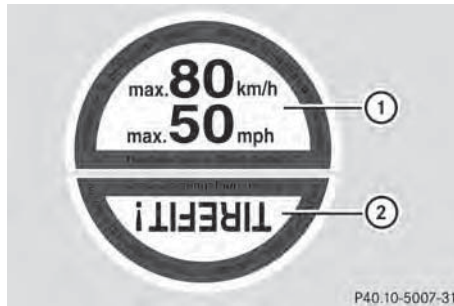

TIREFIT sticker, 2-part

- ▶ Do not remove any foreign objects which have penetrated the tire, e.g. screws or nails.
- ▶ Remove the tire sealant bottle, the accompanying TIREFIT sticker and the tire inflation compressor from the stowage well underneath the cargo compartment floor (▷ page 380).
- ▶ Affix part ① of the TIREFIT sticker within the driver's field of vision.
- ▶ Affix part ② of the TIREFIT sticker near the valve on the wheel with the defective tire.

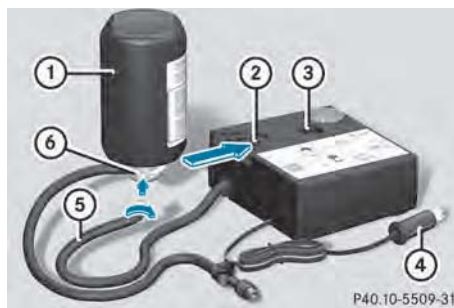

- ▶ Pull plug ④ with the cable and hose ⑤ out of the housing.
- ▶ Screw hose ⑤ onto flange ⑥ of tire sealant bottle ①.
- ▶ Place tire sealant bottle ① head downwards into recess ② of the tire inflation compressor.

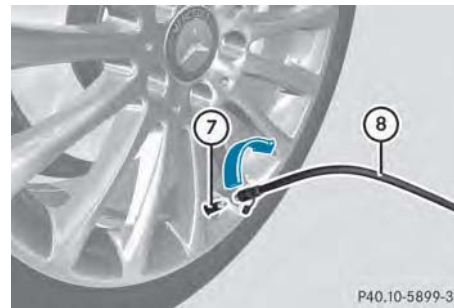

- ▶ Remove the cap from valve ⑦ on the faulty tire.
- ▶ Screw filler hose ⑧ onto valve ⑦.
- ▶ Insert connector ④ into a 12 V socket in your vehicle. Observe the notes on sockets (▷ page 347).
- ▶ Turn the SmartKey to position 1 in the ignition lock (▷ page 157).
- ▶ Press on/off switch ③ on the tire inflation compressor to I. The tire inflation compressor is switched on. The tire is inflated.

i First, tire sealant is pumped into the tire. The pressure can briefly rise to approximately 500 kPa (5 bar/73 psi).

Do not switch off the tire inflation compressor during this phase.

- ▶ Allow the tire inflation compressor to run for five minutes. The tire should then have attained a pressure of at least 180 kPa (1.8 bar/26 psi).

If a tire pressure of 180 kPa (1.8 bar/26 psi) has been attained after five minutes: (▷ page 384).

Model Year 2013 GLK-Class TIREFIT Kit Addendum

Breakdown assistance

If a tire pressure of 180 kPa (1.8 bar/26 psi) has not been attained after five minutes:
(▷ page 384).

- ❗ If tire sealant leaks out, allow it to dry. It can then be removed like a layer of film.
If your clothes are soiled with tire sealant, have them cleaned with perchloroethylene at a dry cleaner as soon as possible.

Tire pressure not reached

If a pressure of 180 kPa (1.8 bar/26 psi) has not been achieved after five minutes:

- ▶ Switch off the tire inflation compressor.
- ▶ Unscrew the filler hose from the valve of the faulty tire.
- ▶ Very slowly drive forwards or reverse approximately 30 ft (10 m).
- ▶ Pump up the tire again.
After a maximum of five minutes the tire pressure must be at least 180 kPa (1.8 bar/26 psi).

⚠ WARNING

If the required tire pressure is not reached after the specified time, the tire is too badly damaged. The tire sealant cannot repair the tire in this instance. Damaged tires and a tire pressure that is too low can significantly impair the vehicle's braking and driving characteristics. There is a risk of accident.
Do not continue driving. Contact a qualified specialist workshop.

Tire pressure reached

⚠ WARNING

A tire temporarily sealed with tire sealant impairs the driving characteristics and is not suitable for higher speeds. There is a risk of accident.
You should therefore adapt your driving style accordingly and drive carefully. Do not exceed the specified maximum speed with a tire that has been repaired using tire sealant.

- ❗ Residue from the tire sealant may come out of the filler hose after use. This could cause stains.

Therefore, place the filler hose in the plastic bag which contained the TIREFIT kit.

♻ Environmental note

Have the used tire sealant bottle disposed of professionally, e.g. at a qualified specialist workshop.

If a tire pressure of 180 kPa (1.8 bar/26 psi) has been attained after five minutes:

- ▶ Switch off the tire inflation compressor.
- ▶ Unscrew the filler hose from the valve of the faulty tire.
- ▶ Stow the tire sealant bottle and the tire inflation compressor.
- ▶ **Pull away immediately.**
The maximum speed for a tire sealed with tire sealant is 50 mph (80 km/h). The upper part of the TIREFIT sticker must be affixed to the instrument cluster in the driver's field of vision.
- ▶ Stop after driving for approximately ten minutes and check the tire pressure with the tire inflation compressor.
The tire pressure must now be at least 130 kPa (1.3 bar/19 psi).

⚠ WARNING

If the required tire pressure is not reached after driving for a short period, the tire is too badly damaged. The tire sealant cannot repair the tire in this instance. Damaged tires and a tire pressure that is too low can significantly impair the vehicle's braking and driving characteristics. There is a risk of accident.
Do not continue driving. Contact a qualified specialist workshop.

- ▶ Correct the tire pressure if it is still at least 130 kPa (1.3 bar/19 psi) (for the values, see the Tire and Loading Information

Model Year 2013 GLK-Class TIREFIT Kit Addendum

placard on the B-pillar on the driver's side or tire pressure table on the fuel filler flap).

- ▶ **To increase the tire pressure:** switch on the tire inflation compressor.

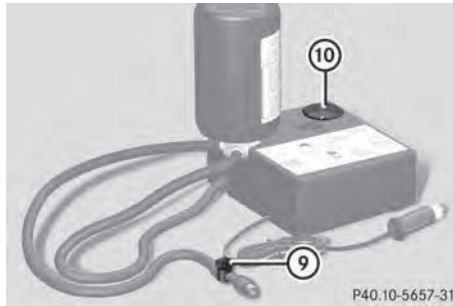

- ⑨ Pressure release button
- ⑩ Pressure gauge

- ▶ **To reduce the tire pressure:** press pressure release button ⑨ on the filler hose.
- ▶ Stow the tire sealant bottle and the tire inflation compressor.
- ▶ Drive to the nearest qualified specialist workshop and have the tire changed there.
- ▶ Have the tire sealant bottle replaced as soon as possible at a qualified specialist workshop.
- ▶ Have the tire sealant bottle replaced every four years at a qualified specialist workshop.

Battery (vehicle)

Important safety notes

Special tools and expert knowledge are required when working on the battery, e.g. removal and installing. You should therefore have all work involving the battery carried out at a qualified specialist workshop.

WARNING

Work carried out incorrectly on the battery can, for example, lead to a short circuit and damage your vehicle's electronic system. This

can disrupt driving safety systems such as ABS (anti-lock braking system) or ESP® (Electronic Stability Program).

- If ABS malfunctions, the wheels can lock during braking. This limits the steerability of the vehicle when braking and the braking distance may increase. There is a risk of accident.
- If ESP® malfunctions, the vehicle will not be stabilized if it starts to skid or a wheel starts to spin. There is a risk of accident.

You should therefore have all work involving the battery carried out at a qualified specialist workshop.

WARNING

Electrostatic build-up can lead to the creation of sparks, which could ignite the highly explosive gases of a battery. There is a risk of an explosion.

Before handling the battery, touch the vehicle body to remove any existing electrostatic build-up.

The highly flammable gas mixture forms when charging the battery as well as when jump-starting.

Always make sure that neither you nor the battery is electrostatically charged. There is a build-up of electrostatic charge, e.g.:

- by wearing clothing made from synthetic fibers
- due to friction between clothing and seats
- if you push or pull the battery across the carpet or other synthetic materials
- if you wipe the battery with a cloth.

WARNING

During the charging process, a battery produces hydrogen gas. If a short circuit occurs or sparks are created, the hydrogen gas can ignite. There is a risk of an explosion.

Model Year 2013 GLK-Class TIREFIT Kit Addendum

Equipment locations:



1 - Sealant bottle beneath First-aid kit

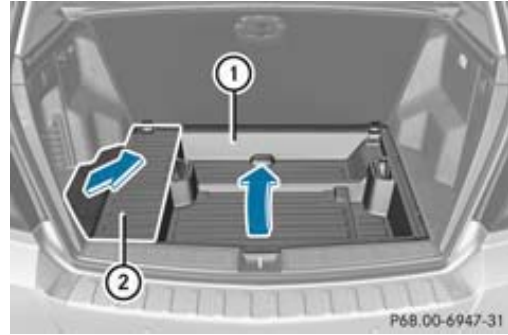

1 - Stowage tray

2 - Tire inflation compressor