

9/20/2019
CAL WS 15-001

Subject: Alison Flex Plate Mounting Bolts

Models Affected: Western Star 4700 and 4900 Model Year 2020

Our records indicate that you are the owner of certain vehicles, and DTNA has decided to share the following documentation with you.

Please see the attached communication in this email. We hope you find this information helpful.

9/2/2019
CAL WS 15-001

Work Instructions

Subject: Alison Flex Plate Mounting Bolts

Models Affected: Western Star 4700 and 4900 Model Year 2020

Bolt Replacement

1. Park the vehicle, shut down the engine, and apply the parking brakes. Chock the tires.
2. Disconnect the batteries.
3. Remove the passenger-side fender, if installed, to gain access to the starter.
4. Remove the starter cable brackets. See [Fig. 1](#).

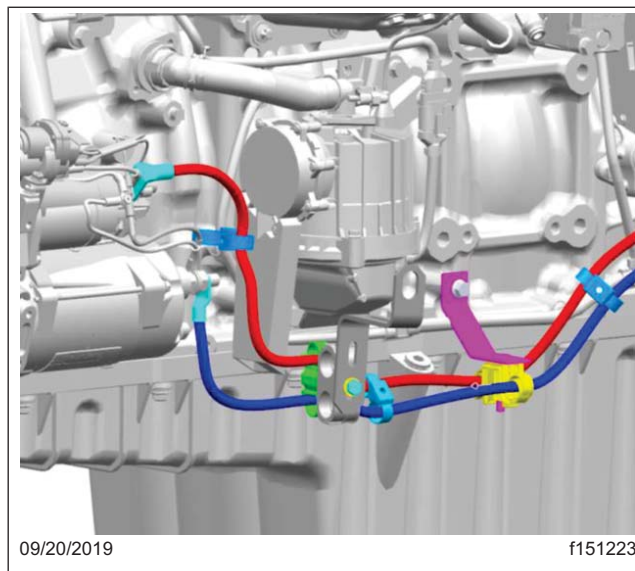

Fig. 1, Starter Cable Brackets

5. Remove the starter, with the battery cables attached, from the flywheel housing to gain access to the flex plate access plug. See [Fig. 2](#).

9/2/2019
CAL WS 15-001

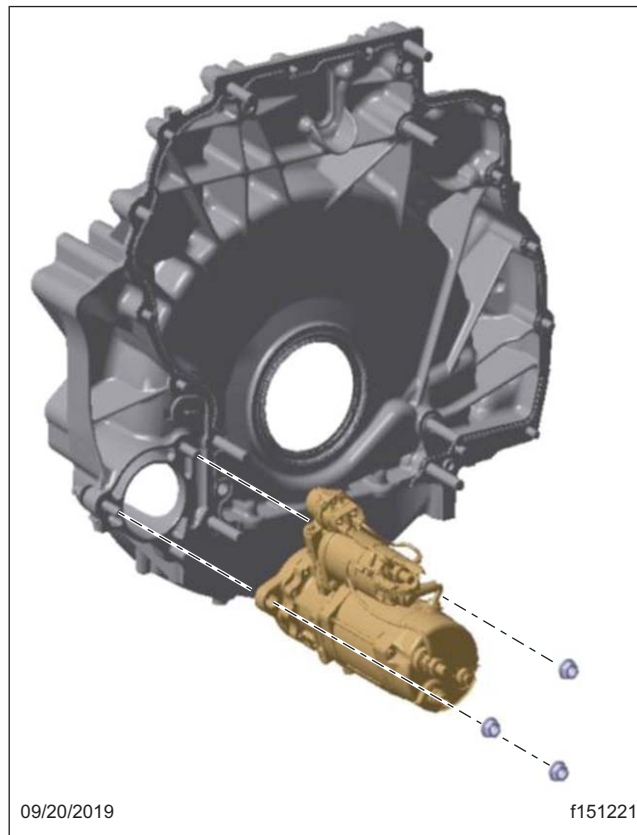

Fig. 2, Removing the Starter

6. Remove the flex plate access plug. See [Fig. 3](#).

9/2/2019
CAL WS 15-001

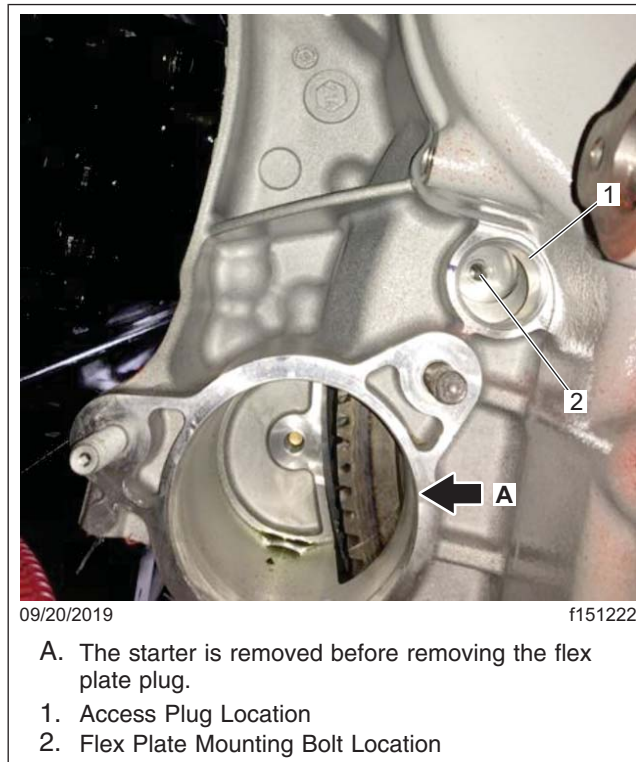

Fig. 3, Removing the Flex Plate Access Plug

7. Manually rotate the engine to align the flex plate bolt for removal through access plug location.

NOTE: Use a magnetic 8-mm socket to ensure that the bolts do not fall into the flywheel housing during removal of the existing fastener and installation of the new bolt (ALI29557752).

8. Torque the bolt to 27 lbf·ft (36 N·m). Repeat this step for all 12 flex plate mounting bolts, one at a time.
9. Install the flex plate access plug.
10. Place the starter into the mounting hole in the flywheel housing.
11. Hand start the three mounting bolts, then hand tighten them until snug. Using a torque wrench, and tighten them as follows:
 - Aluminum flywheel housing, 100 +/- 48 lbf·ft (135 +/- 65 N·m)
 - Steel flywheel housing, 137 to 147 lbf·ft (186 to 199 N·m)
12. Install the starter cable brackets. Torque cable bracket fasteners as follows:
 - M8 fasteners, 11 lbf·ft (15 N·m)
 - M10 fasteners, 22 lbf·ft (30 N·m)
13. Install the passenger-side fender, if installed. Torque fender fasteners to 15 lbf·ft (20 N·m).
14. Connect the batteries.