



Service Bulletin

Bulletin No.: 17-NA-143

Date: November, 2019

TECHNICAL

Subject: Clicking Noise from Front On Acceleration and Deceleration at Low Speeds

Brand:	Model:	Model Year:		VIN:		Engine:	Transmission:
		from	to	from	to		
Buick	Enclave	2018	2019				
Cadillac	XT5	2017					
	XTS						
Chevrolet	Traverse	2018					
GMC	Acadia (VIN N)	2017					
Holden	Acadia	2019					

Involved Region or Country	North America, Australia, Russia, Middle East, Israel, Palestine, Japan, South Korea, Columbia, Chile, Peru, North Africa and New Zealand.
Condition	Some customers may comment on a clicking noise from front wheels on Acceleration and Deceleration at low speeds.
Cause	This condition may be caused by a loss of torque on the drive axle nut.
Correction	If the above condition has been confirmed, refer to the Service Procedure section below. If the click is noted while turning at low speed, this bulletin does not apply, refer to bulletin 17-NA-271.

Service Procedure

1. Remove the front tire and wheel assembly. Refer to *Tire and Wheel Removal and Installation* in SI.

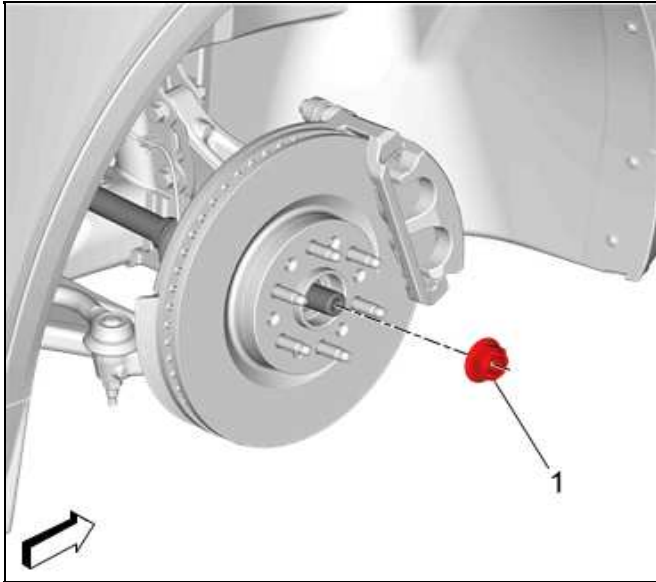

4296858

Caution: **DO NOT** use air tools to remove the wheel drive shaft nut. Damage to the wheel drive shaft threads could occur. Use hand tools only.

2. Remove the wheel drive shaft nut (1) and **DISCARD** the nut.
3. Separate the steering linkage outer tie rod from the steering knuckle.

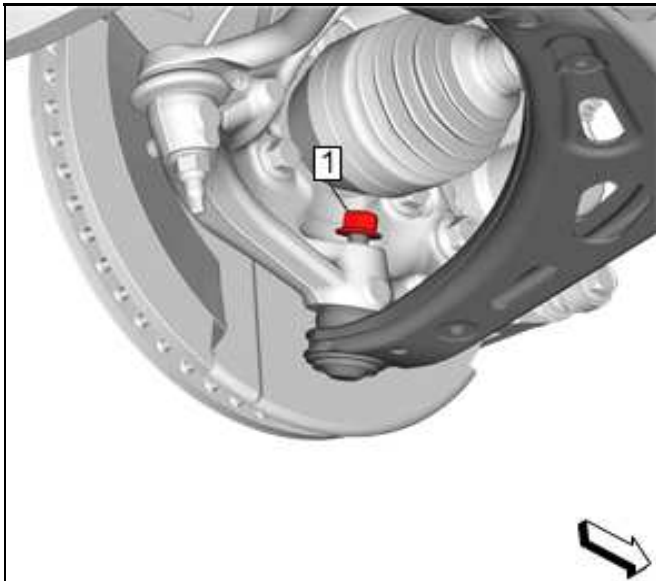

4280901

4. Remove the lower ball joint nut (1).
5. Separate the lower control arm from the steering knuckle.

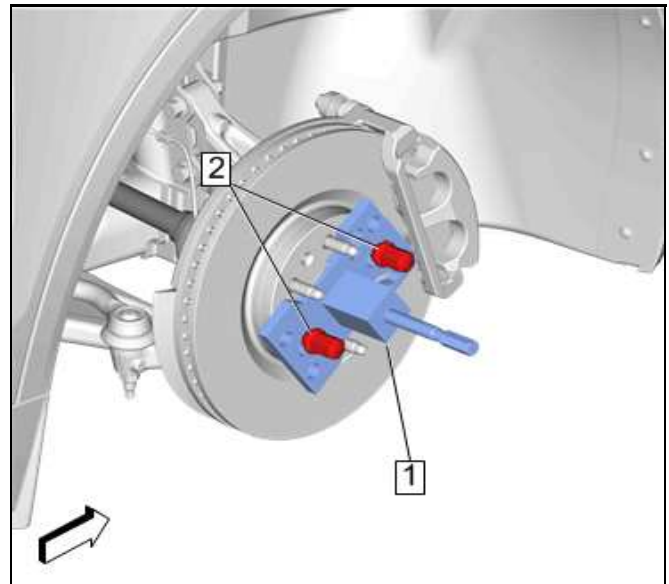

4296860

6. Attach the J-45859 remover (1) to the wheel hub using the wheel lug nuts (2).
7. Using the J-45859 remover, separate the wheel drive shaft from the wheel bearing/hub.

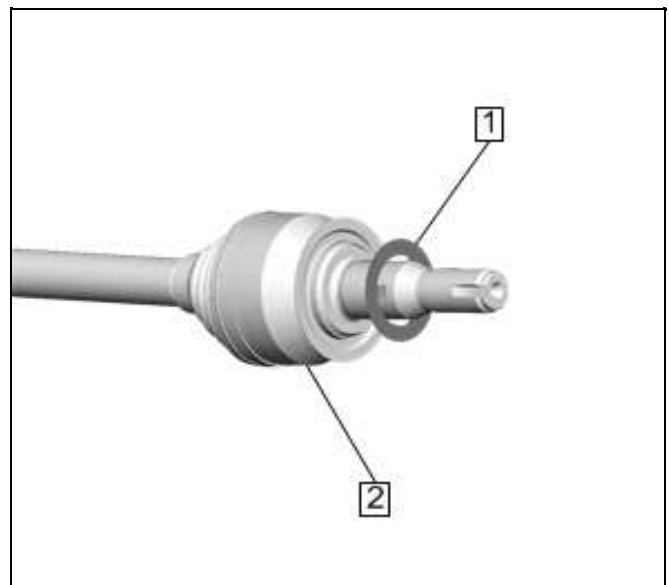

4174916

8. Remove the washer (1) from the wheel drive shaft (2) and **DISCARD** the washer.
9. Position the new washer onto the wheel drive shaft.
10. Using care, install the drive shaft into the hub.

11. Install the steering knuckle onto the lower control arm.
 - Tighten the fastener to specifications. Refer to Fastener Specifications in SI.
12. Install the outer tie rod to the steering knuckle.
 - Tighten the fastener to specifications. Refer to Fastener Specifications in SI.

Note: DO NOT use air tools to tighten the wheel drive shaft nut. Tighten the NEW wheel drive shaft nut slowly to draw the wheel drive shaft into the hub assembly prior to tightening to specifications.

13. Install new axle nut to drive shaft.
14. With the aid of an assistant holding the brake pedal down, tighten the NEW wheel drive shaft nut.
 - 14.1. First Pass: **330 N•m (244 lb ft)**
 - 14.2. Second Pass: **Loosen 45 degrees**
 - 14.3. Final Pass: **270 N•m (199 lb ft)**
15. Install the front tire and wheel assembly. Refer to *Tire and Wheel Removal and Installation* in SI.

Parts Information

Description	Part Number	Qty
Washer, FRT WHL DRV SHF	Refer to EPC	2
NUT, FRT WHL DRV SHF		2

Warranty Information

For vehicles repaired under the Bumper-to-Bumper coverage (Canada Base Warranty coverage), use the following labor operation. Reference the Applicable Warranties section of Investigate Vehicle History (IVH) for coverage information.

Labor Operation	Description	Labor Time
3080208*	Install Front Axle Shaft Nut and Washer	1.0 hr

*This is a unique Labor Operation for Bulletin use only.

Version	6
Modified	Released April 27, 2017 Revised May 30, 2017 - Added the 2018 Model Year and XTS model. Revised February 08, 2018 - Add Enclave and Traverse models. Revised February 21, 2018 - Update Parts section. Revised July 29, 2019 - Added 2019 to Model Years and Holden Acadia. Revised November 18, 2019 - Update Correction section and updated the Service Procedure section torque specification.

