



# Service Bulletin

Bulletin No.: 17-NA-233

Date: November, 2019

## TECHNICAL

**Subject: Malfunction Indicator Lamp (MIL) Illuminated - DTC P0446 Set**

Brand:	Model:	Model Year:		VIN:		Engine:	Transmission:
		from	to	from	to		
Chevrolet	Cruze	2016	2019			1.4L (LE2)	

<b>Involved Region or Country</b>	United States, Canada, Mexico, South America, Israel
<b>Condition</b>	Some customers may comment that the MIL is illuminated. Some technicians may find DTC P0446 set.
<b>Cause</b>	This condition may be caused by water trapped in the evaporative emission canister filter pipe.
<b>Correction</b>	Replace the evaporative emission canister filter pipe. ⇒ Refer to the following Service Procedure for installation of the newly designed filter pipe.

### Service Procedure

**Warning: Fuel Vapors in Evaporative Emission Components Warning**

**Warning: Safety Goggles and Fuel Warning**

1. Raise and support the vehicle. Refer to *Lifting and Jacking the Vehicle* in SI.
2. Remove the left rear wheelhouse liner. Refer to *Rear Wheelhouse Liner Replacement* in SI.

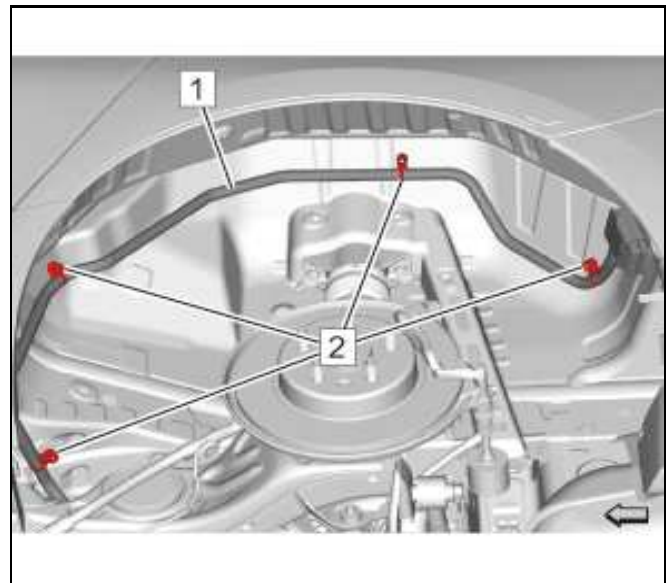

4224572

3. Using care, separate the evaporative emission canister filter pipe assembly retainers (2) from the vehicle and remove the assembly.

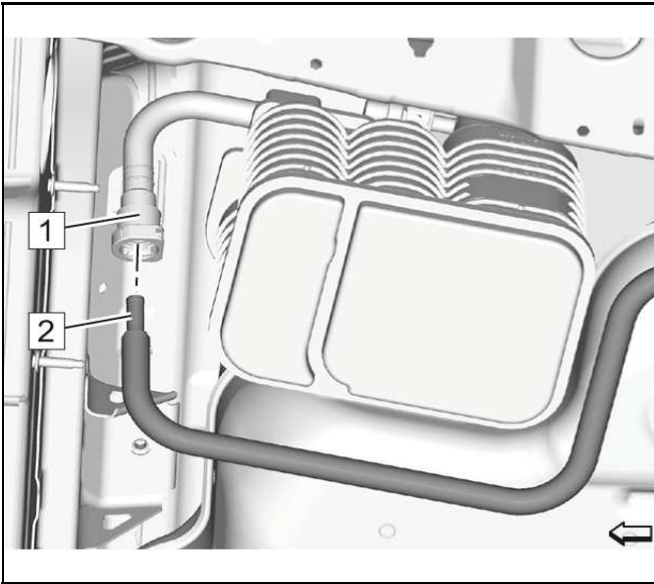

4553983

4. Disconnect the evaporative emission canister filter pipe (2) from the evaporative emission canister (1). Refer to *Plastic Collar Quick Connect Fitting Service* in SI.



5443181

5. Install the new evaporative emission canister filter pipe (1), attaching the two lower clips to the existing studs (2).
6. Connect the evaporative emission canister filter pipe to the evaporative emission canister.



5253461

7. With the evaporative emission canister filter pipe lower clips connected and the vent assembly in its relaxed position, make a mark on the panel for a new stud location for the upper clip.



5253466

8. Using a 9/32 inch drill bit, drill a hole at the mark previously made.

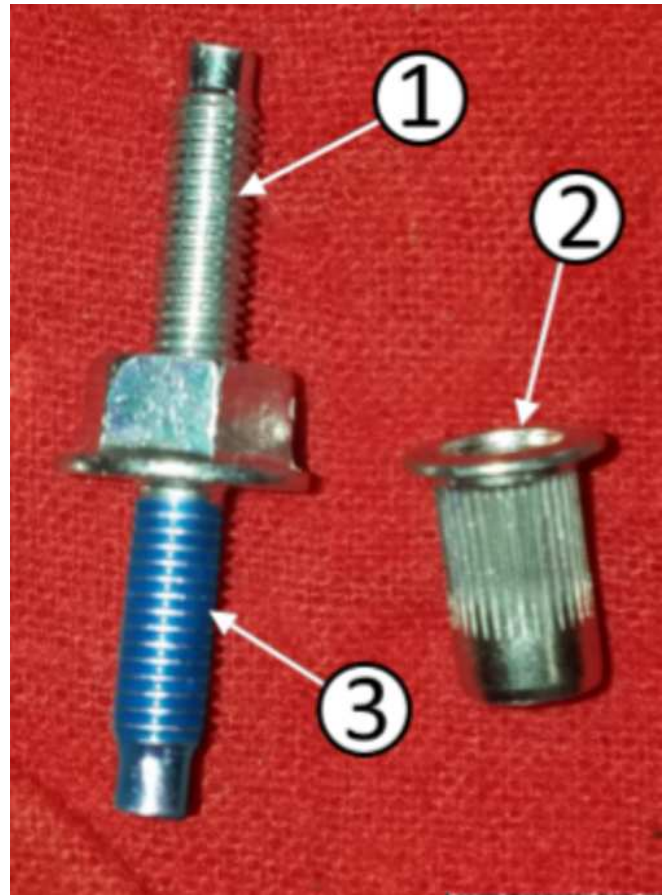

5279333

9. Add blue Loc-Tite® (3), or equivalent, to the threads of the stud (1) as shown above.
10. Using care, install the 5 mm retaining rivet (2) into the wheelhouse panel with a rivet nut installation tool.



5278656

11. Crimp the Riv-nut until secure.



5280638

12. Install the stud into the nut.

**Tighten**

Tighten the nut to 10 lb in.



5279451

13. Install the filter pipe clip to the stud.
14. Install the wheelhouse liner. Refer to *Rear Wheelhouse Liner Replacement* in SI.
15. Lower the vehicle.

**Parts Information**

Causal Part	Description	Part Number	Qty
N/A	VENT, EVAP EMIS CNSTR (2016-2017)	42708103	1
	VENT, EVAP EMIS CNSTR (2018-2019)	42703257	
	Evaporative Emissions Canister Vent Pipe Clip Stud	11603338	
	Evaporative Emissions Canister Retaining Rivet	11603351	

**Warranty Information**

For vehicles repaired under the Emission coverage, use the following labor operation. Reference the Applicable Warranties section of Investigate Vehicle History (IVH) for coverage information.

Labor Operation	Description	Labor Time
4086728*	Evaporative Emission Canister Filter Relocation	0.6 hr

\*This is a unique Labor Operation for bulletin use only.

<b>Version</b>	2
<b>Modified</b>	November 21, 2019 – Added the 2018-2019 Model Years, updated the Correction section and updated the Service Procedure, Parts Information and Warranty information sections.

