

IMPORTANT UPDATE

**TECHNICAL INSTRUCTIONS
FOR
LIMITED SERVICE CAMPAIGN K0D
FRAME CORROSION RESISTANT COMPOUND (CRC) APPLICATION
CERTAIN 2016 – 2017 MODEL YEAR TACOMA
(2011-2015 model year instructions can be found on TIS)**

COLD CLIMATE STATES ONLY

***CT, DE, IL, IN, KY, MA, MD, ME, MI, MN, NH, NJ, NY, OH, PA, RI, VA, VT, WI, WV and
District of Columbia***

UPDATE 1/23/2020

Update 1/23/20

- Wand cleaning process has been added for the wand tips in the appendix.

Update 1/10/20

- The Checksheet section was updated with details about aftermarket wax and Checksheet requirements

Update 11/15/19

- Updated browser and picture size requirements for Checksheet

The repair quality of covered vehicles is extremely important to Toyota. All dealership technicians performing this service campaign are required to successfully complete the most current version of the E-Learning course “Safety Recall and Service Campaign Essentials”. All Technicians will also be required to complete the E-Learning Module SCK0D and FTS Instructor Led course TIR019A. To ensure that all vehicles have the repair performed correctly; technicians performing this recall repair are required to currently hold at least one of the following certification levels:

- **Certified (any specialty)**
- **Expert (any specialty)**
- **Master**
- **Master Diagnostic Technician**

It is the dealership’s responsibility to select technicians with the above certification level or greater to perform this service campaign repair. Carefully review your resources, the technician skill level, and ability before assigning technicians to this repair. It is important to consider technician days off and vacation schedules to ensure there are properly trained technicians available to perform this repair at all times.



- For a complete list of Site Selection Guidelines and, Fire, Building, and Zoning Codes information for your state, please refer to the Dealer Information Packet. Please ensure your dealership complies with all regulations set forth in this packet.
- Keep records to comply with Federal/State/Local regulations and requirements. See the Federal, State & Local Requirements Guide and any Supplements to that Guide.

I. OPERATION FLOW CHART

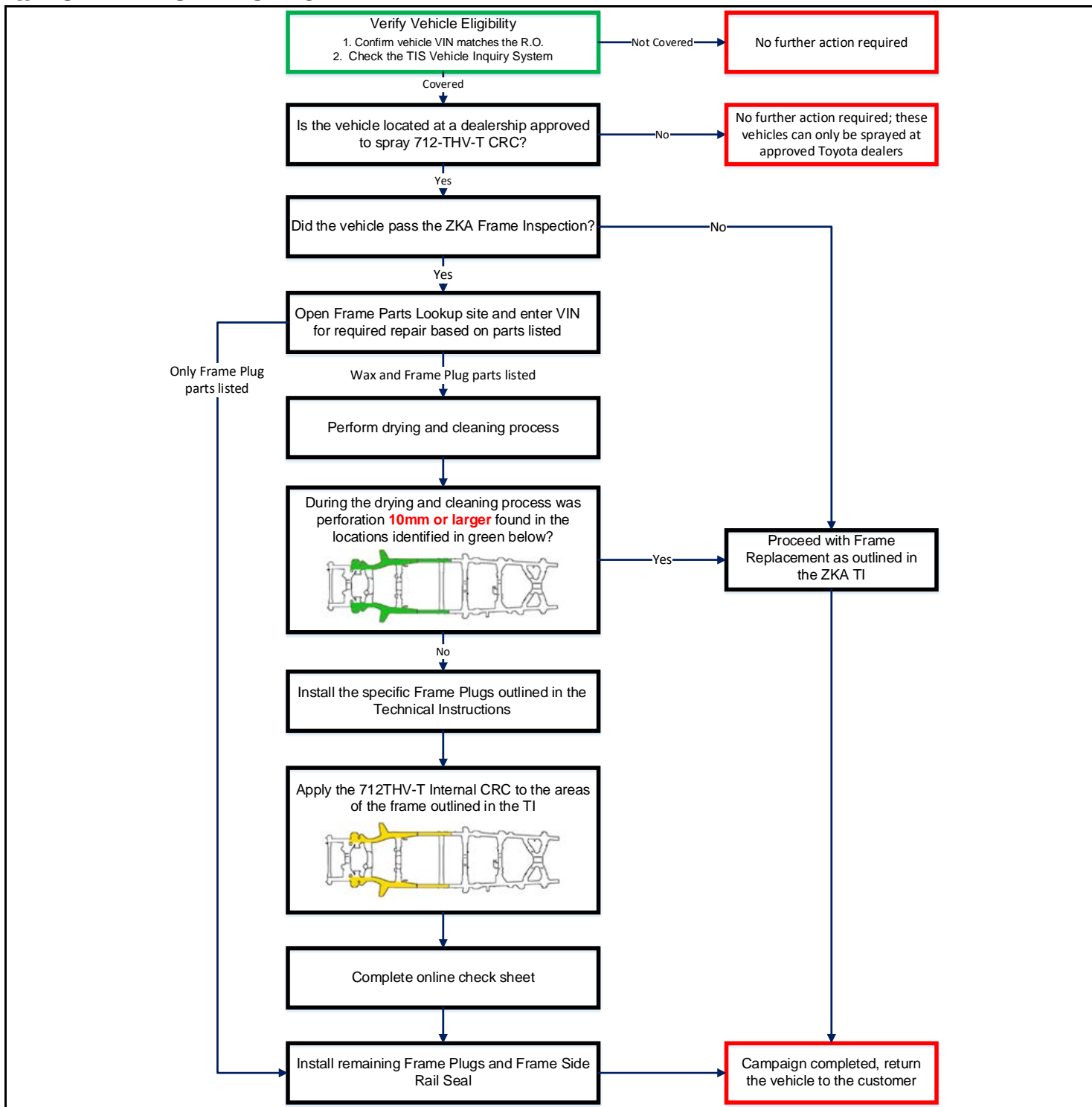

Cold Climate States include - CT, DE, IL, IN, KY, MA, MD, ME, MI, MN, NH, NJ, NY, OH, PA, RI, VA, VT, WI, WV and District of Columbia

NOTE: Ensure to follow the entire procedure and perform all steps completely any deviation will be subject to warranty claim debit.

If you find a vehicle with aftermarket wax already applied to the interior of the frame, contact Quality_Compliance@toyota.com for guidance

II. IDENTIFICATION OF AFFECTED VEHICLES

A. COVERED VIN RANGE

NOTE:

- Vehicles currently registered in the Cold Climate States* or the District of Columbia (D.C.) that do not have significant corrosion found are eligible for Corrosion-Resistant Compound (CRC) application to the frame if it did **NOT** previously have the frame sprayed and/or had the frame previously replaced.
- Check TIS to confirm the VIN is covered in K0D. This will verify the vehicle is covered and has not already been completed prior to dealer shipment or by another dealer.
- TMNA warranty will not reimburse dealers for repairs conducted on vehicles that are not covered or were completed by another dealer.
 - * *CT, D.C. , DE, IL, IN, KY, MA, MD, ME, MI, MN, NH, NJ, NY, OH, PA, RI, VA, VT, WI, & WV*
- If the vehicle is regular operated or registered in a cold climate state but is not included in K0D contact Quality Compliance for instructions on how to include the vehicle in K0D

III. PREPARATION

A. PARTS

To assist dealers in determining the correct part number(s) to order, a website has been set up to look up part numbers by VIN. Please go to <https://tacoma-2011-2017-frames.imagespm.info/> select the appropriate campaign/vehicle, enter the VIN, and the correct part numbers to order will be displayed. ***The website is for part(s) application reference only and won't order the parts, confirm campaign completion status, or confirm campaign applicability.***



Based on the results shown in the parts look up site you will be able to determine if the vehicle needs wax application or not. Confirm what parts are listed in the site shown above before proceeding

A. WAX

Part Number	Part Name	Qty
00289-TS00P	WAX (18 Liters PAIL CAN)	4.5L (Per Vehicle)

B. SUPPORT MATERIALS

Individual Parts:

Part Number	Part Name	Model Year	Qty
90950-01987	Plug, Hole	2011-2017	2

Parts Kits:

Part Number	Part Name	Model Year	Qty	
04008-07835	Plug Hole Kit CRC Application 2	2016-2017	1	
The kit above includes the following parts:				
Part Number	Part Description	Qty		
90950-01A24	Plug, Hole	2		
90950-01A25		2		
90950-01987		4		
90950-01631		4		
90950-01990		2		
90950-01991		2		
90950-01931		1		
90333-30002		Plug, Plate	4	
94183-00831		Nut, Lock	2	
94611-10800		Washer, Plate	4	

Part Number	Part Name	Model Year	Qty
04008-21204	Plug Hole Kit CRC Application 4	2016-2017	1
The kit above includes the following parts:			
Part Number	Part Description	Qty	
90950-A1008	Plug, Hole	2	
90950-A1009		2	
90080-46327	Clip	2	
5114A-04010	Seal, Frame Side Rail, RH	1	
5114B-04010	Seal, Frame Side Rail, LH	1	
90178-A0112	Nut, Flange	2	
90105-A0356	Bolt, Flange	2	

C. STANDARD TOOLS & EQUIPMENT

- Standard hand tools
- Torque wrench

SPECIAL EQUIPMENT

The following equipment was shipped to your dealership prior to the launch of LSC K0D.

Equipment	Purpose	Application Area																		
Drying Equipment Kit	Drying	Interior / Open Section Frame Drying																		
*Drying Kit Includes																				
<table border="1" style="width: 100%; border-collapse: collapse;"> <thead> <tr> <th style="width: 70%;">Equipment</th> <th style="width: 30%;">Qty</th> </tr> </thead> <tbody> <tr> <td>Air Mover</td> <td style="text-align: center;">1</td> </tr> <tr> <td>E-TES Heater</td> <td style="text-align: center;">1</td> </tr> <tr> <td>Air Duct Plate</td> <td style="text-align: center;">1</td> </tr> <tr> <td>Air Duct Plugs</td> <td style="text-align: center;">2</td> </tr> <tr> <td>Air Duct Hoses</td> <td style="text-align: center;">2</td> </tr> <tr> <td>Air Duct Adapters</td> <td style="text-align: center;">2</td> </tr> <tr> <td>4in Hose Clamps</td> <td style="text-align: center;">4</td> </tr> <tr> <td>3in Hose Clamps</td> <td style="text-align: center;">2</td> </tr> </tbody> </table>			Equipment	Qty	Air Mover	1	E-TES Heater	1	Air Duct Plate	1	Air Duct Plugs	2	Air Duct Hoses	2	Air Duct Adapters	2	4in Hose Clamps	4	3in Hose Clamps	2
Equipment	Qty																			
Air Mover	1																			
E-TES Heater	1																			
Air Duct Plate	1																			
Air Duct Plugs	2																			
Air Duct Hoses	2																			
Air Duct Adapters	2																			
4in Hose Clamps	4																			
3in Hose Clamps	2																			
*There will be 2 silver colored hoses that will be included in the kit but will not be used in the campaign procedure																				
Cleaning Equipment Kit	Cleaning	Interior / Open Section Frame Drying and Cleaning																		
*Cleaning Kit Includes																				
<table border="1" style="width: 100%; border-collapse: collapse;"> <thead> <tr> <th style="width: 70%;">Equipment</th> <th style="width: 30%;">Qty</th> </tr> </thead> <tbody> <tr> <td>Power Tool Wire Brush</td> <td style="text-align: center;">1</td> </tr> <tr> <td>Power Tool Wand</td> <td style="text-align: center;">1</td> </tr> <tr> <td>PVC Handle</td> <td style="text-align: center;">1</td> </tr> <tr> <td>Extended Wire Brush</td> <td style="text-align: center;">1</td> </tr> <tr> <td>2ft Air Gun</td> <td style="text-align: center;">1</td> </tr> </tbody> </table>			Equipment	Qty	Power Tool Wire Brush	1	Power Tool Wand	1	PVC Handle	1	Extended Wire Brush	1	2ft Air Gun	1						
Equipment	Qty																			
Power Tool Wire Brush	1																			
Power Tool Wand	1																			
PVC Handle	1																			
Extended Wire Brush	1																			
2ft Air Gun	1																			
Wand Kit	712THV-T Wax Application	Interior Frame CRC Application.																		
*Wand Kit Includes																				
<table border="1" style="width: 100%; border-collapse: collapse;"> <thead> <tr> <th style="width: 70%;">Equipment</th> <th style="width: 30%;">Qty</th> </tr> </thead> <tbody> <tr> <td>Short Wand</td> <td style="text-align: center;">1</td> </tr> <tr> <td>Long Wand</td> <td style="text-align: center;">1</td> </tr> <tr> <td>LH Guide Plug</td> <td style="text-align: center;">1</td> </tr> <tr> <td>RH Guide Plug</td> <td style="text-align: center;">1</td> </tr> </tbody> </table>			Equipment	Qty	Short Wand	1	Long Wand	1	LH Guide Plug	1	RH Guide Plug	1								
Equipment	Qty																			
Short Wand	1																			
Long Wand	1																			
LH Guide Plug	1																			
RH Guide Plug	1																			
Wax Application Spray Package	712THV-T Wax Application	Interior Frame CRC Application.																		
*Wax Application Spray Package Includes																				
<table border="1" style="width: 100%; border-collapse: collapse;"> <thead> <tr> <th style="width: 70%;">Equipment</th> <th style="width: 30%;">Qty</th> </tr> </thead> <tbody> <tr> <td>Pump and Heater Assembly</td> <td style="text-align: center;">1</td> </tr> <tr> <td>TSL Bottle</td> <td style="text-align: center;">1</td> </tr> <tr> <td>Owner's Manual</td> <td style="text-align: center;">1</td> </tr> </tbody> </table>			Equipment	Qty	Pump and Heater Assembly	1	TSL Bottle	1	Owner's Manual	1										
Equipment	Qty																			
Pump and Heater Assembly	1																			
TSL Bottle	1																			
Owner's Manual	1																			

The items below were previously shipped to your dealership for previous campaign (H0F and J0M).

Equipment	Purpose	Application Area
90° Drill Adapter	Drill Holes	These tools will be used to attach the Frame Side Rail Seal.
Drill Bits		
J0M Endoscope	Inspect Frame	Interior Frame Sections

D. MATERIALS & SUPPLIES (Locally Procured by Dealer)

- Wire Brush
- C-Clamp
- Bungee Cord / Strap
- Protective eyewear
- Air Coupler
- Gasket Scraper
- Dust mask
- Appropriate NIOSH approved respirator** (Follow all Federal, State, Local Environmental, Health and Safety Requirements such as OSHA Regulations. Please refer to the SDS for details on the appropriate mask for each CRC.)



Example of a NIOSH-approved respirator

****NOTE:**

- Refer to the SDS located in the Appendix for additional information on respirator use.
- It is up to the individual dealership to ensure compliance with OSHA regulations.
- If you require further assistance in regards to NIOSH approved respirators, we have found 3M® to be a useful reference/source.

3M® Technical Assistance: 1-800-243-4630
3M® Customer Service: 1-800-328-1667
3M® Web Site: www.3m.com/occsafety

- Protective gloves
- Chemical Resistant Gloves (refer to SDS for specific type)
- Masking tape
- Duct tape
- Plastic wrap (for storage of wands, guns and wax pail)
- Shop cloth/paper towels
- Garbage Bags
- Paint Prep Cup (Φ 10-15cm (3.94 - 5.91 in.) for paint work. This cup will be used to check wax application.)

E. SPACE

1 stall (with swing arm lift) + α (for wax application system space)

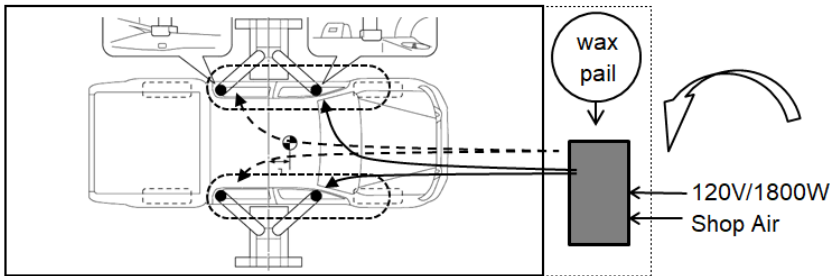

IV. BACKGROUND

Toyota has received a number of reports regarding frame corrosion perforation on 2011 – 2017 model year Tacoma vehicles. In these reports, customers have indicated that vehicles operated in specific cold climate areas with high road salt usage may exhibit more-than-normal corrosion to the vehicle's frame. This condition is unrelated to and separate from normal surface rust which is commonly found on metallic surfaces after some years of usage and/or exposure to the environment.

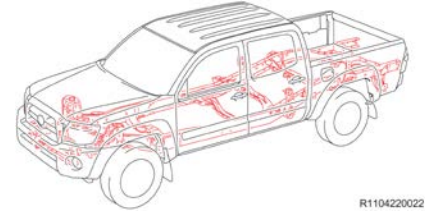

V. VEHICLE INSPECTION WORK PROCEDURE

NOTE:

Vehicle frame inspection is performed under CSP ZKA, for inspection instructions go to CSP ZKA Frame Replacement Technical Instructions.



- Because of variations in State and local laws, dealerships conducting KOD in certain states may require government approvals prior to starting the campaign. Depending upon the state, dealerships also may be subject to restrictions on the number of vehicles to which the CRC can be applied in any single day, week, or month. Please refer to the Dealer Information Packet and any Supplements for important information about any such approvals or restrictions that may apply to your dealership. Your dealership must adhere strictly to these requirements.
- For a complete list of Site Selection Guidelines, Fire, Building, and Zoning Codes information for your state, please refer to the Dealer Information Packet as well as any Supplements. Please ensure your dealership complies with all regulations and all issued packets/instructions.

VI. OTHERS

1. PRECAUTIONS WHEN HANDLING THE HIGH PRESSURE SYSTEMS

- When the spray equipment, sealer gun or the wand tips are clogged, leaking, abnormal noise, etc., please **DO NOT** operate the equipment and contact the following:
Bosch Technical Assistance Line - 1-800-933-8335 (Option 4)
- Be careful as you are using the high pressure spray gun. Always follow the instructions and observe the specified pressures. **NEVER** operate the pressure regulators to be over the specified values. e.g. **DO NOT** try to blow out the wand or tip clogging by high-pressure air. It may result in splashing out wax or breaking the wand or hose, and the scattered broken parts may cause serious injuries.
- Make sure to check for leakage or breakage before each use. If any problems are found, stop using the system immediately and please contact the following:
Bosch Technical Assistance Line - 1-800-933-8335 (Option 4)
- DO NOT** disassemble the parts other than the short wand or the long wand.

VII. PRECAUTIONS WHEN HANDLING WAX

- Attention should be paid as the wax is very slippery.
- Wipe off the wax on the floor and shoes promptly to not slip and fall.
- Perform work in a well-ventilated area.
- Always work with clean tools and hands.

VIII. PRECAUTIONS WHEN USING APPLICATION SYSTEM

- Attention should be paid to **NOT** get caught as the application hose is long and hard.
- DO NOT** bend or modify hoses or piping.
- Pay attention to the position of the system.

IX. KEEP YOUR WORK SPACE ORGANIZED

- DO NOT** place removed parts or unused items such as wands on the floor.

X. CONTACT INFORMATION FOR TROUBLESHOOTING

For any issues with the Spray Wax/Cleaning equipment contact your FTS for assistance. If your FTS is not available, contact the *Bosch Technical Assistance Line - 1-800-933-8335 (Option 4)* for assistance.

VII. VEHICLE PREPARATION

1. LIFT UP THE VEHICLE

- a) Decide the center of gravity and support positions according to the repair manual on TIS.

NOTE:

Observe the instructions of the lift manual.

When using a swing arm with a plate, set the position of the plate to the rear (set by extending the arm).

Avoid the application hole.

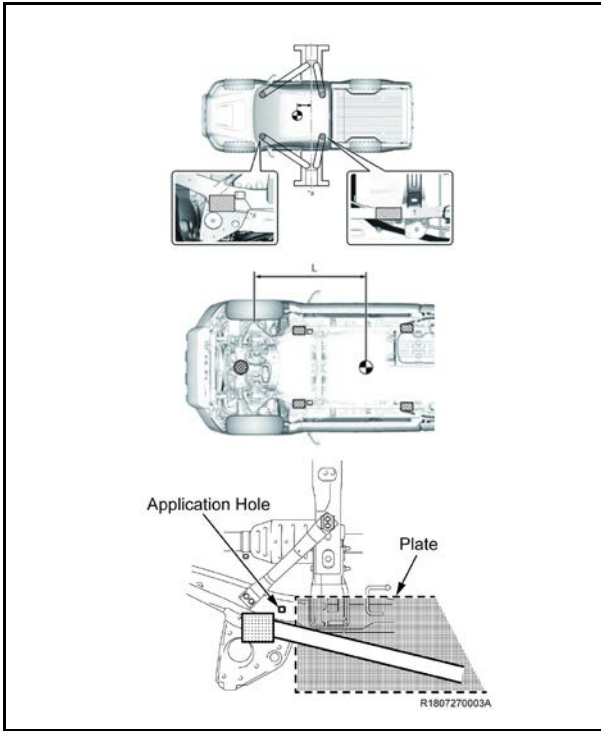

2. REMOVE THE FRONT SUSPENSION MEMBER BRACKET (IF EQUIPPED)

- b) Remove the front suspension member bracket.

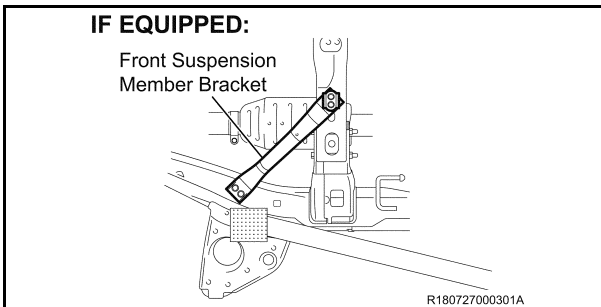

VIII. DRILL HOLE FOR FRAME RAIL SEAL

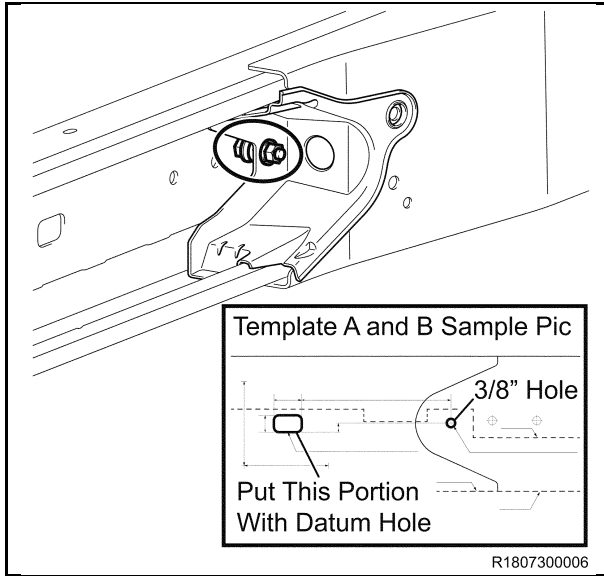

1. DRILL HOLE FOR FRAME RAIL SEAL

NOTE:

You may not have to drill a hole as some models will already have a threaded hole for the bolt. Inspect for a threaded hole before you begin the next steps.

- Using Template A and B in the appendix, locate the location on both outer frame side rails.
 - Print the Template
 - Cut the template out
 - Align the template with the datum hole
 - Mark location of hole on outer frame side rail
- Use a center pin punch to create a dimple for the drill bit so it will not wander during drilling.
- Using the 90° drill adapter provided and the stepper bit, drill a 9mm (3/8") hole in the outer frame side rail as shown.
- Repeat procedure for opposite side frame rail.

IX. DRYING INITIAL SETUP (Required for initial setup only)



Before starting this process, review the SCK0D E-Learning Drying section for key details



1. INSTALL THE AIR MOVER INTO THE E-TES HEATER

- Push the air mover into the E-TES heater. Ensure the air mover is fully seated into the E-TES heater



2. INSTALL THE AIR DUCT PLATE ONTO THE E-TES HEATER

- Using the 4in hose clamps, attach the air duct plugs into the ends of the air duct plate.

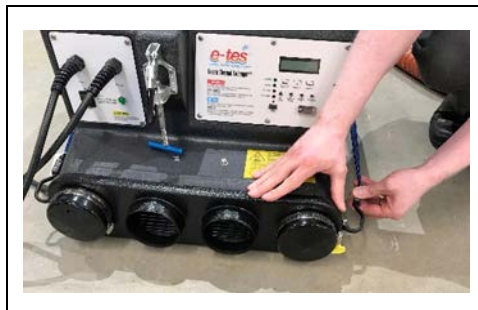

- Install the air duct plate to the front of the E-TES heater and secure it with a bungee cord attached around the E-TES heater



3. ATTACH AIR DUCT HOSES TO E-TES HEATER

- a. Install 4in hose clamp to the air duct adapter. Do this to both air duct adapters.



- b. Attach the air duct adapter to the air duct hose using the 3in hose clamp. Do this to both adapters and both hoses

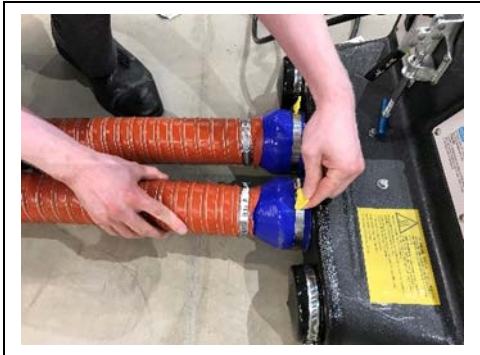

- c. Install air duct adapters and hoses to the air duct adapter plate.



4. ATTACH HEATER TO VEHICLE

- a. Lift the vehicle
- b. Place the E-TES heater below the rear of the vehicle.
- c. Connect the air mover power cord and the two E-TES heater power cords (if not already connected)

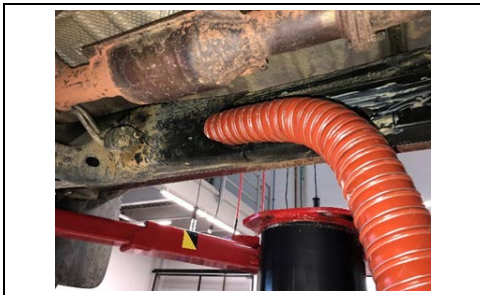

- d. Insert the right-side hose into the right-side frame rail until it is secure.



- e. Using a bungee cord or straps around the frame rail, secure the left-side hose to the left side frame rail. The outlet of the hose must be center with the frame rail opening.



DO NOT wrap the bungee cord around any fuel, evap, or brake hoses. Only put the bungee cord around the frame rail and air duct hose to avoid damage to vehicle components.

5. CALIBRATE E-TES HEATER

- a. Plug in the air mover power cord and the two E-TES heater power cords.



The air mover and E-TES heater must be plugged into separate circuits. Check your dealership electrical system to ensure the circuit you are plugging into can operate the air mover and E-TES heater.



- b. Press SELECT to set the Air Flow switch trigger point. Follow the screen directions using the DOWN button to set the levels with the air mover OFF & ON.

- c. Turn the air mover OFF. When the air mover is off and the number stops changing, press DOWN (most cases this will be 0.) This is the Off Set Point. (Shown as 033 in this example)

- d. Then turn the air mover ON at high speed. Press DOWN as soon as the number on the display steadies out (50-300). This is the ON Set Point. (Shown as 076 in this example)



If you need assistance with the E-TES heater contact the Bosch Technical Assistance Line - 1-800-933-8335 (Option 4)

DO NOT CONTACT TAS for E-TES Heater concerns.

X. DRYING PROCEDURE (Normal procedure after initial setup)



1. ATTACH HEATER TO VEHICLE

- a. Lift the vehicle
- b. Place the E-TES heater below the rear of the vehicle.
- c. Connect the air mover power cord and the two E-TES heater power cords (if not already connected)



- d. Insert the right-side hose into the right-side frame rail until it is secure.



- e. Using a bungee cord or straps around the frame rail, secure the left-side hose to the left side frame rail. The outlet of the hose must be center with the frame rail opening.



DO NOT wrap the bungee cord around any fuel, evap, or brake hoses. Only put the bungee cord around the frame rail and air duct hose to avoid damage to vehicle components.



2. TURN THE AIR MOVER ON THE HIGH SETTING

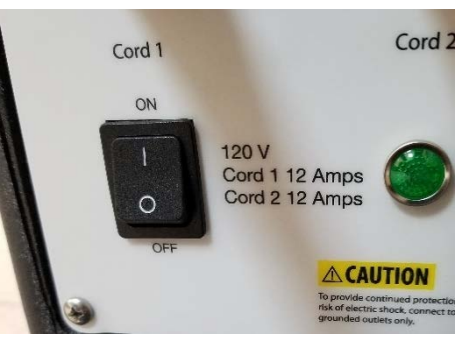

3. TURN THE E-TES HEATER ON AND DRY FRAME

- a. Flip the switch on the E-TES Heater to the “on” position
- b. Check that the air coming out of the heater is warm.
- c. Leave the heater and air mover ON and attached to the vehicle for **3 hours**.



The drying procedure being performed as written is critical for the wax application procedure success. If the drying procedure is not performed correctly the maximum rust prevention will not be achieved.

4. REMOVE E-TES HEATER AND HOSES FROM VEHICLE

5. DRY THE OPEN SECTION OF THE FRAME AND INNER CAB MOUNTS

- a. Using the 2ft air gun, remove all water from the open section of the frame and the inside of the cab mounts on both the right and left side of the frame. All the water between the metal reinforcements in the open section of the frame **MUST BE REMOVED** before proceeding

IT IS CRITICAL THAT YOUR SHOP AIR SYSTEM NOT HAVE WATER IN IT.



Confirm by spraying the air gun at a piece of cardboard (or other water absorbant material) to confirm that no water is present. If water is present then the shop air dryer may need to be drained or replaced.

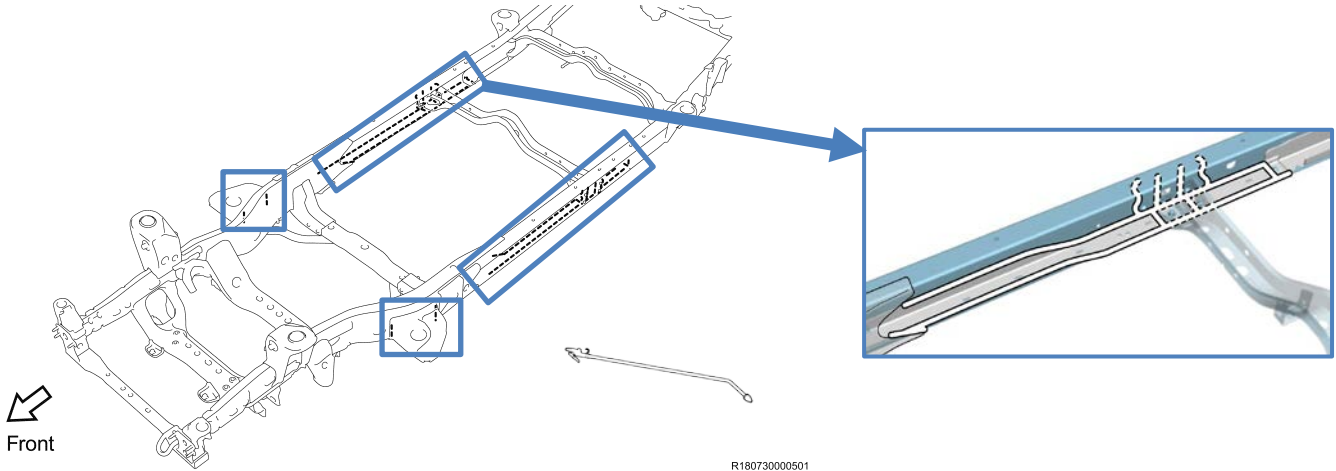

XI. 16-17 MODEL YEAR CLEANING PROCEDURE



Before starting this process, review the SCK0D E-Learning Cleaning section for key details

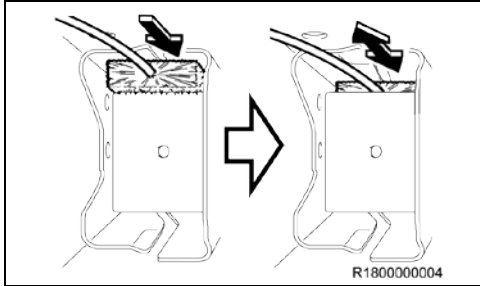

1. **USE EXTENDED WIRE BRUSH TO CLEAN THE INSIDE OF THE RH FRAME RAIL BOXED SECTION**
 - a. Insert the brush into the frame rail as shown in the image/illustration. Push the brush past the top of the box inside the frame

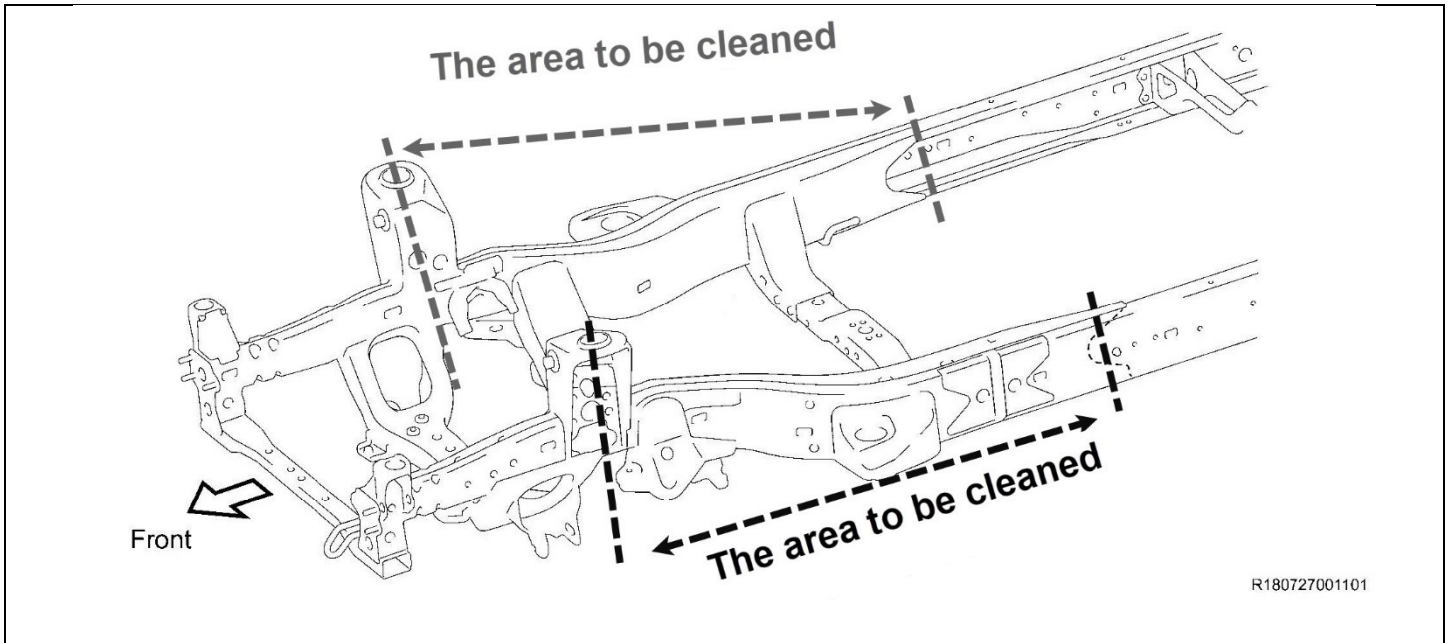

- b. Move the brush in and out of the frame in a quick motion, twisting the brush left and right to get the corners of the top of the frame

NOTE: The amount of time needed to use the brush will vary from frame to frame. The typical time will be 15 to 20 minutes per side however it may take longer depending on how dirty the frame is and the type of dirt/debris in the frame

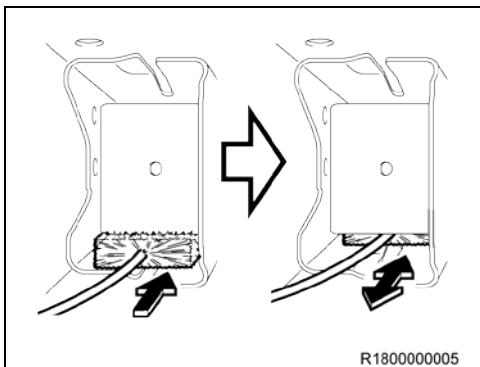

- c. Remove the brush from the top of the box section and insert it past the bottom of the box section
 - d. Move the brush in and out of the frame in a quick motion, twisting the brush left and right to get the corners of the bottom of the frame

NOTE: The amount of time needed to use the brush will vary from frame to frame. The typical time will be 15 to 20 minutes per side however it may take longer depending on how dirty the frame is and the type of dirt/debris in the frame

2. **USE EXTENDED WIRE BRUSH TO CLEAN THE LH FRAME RAIL BOXED SECTION**

- a. Follow steps 1.a – 1.d for cleaning on the left-hand side.



Be careful not to damage the brake lines when cleaning the LH frame

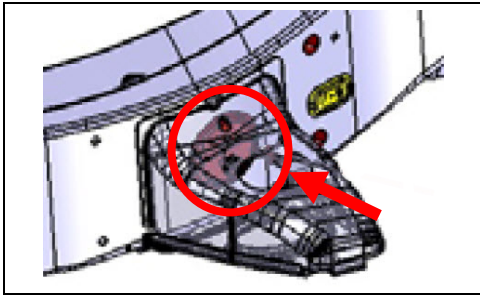

3. INSTALL CAB MOUNT FRAME PLUG

- Once all dirt and debris has been removed from the cab mount, install the cab mount frame plug to prevent dirt from the frame going into the cab mount.

Plug Part Number: 90950-A1008

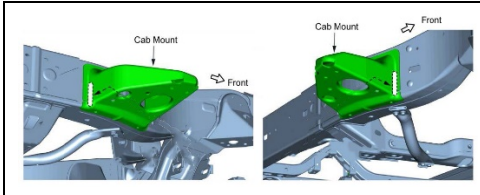

4. CLEAN INSIDE BOTH FRONT CAB MOUNTS

- If there is hardened dirt or other difficult to remove debris, use the rubber mallet to hit the outside of the cab mount to break up the debris
- Using the 2ft Air Gun, blow out all the dirt and debris inside the cab mount focusing on the inner corners.

5. CONFIRM CAB MOUNTS CLEANLINESS

- Using the endoscope provided to your dealer in the JOM campaign, confirm the inside of the cab mount is clean focusing on the inner corners

NOTE: The images below show the “minimum cleanliness” that the cab mounts can be. The frame can be cleaner than the images below but cannot be less clean.

If the cab mount is not clean enough, repeat steps 1-2 until clean

Inner Corner of the Cab Mount



6. CLEAN THE INNER OPEN SECTION OF THE FRAME (both LH and RH)

- Clean the welds and area highlighted in the illustrations below using the wire brush (Hand Tool) show in the illustrations below until no dirt, debris, or rust is present on the welds

NOTE: The cross member may not be present on short wheel base frames

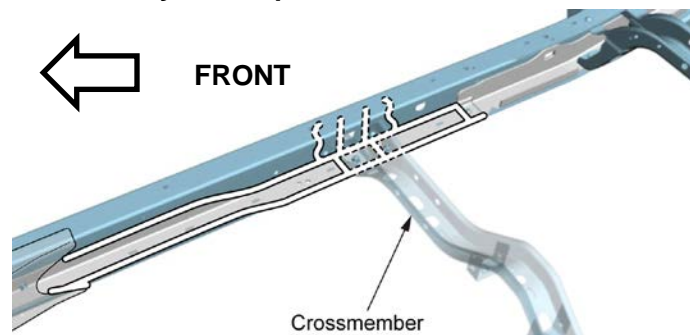

7. REMOVE DIRT AND DEBRIS FROM INSIDE THE FRAME

- a. Using the 2ft Air Gun, blow out all the dirt and debris working from the front of the vehicle to the back using the various plug holes. You may have to remove plugs from the frame to blow out all debris. Only remove the plugs in the sections being cleaned.

NOTE: It will normally take 4 to 5 passes with the air gun to remove the all the debris from the frame

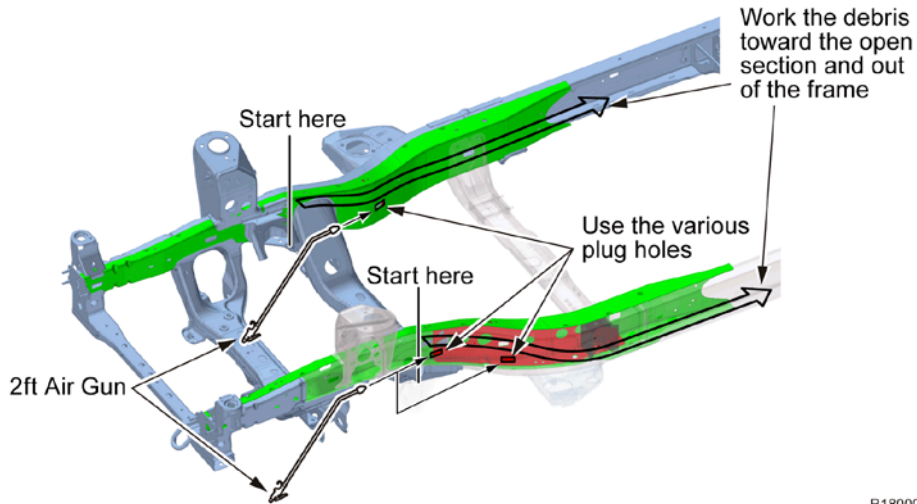

NOTE:

Confirm no rocks or other debris are stuck in the channel shown below on the LH and RH side of the frame



8. REMOVE DUST AND DEBRIS FROM OPEN SECTION (LH AND RH SIDE)

- a. Blow any dust, debris, that might be on the opens section shown below

NOTE: The cross member may not be present on short wheel base frames

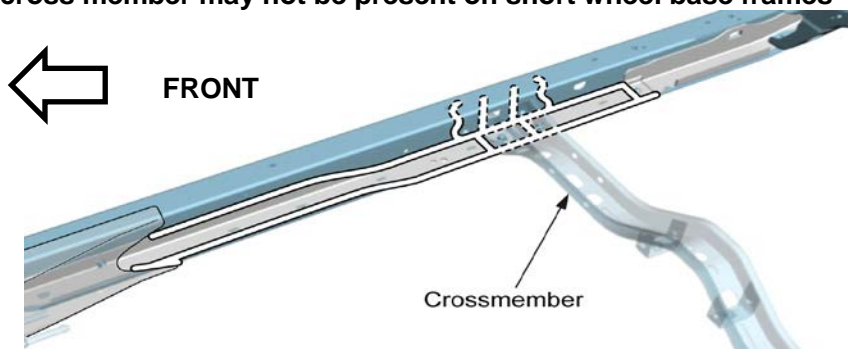

9. CONFIRM FRAME CLEANLINESS FOR LH AND RH SIDE

- a. Using the endoscope provided to your dealer in the JOM campaign, confirm the inside of the frame is clean by inserting the endoscope into various plug holes.

NOTE: The images below show the “minimum cleanliness” that the frame can be. The frame can be cleaner than the images below but cannot be less clean.

- b. If the frame is not clean enough repeat the cleaning procedure until clean enough



The frame must be cleaned before applying the wax. If the frame is not completely clean then the wax coating will not adhere to the frame properly



10. MOVE ANY LARGE ROCKS AND DEBRIS TO THE FRONT OF THE FRAME

NOTE: Some rocks and debris will not be able to be pushed past the box section of the frame. For those cases follow the following steps

- a. Using the 2ft Air Gun, blow all the dirt and debris to the front of the frame working from the rear of the vehicle to the front using the various plug holes.

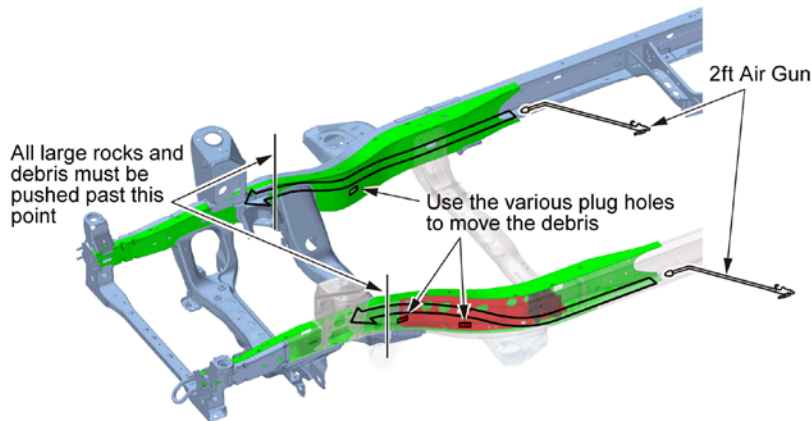

R1800000008

11. CHECK FOR LARGE ROCKS AND DEBRIS

- a. Using the JOM Endoscope, confirm all large rocks and debris have been removed. If not, repeat step 9 until the rocks are removed from the spray application area



If the wire brush has worn down to the point of not being effective or you have an issue with any other tool related to K0D contact *Bosch Technical Assistance Line - 1-800-933-8335 (Option 4)* for instructions on how to acquire replacement parts

XII. WAX APPLICATION WORK PROCEDURE

A. CIRCUIT OF THE APPLICATION UNIT

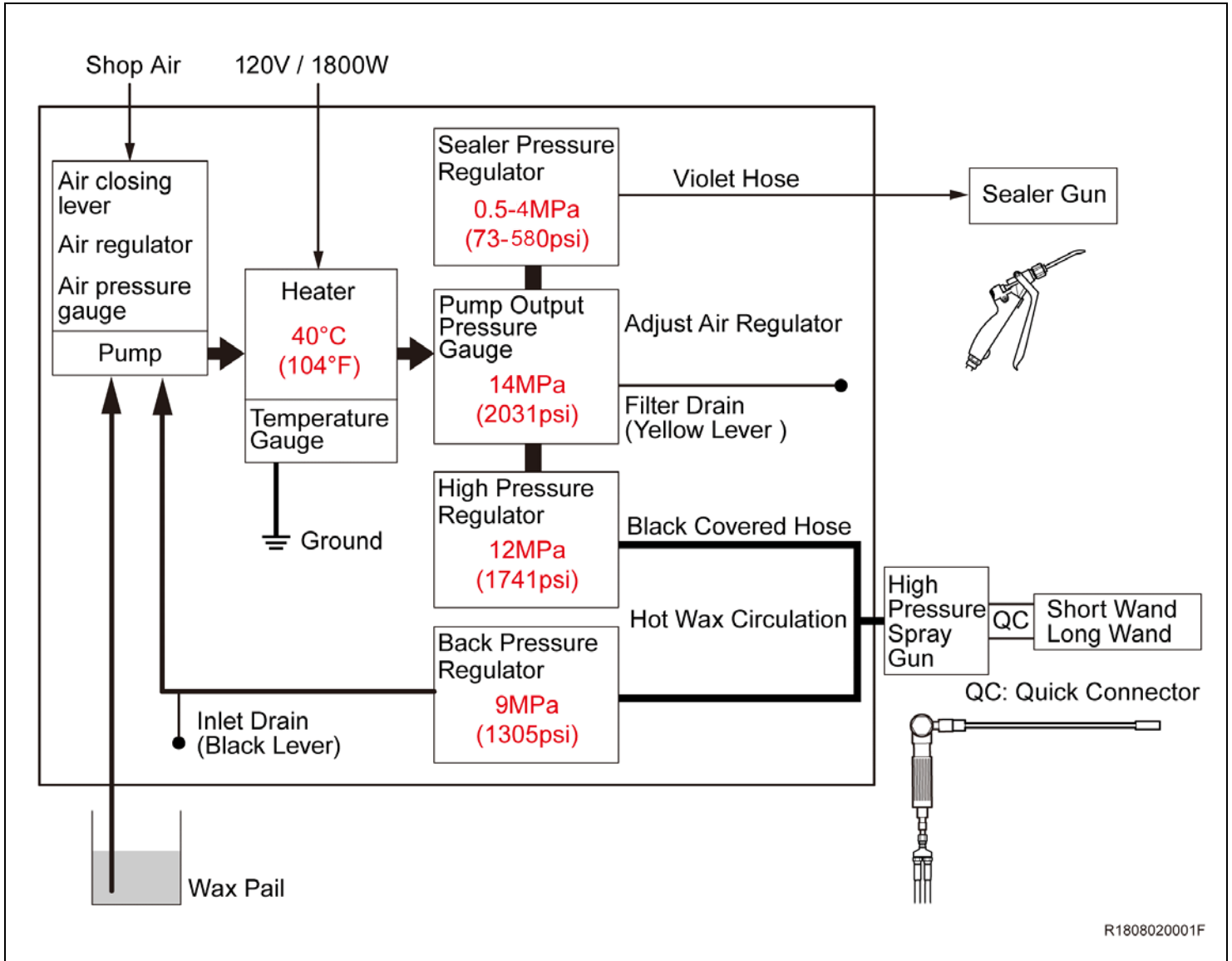

B. COMPONENTS OF THE APPLICATION UNIT

1. SYSTEM

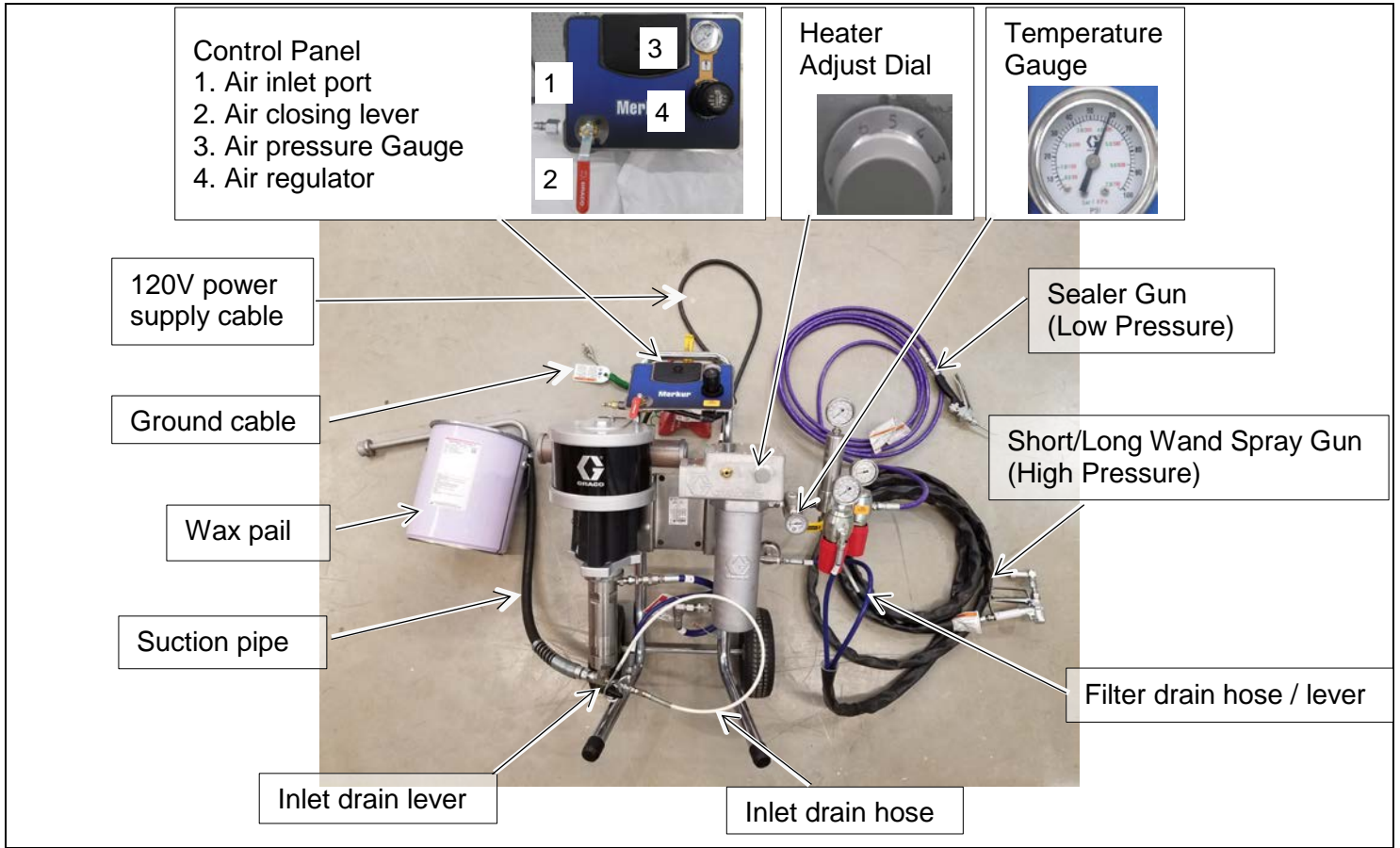

2. SETTINGS

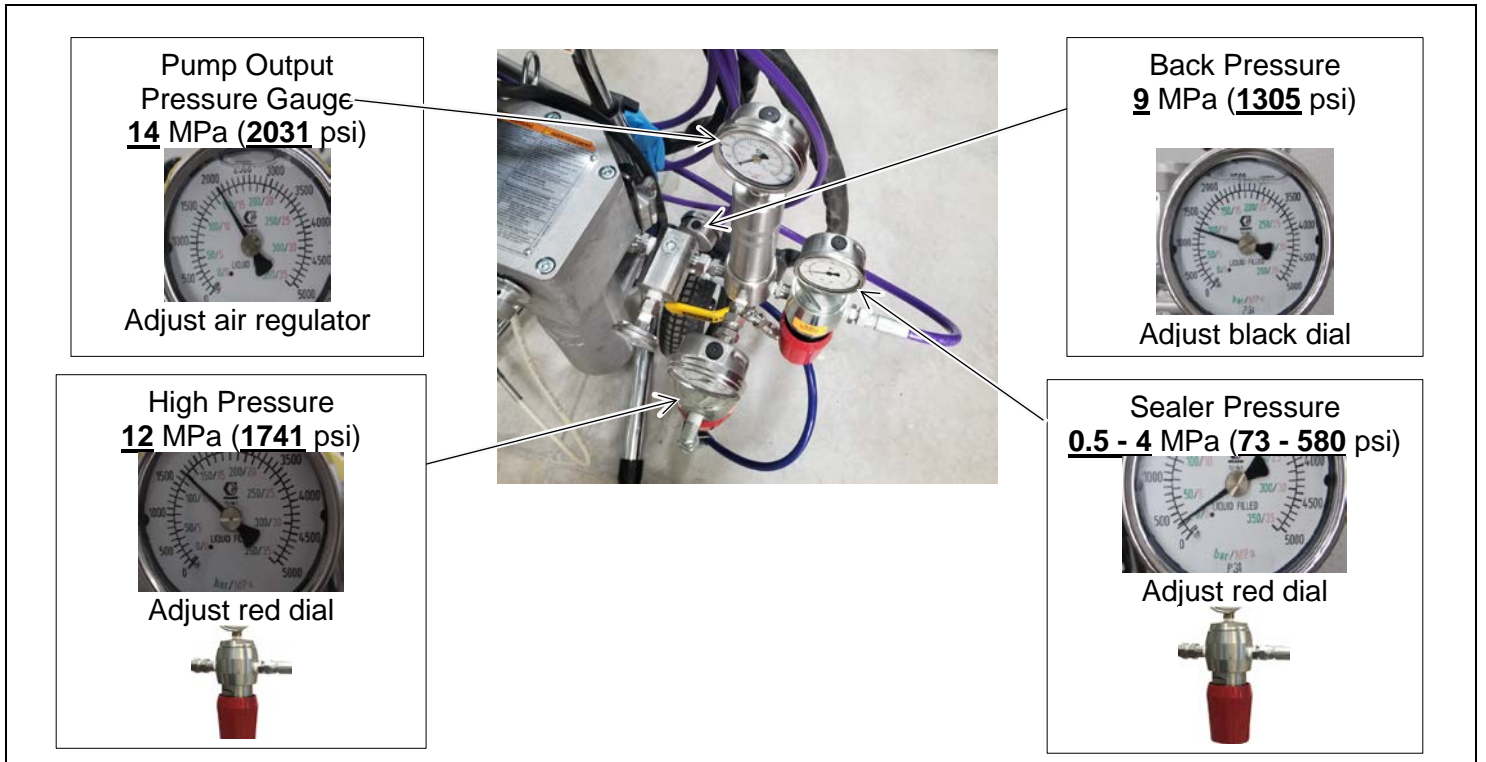

C. WAND SPECIFICATION

1. WAND

a) SHORT WAND

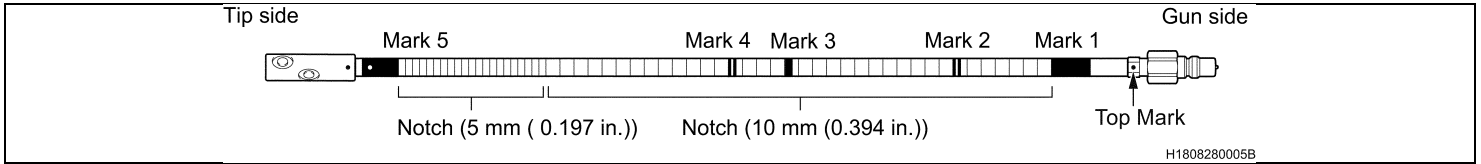

b) LONG WAND

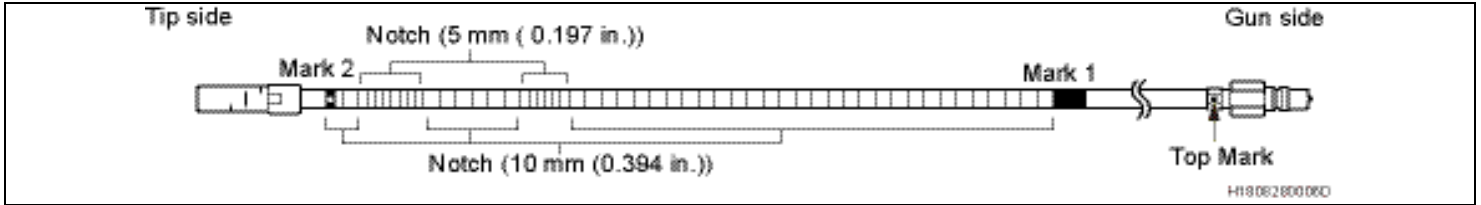

c) SEALER GUN

1. Simple tubular tip.
2. The amount of wax applied is judged visually.

2. WAND TIP

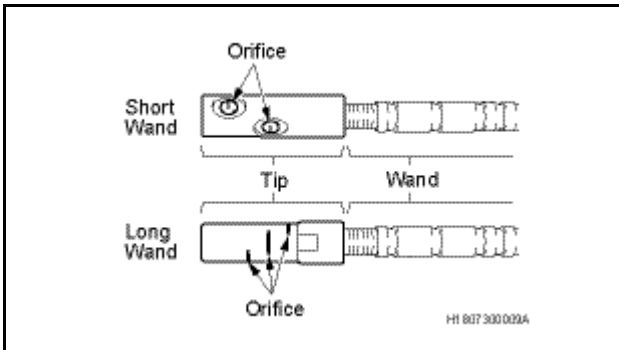

- a) The tip of the short wand has 5 orifices to spray out wax.
- b) The tip of the long wand has 6 orifices to spray out wax.

3. WAND TOP MARK

- a) The punch marks found on the wand tip side and gun side are the TOP marks. Confirm that the TOP mark is facing upward at all time.

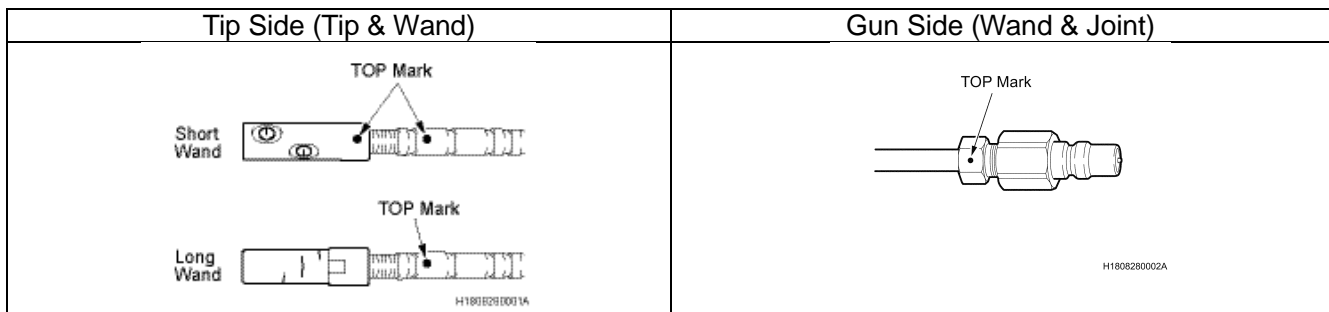

4. INSTALLATION OF THE WAND TO THE GUN (SHORT & LONG WAND)

- a) Connect the short or long wand to the gun by sliding in (Quick connector).
- b) Adjust the wand connecting portion to set the TOP mark upward.



DO NOT use red shop towels or other lint products when handling the wands as they will cause a clogged tip. Only use lint free towels when handling the wands

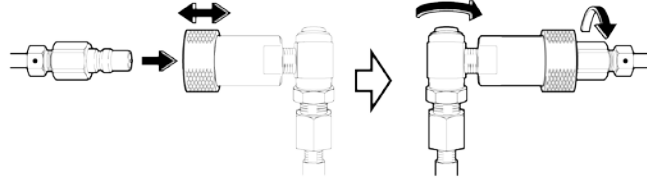

Direction for RH side

Direction for LH side

H180827003C

D. INITIAL SET UP

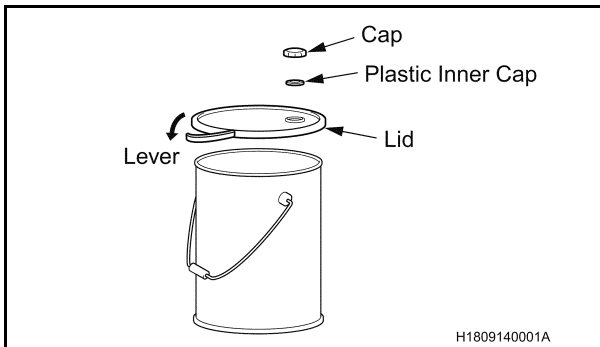

1. PREPARE THE WAX PAIL

- a) Press the center of the cap and remove.
- b) Remove the plastic inner cap.
- c) Open the lever and remove the lid.
- d) Remove the strainer from the suction pipe and insert the pipe into the cap hole of the lid.
- e) Reinstall the strainer to the pipe and then reinstall the wax lid to the can.

STOP Be careful to **NOT** let the pipe, strainer and lid contact foreign materials when working and **DO NOT** allow any foreign materials enter the wax pail.

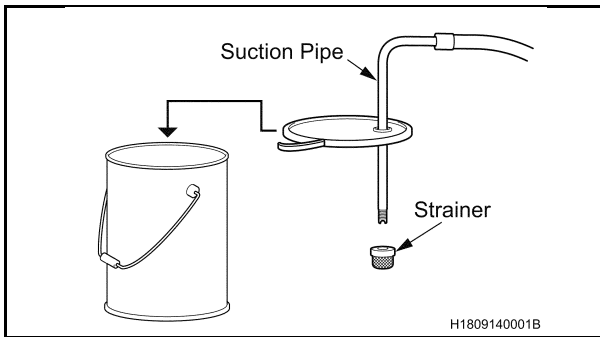

2. ADD THROAT SEALING LIQUID

- a) A bottle of Throat Sealing Liquid (TSL) can be found on attached near the wheel of the pump assembly. This bottle will be used as part of maintenance of the pump. Store the bottle in an accessible area.
- b) Before pump operation fill the white colored TSL dish half-way with TSL fluid.

STOP Contact Bosch Technical Assistance line to order additional TSL fluid.
Bosch Technical Assistance Line - 1-800-933-8335 (Option 4)

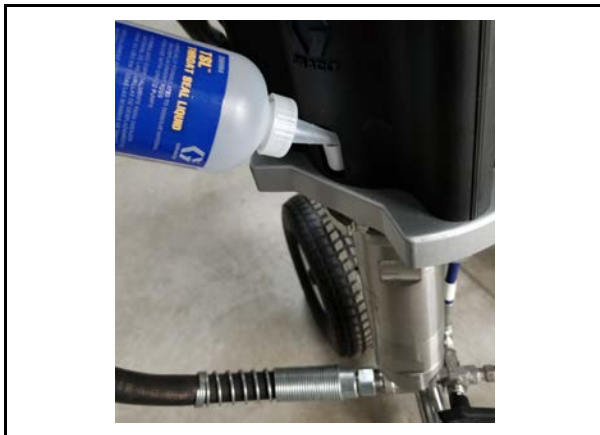

3. CHECK THROAT SEALING LIQUID LEVEL

- a) Remove the TSL cover screw and remove the cover
- b) Confirm the TSL dish is filled half way with TSL fluid

STOP You will need to check the TSL level every day, or if the pump has been moved before pump operation.



4. SYSTEM SET UP

- a) Lock the triggers of the high pressure spray gun and sealer gun.
- b) Connect the short wand to the high pressure gun

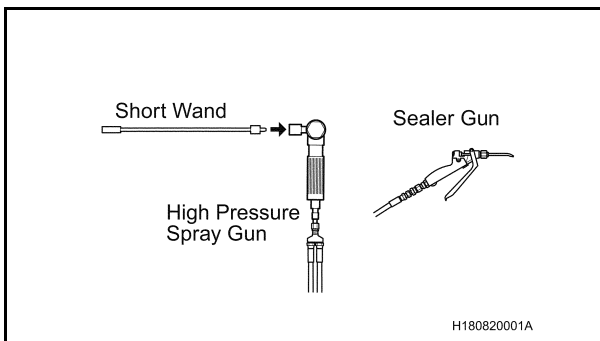

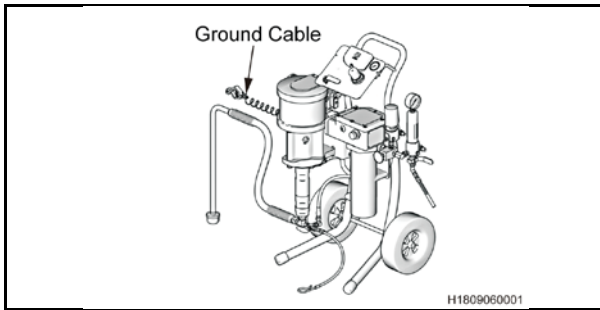

c) Connect the ground cable.

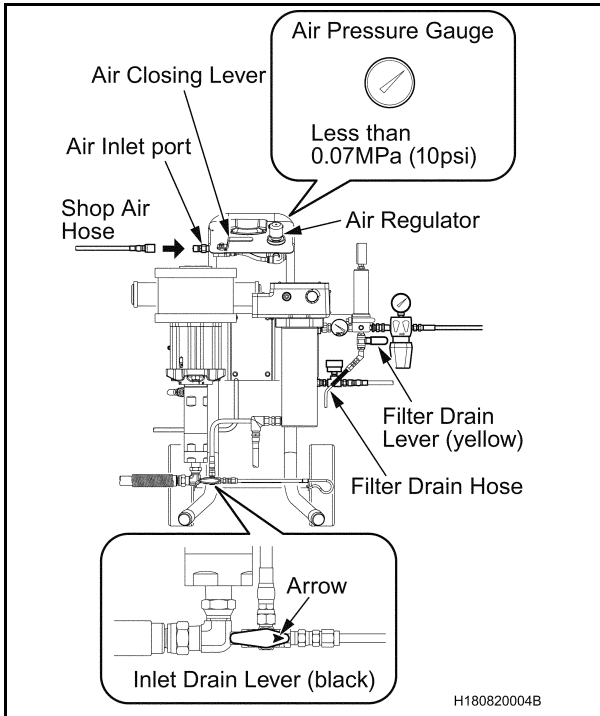

- d) Connect the shop air hose to the air inlet port.
- e) Open the air closing lever.
- f) Open the filter drain lever (yellow).
- g) Turn the air regulator to adjust the air pressure to less than 0.07 MPa (10 psi) on the air pressure gauge.
- h) Place a container under the filter drain hose and wait until white wax continuously comes out.
- i) Close the filter drain lever (yellow) once all the air is removed.
- j) Turn the inlet drain lever (black) to drain side (arrow to inlet drain hose side) and place a container under the filter drain hose and wait until white wax continuously comes out.
- k) Close the inlet drain lever (black) once all air is removed by turning the arrow back towards the inlet feed line.

- l) Confirm the heater adjust dial is set to off
- m) Connect the 120V power supply cable.

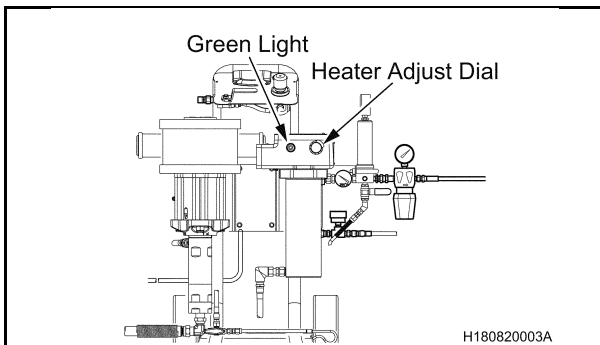
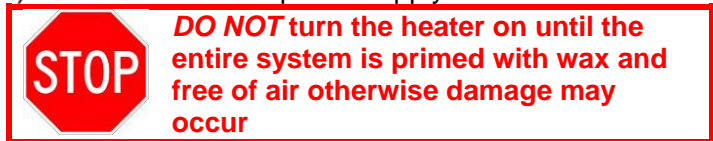

- n) Adjust the heater adjust dial to 6 to warm up the wax. Confirm the green light turns on when heater adjust dial first adjusted.

Note: It can take 30 minutes or more to bring the wax up to temperature depending on room temperature. Continue with the process while the wax heats up.

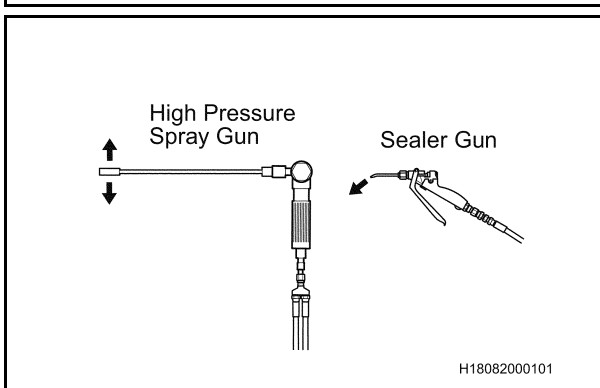
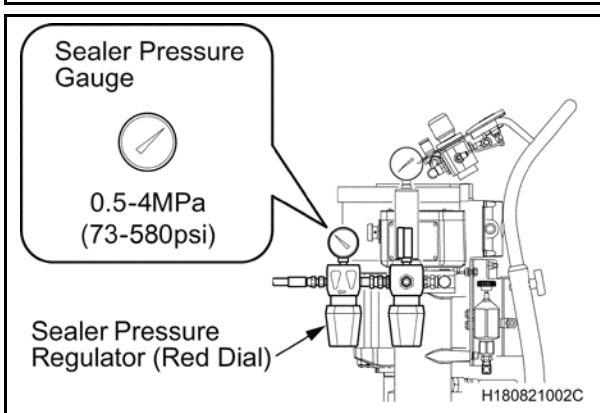
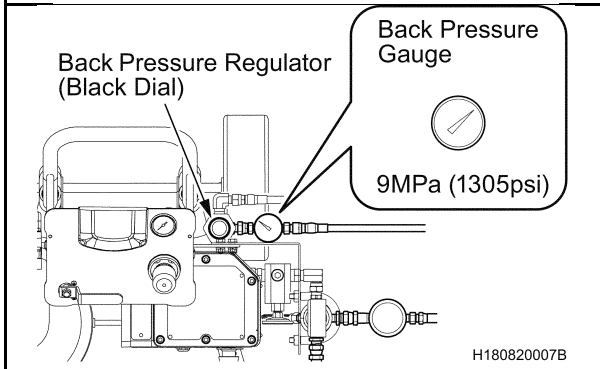
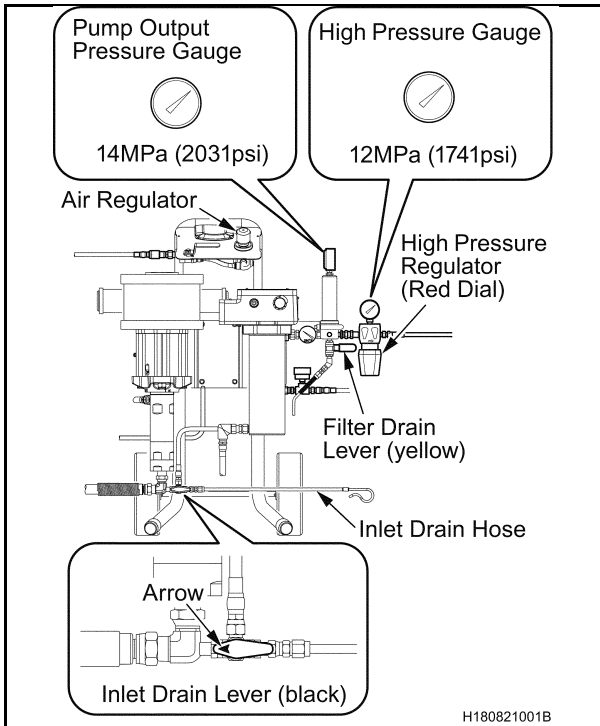

- o) Turn the air regulator to adjust the pump output pressure to 14 MPa (2031 psi).

STOP NEVER set the pressure to be over 14 MPa (2031 psi).

- p) Turn the high pressure regulator (red dial) to adjust the high pressure to 12 MPa (1741 psi).

STOP NEVER set the pressure to be over 12 MPa (1741 psi).

- q) Confirm the inlet drain lever (black) is pointing towards the inlet feed hose.

- r) Turn the back pressure regulator (black dial) to adjust the back pressure to 9 MPa (1305 psi).

- s) Turn the sealer pressure regulator (red dial) to adjust the sealer pressure to 0.5 - 4 MPa (73 - 580 psi).

NOTE:

Adjust the pressure within the range to make it easy to work with when applying wax.

STOP NEVER set the pressure to be over 4 MPa (580 psi).

- t) Operate the sealer gun to drain wax.

Reference Value: 100 ml

- u) Operate the high pressure spray gun to drain wax.

Reference Value: 100 ml

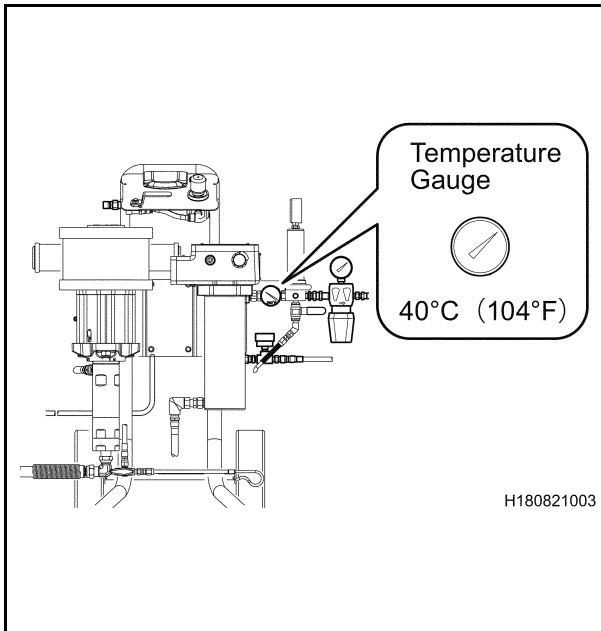

5. SET UP CONFIRMATION

- a) Confirm that the wax temperature is 40 °C (104 °F) on temperature gauge.

NOTE:

If the wax temperature is not heated enough, please wait for a couple of minutes. It may be necessary to turn the dial to a higher level depending on air temperature in the shop.

DO NOT warm up the wax temperature higher than 50 °C (122 °F).

If the wax has been overheated the system will need to be flushed with new wax prior to application



If the system needs to be drained due to overheating the wax you must drain 2L of wax from the inlet drain lever (black)

- b) Confirm pump cycle rate.

Standard Value: 7 – 10 times/min

NOTE:

If the pump cycle rate is faster or slower than the standard value, turn the back pressure regulator to adjust the rate within the range.

- c) Confirm that the pump output pressure is 14 MPa (2031 psi). If not, adjust the air regulator to meet 14 MPa (2031 psi).



NEVER set the pressure to be over 14 MPa (2031 psi).

- d) Confirm that the high pressure is 12 MPa (1741 psi). If not, adjust the high pressure regulator (red dial) to meet 12 MPa (1741 psi).



NEVER set the pressure to be over 12 MPa (1741 psi).

- e) Confirm that the sealer pressure is 0.5 - 4 MPa (73 - 580 psi).



NEVER set the pressure to be over 4 MPa (580 psi).

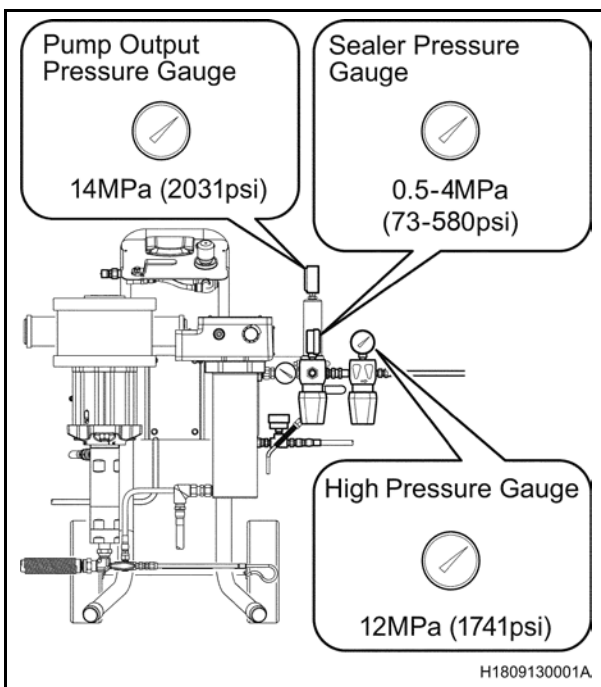

- f) Check each line for wax leakage.



***If there is any wax leakage, stop using the system immediately and contact the following number for assistance:
Bosch Technical Assistance Line - 1-800-933-8335 (Option 4)***

E. SETTINGS AFTER WORK

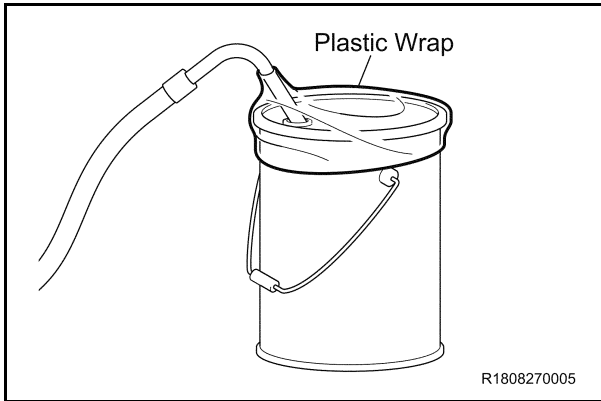

1. SETTINGS AFTER WORK

- g) Close the air closing lever.
- h) Turn the heater adjust dial off.
- i) Disconnect the shop air hose.
- j) Disconnect the 120V power supply cable and ground cable.
- k) Cover the guns and wands with plastic wrap to protect them from dust.
- l) Close the lid of the wax pail securely and wrap the cover of the pail with plastic wrap. Store the wax pail indoors avoiding any heat source.

NOTE:

The wax can be used for 2 months once opened. After that it must be replaced with new wax.

F. REMOVAL PARTS

Reference the appropriate repair manual on TIS for parts removal procedures.

2011MY
IF EQUIPPED:

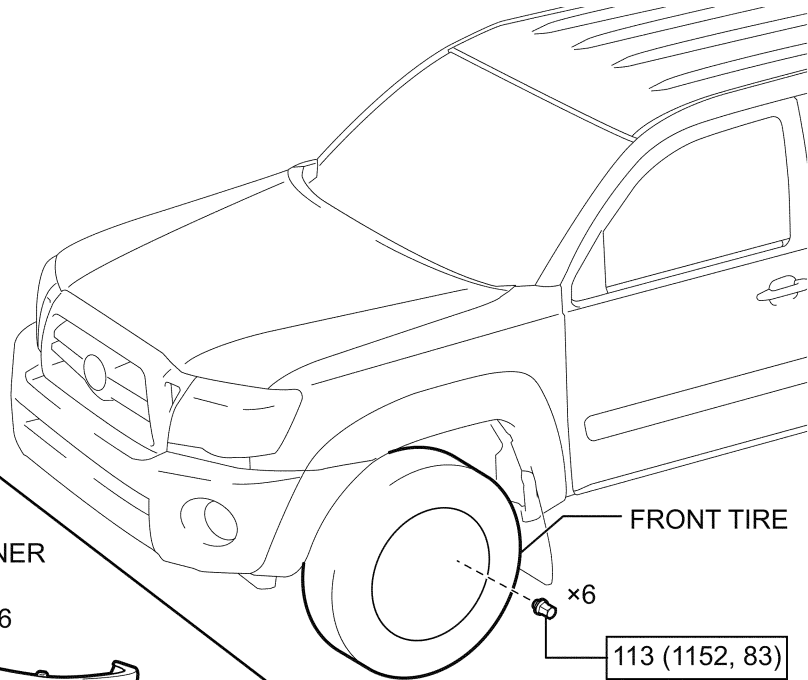
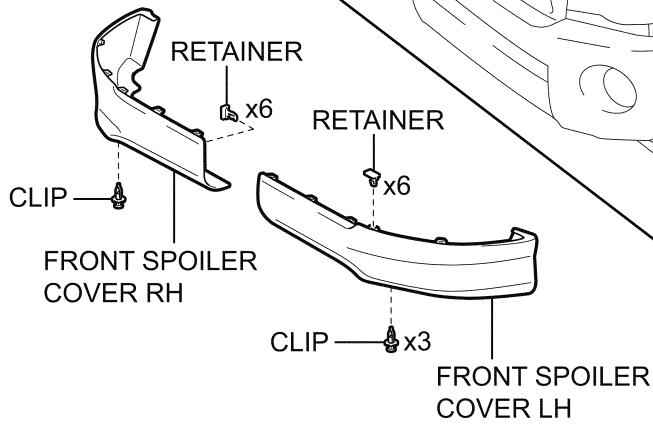

IF EQUIPPED:

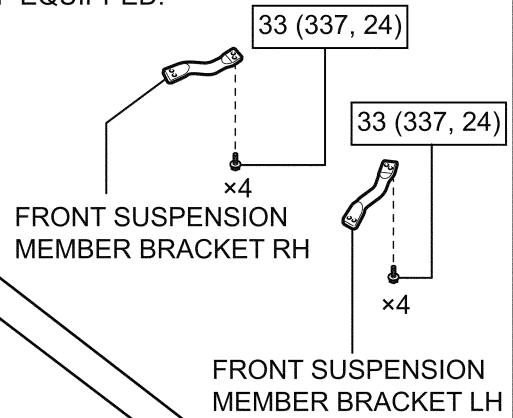

2012MY
IF EQUIPPED:

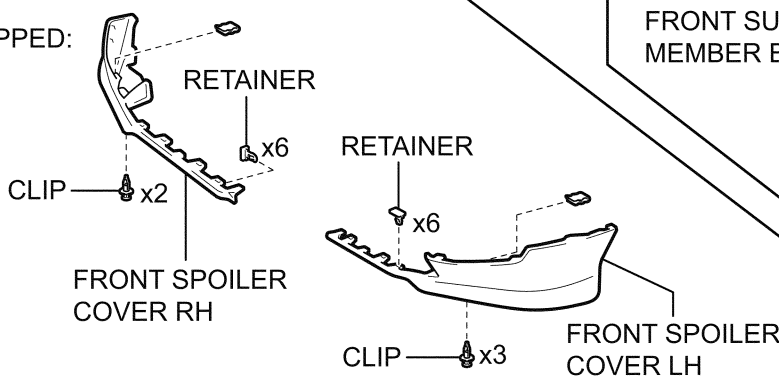

2016-2017 MY
IF EQUIPPED:



[N*m (kgf*cm, ft.*lbf)] : Specified torque

R1807270005A

G. MASKING AROUND WORK STALL

NOTE:

Depending on the shop layout, it may be necessary to put barriers to prevent accidental over spray
Masking on the floor is unnecessary. (if wax falls from the frame, clean the spill right away to avoid a fall hazard)

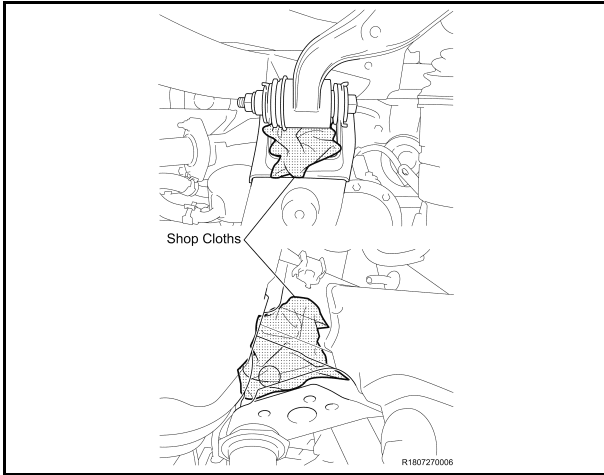

1. VEHICLE MASKING

NOTE:

In this work, masking needs to be done only partially as the drips and scattering are few.

- a) Using an infrared thermometer ensure the exhaust has cooled.
- b) Cover the holes from which wax can spill out using shop cloths or the likes.
- c) Protect each brake tube as the wand may hit them. **(LH Side Only)**

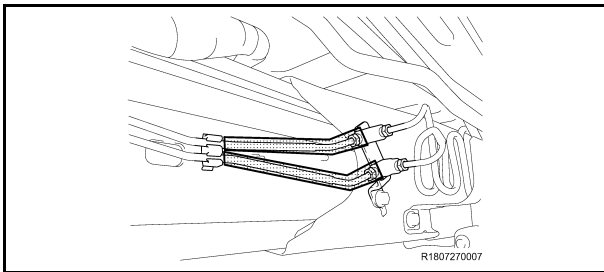

H. APPLY WAX WITH SHORT WAND



Before starting this process, review the SCK0D E-Learning Spray Application section for key details

1. PREPARE FOR WAX APPLICATION

- a) CHECK THE REMAINING WAX AMOUNT
1. Check that more than 1/3 of wax is in the wax pail. If not, add **NEW** wax to fill up the can.



The wax level must **NOT** be less than 1/4 as the pump starts suctioning air.

NOTE :

1 wax pail (18 Liters) is for 3 to 4 vehicles.

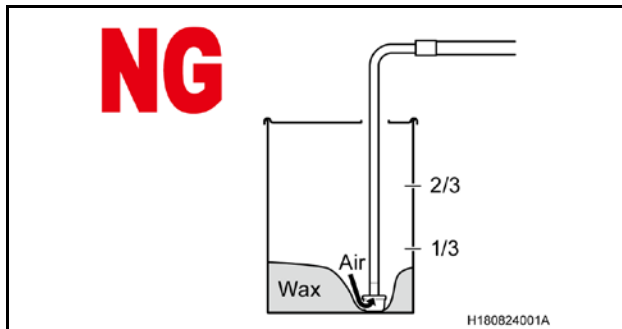

- b) CHECK PUMP CYCLE RATE
- Standard Value: 7 - 10 times/mins**

NOTE:

If the pump cycle rate is faster or slower than the standard value, turn the back pressure regulator to adjust the rate within the range.

- c) CHECK EACH PRESSURE
- Standard Value:**

- Pump output pressure: 14MPa (2031 psi)
- High pressure: 12 MPa (1741 psi)
- Sealer pressure: 0.5 - 4 MPa (73 - 580 psi)



NEVER set the pressures to be over the specified values.

- d) CHECK WAX TEMPERATURE
- Standard Value: 40 °C (104 °F)**



DO NOT warm up the wax temperature higher than 50 °C (122 °F)

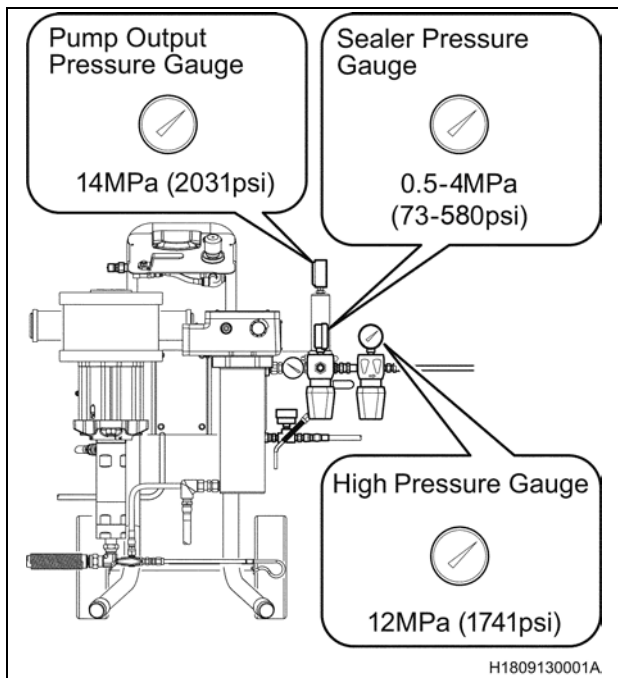

e) CHECK SPRAY PATTERN

1. Connect the short wand to the high pressure spray gun.
2. Weigh the empty cup and zero the scale
3. Spray 1 shot of wax on Paint Prep cup (Φ 10 - 15 cm (3.94 - 5.91 in.) for paint work).
4. Visually inspect the wax discharged from 5 orifices is continuously connected.
(Refer to XII. C. WAND SPECIFICATION)

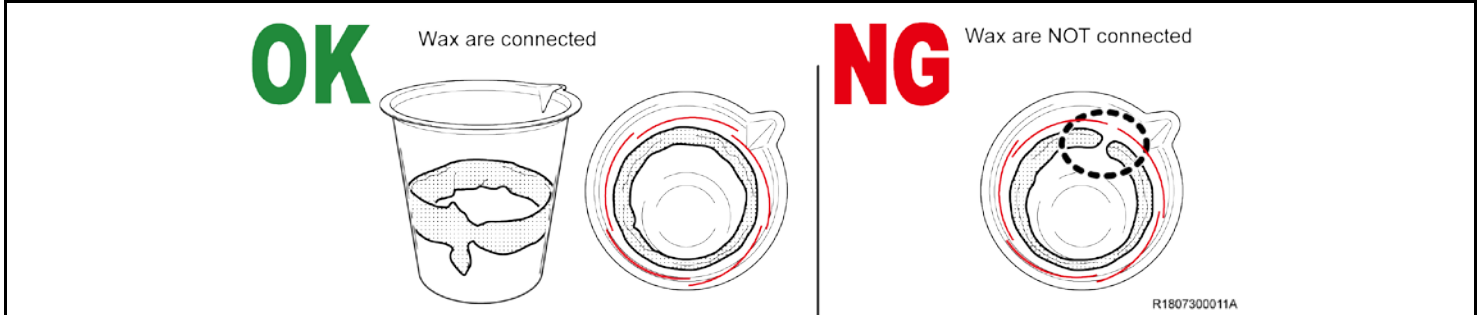

f) CHECK WAX DISCHARGE AMOUNT

1. Measure the weight of the empty Paint Prep cup.
2. Spray 10 shots of wax into Paint Prep cup and measure the entire weight.

NOTE:

- Fully pull the spray gun trigger to stabilize the discharge amount of wax per shot.
- You may need to practice to be able to spray 10 g (0.353 oz.) of wax per shot.
- **DO NOT** spray 10 shots continuously as the pressure lowers.

3. Subtract the weight of Paint Prep cup and calculate the weight of 1 shot.

Standard Value: 100 – 120 g (3.53 - 4.23 oz.) [10 - 12 g (0.353 - 0.423 oz.) per shot]

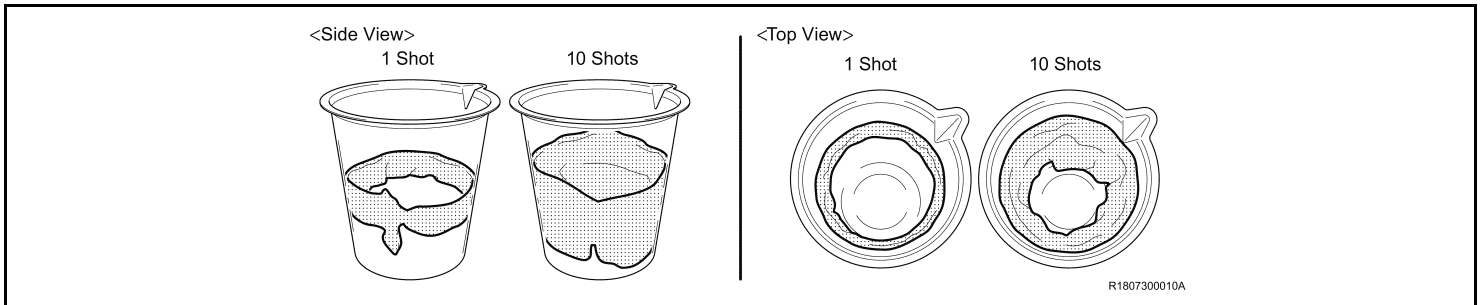

- When replacing the high pressure wands (short or long), make sure to perform the checks shown above every time.
- If the gun trigger is pulled when the pump is operating, wax cannot be applied properly. In such a case, redo the procedure to check properly.
- **DO NOT DISCARD INITIAL SPRAY CHECK CUP.** You will need to upload an image of the spray cup at a later step

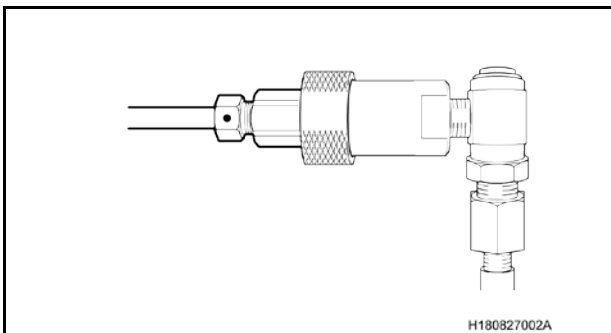

g) CHECK WAND TOP MARKS

1. Confirm that the TOP marks on the wand are on the upper side when using the high pressure spray gun with short or long wand.
(Refer to XII. C. WAND SPECIFICATION)

2. INSERT FROM THE INNER APPLICATION HOLE TOWARDS FRONT

* The illustrations show RH side only. Use the same procedure for LH side.

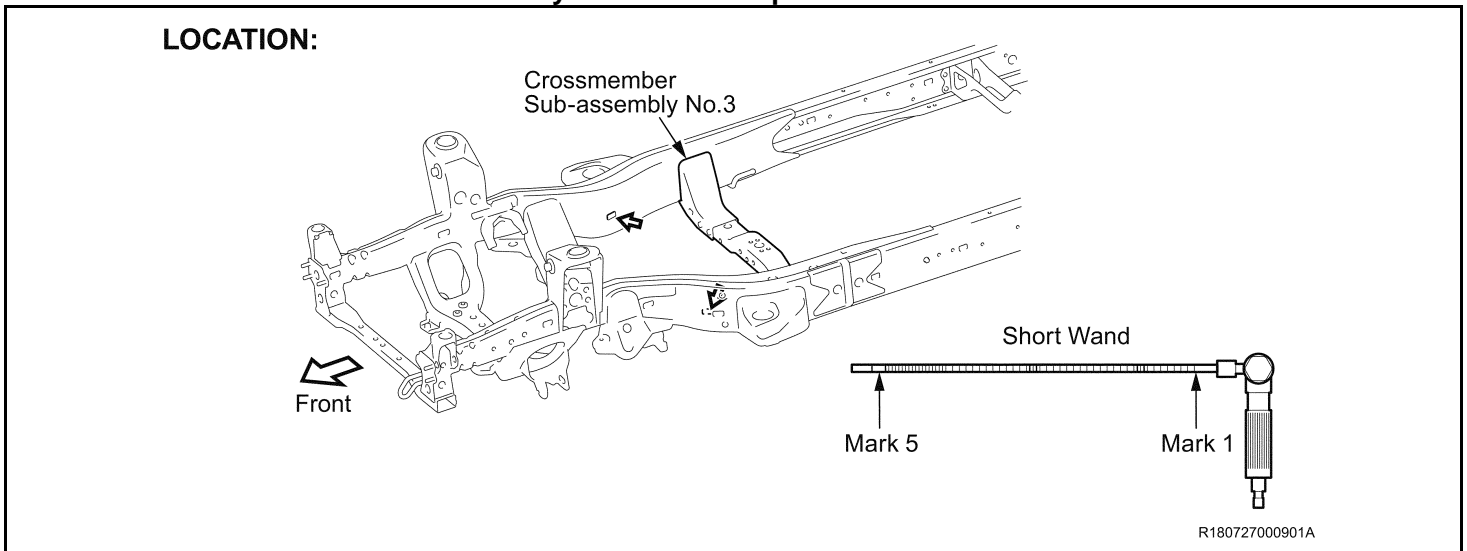

If the gun trigger is pulled when the pump is operating, wax cannot be applied properly. In such a case, spray wax again at the same place.

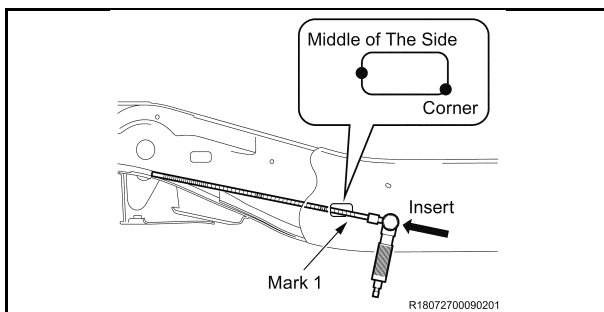

- Insert the short wand forward up to mark 1 so that the wand touches the middle of the side of the application hole.
- Spray 1 shot to apply wax.

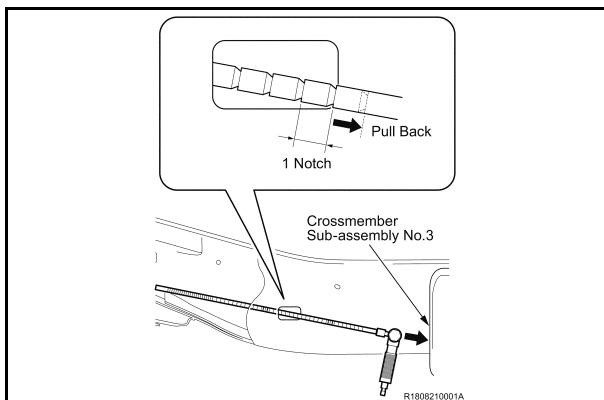

- Pull back the wand 1 notch and spray 1 shot.
- Repeat step c) until the gun hits the frame crossmember sub-assembly No.3.

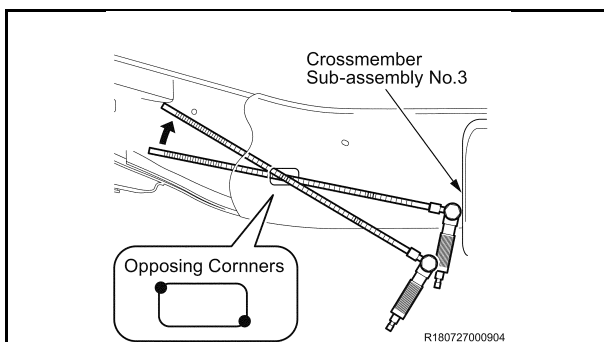

- Change the wand angle upward at the position where the gun hit the frame crossmember sub-assembly No.3.

NOTE:

- Place the wand so that it touches the opposing corners of the application hole.
- Be cautious as the spraying interval will change because the notch will be at every 5 mm (0.197 in.) at the last part of the wand.

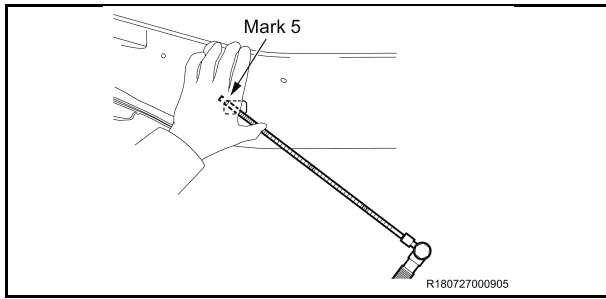

- f) Spray 1 shot and repeat step c) until Mark 5 appears.
- g) When spraying the last few shots, cover the application hole with your hand so that wax does not splash out.
- h) Apply masking tape on the application hole.

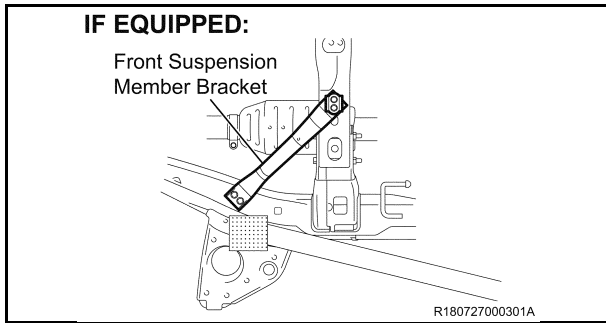

3. REINSTALL THE FRONT SUSPENSION MEMBER BRACKET (IF EQUIPPED)

- a) Reinstall the front suspension member bracket.
- Torque: 33 N*m (337 kgf*cm, 24 ft.*lbf)**



Be sure to install at this step.

4. INSERT FROM THE INNER OPENING TOWARDS FRONT

* The illustrations show RH side only. Perform the same procedure for LH side.

LOCATION:

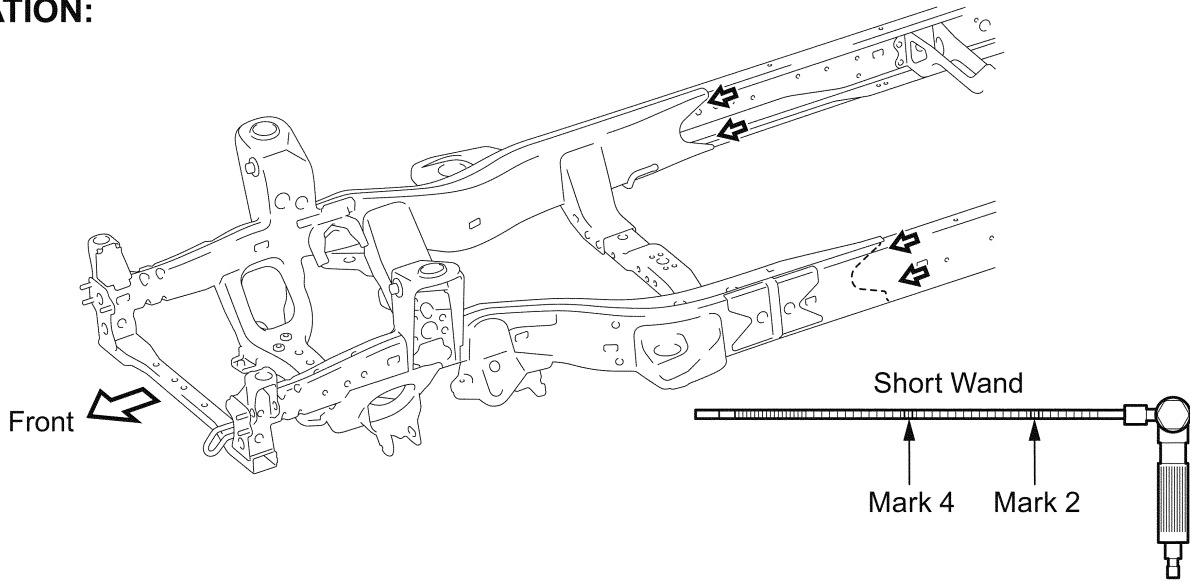

R180727001201001A



If the gun trigger is pulled when the pump is operating, wax cannot be applied properly. In such a case, spray wax again at the same place.

- a) Insert the short wand into the gap above the bulkhead forward, up to Mark 2.

NOTE:

The wand should be placed at the center of the gap.

- b) Spray 2 shots.

<Cross Section View>

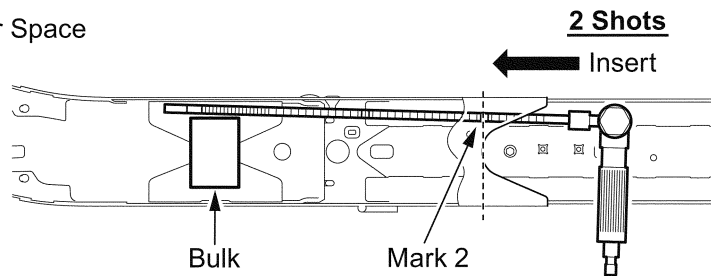
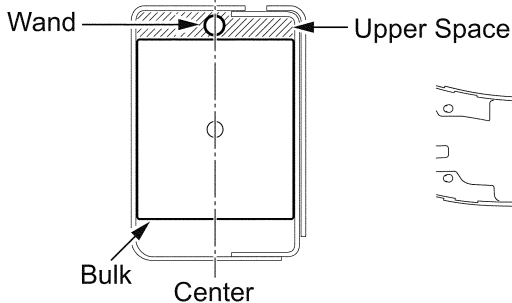

R180727001201002B

- c) Pull back the wand 10 mm (0.394 in.) and spray 2 shots.

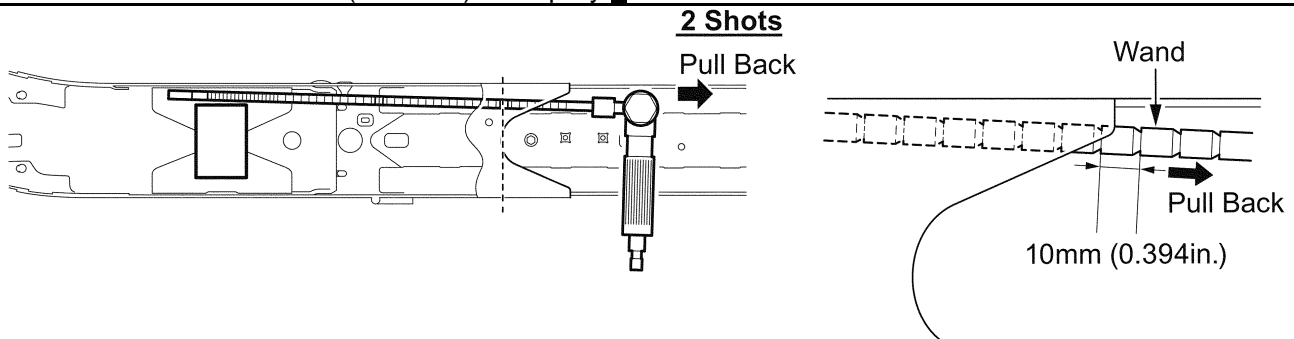

R180727001201003B

d) Repeat step c) until Mark 4 comes to the reference line.

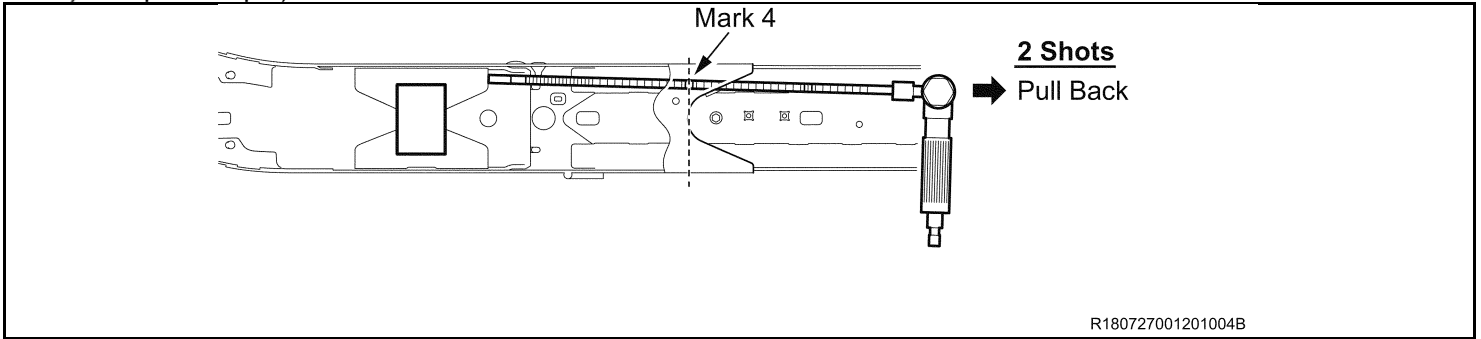

e) Insert the short wand into the gap below the bulkhead forward, up to Mark 2.

NOTE:

The wand should be placed at the center of the gap.

f) Spray **2** shots.

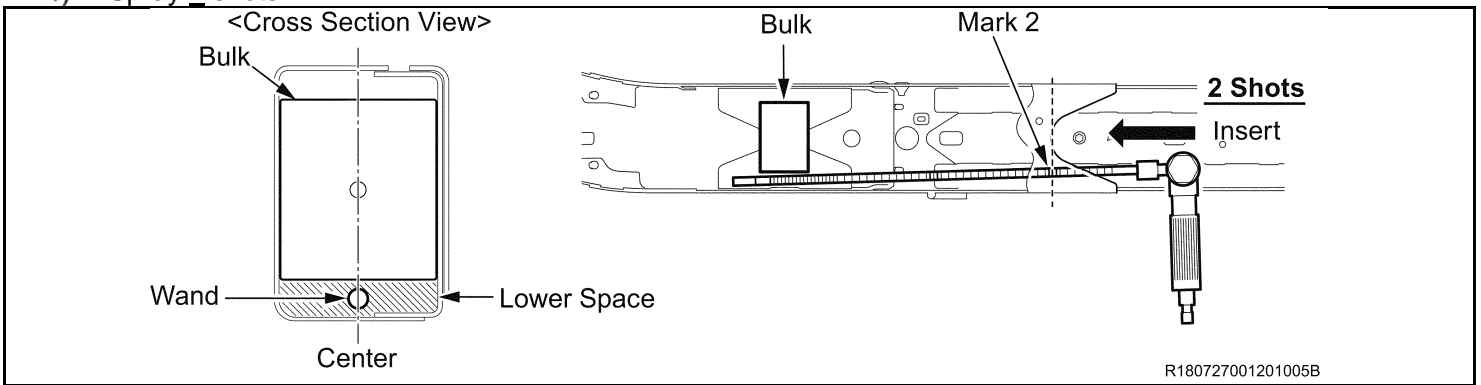

g) Pull back the wand 10 mm (0.394 in.) and spray **2** shots.

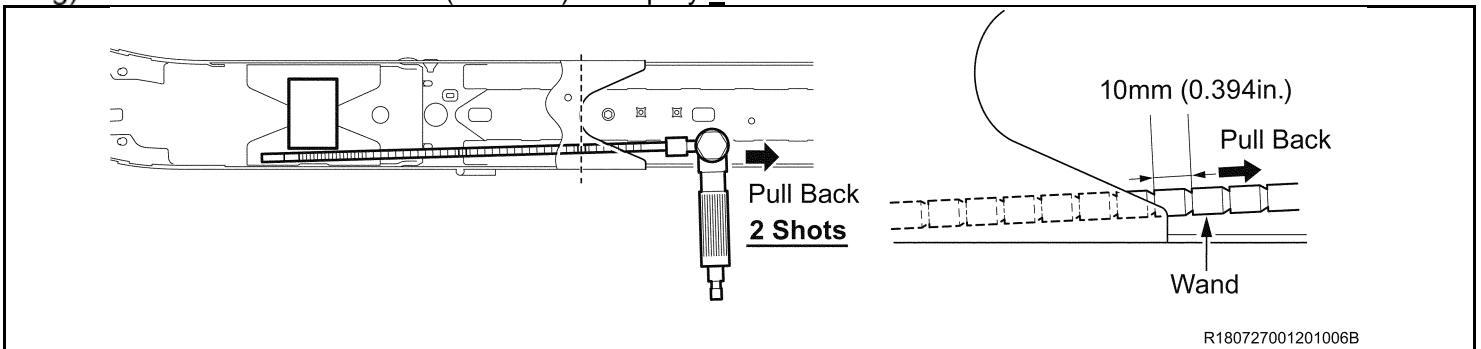

h) Repeat step g) until Mark 4 comes to the reference line.

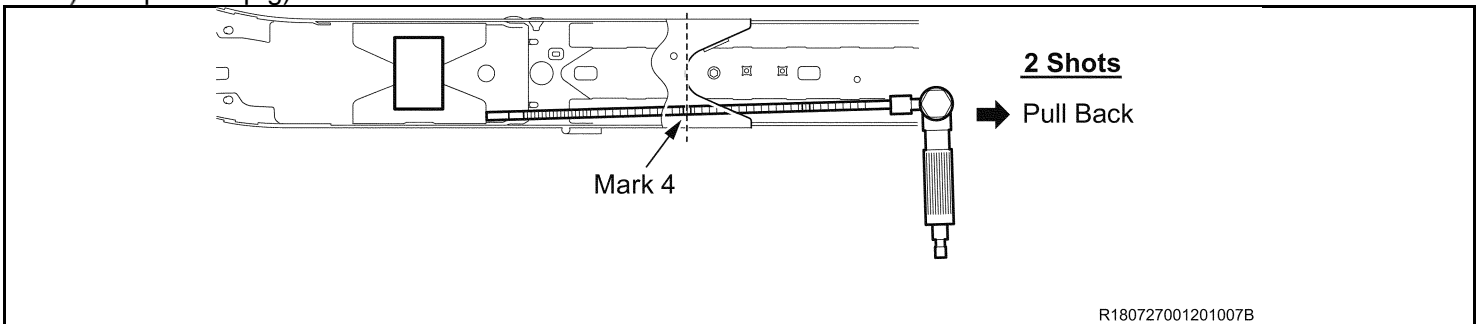

LOCATION:

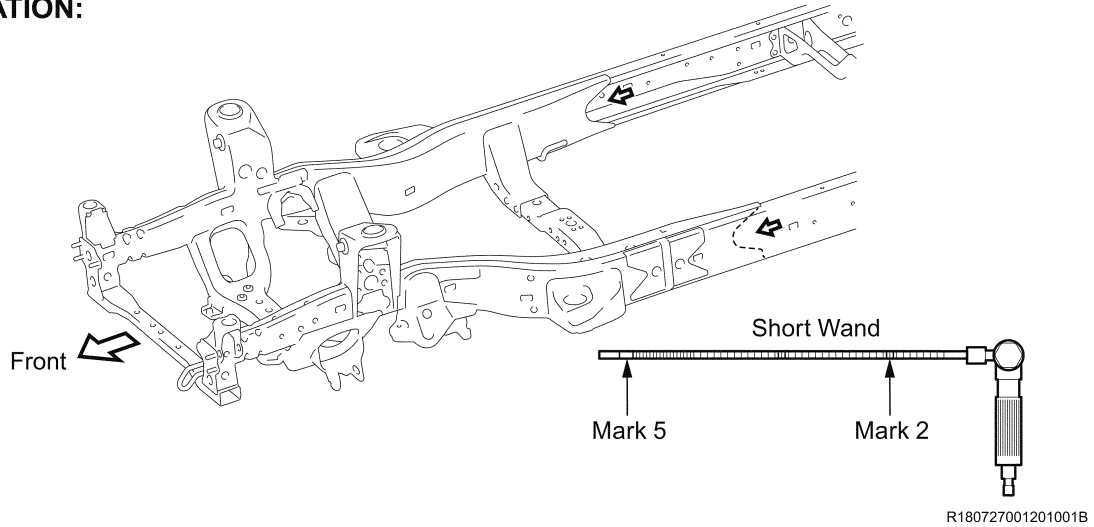

- i) Insert the short wand into the center hole of the bulkhead forward, up to Mark 2.
- j) Spray 1 shot.

<Cross Section View>

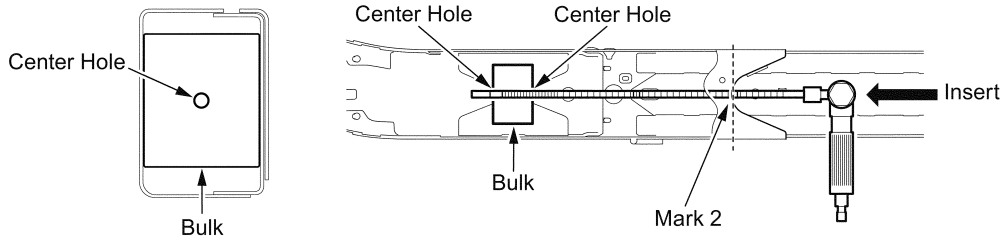

- k) Pull back the wand 10 mm (0.394 in.) and spray 1 shot.
- l) Repeat step k) until the wand comes out of the bulkhead center hole.

NOTE:

DO NOT spray wax at each 5 mm (0.197 in.) notch. Spray every 10 mm (0.394 in.) though the notches are at both 10 mm (0.394 in.) and 5 mm (0.197 in.) intervals.

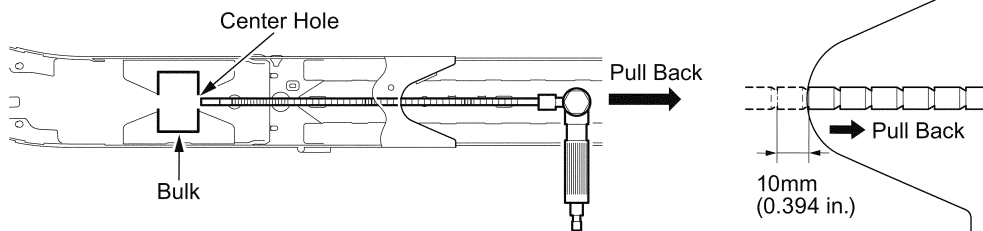

- m) Once the wand comes out of the bulkhead center hole, place the wand as close to the center as possible and keep spraying 1 shot at every 10 mm (0.394 in.) until Mark 5 appears.

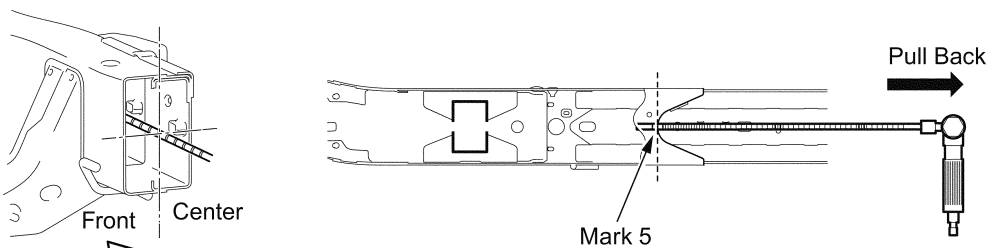

5. FROM THE BOTTOM SQUARE HOLE TO THE TOP

* The illustrations show RH side only. Perform the same procedure for LH side.

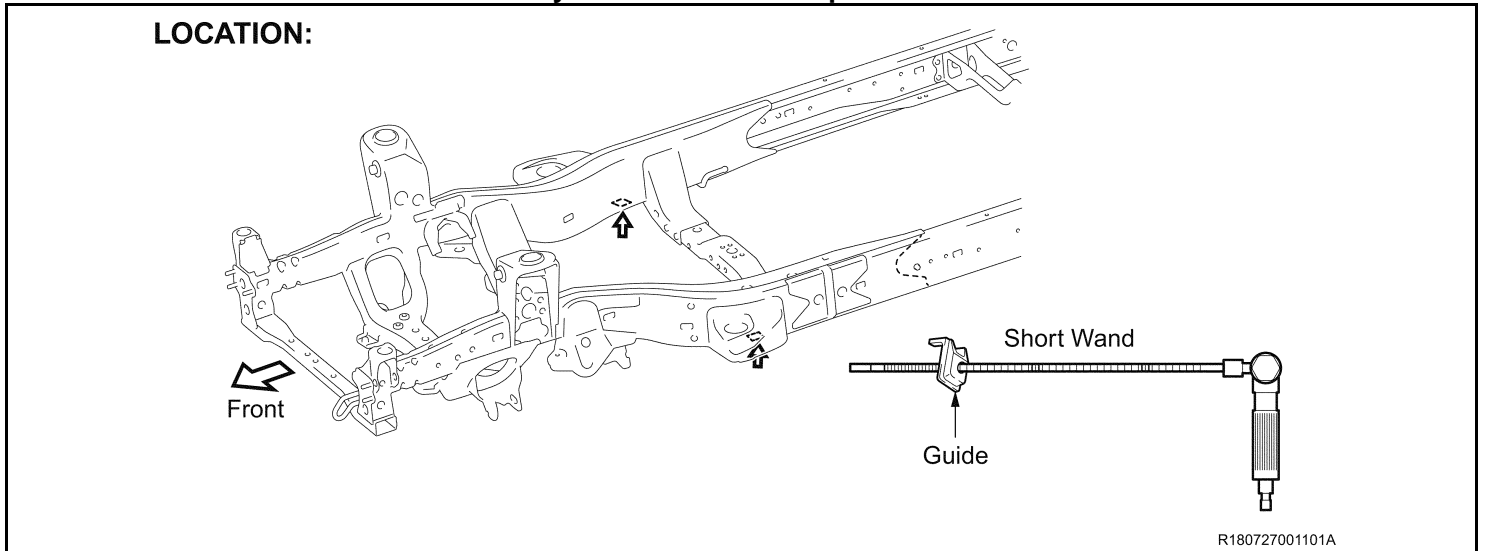

If the gun trigger is pulled when the pump is operating, wax cannot be applied properly. In such a case, spray wax again at the same place.

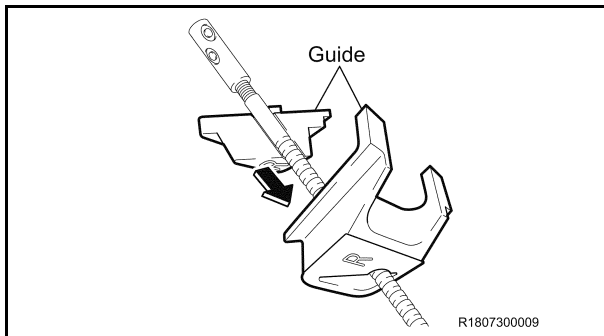

- Remove the masking tape applied to the application hole.
- Set the guide on the wand according to the mark. (The guide is supplied for LH and RH respectively.)

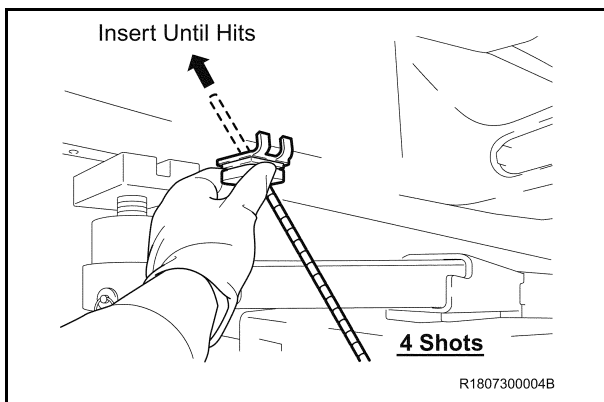

- Insert the wand until it hits the frame inner top.
- Spray 4 shots to apply wax.
NOTE:
Spray 4 shots at one spot.
- Apply masking tape to the application hole

6. REPEAT THE PROCEDURE ON THE OTHER SIDE

- Repeat from the step 2 to 7 on the other side of the frame side rail.

I. APPLY WAX WITH LONG WAND

* The illustrations show RH side only. Perform the same procedure for LH side.

Confirmation
Before wax application
(Refer to XII. H. 1. PREPARE FOR WAX APPLICATION)

- Wax temperature
- Spray pattern
- Wax Discharge Amount
- TOP mark positions

LOCATION:

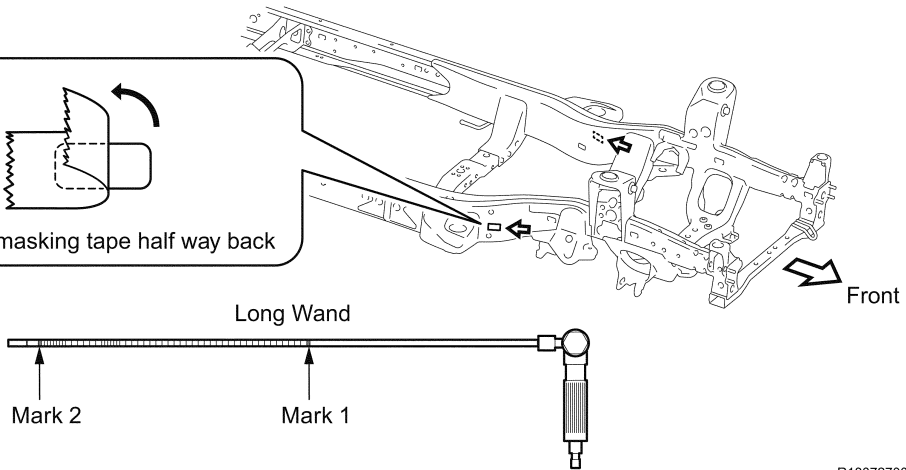
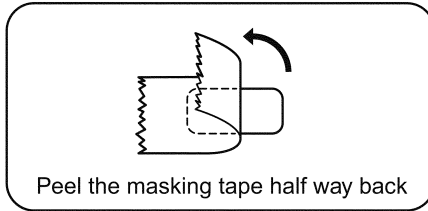

R180727001102B



If the gun trigger is pulled when the pump is operating, wax cannot be applied properly. In such a case, spray wax again at the same place.

1. FROM THE OUTER SQUARE HOLE TO THE FRONT

- Peel the masking tape half way back on the application hole.
- Insert the wand forward until the wand hits the bulkhead and spray 1 shot

2016-2017MY

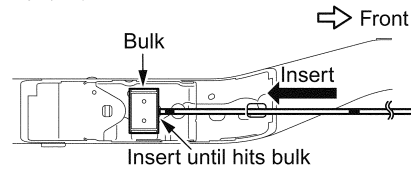

4x2 <Front View>

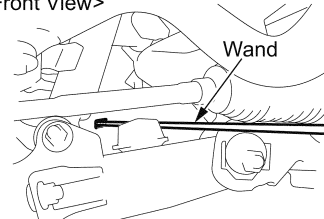

4x4 <Front View>

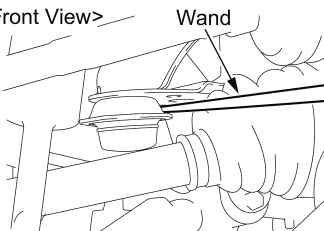

R1807300001001C

- c) Pull back the wand 1 notch and spray 1 shot.

NOTE:

Be cautious as the spraying interval will change because the notches are at both 5 mm (0.197 in.) and 10 mm (0.394 in.) intervals.

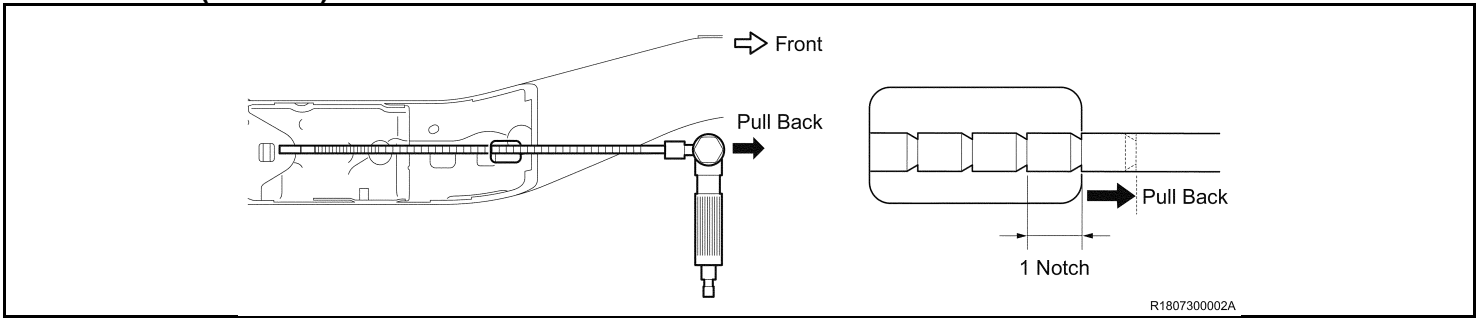

- d) Repeat step c) until Mark 2 appears.
e) When spraying the last few shots, cover the application hole with your hand so that wax does not splash out.
f) Apply masking tape on the application hole.

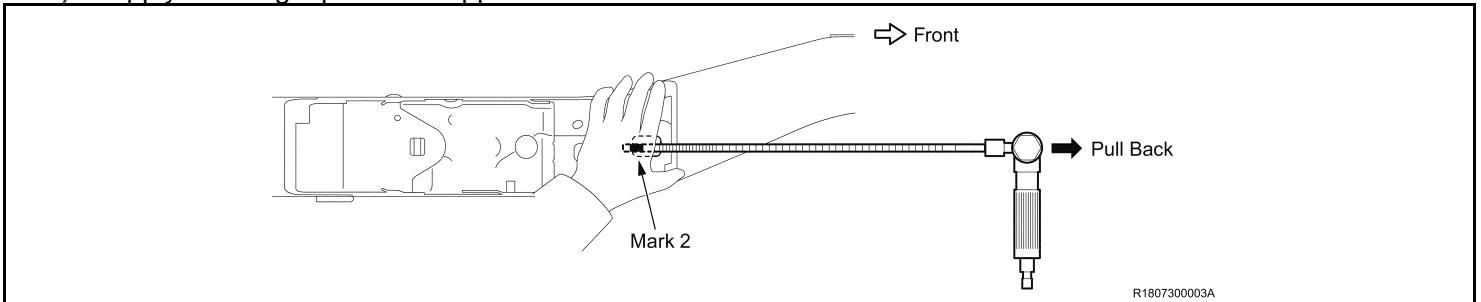

2. REPEAT THE PROCEDURE ON THE OTHER SIDE

- a) Repeat the step 1 on the other side of the frame side rail.

J. APPLY WAX WITH SEALER GUN

* The illustrations show RH side only. Perform the same procedure for LH side.

Confirmation

Before wax application

(Refer to XII. H. 1. PREPARE FOR WAX APPLICATION)

- Wax temperature

LOCATION:

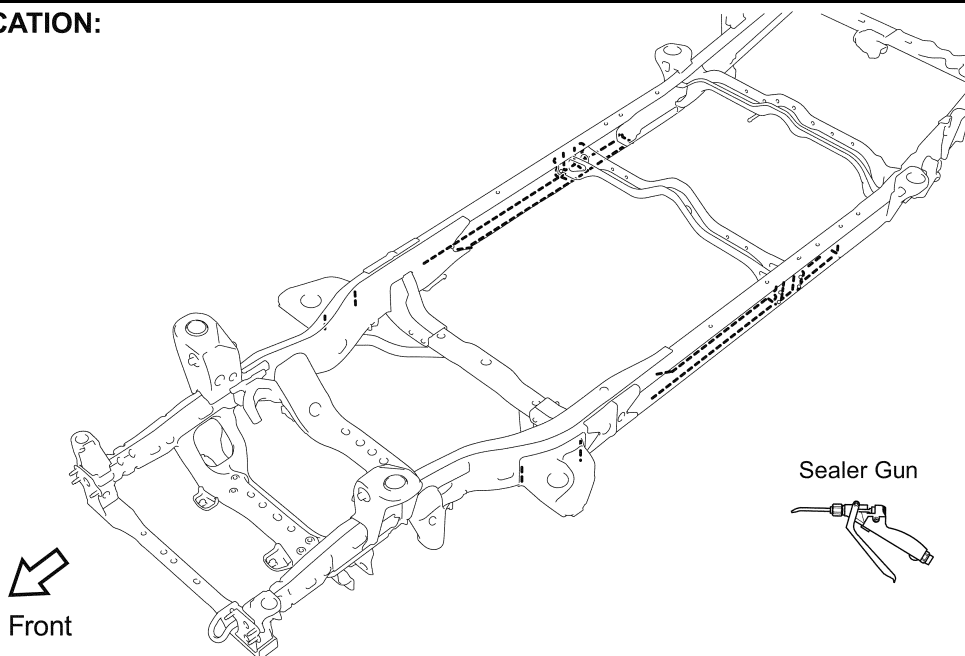

1. AROUND THE REINFORCEMENT AND CROSSMEMBER

- a) Apply wax to the gap and edge between the reinforcement and side rail.

NOTE :

The amount of wax can be visually controlled.

The distance between the crossmember and the reinforcement may vary depending on the vehicle

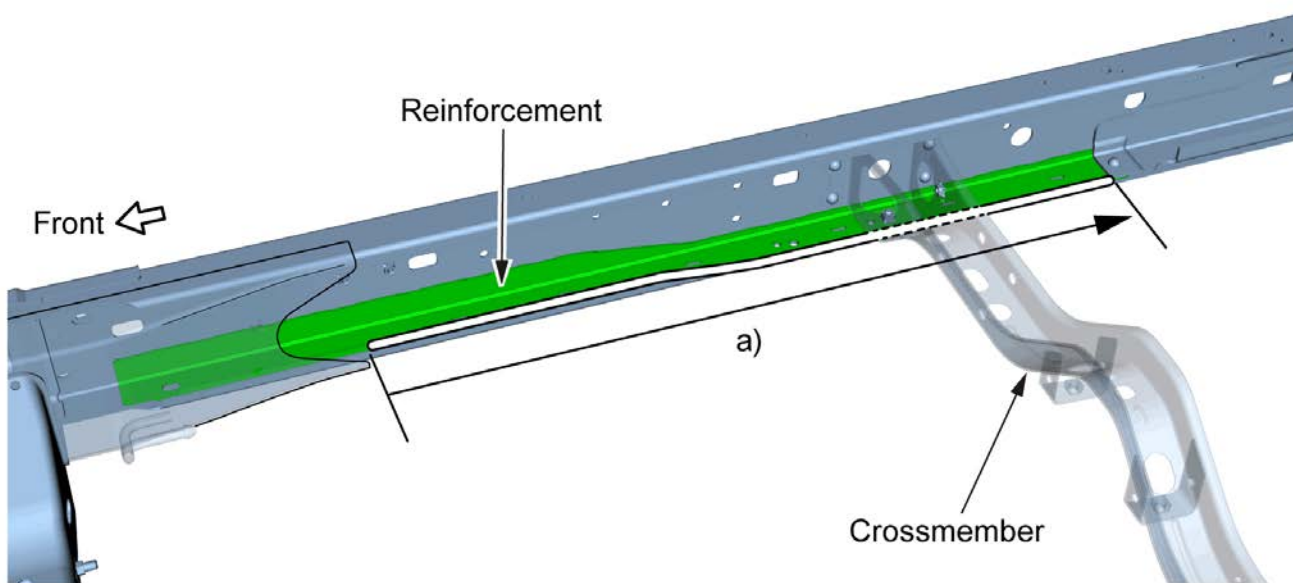

b) Fill wax into the gap between the side rail and reinforcement.

NOTE :

Cover the top of the gun with your hand as shown in the illustration and fill wax enough until it comes out from between the fingers.

c) Fill wax from the upper side of the gap.

NOTE :

Make sure to fill the wax as much as they come out.

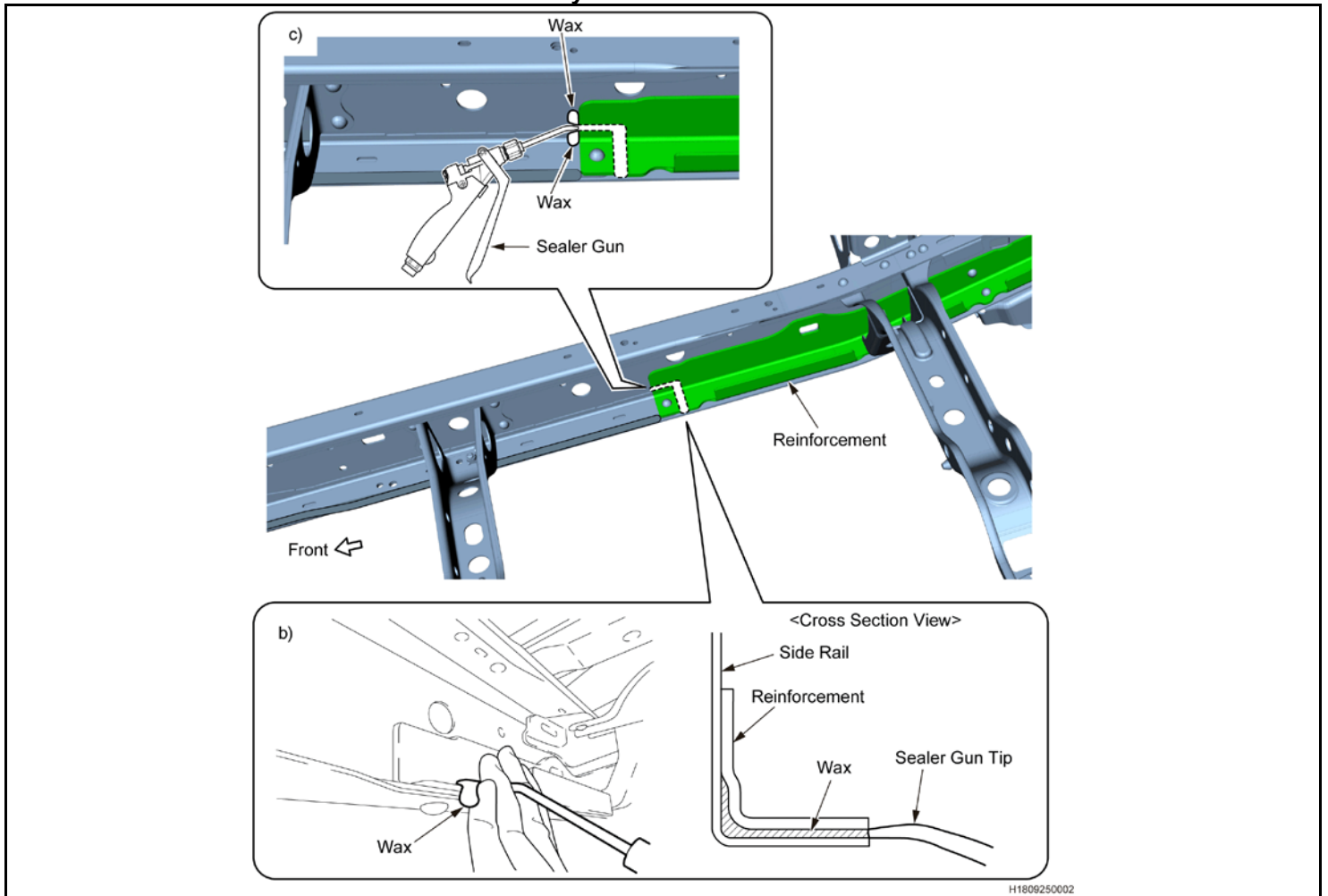

d) Apply wax to the gap and edge between reinforcement and side rail.

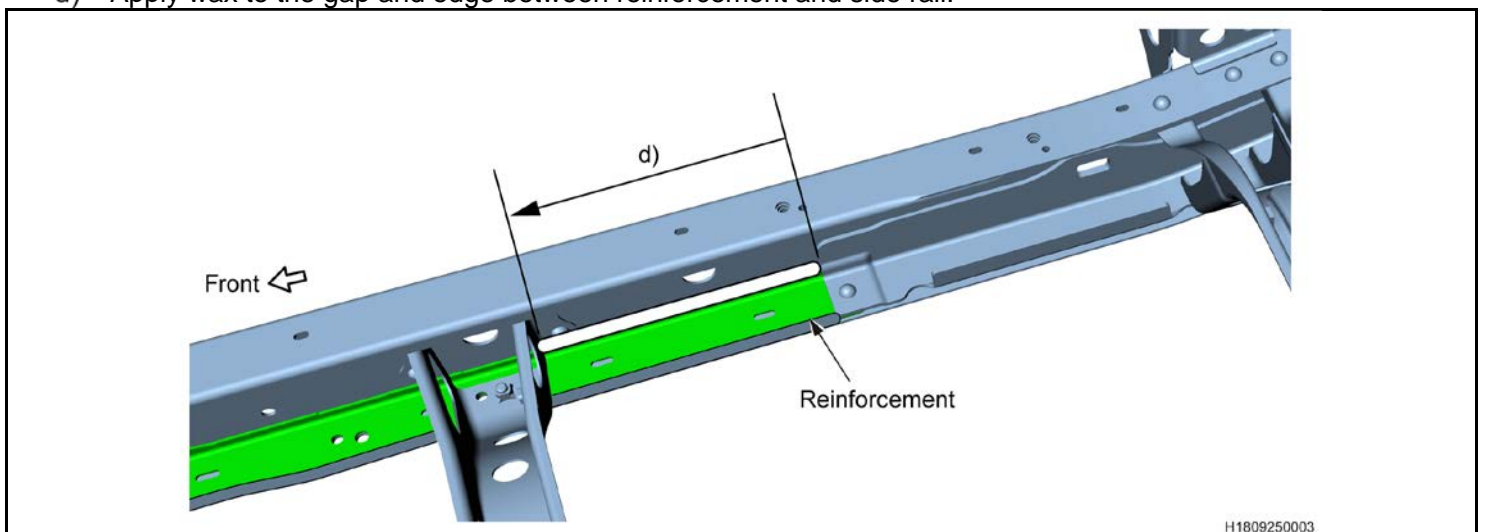

- e) Apply wax to the gap and edge between reinforcement and side rail.
- f) Apply wax to the gap and edge between crossmember and side rail.

NOTE:

- Insert the sealer gun tip from the front and rear hole of the crossmember to apply wax inside the crossmember properly.
- These steps e) and f) are not needed for short wheel base vehicle configuration.

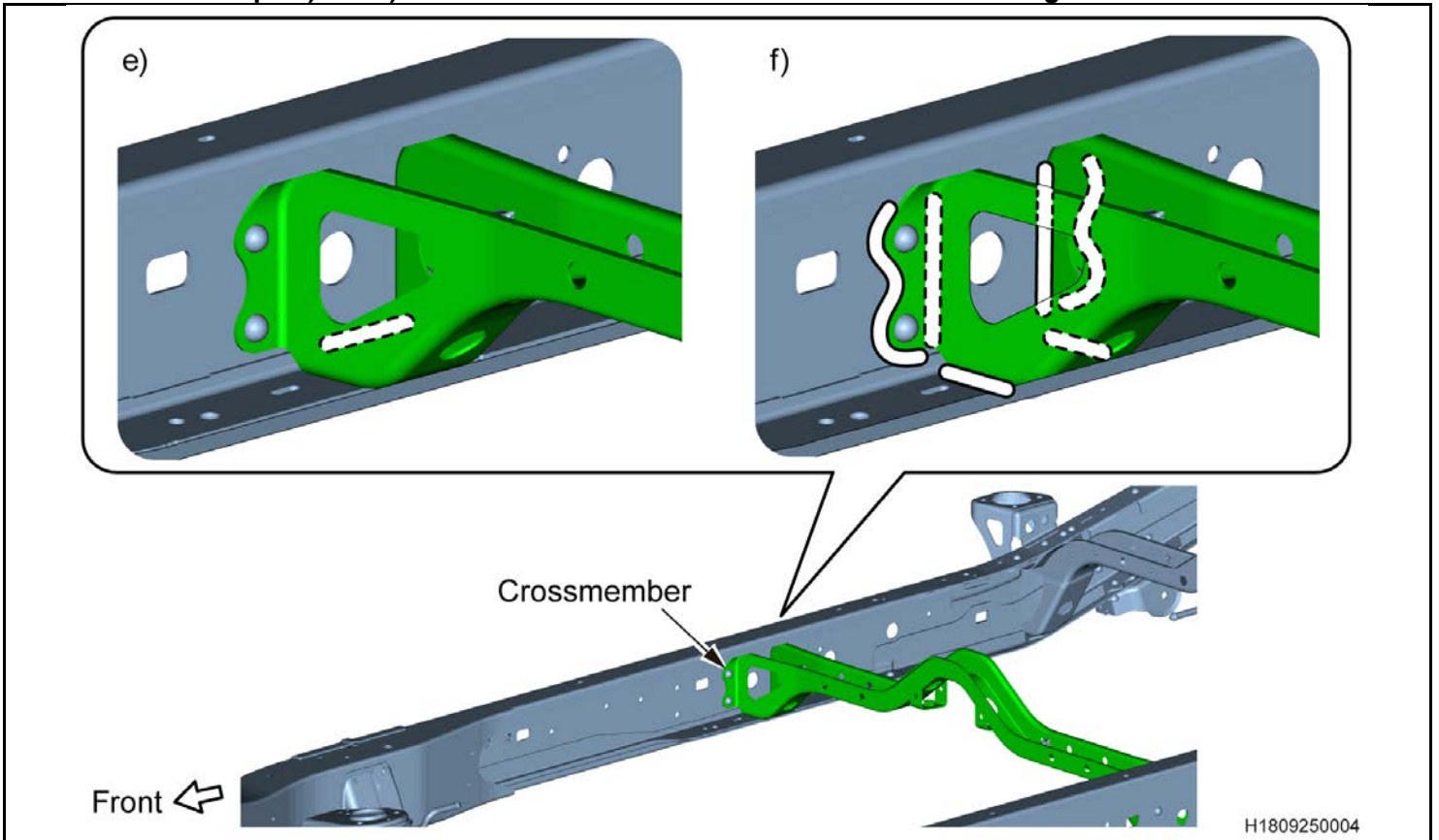

- g) Apply wax to the gap and edge between reinforcement and side rail.

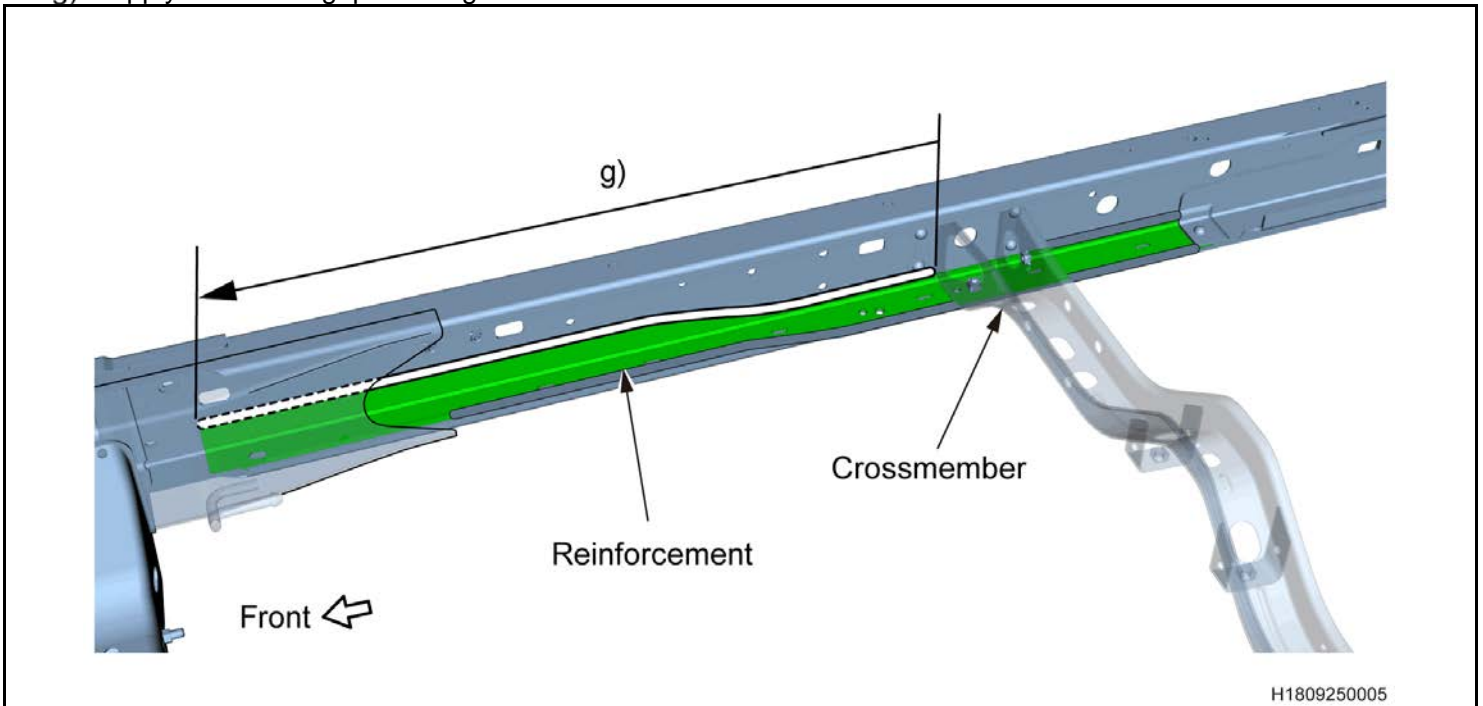

- h) Apply wax to the gap and edge between reinforcement and side rail.
- i) Apply wax to the gap and edge between front inner channel and side rail.

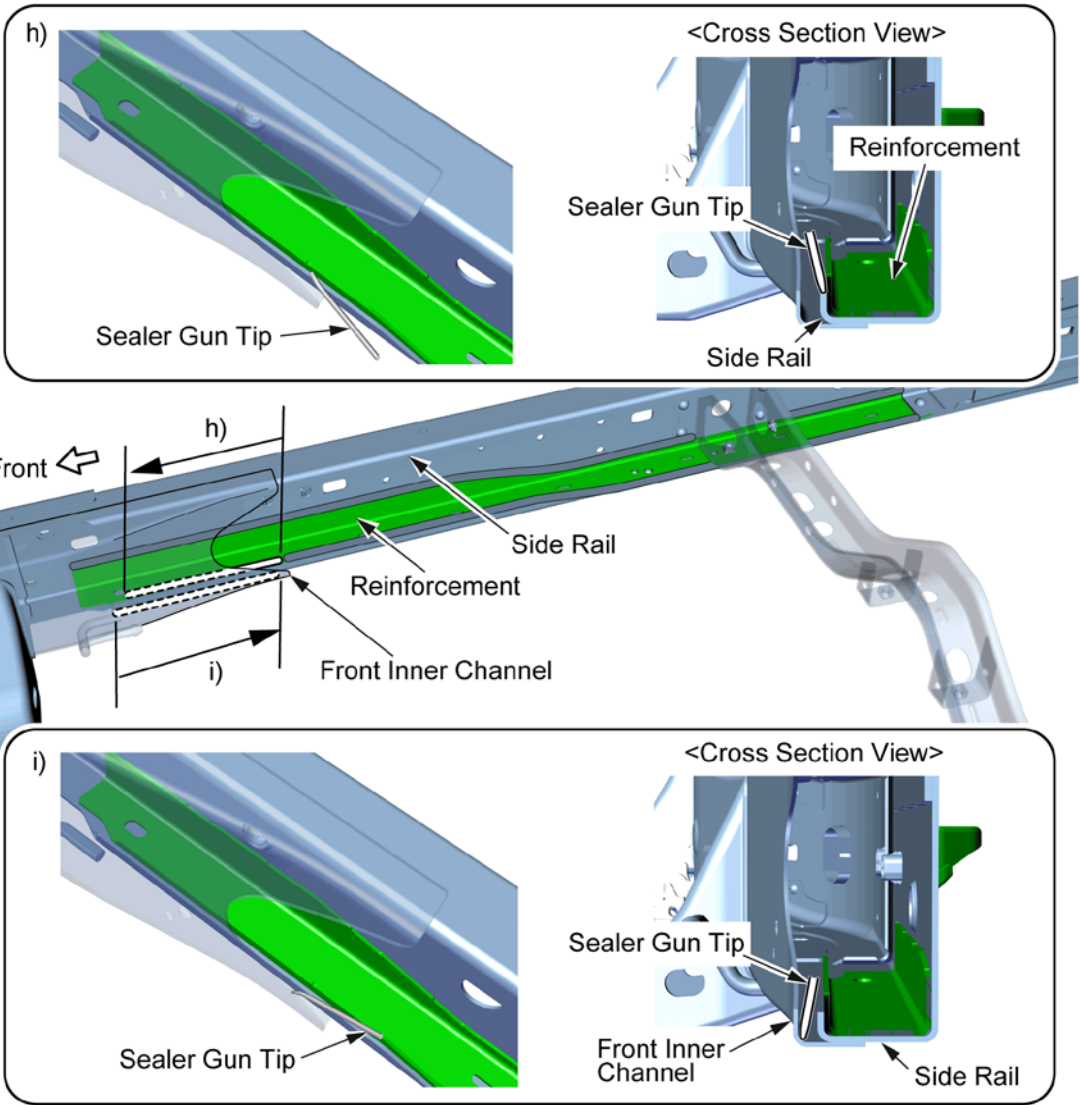

H1809250006

- j) Apply wax to the gap and edge between front inner channel and side rail.

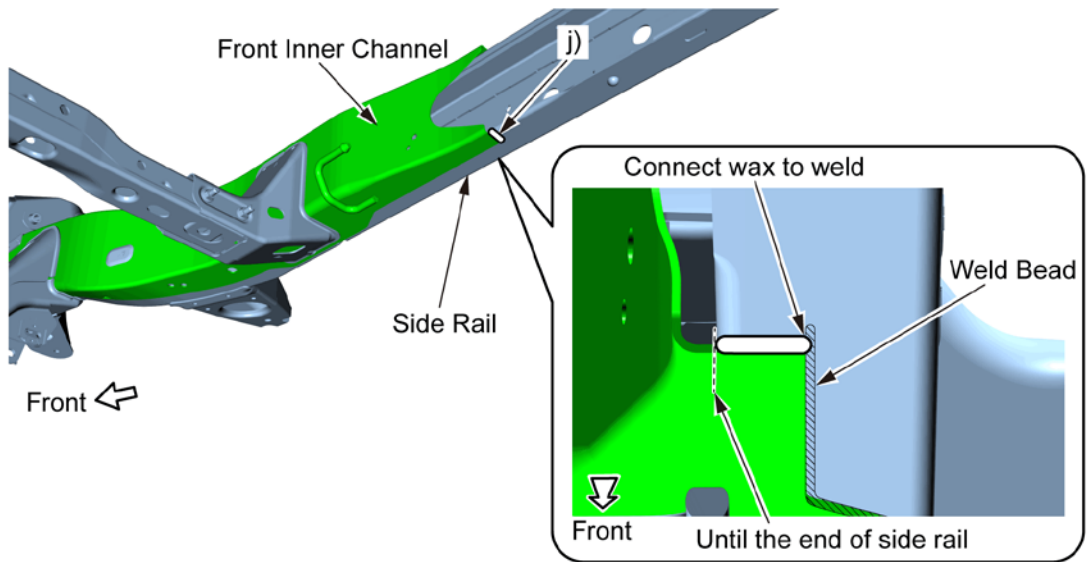

H1809250007

2. INSIDE CAB MOUNT

- a) Insert the sealer gun tip from the holes which are on the bottom surface of the cab mount and apply wax to the gap between the cab mount and side rail.

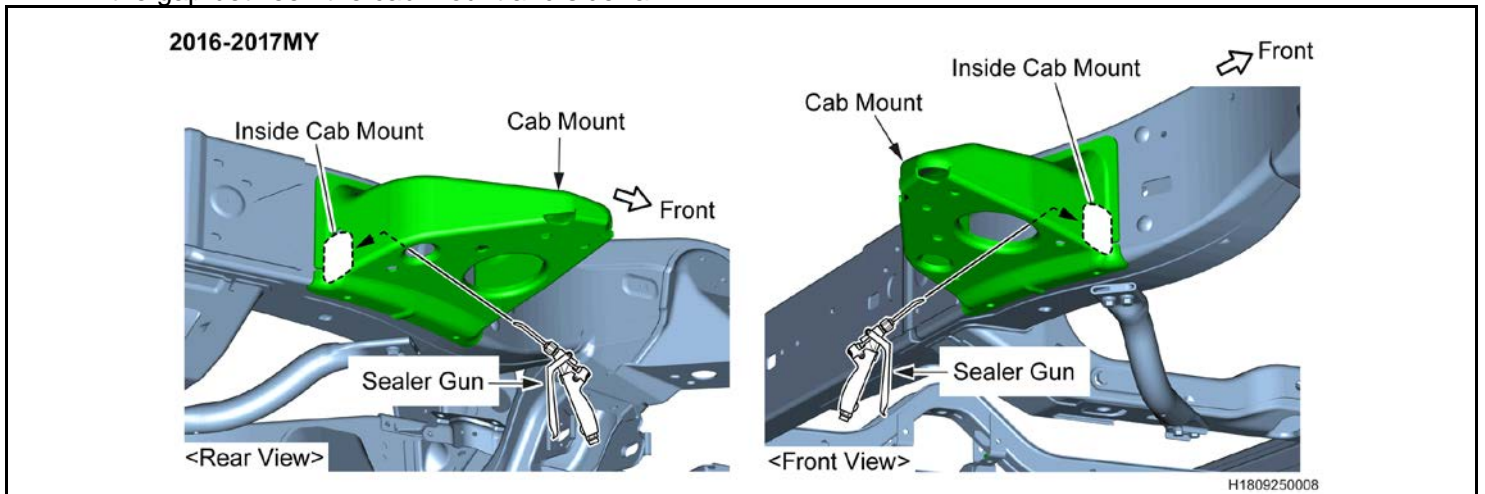

3. REPEAT THE PROCEDURE ON THE OTHER SIDE

- a) Repeat the steps 1 and 2 on the other side of the frame side rail.

4. INSTALL THE BODY PLUGS

- a) Remove the masking tape and scrape out the wax applied around the inside of the plug hole, and then install the **NEW** plug (90950-01A24).



The plug must be installed with the openings facing the side of the vehicle and the tabs facing the front a rear to ensure road spray does not enter the frame through the plug.

- b) Remove the masking tape and install the **NEW** plugs (90950-01991, 90950-01987).

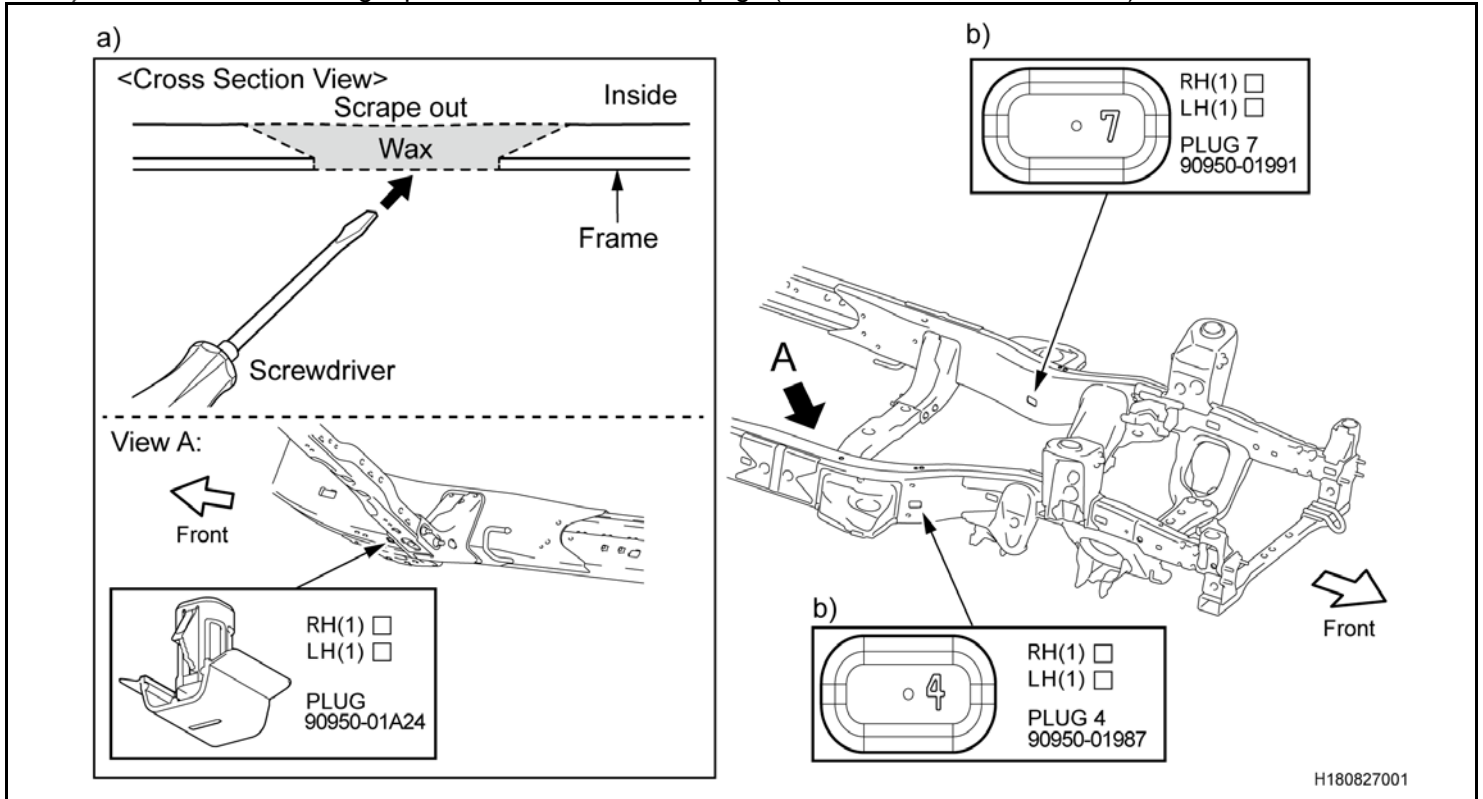

XIII. CHECKSHEET AND RECORD KEEPING

1. COMPLETE POST-SPRAY CHECK SHEET (**THIS MUST BE DONE FOR EVERY VEHICLE**)

- a. Click the link below to access the frame check sheet (**USE IE FOR ALL SUBMISSIONS**)
https://one.tis.toyota.com/t3Portal/frameSprayCheck?l=tis_frame_spray&campaignCode=K0D&vin=&aignId=5&source=tech

NOTE: VEHICLES FOUND WITH AFTERMARKET WAX

Vehicles that come into dealership that already have wax applied from the plant can be determined by using the parts look up site mentioned on page 3. Any vehicle that has had wax application from the plant do NOT require a Checksheet.

Vehicles found with an aftermarket wax sprayed over K0D coverage areas will need a Checksheet completed to determine wax application coverage. Below are examples of aftermarket wax coverage. If you find a vehicle with aftermarket wax send an email to Quality_Compliance@toyota.com for further instruction.

Examples of aftermarket CRC



DRYING
I agree that I have performed drying procedure as outlined in the KOD Technical Instructions

Yes No

Initials

SPRAY CHECK
I agree that I have performed spray pattern check and confirmed weight of wax during check (Subtract the weight of Paint Prep cup and calculate the weight of 1 shot.)
Standard Value: 100 = 120 g (3.53 = 4.23 oz.) [10 = 12 g (0.35 = 0.42 oz.) per shot]

Yes No

Initials

OK Wax are connected **NG** Wax are NOT connected

Single Shot Spray Cup

Choose file No file chosen

Upload a file



b. Answer the questions and enter your initials throughout the check sheet

c. Upload photos to the check sheet

Note:

-All the photos must be taken and have the required parts as shown in the steps below

-All photos must be less than 3MB each

-All photos must be uploaded before the check sheet is completed.

d. **Spray Cup Image**

- Photo must be taken from the top view and show a completed wax ring in the cup
- R.O. Number must be in the picture

e. **Left/Right Inner Box Section Image**

- Photo must be taken at the opening of the box section and show the top, bottom, and side walls of the box section
- R.O. number must be in the picture

NOTE: It is recommended you either use a camera flash or back light to clearly show the interior of the box section

f. **Left/Right Open Section Image**

- Photo must be taken from a distance where the entire wax application along the open section can be seen.
- The R.O. must be in the picture

g. **Left/Right Wheel Well Image**

- Photo must be taken from an angle that has all the plugs installed on the outer rail of the frame
- The R.O. must be in the picture

h. Sign the check sheet

i. Have your Service Manager or Shop Forman sign the check sheet.

j. Submit the check sheet.

k. Using the print function, attached the completed check sheet to the R.O.

STOP A check sheet must be completed for each vehicle sprayed

* I here by confirm that I have performed the CRC wax application as instructed by TMNA. I confirmed the following points during this active and pictures were taken as supporting evidence this repair was performed correctly.

* I have confirmed that this repair was performed correctly and that all the required pictures were taken and saved on the website.

Cancel Submit Reset

XIV. INSTALLATION OF FRAME SEAL

* The illustrations show LH side only. Perform the same procedure for RH side.

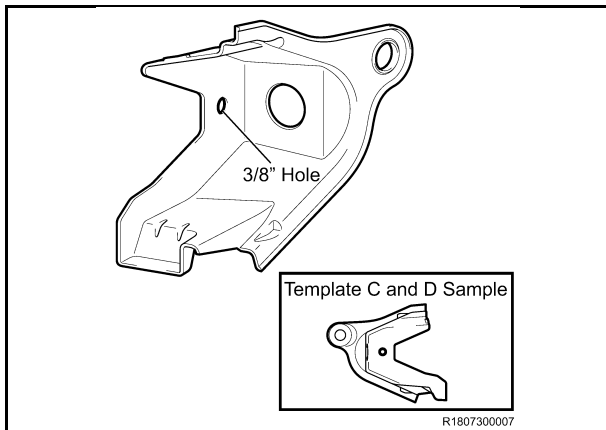

1. INSTALL FRAME RAIL SEAL

a) Using Template C and D, modify both the left and right side frame seal by drilling a (3/8") hole in the location shown.

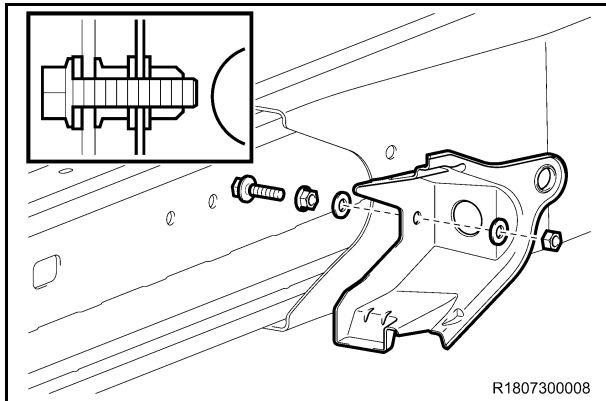

b) Install the bolt through the frame and torque the flange nut.

Torque: 18.5 N*m (189 kgf*cm, 14 ft.*lbf)

c) Install the washer onto the bolt.

d) Install the frame seal second washer and locking nut onto the frame and torque to spec.

Torque: 6.0 N*m (61 kgf*cm, 53 in.*lbf)

Plug Hole Kit CRC Application 2 (2016-2017MY)

Part #	Part Name	Qty
94183-00831	Nut, Lock	2
94611-10800	Washer, Plate	4

Plug Hole Kit CRC Application 4 (2016-2017MY)

Part #	Part Name	Qty
90178-A0112	Nut, Flange	2
90105-A0356	Bolt, Flange	2
5114A-04010	Seal, Frame Side Rail, RH	1
5114B-04010	Seal, Frame Side Rail, LH	1

XV. RESTORATION WORKS

1. RESTORE THE VEHICLE

- Remove all the remaining masking materials.
- Wipe off all the unnecessary wax remaining on the vehicle.
- Reinstall all the removed parts.
- Reinstall wheels and torque to spec.

Steel Wheel / Aluminum Wheel

Torque: 113 N*m (1152 kgf*cm, 83 ft.*lbf)

e) Lower the vehicle.

RECORD-KEEPING AND OTHER REQUIREMENTS

To make sure that your dealership can satisfy specific state and local requirements, please refer to your specific state Dealer Information Packet.

XVI. APPENDIX

A. WAND TIP CLEANING

B. PLUG CHECKSHEET AND FISHTALE COVER TEMPLATES

C. NOX-RUST 712THV-T SDS

A. WAND TIP CLEANING

* The illustrations show the short wand tip; However, the process can be used for the long wand tip as well.



1. REMOVE TIP

- Remove tip from the wand by using wrench.
- Wipe off the wax on outer surface of the tip



2. REMOVE WAX

- Blow air into each orifice to remove wax and any foreign material
- Repeat air-blow until as much material can be removed as possible

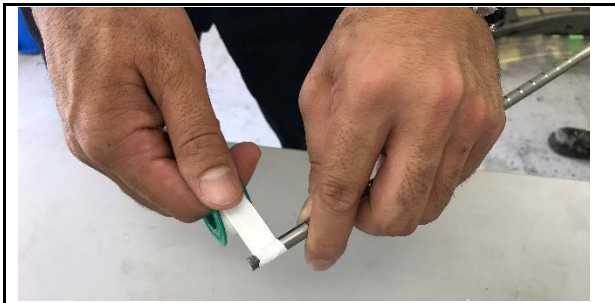

3. RE-ASSEMBLE WAND

- Tape the wand thread by sealant tape.

Reference: Tape the thread twice



The sealant tape should not be applied near the end of the threads to avoid sealant tape entering the wand.

- Assemble the tip and wand by wrench until the end of tip is 24mm from 1st notch. (See picture)
- Adjust the tip angle to meet the top mark on the tip and top mark on the wand. (the long wand tip may not have marks to align. In that case adjust the end of the tip to be 24mm from the first notch)

Note : Only adjust the tip angle when tightening



The 24mm distance between the end of the tip and the first notch is critical for a proper spray pattern

- Check spray pattern to confirm tip is no longer clogged. If clogged repeat step one through 3.

Note: If the tip cannot be unclogged after multiple attempts call the *Bosch Technical Assistance Line - 1-800-933-8335 (Option 4)* to order a new wand.

35

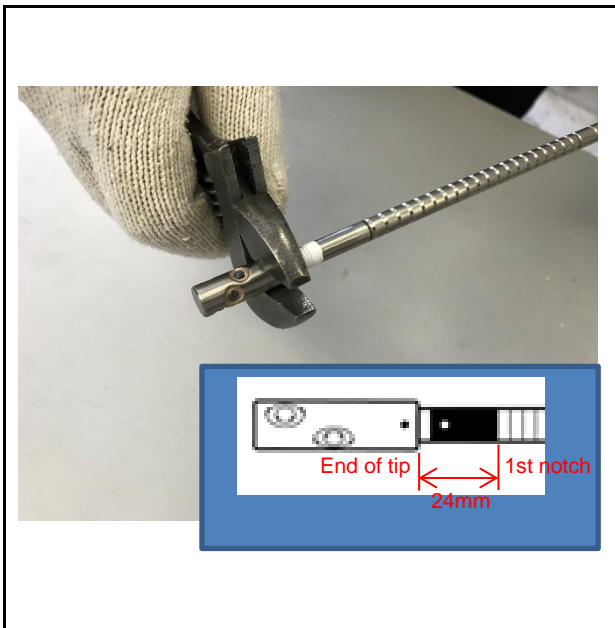

Hole Plugs Installation Check Sheet

for 16-17MY

Please make sure to install the 6 plugs indicated with stars (★) AFTER wax application.

View A:

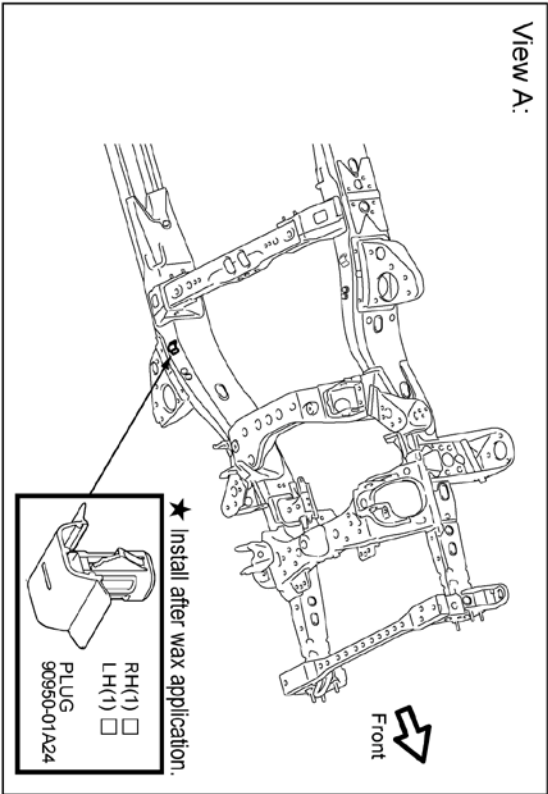

RH(1)
LH(1)
PLUG
90950-A1009

RH(3)
LH(1)
PLUG
90333-30002

★ Install after wax application.
RH(1)
LH(1)
PLUG 7
90950-01991

TR E/G model
RH(1)
GR E/G model
LH(1)
PLUG
90950-01931

RH(1)
LH(1)
PLUG 8
90950-01990

RH(1)
LH(1)
PLUG 4
90950-01987

RH(1)
LH(1)
PLUG 20
90950-01A25

RH(2)
LH(2)
PLUG
90950-01631

★ Install after wax application.
RH(1)
LH(1)
PLUG 4
90950-01987

RH(1)
LH(1)
PLUG 4
90950-01987

RH(1)
LH(1)
PLUG
90080-46327

Front

Front

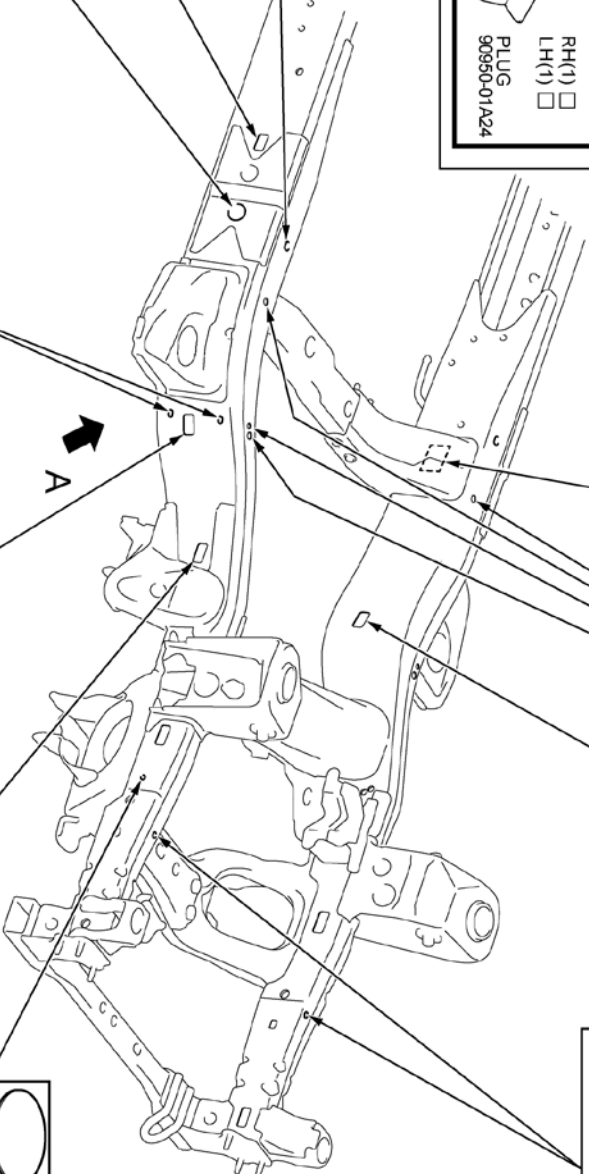

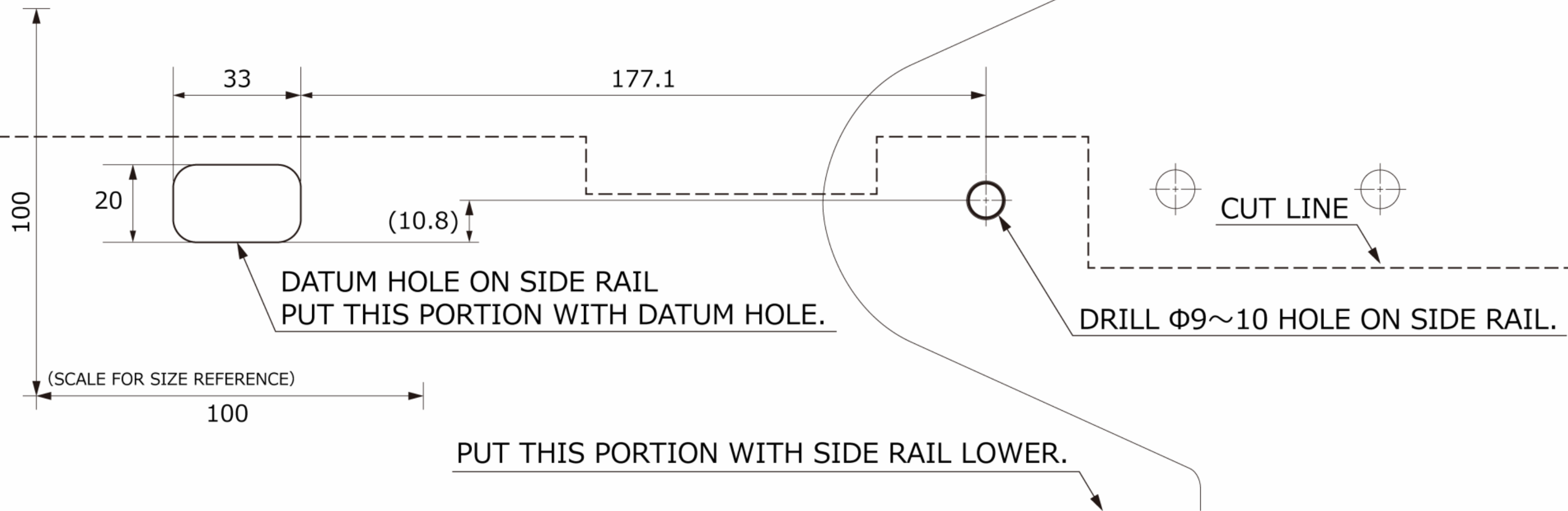

DATUM HOLE ON SIDE RAIL
PUT THIS PORTION WITH DATUM HOLE.

DRILL $\Phi 9 \sim 10$ HOLE ON SIDE RAIL.

PUT THIS PORTION WITH SIDE RAIL LOWER.

CUT LINE

LH
PAPER PATTERN

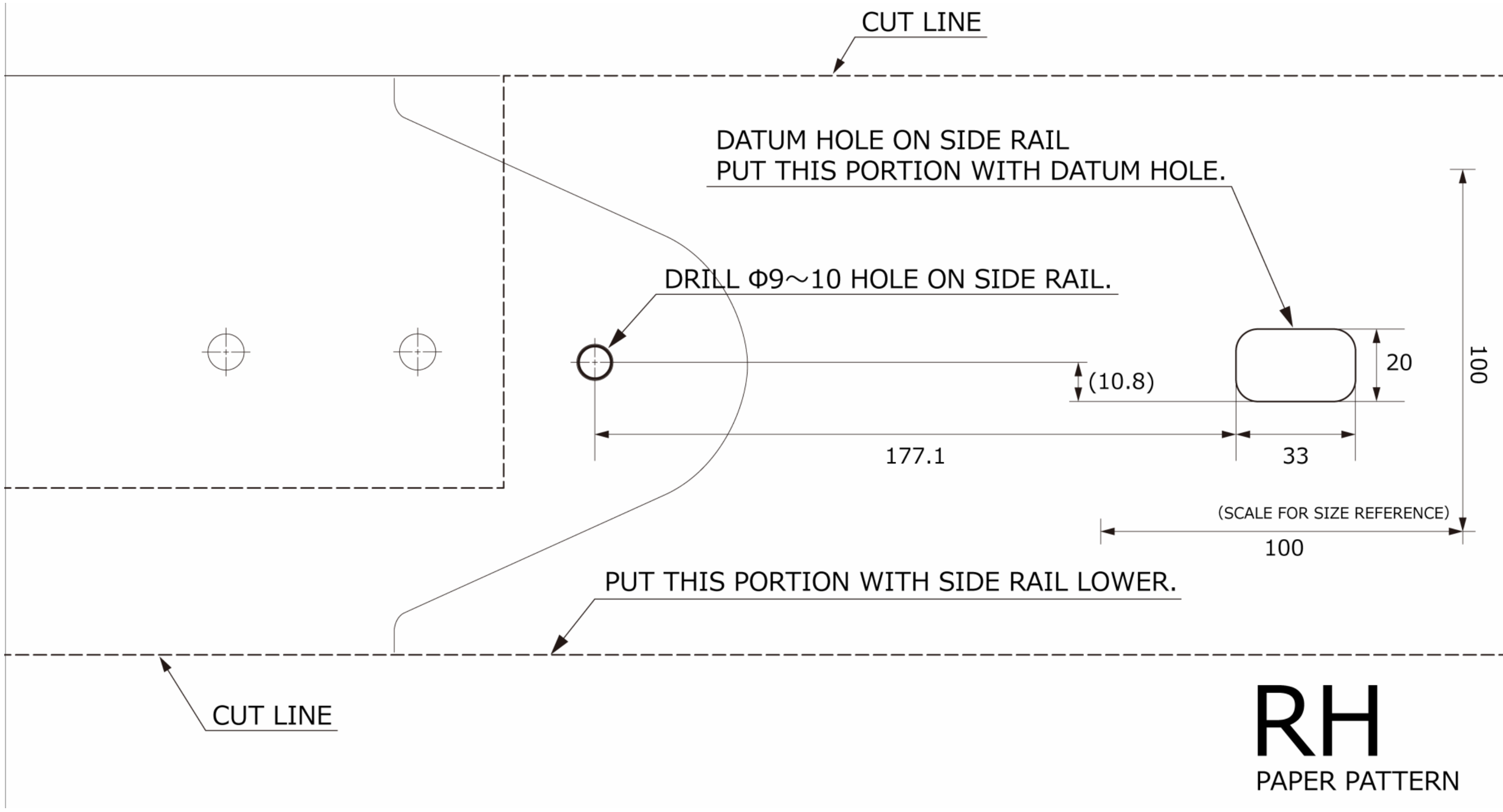

RH
PAPER PATTERN

Template C

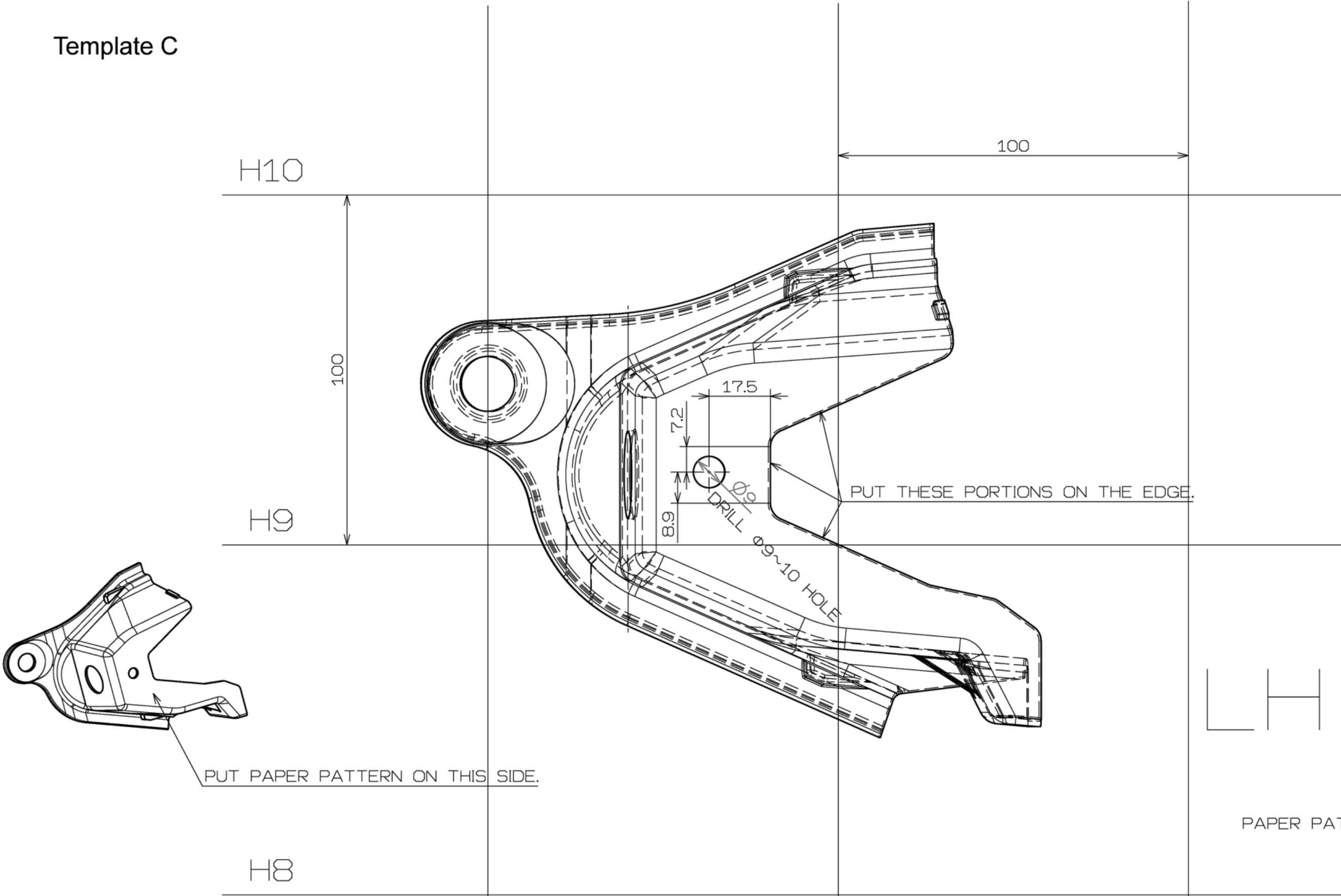

LH

PAPER PATTERN

Template D

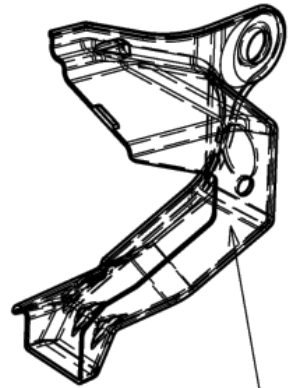

PUT PAPER PATTERN ON THIS SIDE.

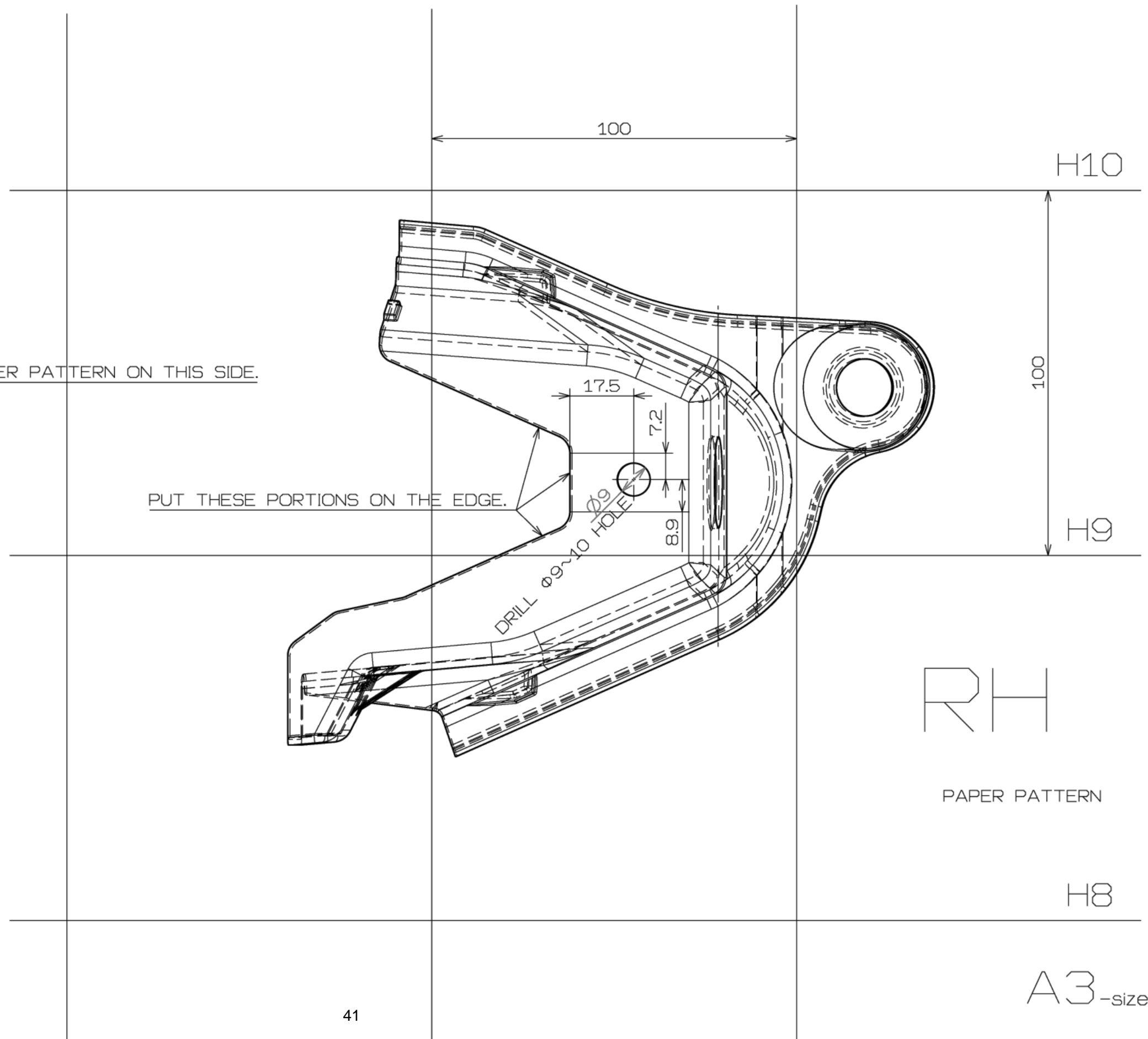

SAFETY DATA SHEET

1. Identification

Product identifier NOX-RUST 712THV-T

Other means of identification

SDS number 135- 0190EN- LS

Recommended use Rust preventing oil

Recommended restrictions None known.

Manufacturer/Importer/Supplier/Distributor information

Supplier

Company name NIHON PARKERIZING CO.LTD

Address 1-15-1 NIHONBASHI, Chuo-ku, Tokyo, JAPAN

Telephone +81 (3) 3278-4394

e-mail SDS@parker.co.jp

Emergency telephone number Chemtrec: (800)424-9300

2. Hazard(s) identification

Physical hazards Not classified.

Health hazards

Sensitization, skin

OSHA defined hazards Not classified.

Label elements



Signal word Warning

Hazard statement May cause an allergic skin reaction.

Precautionary statement

Prevention

Avoid breathing mist or vapor. Contaminated work clothing must not be allowed out of the workplace. Wear protective gloves.

Response

If on skin: Wash with plenty of water. If skin irritation or rash occurs: Get medical advice/attention. Wash contaminated clothing before reuse.

Storage

None.

Disposal

Dispose of contents/container in accordance with local/regional/national/international regulations.

Hazard(s) not otherwise classified (HNOC)

None known.

Supplemental information

None.

3. Composition/information on ingredients

Mixtures

Chemical name	CAS number	%
Liquid paraffin	Proprietary	42-47

Sulfonic acids, petroleum, calcium salts	61789-86-4	7-12
Natural vegetable fat	Proprietary	8-13

Composition comments All concentrations are in percent by weight unless ingredient is a gas. Gas concentrations are in percent by volume.

4. First-aid measures

Inhalation	Immediately remove from further exposure. Get immediate medical assistance. For those providing assistance, avoid exposure to yourself or others. Use adequate respiratory protection. Give supplemental oxygen, if available. If breathing has stopped, assist ventilation with a mechanical device.
Skin contact	Remove contaminated clothing immediately and wash skin with soap and water. If skin irritation or rash occurs: Get medical advice/attention.
Eye contact	In the case of contact with eyes, rinse immediately with plenty of water and seek medical advice.
Ingestion	Rinse mouth thoroughly with water and give large amounts of milk or water to people not unconscious. Only induce vomiting at the instruction of medical personnel. Get medical attention if any discomfort continues.
Most important symptoms/effects, acute and delayed	Dermatitis.
Indication of immediate medical attention and special treatment needed	Treat symptomatically.
General information	First aid personnel must be aware of own risk during rescue.

5. Fire-fighting measures

Suitable extinguishing media	Use fire-extinguishing media appropriate for surrounding materials.
Unsuitable extinguishing media	None known.
Specific hazards arising from the chemical	By heating and fire, harmful vapors/gases may be formed.
Special protective equipment and precautions for firefighters	Selection of respiratory protection for firefighting: follow the general fire precautions indicated in the workplace. Self-contained breathing apparatus and full protective clothing should be worn when fighting chemical fires.
Fire fighting equipment/instructions	Use standard firefighting procedures and consider the hazards of other involved materials.
General fire hazards	Will burn if involved in a fire.

6. Accidental release measures

Personal precautions, protective equipment and emergency procedures	Provide adequate ventilation. Evacuate area. Avoid inhalation of vapors and contact with skin and eyes. Wear protective clothing as described in Section 8 of this safety data sheet.
Methods and materials for containment and cleaning up	Absorb spillage with suitable absorbent material.
Environmental precautions	Prevent further leakage or spillage if safe to do so. Avoid discharge into drains, water courses or onto the ground. Contact local authorities in case of spillage to drain/aquatic environment.

7. Handling and storage

Precautions for safe handling	Provide adequate ventilation. Avoid inhalation of vapors and contact with skin and eyes. Wear appropriate personal protective equipment. Wash hands after handling. Observe good industrial hygiene practices.
Conditions for safe storage, including any incompatibilities	Keep container tightly closed and in a well-ventilated place. Keep away from heat and sources of ignition.

2

8. Exposure controls/personal protection

Occupational exposure limits

U.S. OSHA Table Z-1 Limits for Air Contaminants (29 CFR 1910.1000)

Components	Type	Value	Form
Liquid paraffin	PEL	5 mg/m ³	Mist.
Sulfonic acids, petroleum, calcium salts	N/A	N/A	N/A
Natural vegetable fat	N/A	N/A	N/A

U.S. ACGIH Threshold Limit Values

Components	Type	Value	Form
Liquid paraffin	TWA	5 mg/m ³	Inhalable fraction.
Sulfonic acids, petroleum, calcium salts	N/A	N/A	N/A
Natural vegetable fat	N/A	N/A	N/A

U.S. NIOSH: Pocket Guide to Chemical Hazards

Components	Type	Value	Form
Liquid paraffin	Ceiling	1800 mg/m ³	
	STEL	10 mg/m ³	Mist.
	TWA	5 mg/m ³	Mist.
Sulfonic acids, petroleum, calcium salts	N/A	N/A	N/A
Natural vegetable fat	N/A	N/A	N/A

Biological limit values	No biological exposure limits noted for the ingredient(s).
Appropriate engineering controls	Mechanical ventilation or local exhaust ventilation is required. Observe Occupational Exposure Limits and minimize the risk of inhalation of vapors. Provide easy access to water supply or an emergency shower.
Individual protection measures, such as personal protective equipment	
Eye/face protection	Wear safety glasses with side shields (or goggles).
Skin protection	
Hand protection	Wear protective gloves. Be aware that the liquid may penetrate the gloves. Frequent change is advisable. Suitable gloves can be recommended by the glove supplier.
Skin protection	
Other	Wear appropriate chemical resistant clothing.
Respiratory protection	Use chemical cartridge protection with appropriate cartridge.
Thermal hazards	Wear appropriate thermal protective clothing, when necessary.
General hygiene considerations	Always observe good personal hygiene measures, such as washing after handling the material and before eating, drinking, and/or smoking. Routinely wash work clothing and protective equipment to remove contaminants.

9. Physical and chemical properties

Appearance

Physical state	Liquid.
Form	Viscous liquid.
Color	Milky white.
Odor	Fatty. Oil.
Odor threshold	Not available.
pH	Not available.
Melting point/freezing point	Not available.
Initial boiling point and boiling range	Not available.
Flash point	410.0 °F (210.0 °C) (Typical)
Evaporation rate	Not available.
Flammability (solid, gas)	Not applicable.

Upper/lower flammability or explosive limits

Flammability limit - lower (%)	Not available.
Flammability limit - upper (%)	Not available.
Vapor pressure	Not available.
Vapor density	Not available.
Relative density	1 (15 °C) (Typical)
Solubility(ies)	
Solubility (water)	Slightly soluble in water.
Partition coefficient (n-octanol/water)	Not available.
Auto-ignition temperature	Not available.
Decomposition temperature	Not available.
Viscosity	Not available.
Other information	No data available.

10. Stability and reactivity

Reactivity	The product is stable and non-reactive under normal conditions of use, storage and transport.
Chemical stability	Material is stable under normal conditions.
Possibility of hazardous reactions	Will not occur.
Conditions to avoid	Excessive heat.
Incompatible materials	None.
Hazardous decomposition products	Carbon oxides. Nitrogen oxides.

11. Toxicological information

Information on likely routes of exposure

Inhalation	In high concentrations, vapors are narcotic and may cause headache, fatigue, dizziness and nausea.
Skin contact	Frequent or prolonged contact may defat and dry the skin, leading to discomfort and dermatitis. May cause an allergic skin reaction.
Eye contact	Prolonged or repeated exposure may cause severe irritation.
Ingestion	May cause discomfort if swallowed.
Symptoms related to the physical, chemical and toxicological characteristics	Dermatitis.

Information on toxicological effects

Acute toxicity

Components	Species	Test Results
Sulfonic acids, petroleum, calcium salts (CAS 61789-88-4)		
<u>Acute</u>		
Dermal		
LD50	Rabbit	>= 4000 mg/kg
Inhalation		
LC50	Rat	>= 5 mg/l
Oral		
LD50	Rat	>= 5000 mg/kg

Skin corrosion/irritation	Causes skin irritation.
Serious eye damage/eye irritation	Causes serious eye irritation.
Respiratory or skin sensitization	
Respiratory sensitization	No data available.
Skin sensitization	May cause an allergic skin reaction.
Germ cell mutagenicity	No data available.
Carcinogenicity	No data available.
IARC Monographs. Overall Evaluation of Carcinogenicity	
Not listed.	
NTP Report on Carcinogens	
Not listed.	
OSHA Specifically Regulated Substances (29 CFR 1910.1001-1053)	
Not regulated.	

Reproductive toxicity	No data available.
Specific target organ toxicity - single exposure	No data available.
Specific target organ toxicity - repeated exposure	No data available.
Aspiration hazard	No data available.

12. Ecological information

Ecotoxicity The product is not classified as environmentally hazardous. However, this does not exclude the possibility that large or frequent spills can have a harmful or damaging effect on the environment.

Components	Species	Test Results
Sulfonic acids, petroleum, calcium salts (CAS 61789-88-4)		
Aquatic		
Crustacea	EC50 Daphnia	10 - 100 mg/l, 48 Hours
Fish	LC50 Fathead minnow (<i>Pimephales promelas</i>)	10 - 100 mg/l, 96 Hours
Persistence and degradability	No data available.	
Bioaccumulative potential	No data available.	
Mobility in soil	No data available.	
Other adverse effects	No data available.	

13. Disposal considerations

Disposal instructions	Dispose of in accordance with local regulations. Avoid discharge into water courses or onto the ground.
Hazardous waste code	The waste code should be assigned in discussion between the user, the producer and the waste disposal company.
Waste from residues / unused products	Disposal recommendations are based on material as supplied. Disposal must be in accordance with current applicable laws and regulations, and material characteristics at time of disposal.
Contaminated packaging	Since emptied containers retain product residue, follow label warnings even after container is emptied.

14. Transport information

DOT	Not regulated as dangerous goods.
IATA	Not regulated as dangerous goods.
IMDG	Not regulated as dangerous goods.

Transport in bulk according to Annex II of MARPOL 73/78 and the IBC Code Not available.

15. Regulatory information

US federal regulations This product is a "Hazardous Chemical" as defined by the OSHA Hazard Communication Standard, 29 CFR 1910.1200.

TSCA Section 12(b) Export Notification (40 CFR 707, Subpt. D)

Not regulated.

CERCLA Hazardous Substance List (40 CFR 302.4)

Not listed.

SARA 304 Emergency release notification

Not regulated.

OSHA Specifically Regulated Substances (29 CFR 1910.1001-1053)

Not regulated.

Superfund Amendments and Reauthorization Act of 1986 (SARA)

SARA 302 Extremely hazardous substance

Not listed.

SARA 311/312 Hazardous chemical Yes

Classified hazard categories Respiratory or skin sensitization

SARA 313 (TRI reporting)

Not regulated.

Other federal regulations

Clean Air Act (CAA) Section 112 Hazardous Air Pollutants (HAPs) List

Not regulated.

Clean Air Act (CAA) Section 112(r) Accidental Release Prevention (40 CFR 68.130)

Not regulated.

Safe Drinking Water Act (SDWA) Not regulated.

US state regulations

US. Massachusetts RTK - Substance List

Liquid paraffin (CAS Proprietary)

US. New Jersey Worker and Community Right-to-Know Act

Liquid paraffin (CAS Proprietary)

US. Pennsylvania Worker and Community Right-to-Know Law

Not listed.

US. Rhode Island RTK

Liquid paraffin (CAS Proprietary)

California Proposition 65

The product contains trace levels of ethylbenzene and methanol, and as a result, California Proposition 65 may require a warning as follows:

WARNING: "This product can expose you to chemicals including ethylbenzene, which is known to the State of California to cause cancer, and methanol, which is known to the State of California to cause birth defects or other reproductive harm. For more information go to www.P65Warnings.ca.gov."

This product contains quartz, but it is physically bound in the wax matrix and not available for exposure.

US. California. Candidate Chemicals List. Safer Consumer Products Regulations (Cal. Code Regs, tit. 22, 69502.3, subd. (a))

Liquid paraffin (CAS Proprietary)

International Inventories

Country(s) or region	Inventory name	On inventory (yes/no)*
	Australian Inventory of Chemical Substances (AICS)	Yes
	Domestic Substances List (DSL)	Yes
	Non-Domestic Substances List (NDSL)	No
	Inventory of Existing Chemical Substances in China (IECSC)	Yes
Europe	European Inventory of Existing Commercial Chemical Substances (EINECS)	Yes
Europe	European List of Notified Chemical Substances (ELINCS)	No
Japan	Inventory of Existing and New Chemical Substances (ENCS)	Yes
Korea	Existing Chemicals List (ECL)	Yes
New Zealand	New Zealand Inventory	Yes
Philippines	Philippine Inventory of Chemicals and Chemical Substances (PICCS)	Yes
Taiwan	Taiwan Chemical Substance Inventory (TCSI)	Yes
United States & Puerto Rico	Toxic Substances Control Act (TSCA) Inventory	Yes

*A "Yes" indicates this product complies with the inventory requirements administered by the governing country(s).

A "No" indicates that one or more components of the product are not listed or exempt from listing on the inventory administered by the governing country(s).

16. Other information, including date of preparation or last revision

Issue date 15-November-2017

Revision date 10-July-2019

Version # 05

NFPA ratings



Disclaimer

This information is provided without warranty. The information is believed to be correct. This information should be used to make an independent determination of the methods to safeguard workers and the environment.