



Quick tip

Version 1.4

February 11th, 2020

Title: Remote start with extended range.

(Only applies to 2019 Tiguan LWB, Jetta, GLI built after CW36/18, Atlas built after CW42/2018, 2020 Arteon)



Remote start kit part number: 3CN065760

Plus

Extended range kit part number: 000065760

Important notes: Only one (1) extended range fob can be programmed to the system at a time. If additional remote start keys are desired, factory standard range remote start key part number 3G0937048 and emergency key part number 3G0959752T DTB must be used. These keys must be ordered with the correct VIN.

Always check ETKA for the latest part numbers.

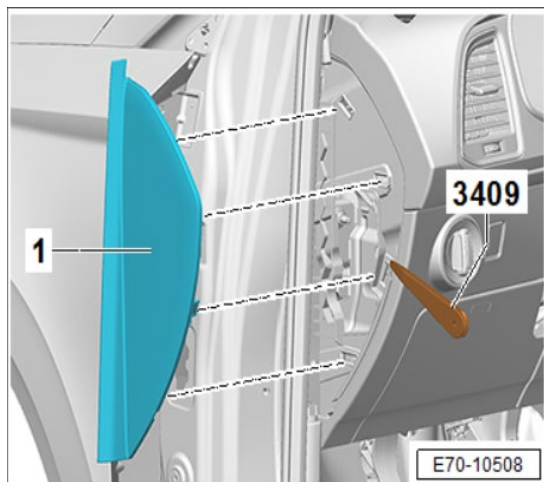

Step 1:

- Bend the door seal molding outward in the instrument panel cover area.
- Pry out the instrument panel side cover -1- with the -3409- near the catches.
- Pull the cover toward the rear and remove it.

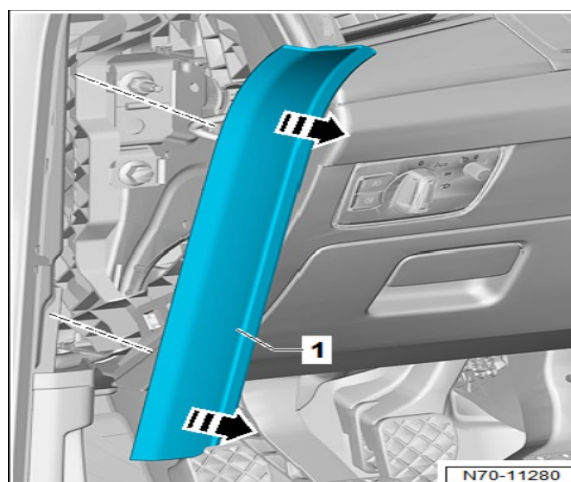

Step 2:

- Unclip the A-pillar gap cover -1- from the A-pillar upper trim panel and A-pillar lower trim panel -arrows-.
- Loosen the A-pillar gap cover -1- from the door seal molding and remove it upward.

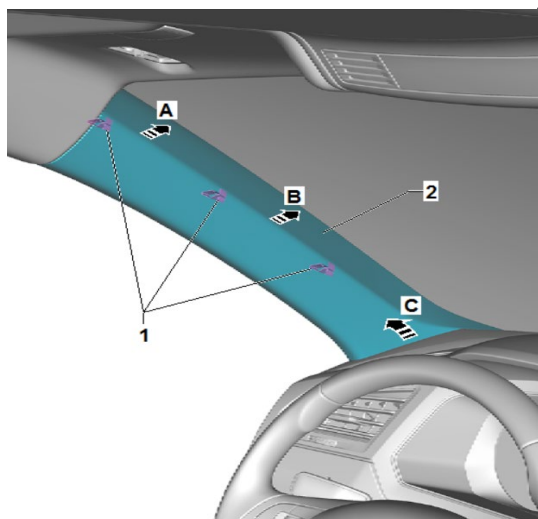

Step 3:

- Remove the A-pillar upper trim panel
- **Note:** Inspect and replace the fasteners if necessary, part numbers 5NA867276B (x2) and 5G0867276A (x1).



Step 4:

- Remove fuse panel cover.

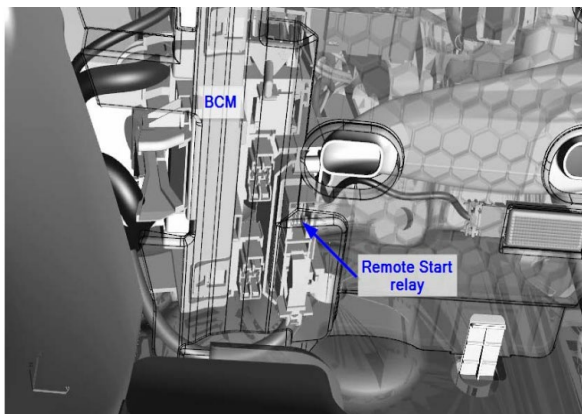

Step 5:

- Locate the Relay labeled -548- and remove it.
- Install the new Relay labeled -526- (comes in the Box).

Original design harness



Step 7a:

- Insert red wire into the fuse holder.
- Insert black/red wire into fuse holder.
- Insert the 2-amp fuse into the fuse holder.

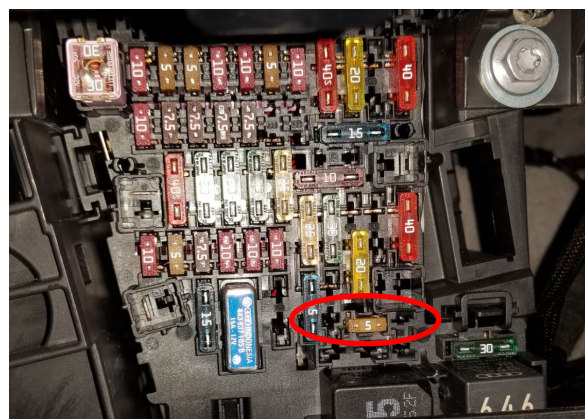

Step 6:

- Locate fuse 49
- Remove and discard.

New design harness

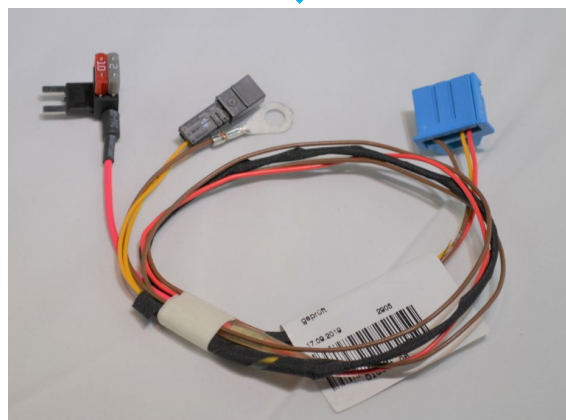

Step 7b:

- No harness preparation is required.

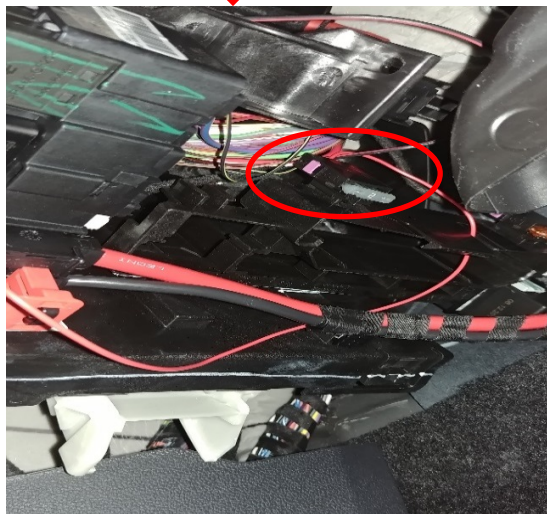

Step 8a:

- Mount the fuse holder to the bracket on the side of the relay panel.

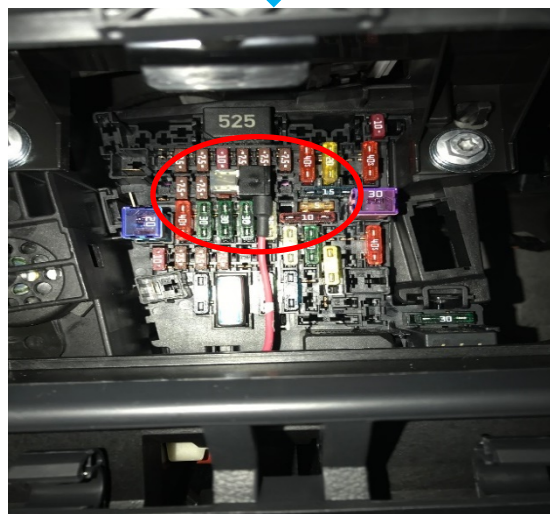

Step 8b:

- Insert fuse holder into location SC20, SC7 or SC8 can be used if there is a fuse larger than 10 amp already in location SC20.



Step 9a:

- Insert the power wire in any open location shown above.

“Always install the product according to the manufacturer's instructions. Modifications to the vehicle or accessory, or improper installation of the accessory can result in damage or failure.”



Original and new design harness



Step 10:

- Use a cable tie and secure the module at the base of A-pillar.



Step 11:

- Route ground wire behind lower A-pillar trim and connect to the chassis ground location under the carpet near the base of A-pillar.

“Always install the product according to the manufacturer's instructions. Modifications to the vehicle or accessory, or improper installation of the accessory can result in damage or failure.”

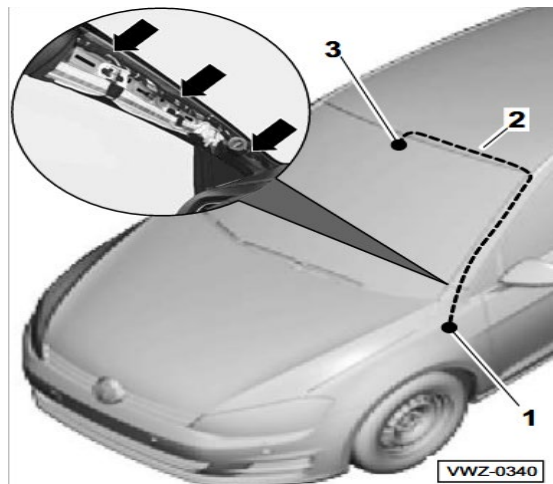
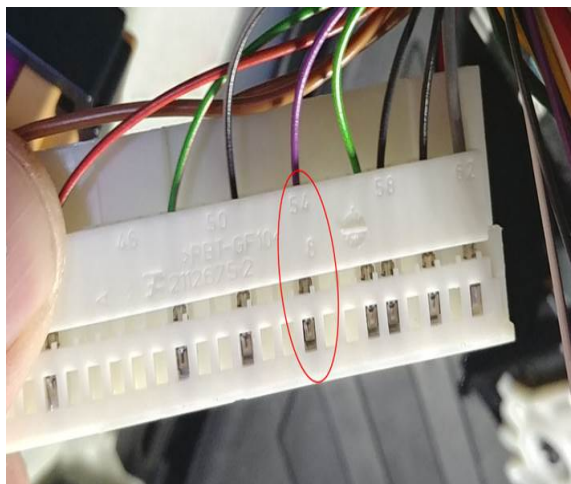

Step 12:

- On white BCM connector, insert line wire from kit into location 54.
- **Note:** If there is already a wire in this location use the provided splice connector.

Step 14:

- Reinstall all trim panels and the BCM connector that was previously removed.

Step 13:

- Route the antenna cable (supplied in the kit) -2- vertically on the left hand side of the mirror mount up to the headliner.
- Tuck the cable behind the headliner and down the "A" pillar and connect it to the module.
- Use the small wire ties -arrows- to secure the cable to the factory harness located within the "A" pillar.

"Always install the product according to the manufacturer's instructions. Modifications to the vehicle or accessory, or improper installation of the accessory can result in damage or failure."



Step 15:

- Connect battery charger/maintainer.
- Connect scan tool.
- Scan the vehicle using GFF.
- Select Special Functions / Adapting software.
- Select Option 2 and enter SVM code 4196 (Jetta only), Code 3FBD V6 engine (Atlas) to update ECM. If vehicle is equipped with 2.0T engine skip this step.
- Select Special Functions / 0009-Remote start
- Select Adapting Software and Option 3 (conversion retrofit with license protection).
- Enter the SWAP keys located in pamphlet provided in remote start kit.
- Select Special Functions / Adapting software.
- Select Adapting Software and Option 2. Enter SVM code 425D to update BCM.

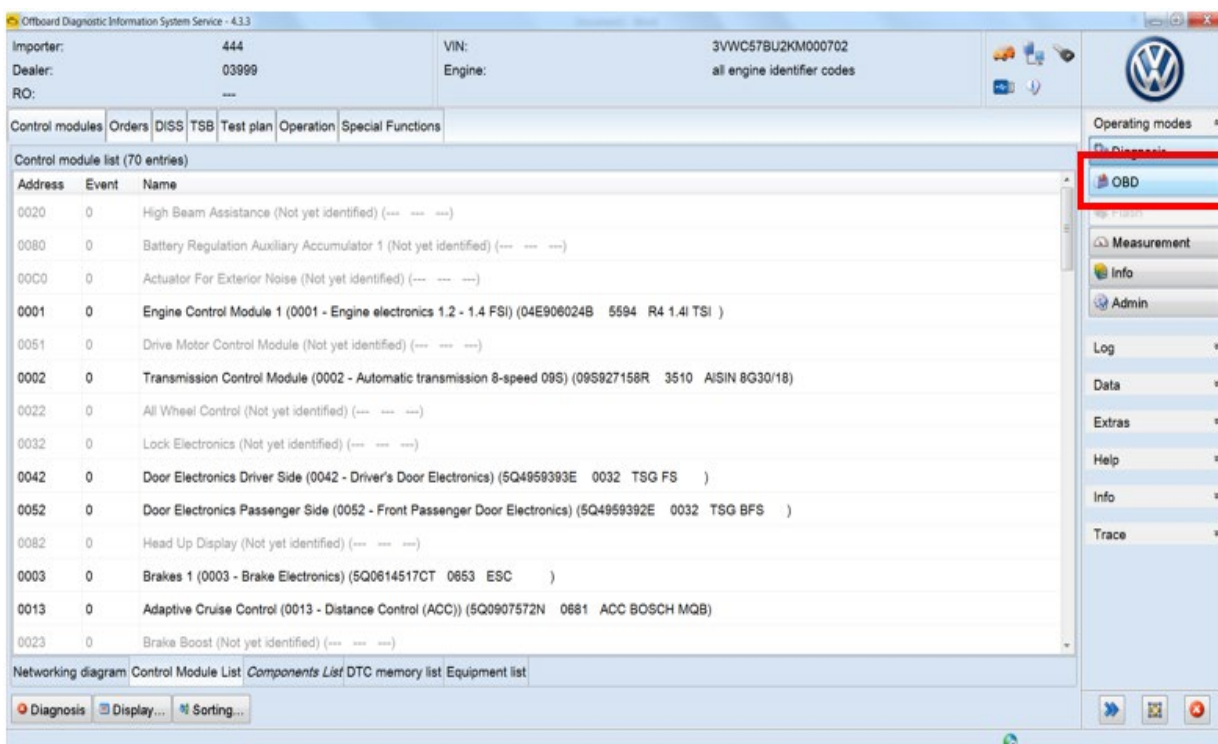

Step 16:

- Select "OBD."

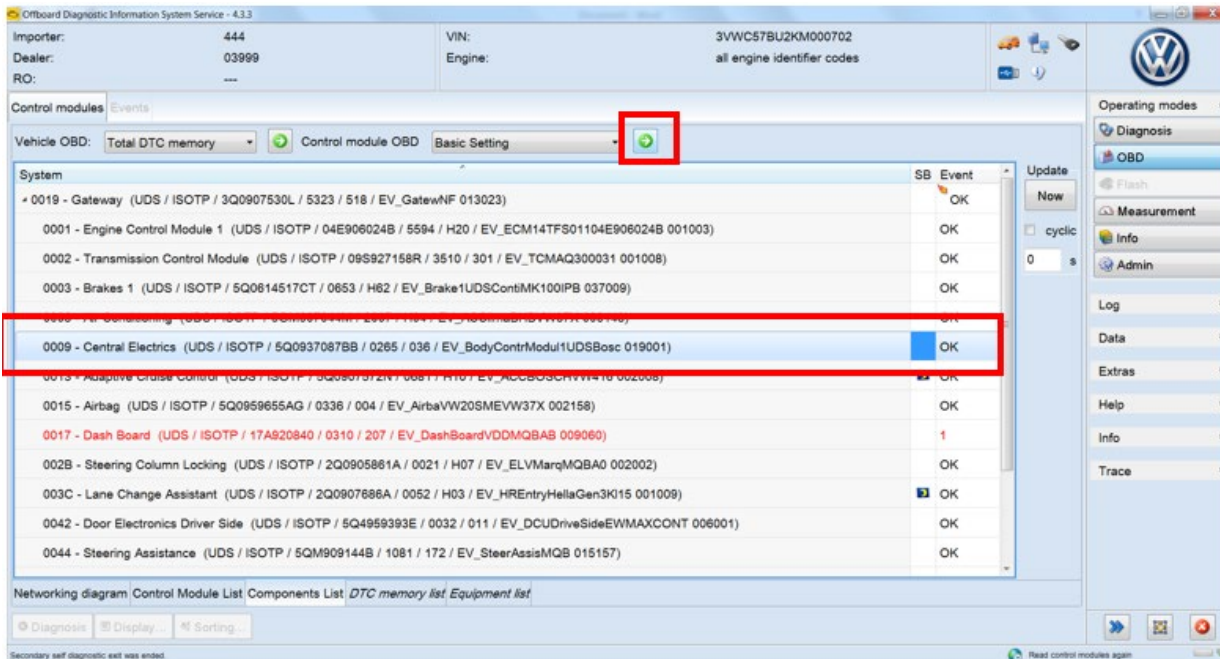

Step 17:

- Select “0009 – Central Electrics” basic settings, then select the “green arrow.”

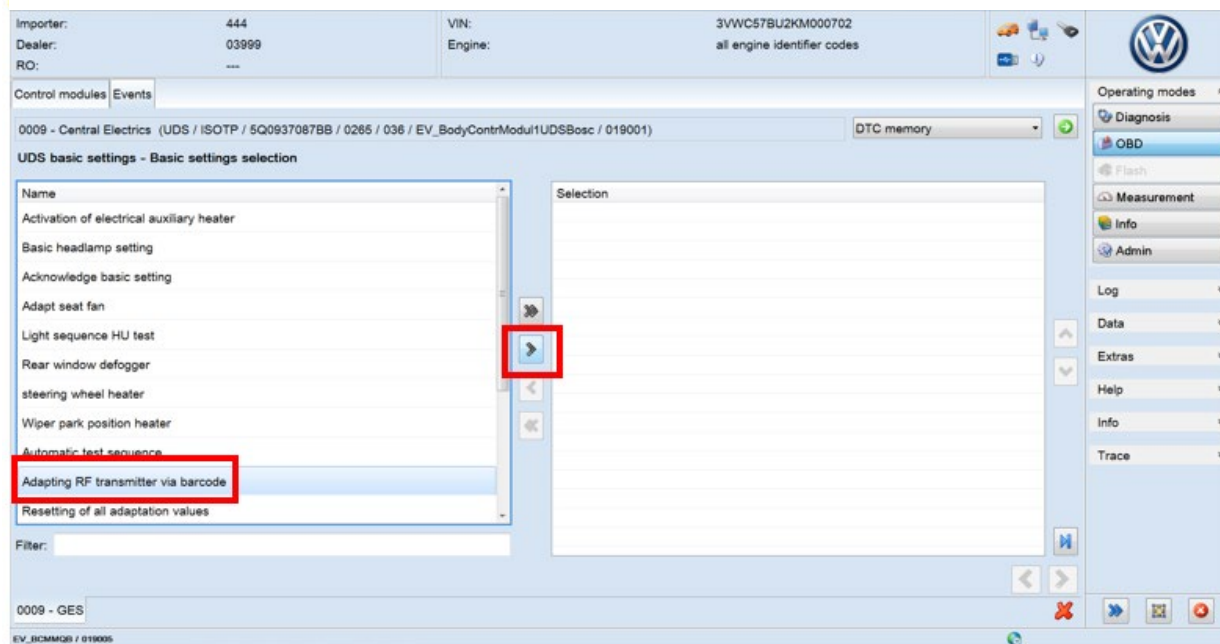

Step 18:

- Select “adapting RF transmitter via barcode” then select the “arrow.”

“Always install the product according to the manufacturer's instructions. Modifications to the vehicle or accessory, or improper installation of the accessory can result in damage or failure.”

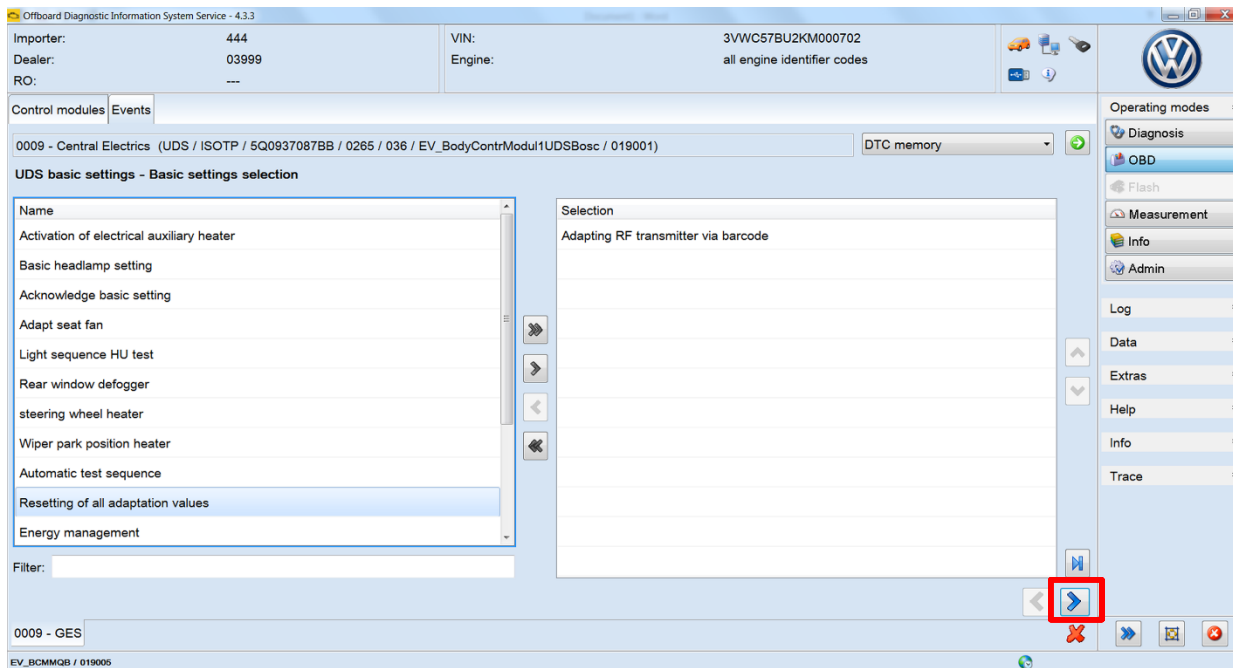

Step 19:

- Select the “next arrow.”

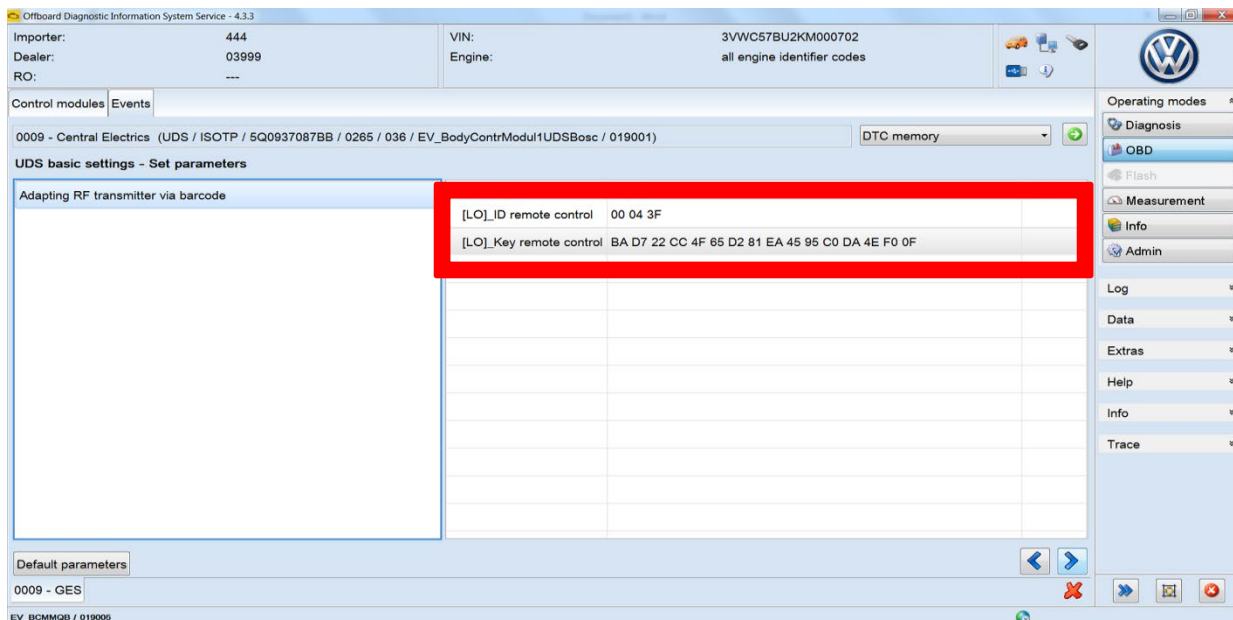

Step 20:

- Enter the RF ID (HEX) and Private key (HEX) either manually with the keyboard or scan the QR code with a scanner.



Step 21:

- Select the “next arrow.”

Step 22:

- Select “Start.”

“Always install the product according to the manufacturer’s instructions. Modifications to the vehicle or accessory, or improper installation of the accessory can result in damage or failure.”



Name	RDID	Status	Result	Value
[IDE06652]_Adapting RF transmitter via barcode	\$0481	[VO]_Routine not active or finished	[VO]_Correct Results	

Name	RDID	Value
------	------	-------

Step 23:

- After selecting “Start,” the result field should change to “[VO] Correct-Results” for a couple seconds. The process is completed.

Step 24:

- To test the operation, close all doors and lock the vehicle, Press the “Info” button once, then press the “Start” button twice on the new transmitter.

Step 25:

- Place the sticker with the RF ID (HEX) and Private key (HEX) on the extended range owner’s manual document. Place the document in the glove box with the owner’s manual.

“Always install the product according to the manufacturer’s instructions. Modifications to the vehicle or accessory, or improper installation of the accessory can result in damage or failure.”



Conditions that will prevent system operation

- Programming failed. Check ETKA or ELSA Pro for new PR code #U2.
- Low fuel light illuminated.
- DTC's in engine, transmission, vehicle electrics, ABS/ESP.
- Key fob/dongle not programmed.
- Vehicle out of range.
- Incorrect button sequence pressed on key fob/dongle.
- Remote start operation has ran 2 cycles without being started with vehicle key.
- Vehicle battery voltage too low.