



Applies To: **1998–2003 Civic GX** – ALL with SCI CNG Fuel Tank Assembly
2004–2011 Civic GX – ALL
2012–2015 Civic Natural Gas – ALL

March 5, 2020

CNG Fuel Tank Solenoid Valve Replacement Process

Supersedes 13-022, dated February 10, 2017, See REVISION SUMMARY

REVISION SUMMARY

This bulletin has been extensively revised. American Honda recommends reviewing the entire bulletin.

BACKGROUND

For vehicles with SCI compressed natural gas (CNG) fuel tanks, Honda is no longer replacing the fuel tank and solenoid valve altogether. If you replace the fuel tank solenoid valve, you must now install the original fuel tank.

All SCI aluminum fuel tanks are eligible for fuel tank solenoid replacement.

This service bulletin does not apply to Lincoln Composite fuel tanks, which must still be replaced as a remanufactured assembly. (Refer to service bulletin 01-005, CNG Fuel Tank Assembly Exchange Program.) Check the fuel tank label to confirm that the tank is from SCI.

REPAIR POLICY

Repairs on CNG fuel tank assemblies may require the installation of a new CNG fuel tank solenoid valve assembly.

PARTS INFORMATION

NOTE: To help clarify where new parts are used in the REPAIR PROCEDURE, the new part is listed in the applicable repair step with a > symbol.

Front Upper Turn Clip (2 required):

P/N 91561-SJD-003

Fuel Line Connector O-Ring (1/4 in. Port Side)
(2 required):

P/N 91066-S1G-A01

Fuel Line Connector O-Ring (3/8 in. Port Side):

P/N 91066-S1G-B01

Fuel Line Connector O-Ring (1/4 in.)(5 required):

P/N 91067-S1G-A01

Fuel Line Connector O-Ring (3/8 in.)(2 required):

P/N 91067-S1G-B01

Fuel Tank Solenoid Valve O-Ring:

P/N 17574-PDN-A01

NOTE: The fuel tank solenoid valve should be replaced by a Honda-certified natural gas dealer.

REQUIRED MATERIALS

Contact / Brake Cleaner: P/N 08700-9201

Nitrogen Bottle 240 cu ft (filled to 1,500 psi):
(commercially available)

PAG Oil: P/N 38897-P13-A01AH

Plastic Wire Tie: (commercially available)

Snoop Liquid Leak Detector:

(order from swagelok.com)

TOOL INFORMATION

CNG Tank Valve Replacement Kit: T/N

HONCNGKIT Kit contains these items:

Knurled Threaded Handle
Mini Gator Clamp
Molykote 55 grease
Negative/Positive Gator Clamp
Pin Spanner
Receptacle Gauge
Steel Braided Line
Yellow Paint Marker
Ground Wire
Manual Override Vent Tool
Vent Tube

Available for loan from the Honda Tool and Equipment Program at **888-424-6857**.

Vernier Caliper: (commercially available)

WARRANTY CLAIM INFORMATION

The normal warranty applies.

OP#	Description	FRT
3101S4	Remove and install the CNG fuel tank.	5.6
A	Replace CNG fuel tank solenoid valve.	1.0

Failed Part: 16750-RNE-A01

Defect Code: 03217

Symptom Code: 09001

Skill Level: Repair Technician
(Honda NGV Certified)

DIAGNOSIS

NOTE: You must be a Honda NGV-Certified Technician to do the fuel tank solenoid valve inspection or replacement work.

Follow the normal troubleshooting procedures found in the service information. If your troubleshooting leads you to suspect the solenoid valve assembly is faulty, go to REPAIR PROCEDURE.

REPAIR PROCEDURE

⚠ WARNING

Compressed natural gas is flammable and highly explosive. You could be killed or seriously injured if leaking natural gas is ignited.

Stop the engine, and keep heat, sparks and flames away.

Safety glasses need to be worn during these operations.

When venting fuel, follow local regulations concerning venting natural gas. Consult your local fire and environmental authorities for specific regulations. This procedure should be done outside, in a well ventilated area, or in a properly equipped NGV shop.

Check for a gas leak if there is an odor coming from the vehicle. Compressed natural gas can only be smelled, not seen.

The following service information procedures have been used in full or in part within this service bulletin. For more detail on these procedures, and torque specifications for some components, refer to the applicable service information.

- Fuel Pressure Relieving
- Fuel Tank Removal and Installation
- Fuel Joint Block Removal and Installation
- Rear Floor Undercover Removal and Installation
- Rear Floor Upper Crossmember Gusset Removal and Installation
- C-Pillar Trim Removal and Installation
- Rear Seat Belt Removal and Installation
- Rear Seat-back Removal and Installation
- Rear Floor Undercover Removal and Installation

Relieve the Fuel Tank Pressure

Vent the fuel pressure from the fuel tank with the CNG Vent Tool set. Refer to the Fuel Pressure Relieving procedure in the service information.

NOTE:

- Using the tank venting tool to relieve tank pressure makes the solenoid valve unusable, and it must be replaced with a new valve.
- Do not use the fuel stem to relieve pressure on the fuel receptacle line. If the fuel stem is removed, it must be replaced with a new one.

Remove the Fuel Tank Assembly from the Vehicle

1. Remove the fuel tank assembly from the vehicle as described in the applicable service information.
2. Position the four rubber blocks from the CNG tank valve replacement kit under the fuel tank frame and side rail. The joint block should be suspended above the ground.

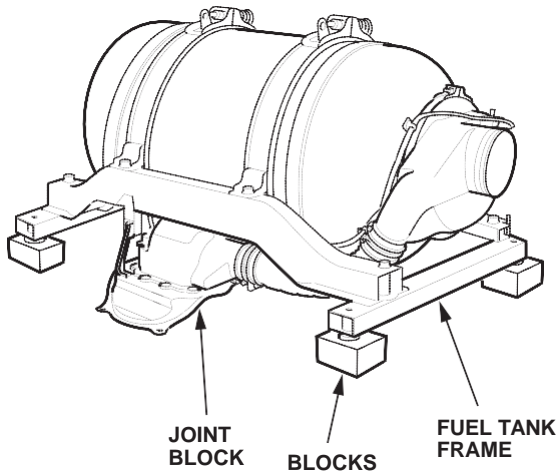

3. Use the large plastic wire tie to support the fuel joint block lines up to the frame. Make sure the joint block bracket is attached. Leave the wire tie in place until the lines are attached to the new solenoid valve.

NOTE: Do not overtighten the wire tie. This will cause pressure on the fuel lines and may cause problems aligning them to the new fuel tank valve.

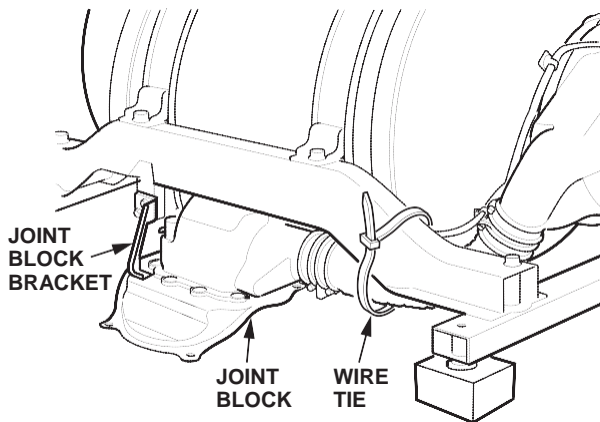

Remove the Tank Solenoid Valve

1. Loosen the large seal boot clamp. Pull the clamp and the vent boot aside far enough to be able to disconnect the 2-pin connector from the tank solenoid valve pigtail harness.

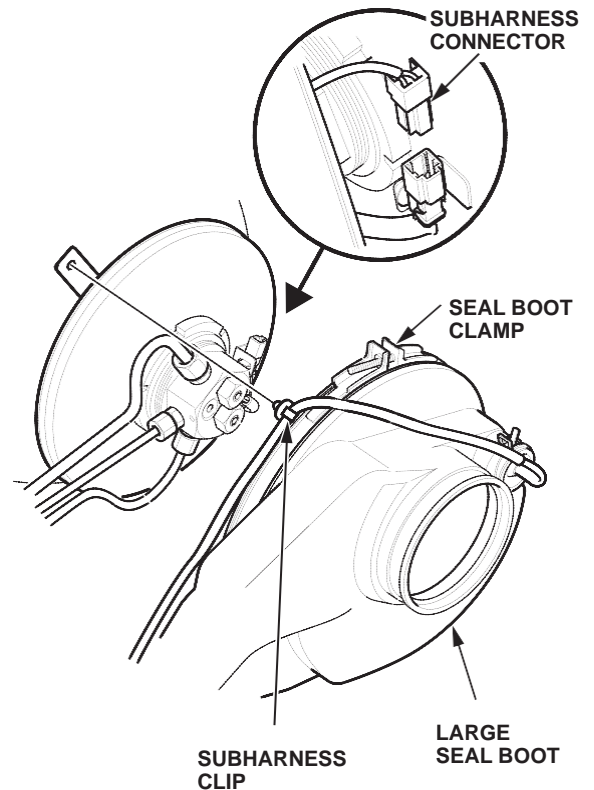

2. Fold back the seal boot to access the fuel lines.
NOTE: Use an elastic cord to hold the seal boot out of the way.

3. Loosen and remove the three fuel line nuts from the connector fittings. Remove the O-rings. Support the line connector on the valve with a wrench while loosening the line nut.
NOTE: Always use two wrenches when removing or installing the fuel line nuts.

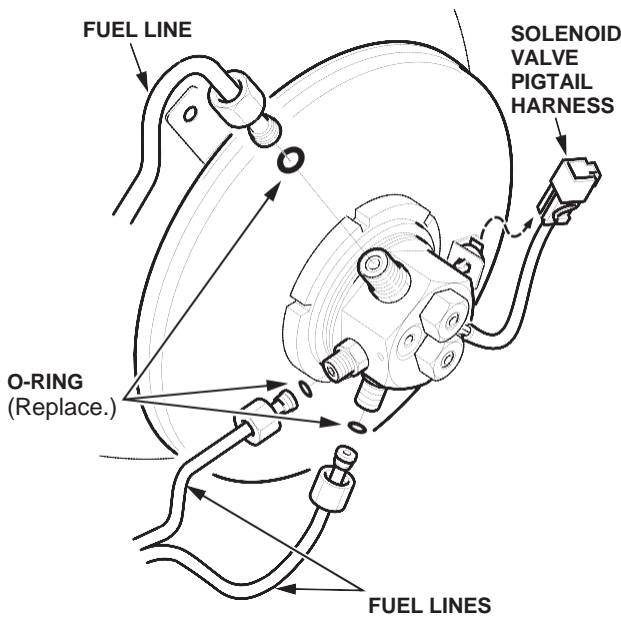

4. Disconnect the solenoid valve pigtail harness from the backing plate clip.
5. Gently pull the fuel lines back slightly, so you can remove the fuel line connectors.
NOTE: Be careful not to bend the fuel lines because they will not align properly if bent.

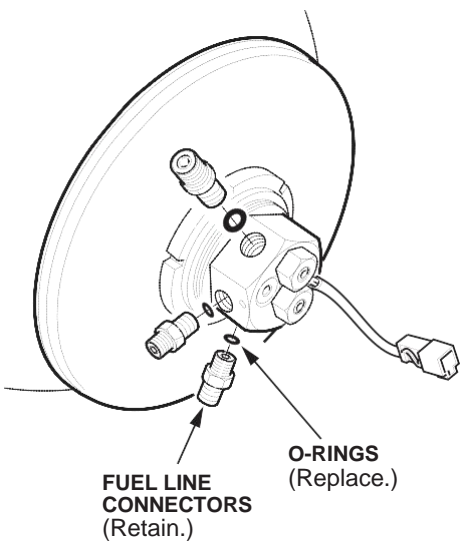

6. Note the position of the line connectors. Remove the three fuel line connectors.
NOTE: There are two smaller fittings. The one with the shorter threads goes into the middle position of the solenoid valve for the pressure relief valve.

7. Coil the pigtail harness on the end of the solenoid valve, then position the 2.5-inch socket over it, making sure the pigtail fits inside the socket.

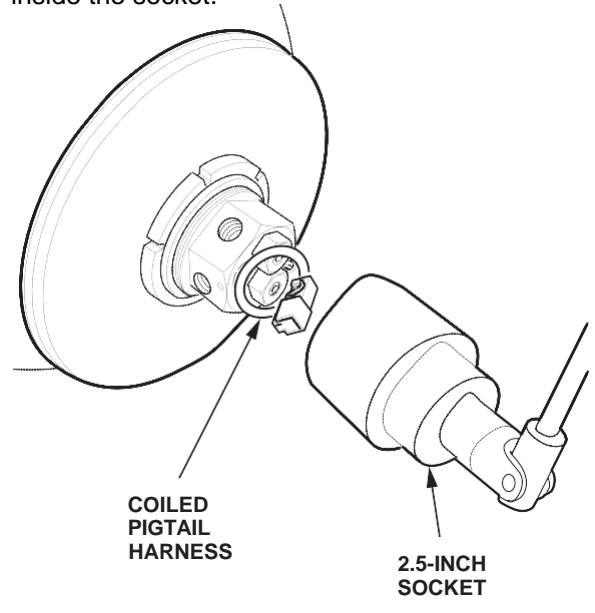

- Use the breaker bar supplied in the kit to loosen the solenoid valve.

⚠ WARNING
If the valve does not turn easily, the tank has pressure in it. Stop and do the tank venting procedure again. Do not proceed until there is no pressure in the tank and the valve turns easily.

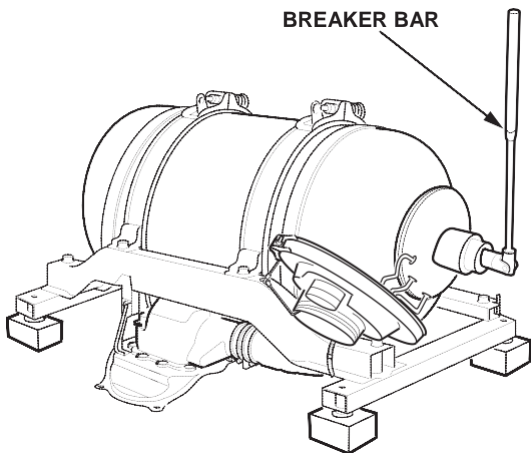

- Remove the solenoid valve by hand, and remove the O-ring.

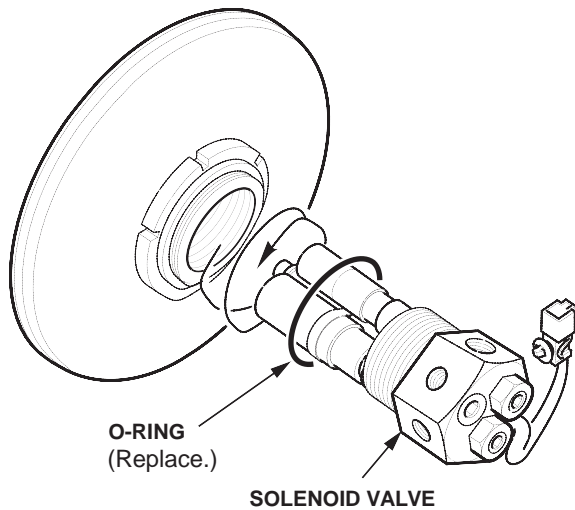

- Install the fuel tank stand support tool and the threaded tipping handle from the kit. With the help of an assistant, stand the tank on its end and allow it to drain for **20 minutes**. Place a clean and empty drain pan underneath the tank to catch any liquid as proof of contaminated CNG.

NOTE: If any liquid is found in the tank, replace both filters. Any water in the fuel tank indicates fuel contamination, and warranty consideration would not apply. Discuss your findings with your DPSM or Tech Line.

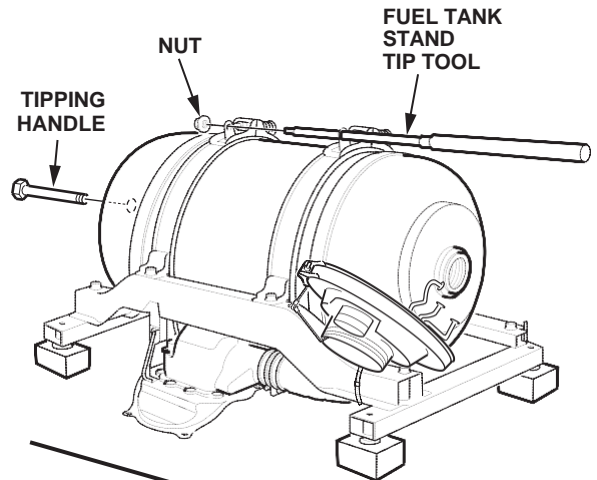

- Return the tank to the horizontal position.

Evaluate the New Replacement Solenoid Valve Condition Before Installing

1. Visually inspect the fuel tank solenoid valve for damage to the threaded area, the O-ring seat area, the wiring, and the connector.
> Fuel Tank Solenoid Valve

Inspect wiring.

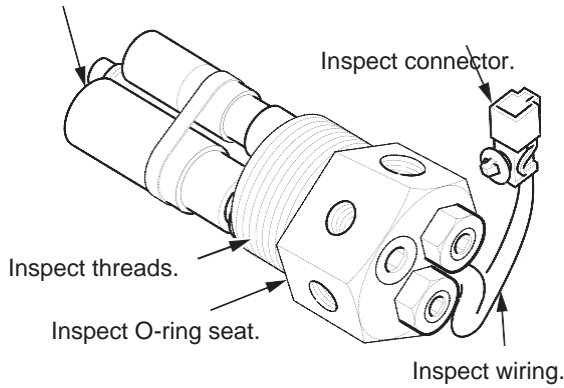

2. Connect the solenoid valve test harness from the kit to the solenoid valve 2-pin connector.
3. Using a DVOM, test the resistance of the new solenoid valve. It should be **18 to 21 ohms**.
 - If the solenoid valve is within specification, go to step 4.
 - If the solenoid valve is not within specification, obtain a new solenoid valve and test again.

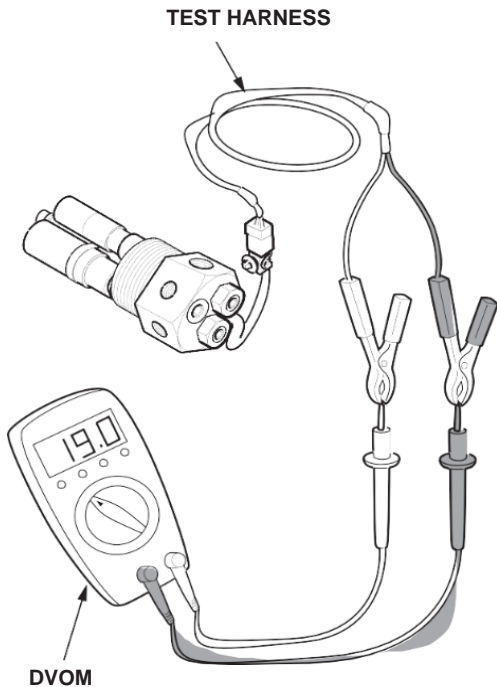

4. Momentarily connect the test harness to an automobile battery or booster pack, and electrically activate the solenoid valve.
 - If the solenoid valve works properly and you can see the solenoid plunger operate, go to step 5.
 - If the solenoid valve does not work properly, obtain a new solenoid valve and retest again.
After confirming proper operation, the valve is ready for installation.

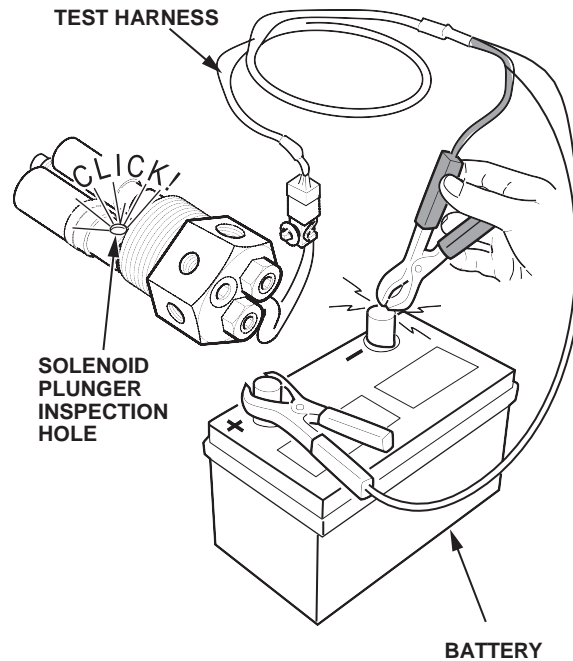

Install the Solenoid Valve

1. Use contact brake cleaner to clean the solenoid valve sealing surfaces on the valve and the tank.

NOTE: Make sure there are no rag or paper towel fibers left on any sealing surfaces.

2. Lubricate the new O-ring using only Molykote 55 grease included with the CNG valve replacement kit, and install the O-ring on the replacement solenoid valve.

NOTE: Use only Molykote 55 grease for this process. Do not use any other type of grease or lubricant.

> Fuel Tank Solenoid Valve O-Ring

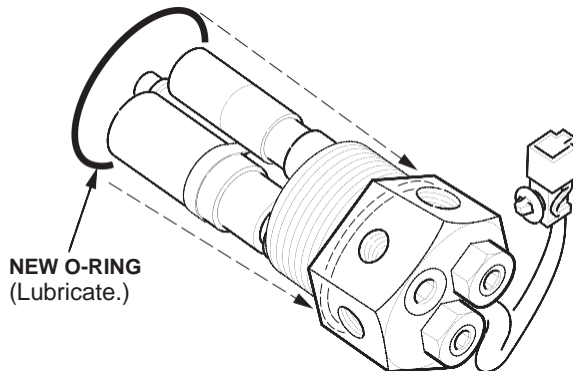

3. Hand-thread the solenoid valve into the tank, making sure the O-ring seats properly in its groove.

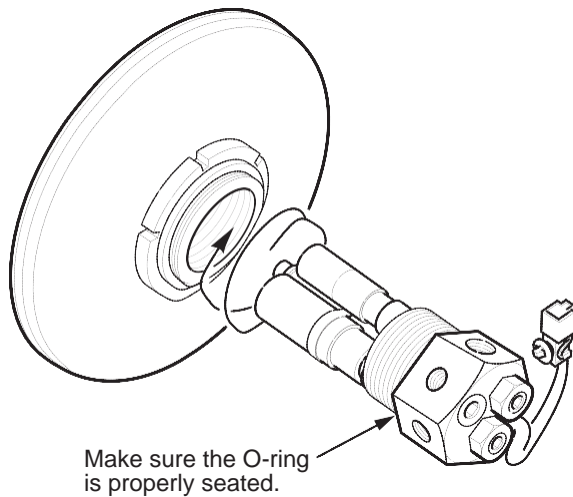

4. Coil the pigtail harness on the end of the solenoid valve, then position the 2.5-inch socket over it, making sure the pigtail fits inside the socket.

5. Set the torque wrench from the kit to **339 N·m (250 lb-ft)**, and torque the solenoid valve while an assistant holds down the side of the tank frame.

NOTE: Be careful not to bend the fuel lines.

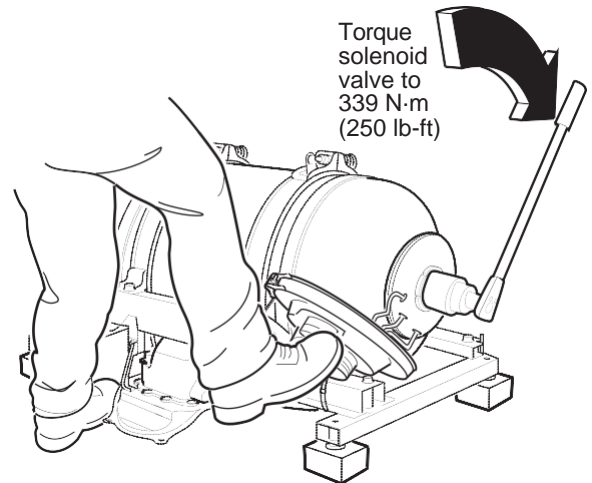

Check the Solenoid Valve Assembly for Leaks

NOTE: This leak check is a very important process done with nitrogen, a non-flammable gas. This eliminates the possibility of any fire danger from a leak between the tank and the new solenoid valve.

1. Install the blue leak check adapter fitting from the kit in the solenoid valve's receptacle port, and make sure the O-ring is installed. Torque the leak check adapter to **8 N·m (20 in-lb)**.

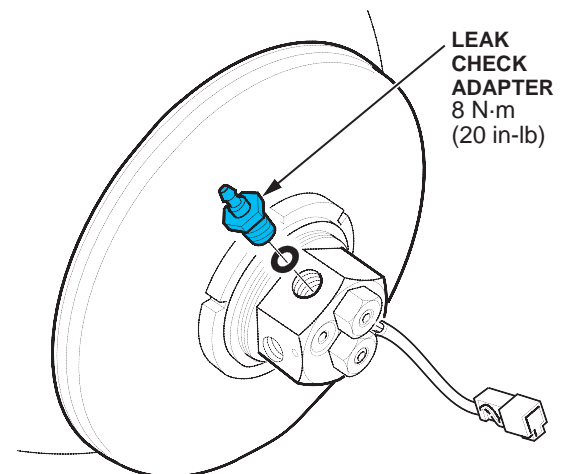

2. Install the nitrogen gas regulator supplied in the kit to the gas cylinder, and make sure the regulator key is unscrewed most of the way without removing it.

NOTE: Always wear safety glasses when working with pressure.

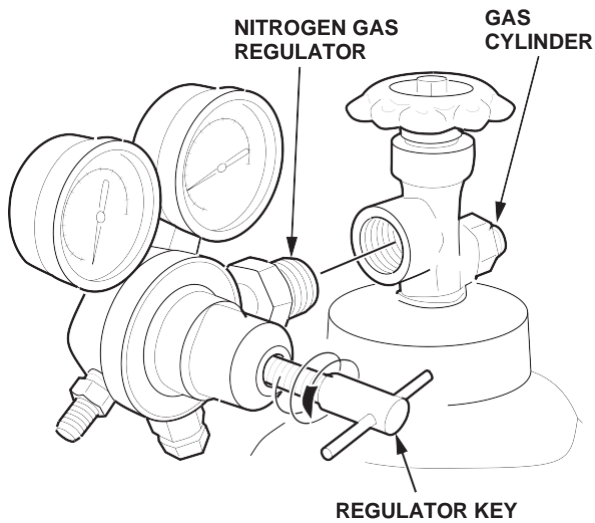

3. Connect the high pressure hose from the kit to the solenoid valve adapter and the gas regulator. Make sure the nitrogen tank is safely supported.

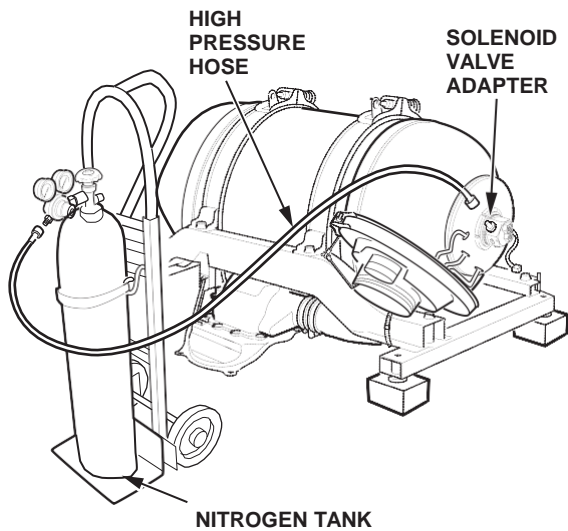

4. Open the main nitrogen cylinder valve number 1 as follows:

- Turn the regulator key number 2 clockwise to set the regulator to **400 PSI**.
- When the hissing stops, the tank is fully pressurized.

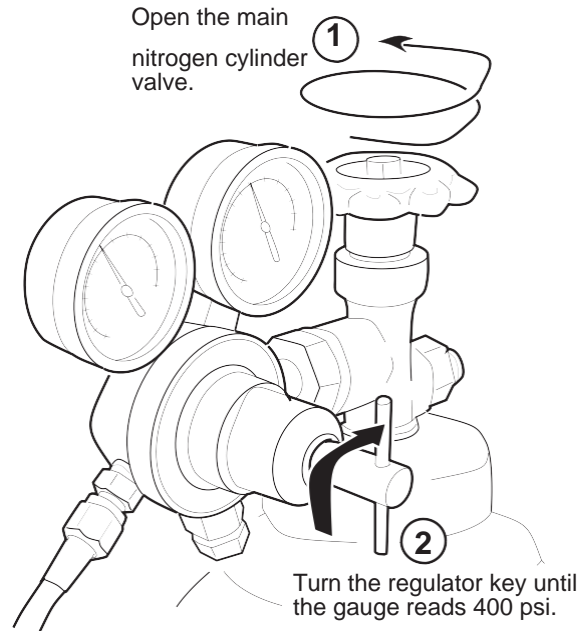

5. To check the solenoid valve O-ring for leaks, apply Snoop Liquid Leak Detector at the base of the solenoid valve. Check for bubbles around the O-ring seal. Use only Snoop Liquid Leak Detector because the nitrogen will not be detected by an electronic detector.
 - If there are no bubbles, go to step 7.
 - If there are bubbles, go to step 6.

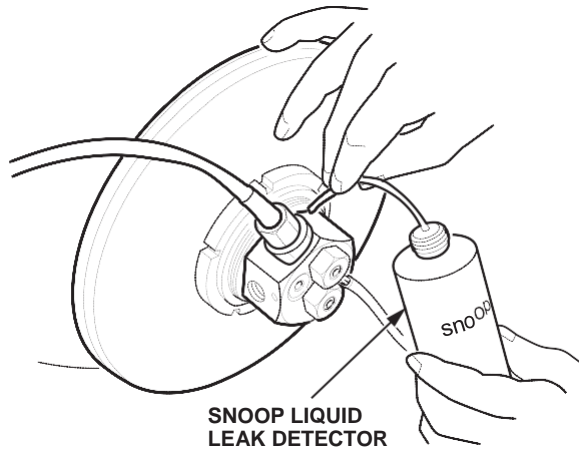

6. Call Tech Line for a procedure to release the nitrogen from the fuel tank without damaging it, then remove the solenoid valve. Check the sealing surfaces for debris, clean as needed, then do the following:
 - Check the sealing surface of the valve. If it is damaged, replace the valve and the O-ring.
 - Replace the O-ring with a new one.
 - Install the solenoid valve, then repeat steps 3 thru 5 to check for leaks.
7. If no leaks are found, close the nitrogen cylinder valve, loosen the regulator key, and slowly loosen the hose fitting at the fuel tank adapter to bleed off pressure in the hose. Only a small amount of gas should be released when breaking the seal on the hose.
 - If gas continues to vent, the solenoid check valve is defective. Remove and replace the solenoid valve and O-ring with a new one, then repeat the leak check procedure.
 - If nitrogen pressure does not leak continuously when the line is cracked open, remove the high pressure hose and the adapter fitting from the solenoid valve.

NOTE: The nitrogen will remain in the tank.

8. Install new O-rings on the three connectors. First apply tape over the connector threads to keep from scratching the O-rings while installing them. After installation, remove the tape, and lubricate the O-rings with PAG oil.
 - > Fuel Line Connector O-Ring (1/4 in. Port Side) (2)
 - > Fuel Line Connector O-Ring (3/8 in. Port Side)

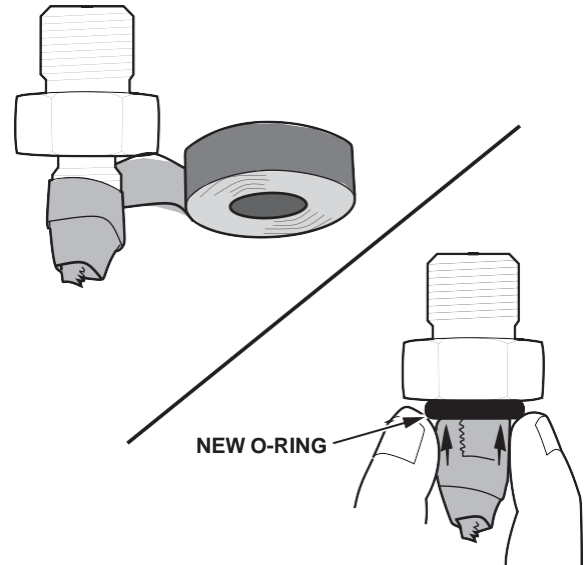

9. Install the three different connectors finger-tight in the correct port.

NOTE: Each connector is different. Make sure the correct connector is installed in the proper port.

- The large fuel line connector is installed in the large port.
- The pressure relief device is the same diameter as the small fuel line connector, but it is **shorter**. Make sure this connector is installed in the port shown.
- The small fuel line connector is the same diameter but **longer** than the pressure relief device. Make sure this connector is installed in the port shown.

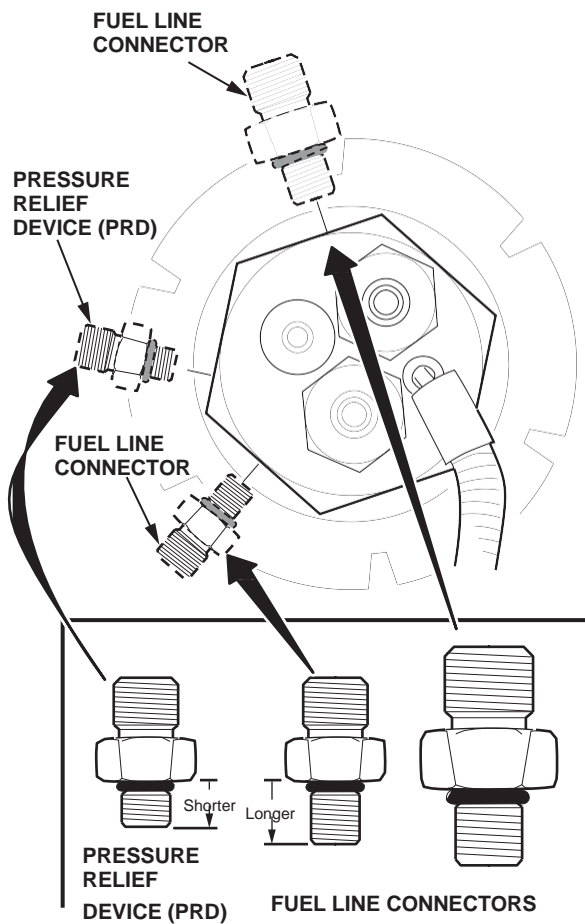

10. Install the three main fuel line connectors by making sure the tank is on its side, then, using a 5/8 inch crowfoot wrench on the smaller fittings and a deep socket on the large fitting, torque the fittings to these specifications:

- Small connectors: **20 N•m (15 lb-ft)**
- Large connector: **34 N•m (25 lb-ft)**

NOTE: Do not place O-rings on the outside of the connectors yet.

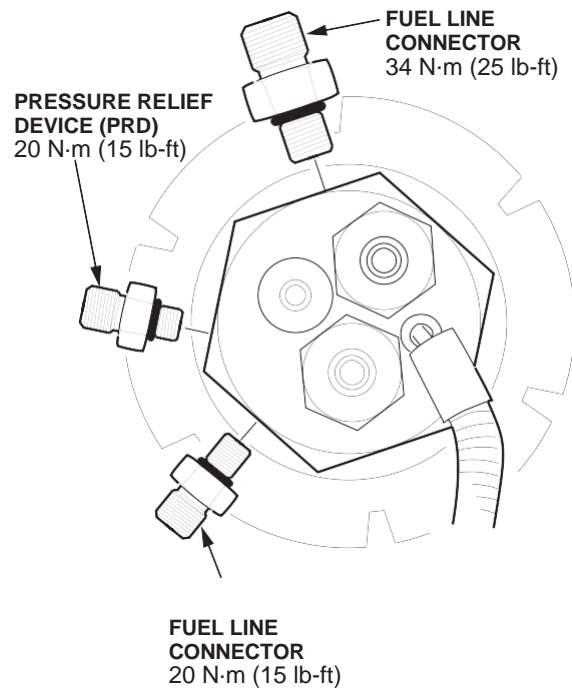

Align and Connect the Fuel Lines

NOTE: Alignment of the fuel lines is important. When installing a new fuel tank solenoid valve, the alignment will change.

1. Place a piece of masking tape on both tank bands near the spring retaining bolt assemblies.

NOTE: Installation of the new solenoid valve will change the alignment of the lines to the tank valve. Alignment of the lines to the valve is a critical step.

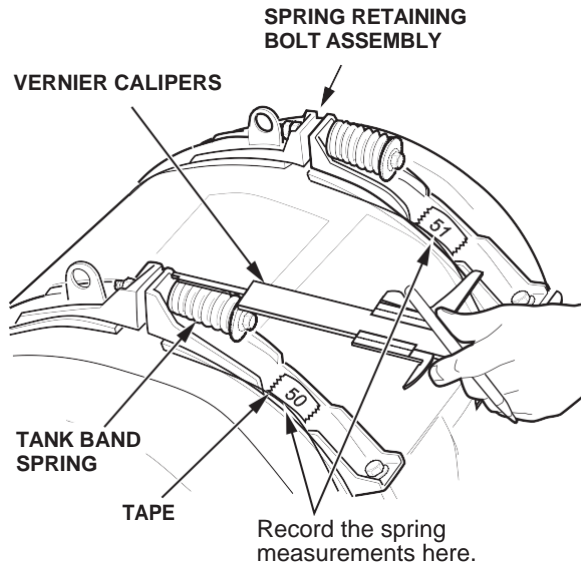

2. Measure both of the tank band spring lengths using a Vernier caliper. Record the measurement on the piece of tape that was placed on the tank band. You will need this later for assembly.
3. Loosen and remove the tank band spring retaining bolts.

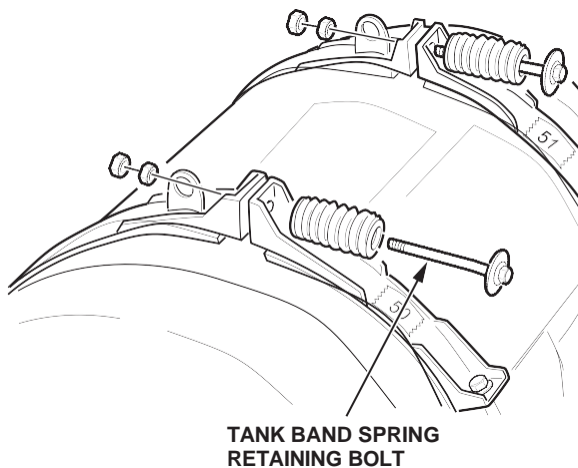

4. With the help of another assistant, carefully rotate the tank assembly as needed until the three fuel line flanges align flush with the line connector position (hold the nut back to see).

NOTE: The fuel tank may be stuck to the rubber cushions on the tension bands. Rock or lift the tank slightly to free it if needed.

Fuel line flanges misaligned. Rotate the tank.

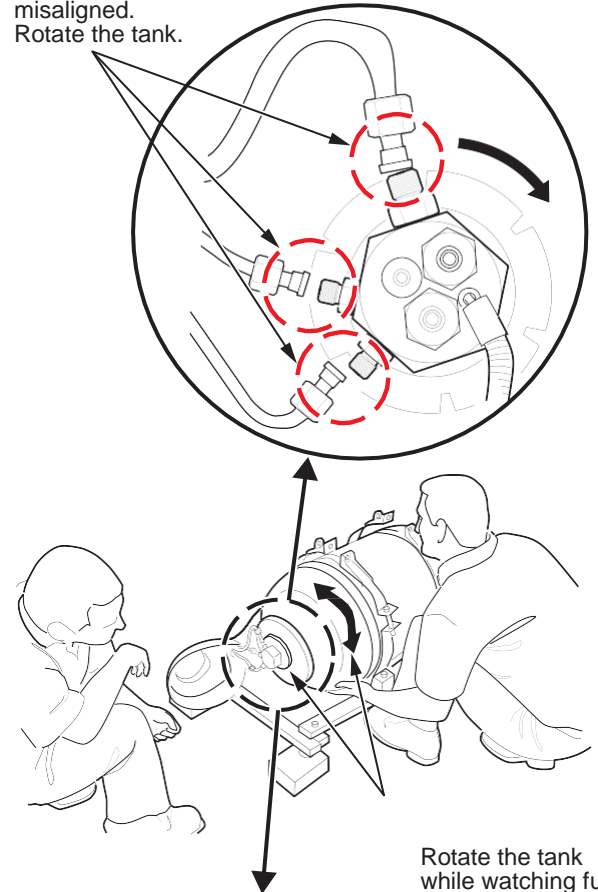

Rotate the tank while watching fuel line flange alignment.

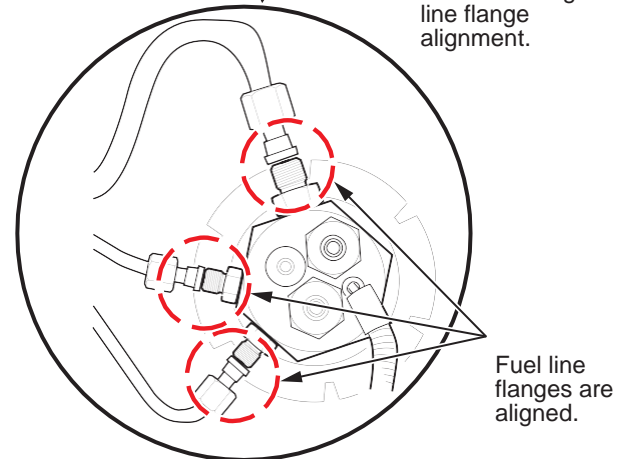

5. Lubricate the three O-rings with PAG oil, then install them on the connectors.
 - > Fuel Line Connector O-Ring (1/4 in.)(2)
 - > Fuel Line Connector O-Ring (3/8 in.)
6. While holding the fuel line tight against the fitting, first, hand-tighten the nut, then torque the line nuts to make sure the O-ring does not get misaligned and damaged. Torque to these specifications:
 - Small connectors: **27 N•m (20 lb-ft)**
 - Large connector: **47 N•m (35 lb-ft)**
7. Use a backup wrench on the connector fitting when tightening.

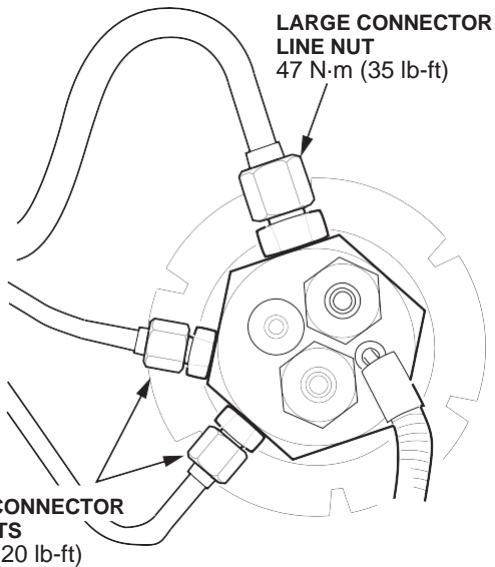

8. Make sure the tank does not shift when installing the tank band spring retaining bolt assemblies. Tighten them until the spring length is the same as previously recorded.

NOTE: Make sure the new alignment is correct before tightening the tank bands.

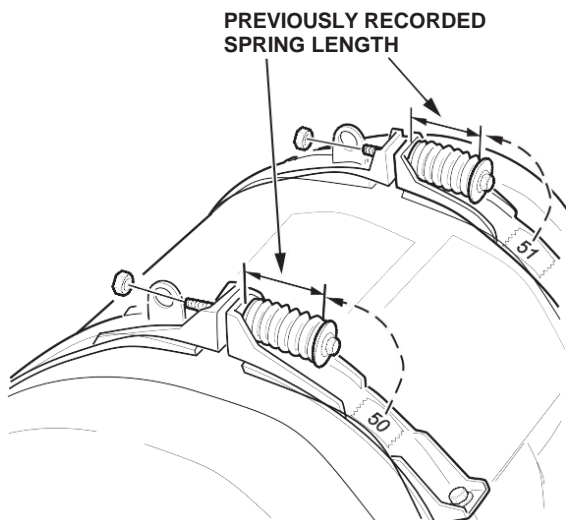

9. Make sure the vertical lines on the tank align with the tank bands.

NOTE: After the new solenoid valve is installed, if the marks are rotated to the rear, align them with the tank bands in the rear, then make new marks on the side of the tank that will face the trunk opening.

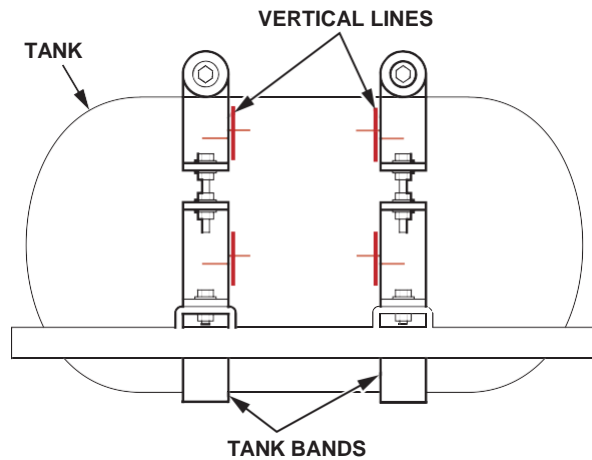

10. Install and torque the spring retaining bolt lock nuts to **38 N•m (28 lb-ft)**.

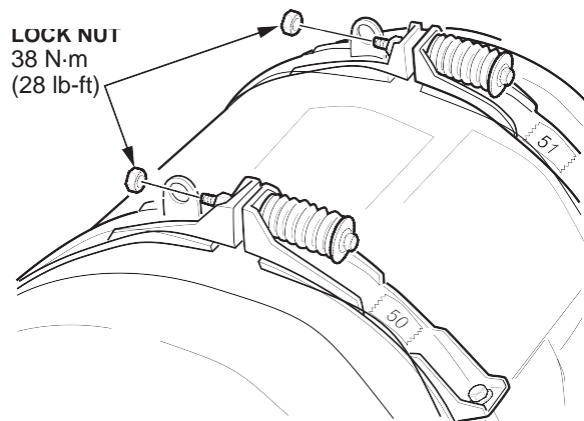

- Remove the old horizontal paint markings from the tank only, (not from the tank bands) using contact brake cleaner.

NOTE: Use the cleaner sparingly to avoid damaging the fuel tank paint.

HORIZONTAL LINES

Note how they shifted when the tank bands were retightened.

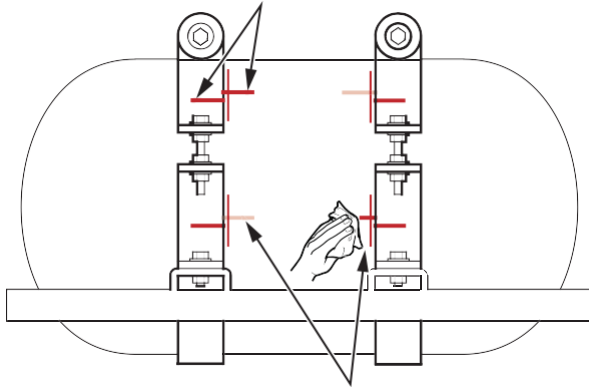

Remove the horizontal marks from the tank only.

- Mark the fuel tank horizontal lines using the yellow paint marker supplied in the kit. Trace over the original lines that remain on the tank bands, and paint the lines about **1.5 to 2 inches** long on the tank. It is important to mark accurate lines, as these new lines will be used to evaluate proper tank positioning. The lines you paint may go over the label, but this is not a concern.

NOTE: If the paint marks are on the outside edge of the band (not shown, this may be seen on late model tanks) continue to mark the new position on the outside of the band.

View them from the trunk opening side.

Remark the horizontal lines.

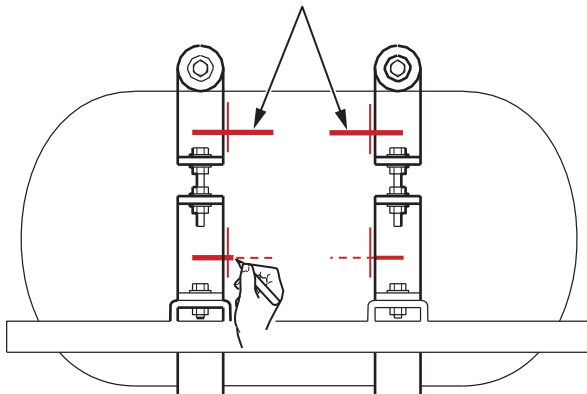

Assemble the Seal Boot and Backing Plate

- Using the spanner from the kit, loosen the seal boot backing plate collar, and rotate the backing plate to its original position.

NOTE: Use the solenoid valve wire harness clip as a guide to positioning the backing plate. Rotate the plate until the harness clip lines up with the tab.

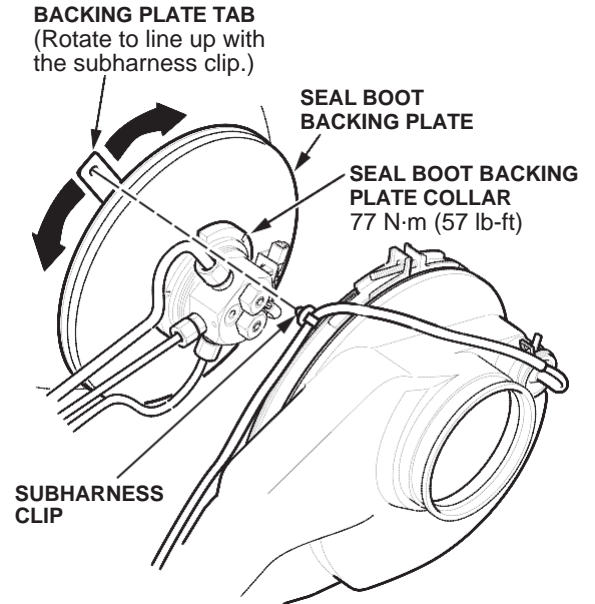

- Tighten the seal boot backing plate collar, using the spanner from the kit, to **77 N·m (57 lb-ft)**.

NOTE: Make sure the backing plate stays in position. It will tend to move as you torque the collar.

3. Connect the wire harness to the backing plate tab.

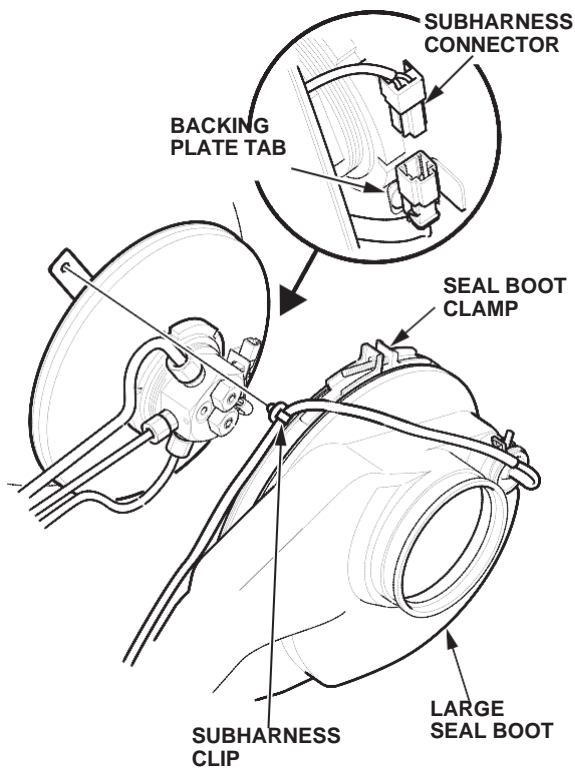

4. Connect the 2-pin solenoid subharness connector to the wire harness on the tab.

Fuel Tank Assembly Installation

NOTE: The fuel tank will have a final leak check when fully filled with CNG before the complete assembly.

1. With the help of an assistant, install the fuel tank assembly in the vehicle, and torque the fuel tank frame bolts to **38 N•m (28 lb-ft)**.
2. Loosely install the two top bolts to the joint block plate.

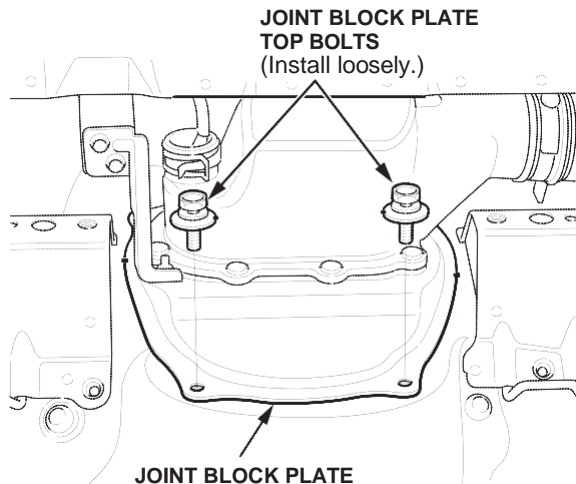

3. Connect the fuel tank wire harness to the body harness.

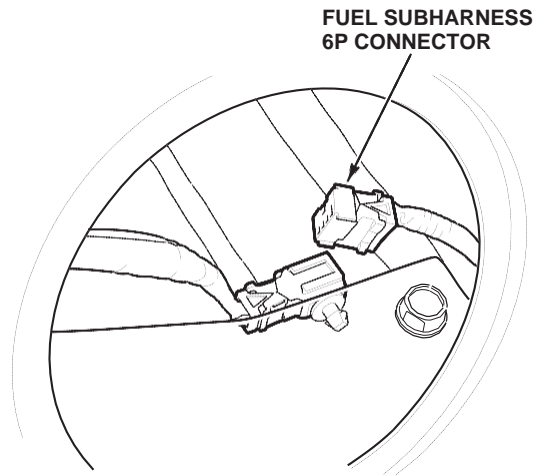

4. Raise the vehicle. Install the two bottom bolts to the joint block, plate and tighten them. Make sure to tighten the two top bolts when you return to the interior.

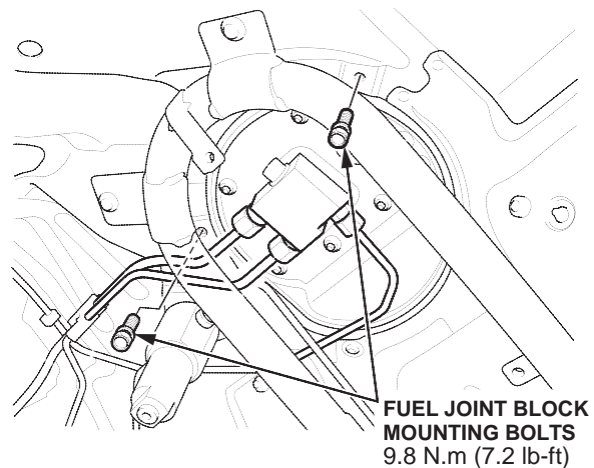

- Lubricate the new O-rings with PAG oil, install them, then connect the fuel lines to the joint block under the vehicle. Follow the service information procedure for torquing the lines.

> Fuel Line Connector O-Ring (1/4 in.)(2)

> Fuel Line Connector O-Ring (3/8 in.)

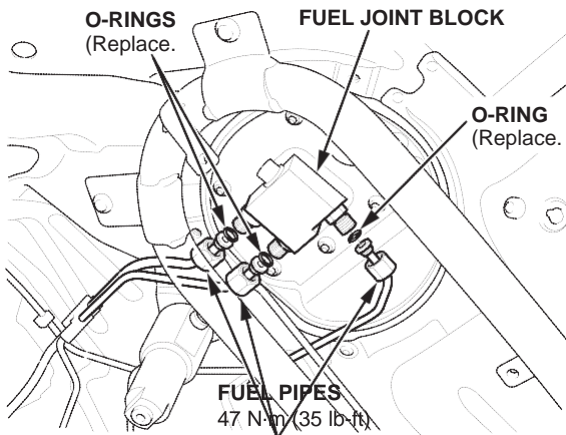

- Install a new O-ring to the fuel connection at the fuel filter that was removed when the CNG fuel tank was vented. Torque the fuel connection to **31 N•m (23 lb-ft)**.

> Fuel Line Connector O-Ring (1/4 in.)

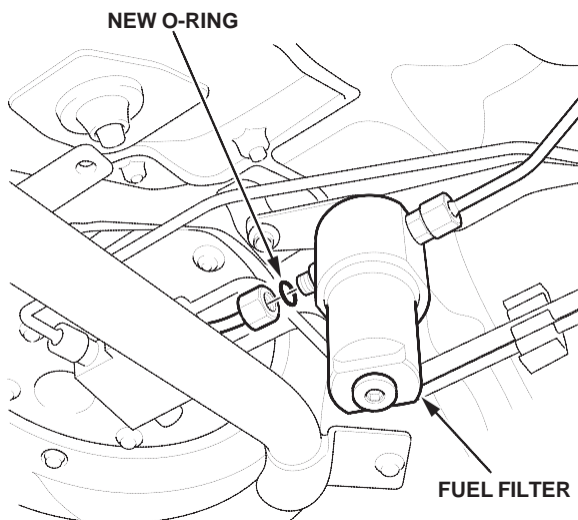

- Close the manual valve. Transport the vehicle to a fast-fill fueling station, and fill the tank completely to **3,600 PSI**.

NOTE: Leave the manual valve closed during the filling procedure and when transporting the vehicle.

- Open the manual valve.

- Run the engine. Using the service information procedure and only Snoop Liquid Leak Detector, check for leaks at the tank solenoid O-ring, lines, joint block fittings, and all fittings and connectors removed during the repair process. Repair any leaks found.

- Completely assemble the seal boot, and tighten the large seal boot clamp.

- Install all of the remaining parts according to the applicable service information.

- Enter the audio unit presets, and set the clock.

- Test-drive the vehicle.