



Technical Service Bulletin

SUBJECT:		No:	TSB-20-42A-001
CORRECTION TO TIGHTENING TORQUE OF TAILGATE LATCH BOLT - SMR		DATE:	February 2020
		MODEL:	2019-20 Outlander Sport/RVR
CIRCULATE TO:	<input type="checkbox"/> GENERAL MANAGER	<input checked="" type="checkbox"/> PARTS MANAGER	<input checked="" type="checkbox"/> TECHNICIAN
<input checked="" type="checkbox"/> SERVICE ADVISOR	<input checked="" type="checkbox"/> SERVICE MANAGER	<input type="checkbox"/> WARRANTY PROCESSOR	<input type="checkbox"/> SALES MANAGER

PURPOSE

This TSB updates the Body section of the affected Service Manuals to correct the tightening torque of the fixing bolt for the tailgate latch, and to distinguish the different torques for the 2 types of bolts for 2019 model year vehicles.

AFFECTED VEHICLES

- 2019 - 2020 Outlander Sport/RVR

AFFECTED SERVICE MANUALS

- 2019 - 2020 Outlander Sport/RVR Service Manual, Group 42A-Body



Please make the indicated changes to the 2019 Outlander Sport/RVR Service Manual, Group 42A-Body -> Liftgate -> Liftgate Handle and Latch -> Removal and Installation.

NOTE: For 2019 MY vehicles, there are 2 types of bolts depending on production date.

- **Production to end of April 2019: Bolt with washer**
- **Production from May 2019: Flange Bolt**

**BODY
 LIFTGATE**

**LIFTGATE HANDLE AND LATCH
 REMOVAL AND INSTALLATION**

M1424001700921

Post-installation operation

- Liftgate alignment (Refer to P.42A-166.)

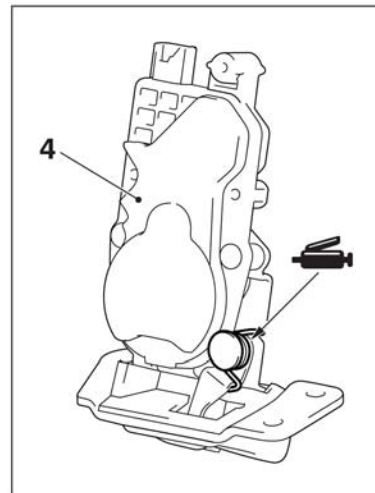
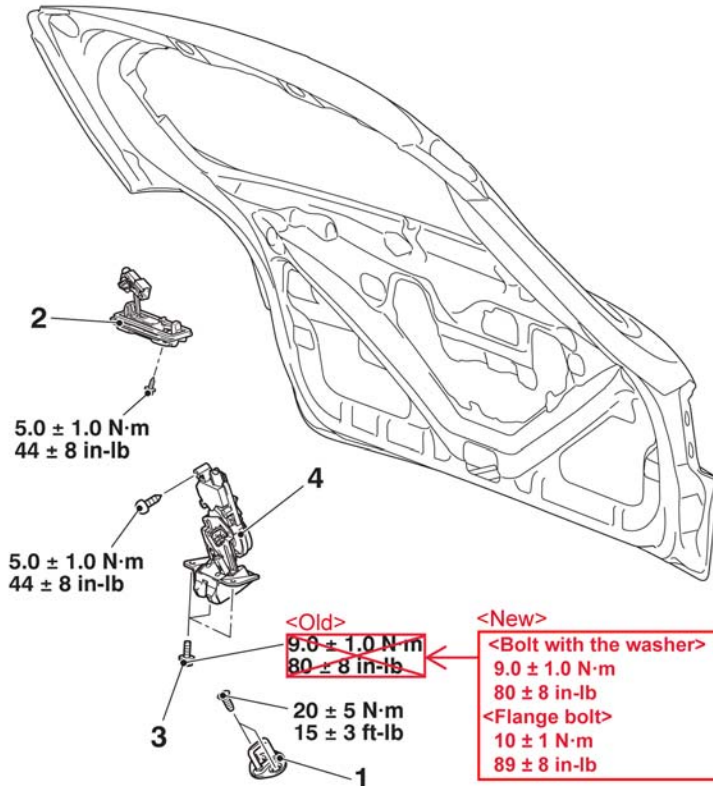

AC904459AB

- Striker removal steps**
- Rear end trim (Refer to GROUP 52A – Interior trims .)
- >>A<< 1. Striker
- Liftgate lock release handle removal steps**
- Liftgate trim (Refer to GROUP 52A – Liftgate trims .)

<<A>>

- Liftgate lock release handle removal steps (Continued)**
- Rear wiper motor assembly (Refer to GROUP 51 -Rear Wiper and Washer .)
2. Liftgate lock release handle
- Liftgate latch removal steps**
- Liftgate trim (Refer to GROUP 52A – Liftgate trims .)
3. Ground bolt
- >>B<< 4. Liftgate latch assembly

Please make the indicated changes to the 2020 Outlander Sport/RVR Service Manual, Group 42A-Body -> Liftgate -> Liftgate Handle and Latch -> Removal and Installation.

**BODY
 LIFTGATE**

**LIFTGATE HANDLE AND LATCH
 REMOVAL AND INSTALLATION**

M1424001700921

- Post-installation operation**
- Liftgate alignment (Refer to P.42A-166.)

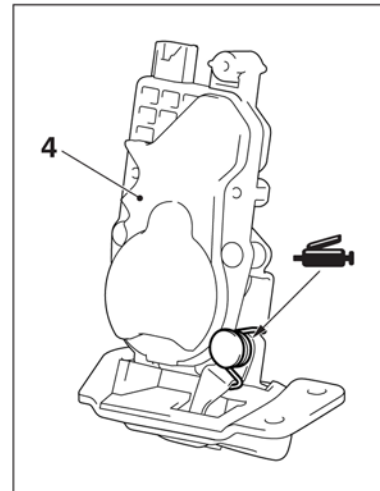
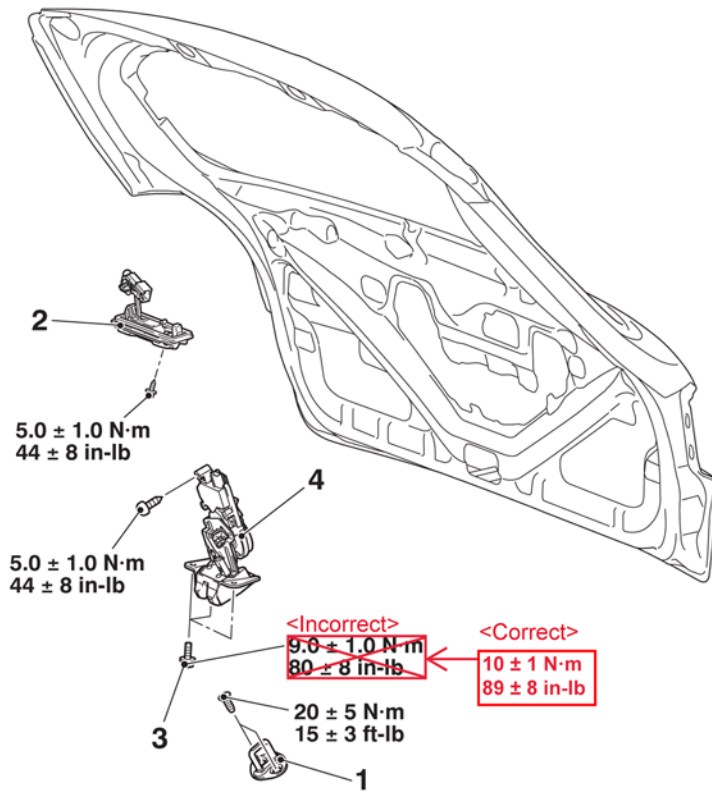

AC904459AB

- Striker removal steps**
- Rear end trim (Refer to GROUP 52A – Interior trims .)
- >>A<< 1. Striker
- Liftgate lock release handle removal steps**
- Liftgate trim (Refer to GROUP 52A – Liftgate trims .)

<<A>>

- Liftgate lock release handle removal steps (Continued)**
- Rear wiper motor assembly (Refer to GROUP 51 -Rear Wiper and Washer .)
2. Liftgate lock release handle
- Liftgate latch removal steps**
- Liftgate trim (Refer to GROUP 52A – Liftgate trims .)
3. Ground bolt
- >>B<< 4. Liftgate latch assembly