



Service Bulletin

Bulletin No.: 20-NA-047

Date: March, 2020

TECHNICAL

Subject: Front or Rear Crankshaft Oil Leak, Malfunction Indicator Lamp (MIL) Illuminated - DTC P1101 Set

This bulletin replaces PIP5417C. Please discard PIP5417C.

Brand:	Model:	Model Year:		VIN:		Engine:	Transmission:
		from	to	from	to		
Buick	Encore	2016	2019			1.4L (RPO LE2)	
Chevrolet	Cruze	2016	2019			1.4L (RPO LE2)	
	Equinox	2018	2020			1.5L (RPO LYX)	
	Malibu	2016	2020			1.5L (RPO Lfv)	
	Trax	2019	2019			1.4L (RPO LE2)	
	Volt	2016	2019			1.5L (RPO L3A)	
GMC	Terrain	2018	2020			1.5L (RPO LYX)	

Involved Region or Country	North America, China, Thailand, GM Korea, Middle East, Israel, Europe, Brazil, Chile, Colombia, Peru, South Africa
Condition	Some customers may comment on one or more of the following conditions: <ul style="list-style-type: none"> • Oil Leak • MIL illuminated Some technicians may find DTC P1101 (Intake Air Flow System Performance) set in the Engine Control Module (ECM).
Cause	This condition may be caused by higher than normal crankcase pressures, due to a plugged positive crankcase ventilation (PCV) orifice.
Correction	While performing Strategy Based Diagnostics for P1101 or engine oil leaks on the listed engines, testing for excessively positive crankcase pressures is necessary for root cause isolation.

Crankshaft Pressure Test

Use the Evaporative Emissions System Tester (EEST) to record the crankcase pressure.

Refer to the pictures below for connection of the EEST at the engine oil dipstick port and related readings.



3416804

EEST hose adaptor



4573240

EEST Gauge at 0 reading

Note: The connection must be made with the engine off. The engine is then started and the pressure reading is recorded.



4573243

Normal crankcase pressure readings for the L3A, LE2, LFV and LYX are between -1 & -5 inches of water in park at hot idle.

- If the crankcase pressure is in the proper range, follow Strategy Based Diagnostics for engine oil leaks and/or P1101 per SI.
- If the crankcase pressure is excessively positive, above 0 inches of water (0 inches of HG / vacuum), then a positive crankcase pressure concern exists requiring further diagnostics.

Inspect for any air induction restrictions in the front air intake duct to air cleaner housing or in the air cleaner housing (nesting materials, water intrusion or ice blockage, kinked PCV tube or modifications to the air induction system).

Note: Refer to Service Bulletin 18-NA-171 or 19-NA-122 for conditions caused by cracked pistons. These are usually accompanied with a P0300 and they can cause higher crankcase pressures.

Camshaft Cover Inspection, Cleaning and Orifice Replacement

Remove the camshaft cover and remove the PCV orifice and inspect for blockage. Replace the orifice as necessary along with the camshaft cover gaskets. Make sure the camshaft cover does not have any blockages in the PCV passages.



5513764

If diagnosing for oil leaks and/or DTC P1101 with no engine oil leaks and excessive positive crankcase pressure exists, an obstructed PCV orifice (1) would be suspect requiring a PCV orifice replacement.

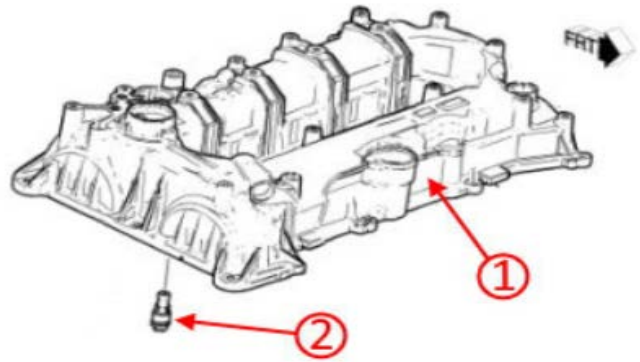

5519694

1. Remove the camshaft cover (1). Refer to *Camshaft Cover Replacement* in SI.
2. Remove the PCV orifice (2) and inspect for blockage.
3. Verify the camshaft cover does not have any blockages in the PCV passages.
4. Replace the orifice as necessary along with the camshaft cover gaskets.
5. Install the camshaft cover.

Parts Information

Causal Part	Vehicle	Description	Part Number	Qty
X	All	ORIFICE, PCV VLV	12641875	1
N/A	All	GASKET, CM/SHF POSN ACTR SOL VLV	12636176	1
N/A	All	GASKET, CM/SHF CVR (OUTER)	12636177	1
N/A	All	GASKET, CM/SHF CVR (INNER)	12636384	1
N/A	Encore/Cruze/Malibu/Trax/Equinox/Terrain	GASKET, VAC PUMP	12665421	1
N/A	Encore/Cruze/Malibu/Trax/Equinox/Terrain	SEAL, VAC PUMP	12668429	1
N/A	Equinox/Terrain	GASKET, CM/SHF POSN ACTR SOL VLV	12676587	1

Warranty Information

For vehicles repaired under the Base Emission Warranty coverage (Code E), use the following labor operation. Reference the Applicable Warranties section of Investigate Vehicle History (IVH) for coverage information.

Labor Operation	Description	Labor Time
4087348*	Crankshaft Pressure Test	0.3 hr
Add	Camshaft Cover Inspection, Cleaning and Orifice Replacement	2.0 hrs
*This is a unique Labor Operation for bulletin use only.		

Version	1
Modified	Released February 28, 2020

