

- ATTENTION:**
- GENERAL MANAGER
  - PARTS MANAGER
  - CLAIMS PERSONNEL
  - SERVICE MANAGER

IMPORTANT - All Service Personnel Should Read and Initial in the boxes provided, right.

© 2019 Subaru of America, Inc. All rights reserved.



QUALITY DRIVEN® SERVICE

**SERVICE PROGRAM BULLETIN**

**APPLICABILITY:** 2015-2018MY Forester 2.0L Turbo  
2016-2018MY WRX 2.0L Turbo

**NUMBER:** WUK-96R

**DATE:** 12/05/19

**SUBJECT:** DIT Exhaust Pipe Front (EPF) Nut Torque

**REVISED:** 03/26/20

**INTRODUCTION:**

Subaru of America, Inc. (Subaru) is initiating a service campaign for certain 2015-2018 Forester 2.0L Turbo and 2016-2018 WRX models which may experience a loosening of the front exhaust pipe nuts. On certain affected vehicles, the six (6) front exhaust pipe (EPF) nuts at the cylinder heads may not have been tightened sufficiently due to variations in production. As a result, these nuts may become loose during use and cause exhaust leakage. A leak occurring at the front exhaust pipe may result in deterioration of emission performance. As a result, affected vehicle may fail to meet emission levels certified by the EPA and/or California ARB.

**AFFECTED VEHICLES:**

Vehicles included in this service campaign are 2015-2018 Forester XT and 2016-2018 WRX. This recall will affect approximately **93,796** vehicles. Coverage for all affected vehicles must be confirmed by using the Vehicle Coverage Inquiry function on [subarunet.com](http://subarunet.com). This information is now available.

Model Year	Carline	Affected Production Dates
2015-2018	Forester XT	5/11/2015 - 3/20/2018
2016-2018	WRX	5/09/2015 - 10/04/2017

**DESCRIPTION OF THE REPAIR:**

Subaru retailers will inspect the 6 nuts securing the front exhaust pipe to the cylinder heads on all affected vehicles. If any of the 6 nuts are found to be loose or lost and / or exhaust gas leakage is identified at either of the connections to the cylinder heads, the retailer should replace the front exhaust pipe.

**CAUTION: VEHICLE SERVICING PERFORMED BY UNTRAINED PERSONS COULD RESULT IN SERIOUS INJURY TO THOSE PERSONS OR TO OTHERS.**

Subaru Service Bulletins are intended for use by professional technicians ONLY. They are written to inform those technicians of conditions that may occur in some vehicles, or to provide information that could assist in the proper servicing of the vehicle. Properly trained technicians have the equipment, tools, safety instructions, and know-how to do the job correctly and safely. If a condition is described, DO NOT assume that this Service Bulletin applies to your vehicle, or that your vehicle will have that condition.

**Subaru of America, Inc. is ISO 14001 Compliant**

ISO 14001 is the international standard for excellence in Environmental Management Systems. Please recycle or dispose of automotive products in a manner that is friendly to our environment and in accordance with all local, state and federal laws and regulations.

*Continued...*

## RETAILER RESPONSIBILITY:

Retailers are to promptly perform this repair on all affected vehicles in their inventory. Additionally, whenever a vehicle subject to this service program is taken into inventory or in for service, necessary steps should be taken to ensure the update has been made before selling or releasing the vehicle.

## OWNER NOTIFICATION:

Subaru is in the process of acquiring registration data and will notify affected vehicle owners by first class mail by the end of March. Retailers will be advised when owner notification occurs.

## RETAILER AFFECTED VIN LISTS:

Each Subaru retailer will receive an affected VIN list from their Zone Office. Vehicles will be assigned to retailers as follows:

- Original vehicle owners are assigned to the original selling retailer when their current address is within a 100-mile radius of that retailer.
- If the original selling retailer is inactive, the VIN has been assigned to the nearest active retailer.
- For any new owners or when original owners live more than 100 miles from the original selling retailer, the VIN has been assigned to the nearest active retailer.

**IMPORTANT:** Retailer affected VIN lists include information for vehicles affected by this service program. This information will enable retailers to follow up with owners of affected vehicles. The lists contain owners' names and phone numbers obtained from State Motor Vehicle Registration Records. The use of such motor vehicle registration data for any other purpose is unlawful. Accordingly, retailers are required to limit the use of these lists for the sole purpose of completing this service program.

## PART INFORMATION:

EPF Exhaust Gasket Kit, p.n. **X4460AA011**

### NOTES:

- This kit will only be required when the inspection procedure outlined below determines EPF replacement is necessary. The likelihood of a need to replace the EPF assembly is expected to be extremely low.
- If exhaust leakage is confirmed, peripheral (surrounding) parts (e.g. engine mount, oil level sensor / switch) may be damaged as a result. These parts will need to be ordered separately.



*Continued...*

## SERVICE PROCEDURE:

On certain vehicles, the six (6) nuts securing the front exhaust pipe (EPF) to the cylinder heads may not have been tightened sufficiently due to variations in production. As a result, these nuts may become loose during use resulting in exhaust leakage. Therefore, torque on these 6 nuts must be inspected on all affected vehicles. If any of the 6 nuts are found to be loose or lost and / or exhaust gas leakage is identified at either of the connections to the cylinder heads, the front exhaust pipe must be replaced.

Use the following Flow Chart below as an overview / guideline for performing this procedure. Step-by-step instructions are also provided below.

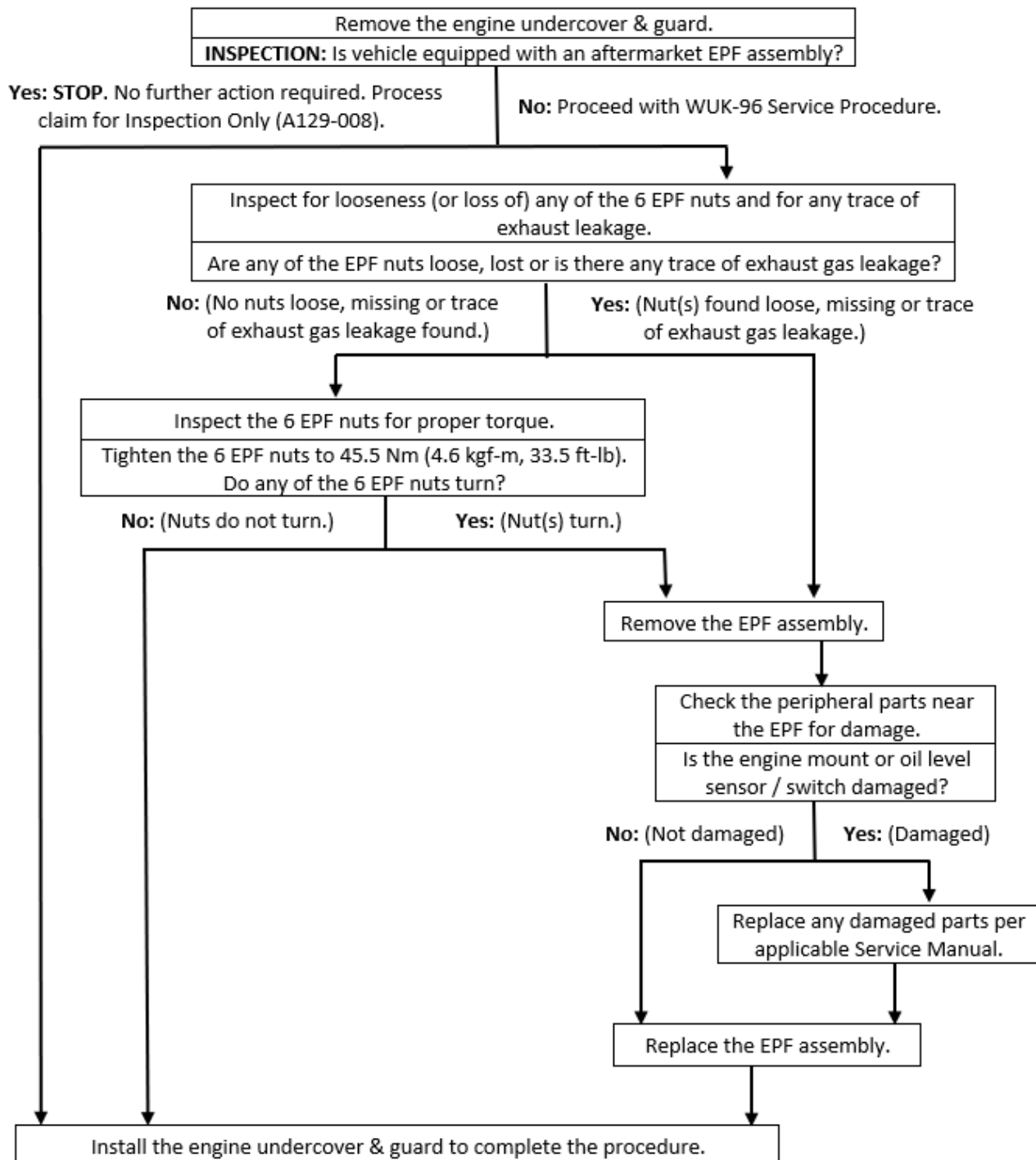

*Continued...*

### Helpful Hints for Technicians if EPF replacement is necessary:

- After draining the cooling system, ALWAYS replace the o-ring on the radiator petcock (a new one is included in the EPF parts kit).
- Be sure to remove (and re-install) the braided ground strap from the heat shield above the front exhaust pipe connection.
- The turbocharger stay bracket, main and sub cooling fans and the water pump pulley DO NOT need to be removed.
- When installing the new o-rings on the air flow meter, they both look the same but, they have different part numbers and two different locating tabs. The tab on the turbo outlet (charge) pipe o-ring is not centered. The tab's offset must be toward the turbocharger otherwise, it will distort as shown below. The other o-ring's tab is centered and can be installed in either way.



Locating Tab Is Offset  
(not centered).

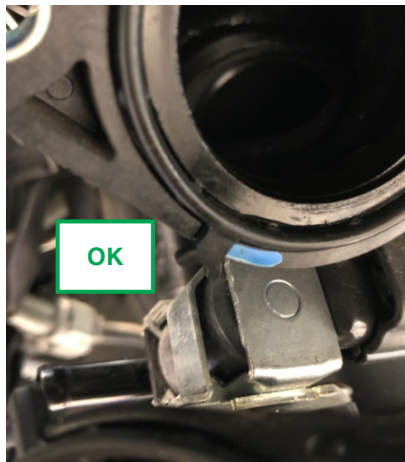

Locating Tab Is Installed  
Toward Turbo, O-Ring Is **OK**.

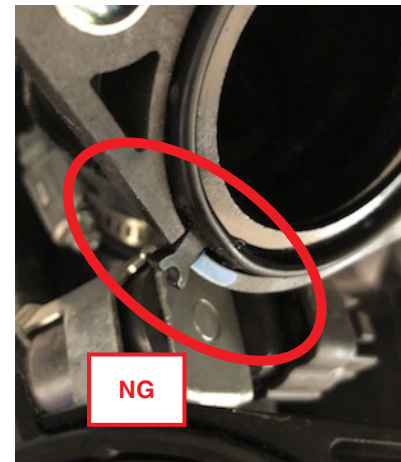

Tab Is Installed Toward Meter,  
O-Ring is Distorted.

- When reinstalling the Turbo / EPF assembly, only snug (do not tighten / torque) the 6 EPF flange nuts at the cylinder heads. Install the 2- 14mm hex bolts for the turbocharger stay brackets, tighten / torque them to specification 33Nm (3.4 kgf-m, 24.3 ft. lbs.) FIRST then, proceed to torque the 6 EPF flange nuts to 45.5 Nm (4.6 kgf-m, 33.5 Ft. Lbs.) TWICE and IN THE ORDER SHOWN IN STEP 2 on pg. 5.
- Loosen the 10mm hex bolt in the center of the bottom EPF heat shield before reinstalling the turbocharger oil reservoir. This will make it easier to get the reservoir back into position. Also, put the 2 long 10mm hex bolts through the reservoir, hold them in place and put the new gasket on them as shown below. This makes the gasket installation much easier.
- To insure the cooling system has been completely refilled (with NEW coolant) and any remaining air pockets removed, the use of a vacuum refilling system is strongly recommended.

**IMPORTANT NOTE:** As stated at the top of the Flow Chart, if inspection reveals an after-market EPF assembly (a.k.a. performance exhaust header), **STOP**. Reinstall the undercover and proceed to the Claim Reimbursement and Entry Procedures section for IMPORTANT information on how to process the Inspection Only claim.



*Continued...*

**Step 1:** Remove the front under cover and guard. Inspect the following two areas carefully:

- Are any of the 6 EPF nuts shown in the figure below missing?
- Is there any trace of exhaust gas leakage (soot deposits) around the EPF mounting flanges at the cylinder heads? **IMPORTANT:** Always check for exhaust gas leakage even if all the EPF nuts are in place.

**REMINDER:** If after removing the engine undercover, inspection reveals an aftermarket EPF assembly (a.k.a. performance exhaust header), **STOP**. Reinstall the undercover and proceed to the Claim Reimbursement and Entry Procedures section for **IMPORTANT** information on how to process the Inspection Only claim.

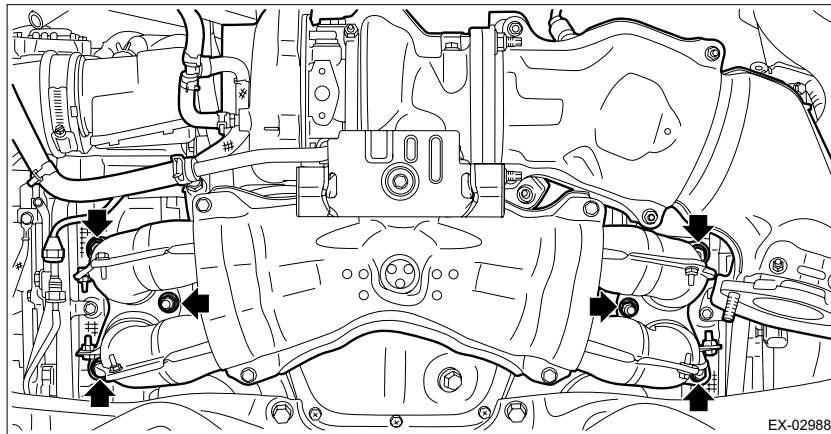

**NO** → When all 6 of the EPF nuts are in place or, if there is no trace of exhaust gas leakage, proceed to **Step 2:** and inspect the 6 EPF nuts for proper torque.

**YES** → When any of the 6 EPF nuts are missing or, if there is exhaust gas leakage: proceed to **Step 3:** and replace the EPF assembly.

**Step 2:** Tighten the 6 EPF nuts to 45.5 Nm (4.6 kgf-m, 33.5 ft-lb) in the order shown below to check if any of them turn.

**TIP:** Marking the edge of the flanged nuts and head pipe flange first with a scribe or similar tool will help determine if one or more of them move during this inspection.

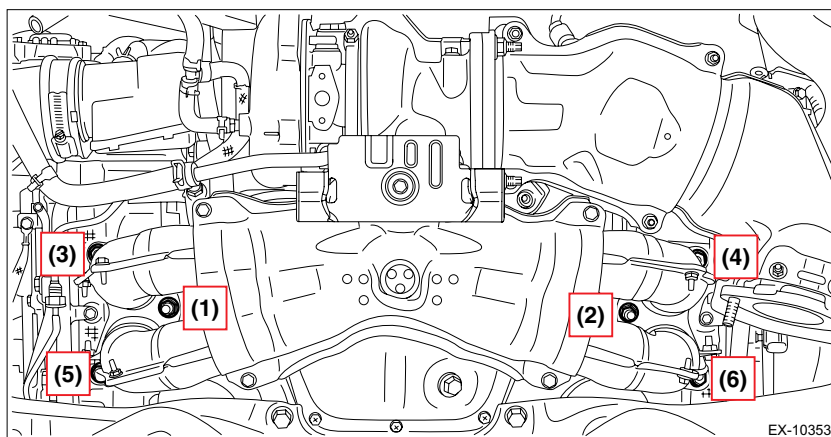

**NO** → If none of the 6 EPF nuts turn: reinstall the front engine under cover to complete the procedure.

**YES** → If any of the 6 EPF nuts turn: proceed to **Step 3:** and replace the EPF assembly.

*Continued...*

**Step 3:** When inspections during **Step 1)** or **Step 2)** dictate the EPF needs to be replaced, replace it following the procedure in the applicable Service Manual. During EPF replacement, inspect the peripheral parts (engine mount, oil level switch / harness, etc.) for any heat damage from leaking exhaust.

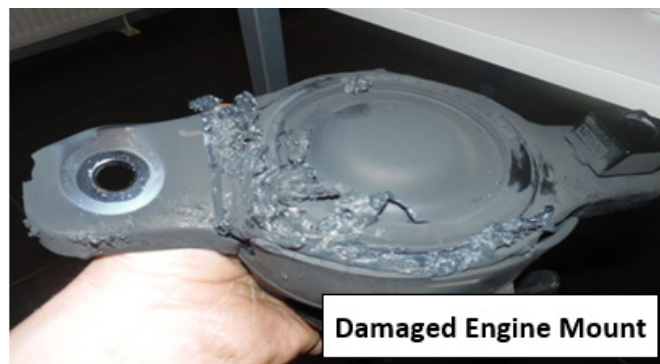

If none of the peripheral parts near the EPF are damaged, replace the EPF assembly to complete the procedure.



If any peripheral parts near the EPF are damaged, replace them as needed along with the EPF assembly following the procedures outlined in the applicable Service Manual.

**REMINDER:** When reinstalling the Turbo / EPF assembly, only snug (do not tighten / torque) the 6 EPF flange nuts at the cylinder heads. Install the 2- 14mm hex bolts for the turbocharger stay bracket, tighten / torque them to specification **FIRST** then, proceed to torque the 6 EPF flange nuts **TWICE** and **IN THE PROPER ORDER** as specified in the applicable Service Manual.

## CALIFORNIA “VEHICLE EMISSION RECALL - PROOF OF CORRECTION” CERTIFICATE

The California Air Resources Board and the Department of Motor Vehicles Registration/Recall Program requires that all emission related Recall/Campaign or Service Program repairs be completed before a vehicle registration is renewed. Please provide owners of vehicles registered in the state of California a completed “Vehicle Emission Recall - Proof of Correction” certificate. Vehicle owners should be advised to retain this certificate because the California Department of Motor Vehicles may require they provide proof this service program repair has been completed.

Additional certificates are available through normal parts ordering channels using part number MSA6P1301. Quantity 1 = 1 booklet of 50 certificates.

Vehicle Emission Recall - Proof of Correction				
License Number	Make	Year Model	Body Type	Vehicle Identification Number
Manufacturer Subaru of America, Inc.			Recall Number	
The above described vehicle has been repaired, modified and/or equipped with new emission control devices to meet applicable California Emission Control Laws				
Dealer's Name		Address, City, State and Zip		
Date	Dealership's Authorized Signature			
X				
Return this certificate to DMV only when required-otherwise retain for your records.				

*Continued...*

**SERVICE PROGRAM IDENTIFICATION LABEL:**

Type or print the necessary information on a Campaign Identification Label. The completed label should be attached to the vehicle’s upper radiator support. Additional labels are available through normal parts ordering channels. The part number is **MSA6P1302**, which comes as one sheet of 20 labels.

<b>SUBARU</b>	
Campaign Code	
<b>WUK-96</b>	
COMPLETED	
DIST./DEALER NO.	
SERIAL NO.	
<b>DO NOT REMOVE</b>	

Part Number	Applicability	Description	Order Quantity
MSA6P1302	All Models	Campaign Completion Labels (contains one sheet of 20 labels)	1

**CLAIM REIMBURSEMENT AND ENTRY PROCEDURES:**

Credit to perform this service campaign will be based on the submission of properly completed repair order information. Retailers may submit claims through Vehicle Claim Entry on [subarunet.com](http://subarunet.com).

Labor Description	Labor Operation #	Labor Time	Fail Code	Claim Type
EPF INSPECTION ONLY, A/MARKET EPF FOUND	A129-008	0.3	WUK-96	RC
EPF INSPECTION AND TORQUE CHECK (OK) ONLY	A129-018	0.4		
EPF INSPECTION AND REPLACE EPF ASSY.	A129-011	1.8		
EPF INSPECTION, REPL. EPF ASSY, ENGINE MOUNT AND / OR OIL LEVEL SENSOR SWITCH R&R	A129-013	2.9		

**IMPORTANT NOTE:** When processing an inspection only claim after identifying an aftermarket EPF, it is **STRONGLY RECOMMENDED** a Vehicle Modification / Damage / Aftermarket Product Report (see Section 17.8 of the Claims Policy and Procedures Manual) be completed and retained along with a photo for documentation purposes.

**IMPORTANT REMINDERS:**

- SOA strongly discourages the printing and/or local storage of service information as previously released information and electronic publications may be updated at any time.
- Always check for any open recalls or campaigns anytime a vehicle is in for servicing.
- Always refer to STIS for the latest service information before performing any repairs.