

WINDOWS

Purpose

This document outlines the procedure for replacing/installing a 2000 series window vented exit picture window handle.

NOTE: Images used in this document are for reference only when assembling, installing and/or operating this product. Actual appearance of provided and/or purchased parts and assemblies may differ.

Safety

Read and understand all instructions before installing or operating this product. Adhere to all safety labels.

CAUTION

The “CAUTION” symbol above is a sign that a safety risk is involved and may cause personal injury and/or product or property damage if not safely adhered to and within the parameters set forth in this manual.

CAUTION

Moving parts can pinch, crush or cut. Keep clear and use caution.

Procedure

1. Extend the window handle into the open position (Fig. 1A).
2. Remove the screen by pulling the red tab (Fig. 1B) away from the window. Pull the screen (Fig. 1C) up and out and set aside to reinstall.

NOTE: Take caution when removing the screws from the yoke bracket that the window does not slam back against the frame.

3. Locate the yoke bracket (Fig. 2A) and remove the two screws (Fig. 2B). Place the screws aside to reinstall.

Fig. 1

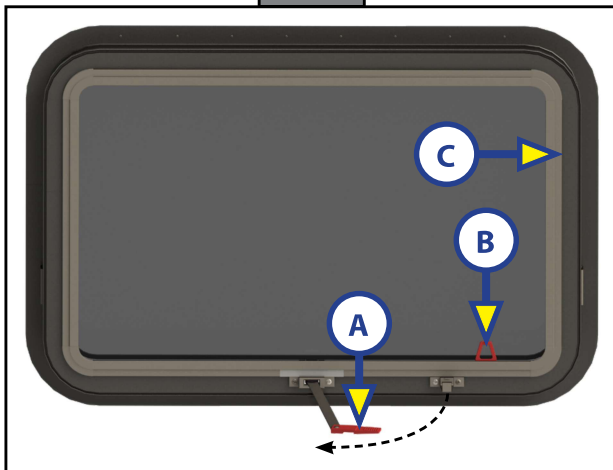
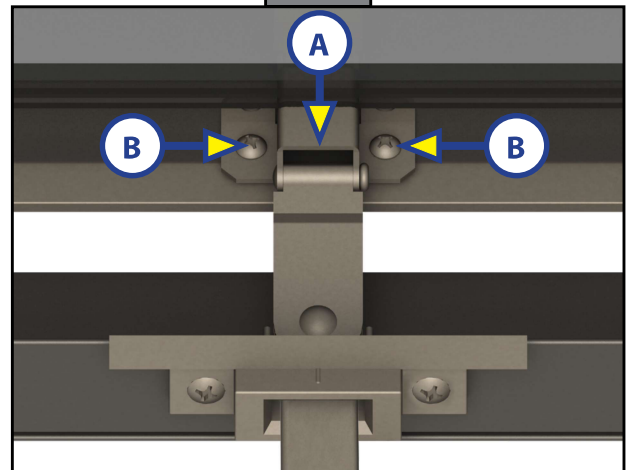
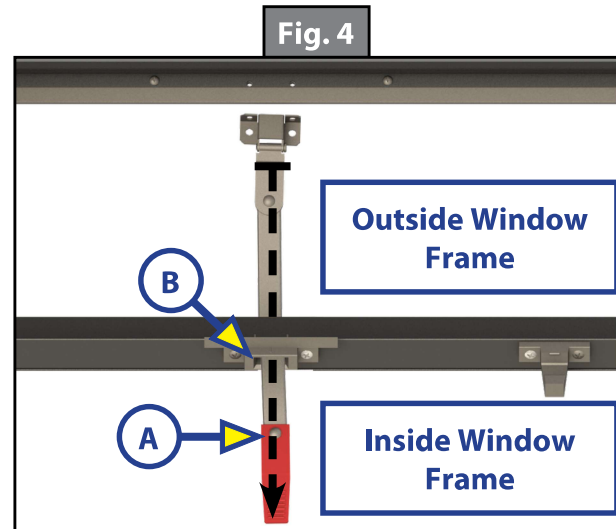
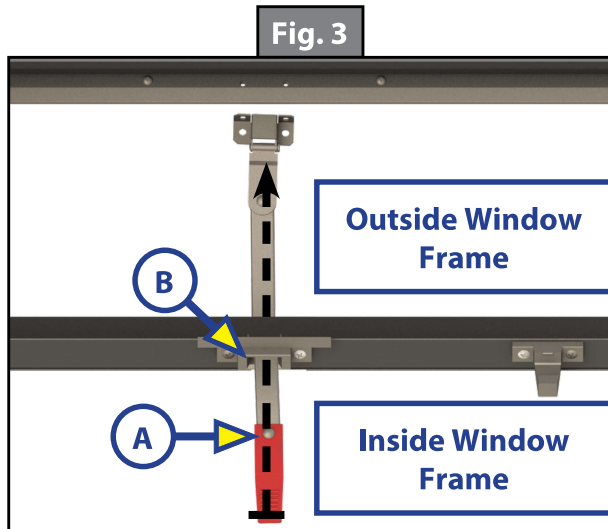

Fig. 2



WINDOWS

4. Slide the handle assembly (Fig. 3A) towards the outside of the unit, through the plastic support bracket (Fig. 3B).
5. Install the new handle assembly (Fig. 4A) in the opposite direction of step 4, sliding the handle assembly through the plastic support bracket (Fig. 4B) towards the inside of the unit.



6. Reinstall the previously removed screws (Fig. 2B) into the yoke bracket (Fig. 2A).
7. Reinstall the screen (Fig. 1C) into the window frame.
8. Close the window by moving the handle assembly (Fig. 5A) into closed and locked position (Fig. 5B).

Fig. 5

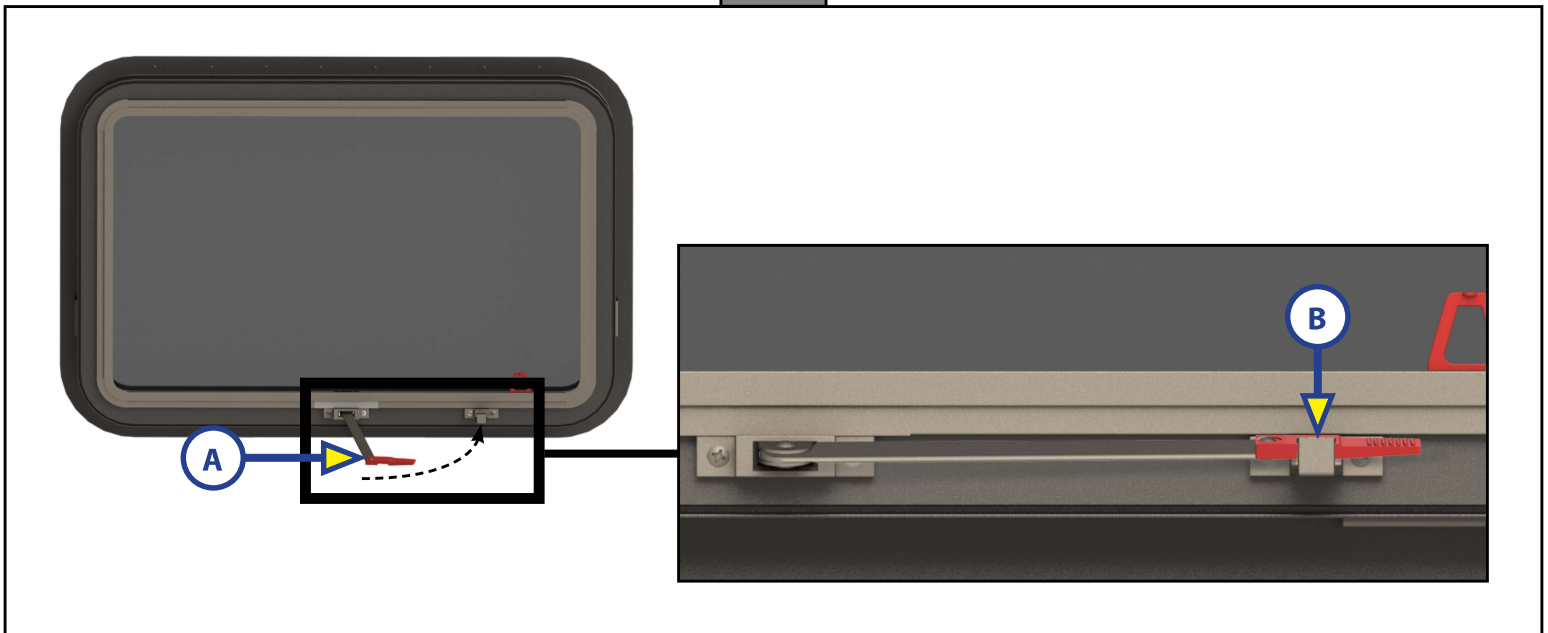

As a supplier of components to the RV industry, safety, education and customer satisfaction are our primary concerns. Should you have any questions, please do not hesitate to contact us at (574) 537-8900 or by email at customerservice@lci1.com. Self-help tips, technical documents, product videos and a training class schedule are available at lci1.com or by downloading the MyLCI app.