

H207NAS2
TECHNICAL BULLETIN
 01 APR 2020



© Jaguar Land Rover North America, LLC

NOTE: The information in Technical Bulletins is intended for use by trained, professional Technicians with the knowledge, tools, and equipment required to do the job properly and safely. It informs these Technicians of conditions that may occur on some vehicles, or provides information that could assist in proper vehicle service. The procedures should not be performed by 'do-it-yourselfers'. If you are not a Retailer, do not assume that a condition described affects your vehicle. Contact an authorized Jaguar service facility to determine whether this bulletin applies to a specific vehicle.

SECTION:

501-14

SUBJECT/CONCERN:

Service Action - Hood Latch And Hood Release Cable Renew

AFFECTED VEHICLE RANGE:

MODEL:	MODEL YEAR:	VIN:
I-PACE (X590)	2019-2020	F60001-F79532

MARKETS:

NORTH AMERICA

CONDITION SUMMARY:

SITUATION:

A potential issue has been identified on certain Jaguar vehicles within the listed Affected Vehicle Range where the customer may not be able to close the hood and/or unable to lock the vehicle due to the hood state reporting as 'open' with the 'Hood Open' warning displayed on the Instrument Cluster (IC).

ACTION:

Retailers are required to HOLD affected new vehicles that are within your control and refrain from releasing the vehicles for new vehicle sale pending completion of the procedure(s) detailed in this Technical Bulletin. Unsold vehicles should have this performed as part of the Pre-Delivery Inspection (PDI) process but must have it completed prior to vehicle handover to the customer.

Affected vehicles already in the hands of customers should be updated at the next available opportunity.

PARTS:**NOTES:**

- Order only the expected percentage demand of parts as identified.
- Use the Vehicle Identification Number (VIN) and the Electronic Parts Catalogue (EPC) to confirm part number(s) necessary to perform repairs.

DESCRIPTION	PART NUMBER	QUANTITY	EXPECTED PERCENTAGE DEMAND
Hood latch	T4K11208	1	100
Hood release cable	T4K12760	1	74

SPECIAL TOOLS:

Refer to TOPIx Workshop Manual/procedure(s) for any required special tools.

WARRANTY:

NOTE:

Use the Jaguar Land Rover claims submission system to make sure that a vehicle is eligible for this program prior to undertaking any rework action.

At the time of confirming a booking for vehicle repair, make sure that all open Recall and Service Actions are identified to make sure the correct parts are available and adequate workshop time is allocated for repairs to be completed at one visit.

Warranty claims must be submitted quoting the Program Code and the relevant Option Code; this will result in payment of the stated time. The SRO and parts information is included for information only. The Option Code(s) that allows for the drive in/drive out allowance may only be claimed if the vehicle is brought back into the workshop for this action alone to be undertaken.

Repair procedures are under constant review and therefore times/prices are subject to change; those quoted here must be taken as guidance only. Use TOPIx to obtain the latest repair time.

This program is valid for a limited time only. Warranty claims with a repair date prior to the July 31, 2021, closure date must be submitted or payment within 30 calendar days of completion of the repair.

PROGRAM CODE	OPTION CODE	DESCRIPTION	SRO	TIME (HOURS)	PART NUMBER	QUANTITY
H207	C	VIN F60001-F74390 Hood latch and hood release cable - Renew	76.16.43	0.4	T4K11208	1
					T4K12760	1
H207	D	VIN F60001-F74390 Hood latch and hood release cable - Renew Drive in/drive out	76.16.43 10.10.10	0.4	T4K11208	1
				0.2	T4K12760	1
H207	E	VIN F74391-F79532 Right hood latch - Renew	99.02.19	0.3	T4K11208	1
H207	F	VIN F74391-F79532 Right hood latch - Renew Drive in/drive out	99.02.19 10.10.10	0.3	T4K11208	1
				0.2	-	-

Normal Warranty policies and procedures apply.

WORKSHOP PROCEDURE A - HOOD LATCH AND HOOD RELEASE CABLE - RENEW

VIN F60001-F74390 only

NOTES:

- Some variation in the illustrations may occur, but the essential information is always correct.
- Some components are shown removed for clarity.

1.

NOTE:

Inspect the panel alignment across the entire length and width of the hood.

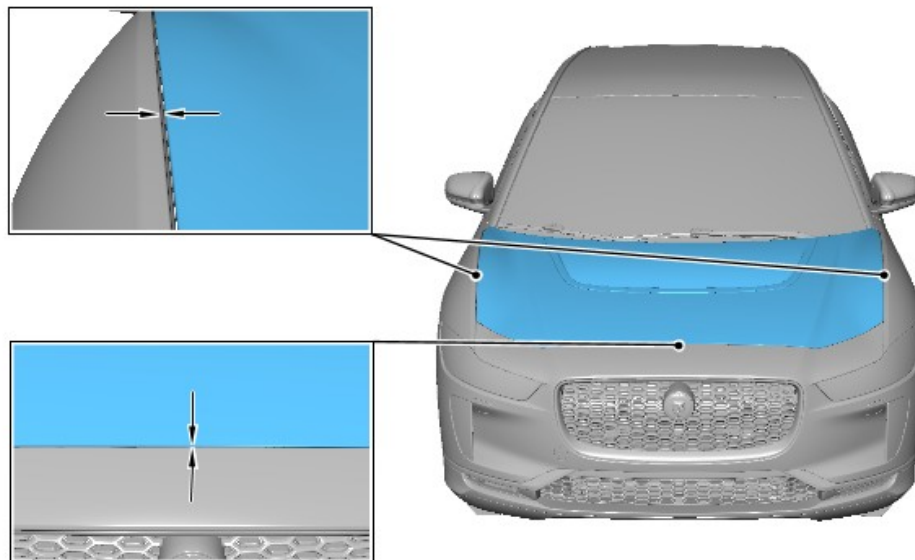

E247677

Measure and record the gap and flush condition from the hood to the front bumper and both front fenders.

2. Open the hood.

3. Remove the front stowage compartment (see TOPIx Workshop Manual section 501-02: Front End Body Panels - Removal and Installation - Front Stowage Compartment).

4.

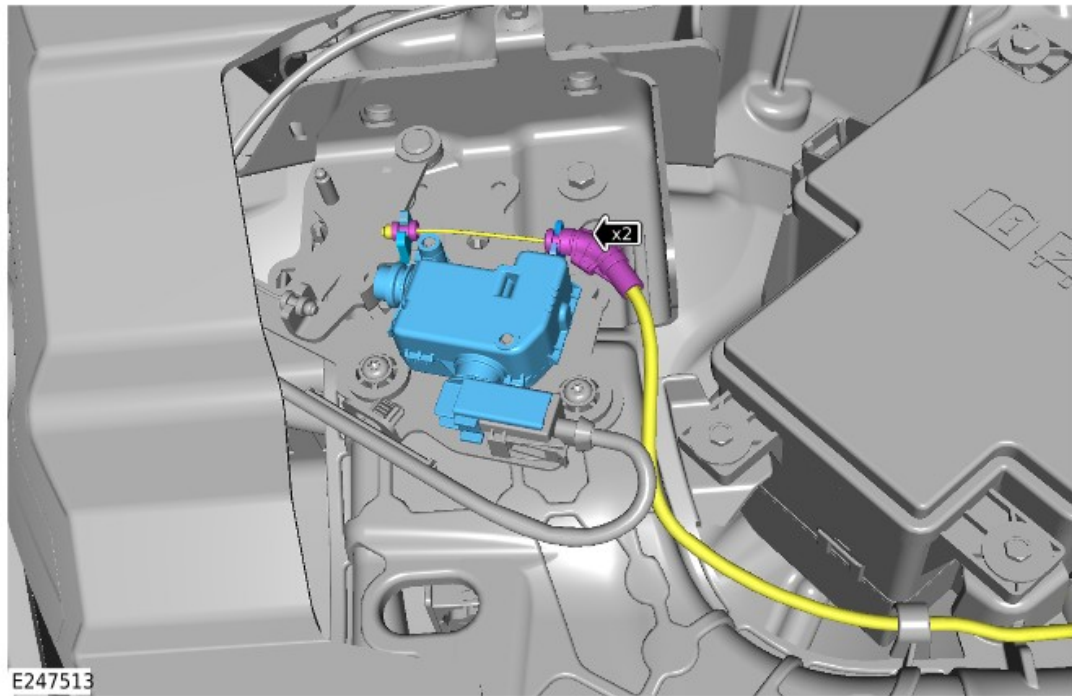

Remove the hood release cable from the hood release actuator.

- **1.** Release the 2 hood release cable clips.

5.

NOTE:

Note the installed position of the right hood latch before removing.

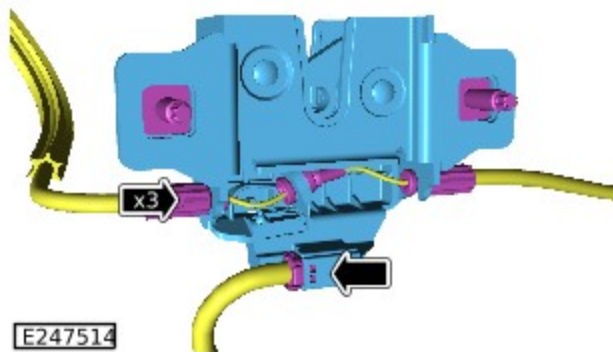
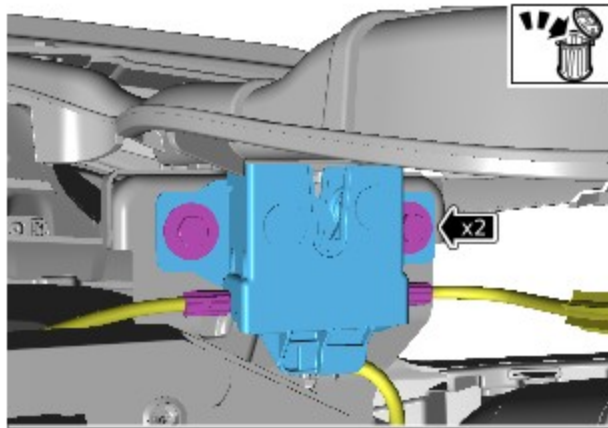

Remove and discard the right hood latch.

- **1.** Remove the 2 bolts.
- **2.** Disconnect the electrical connector.
- **3.** Release the 3 hood release cable clips.

6.

NOTES:

- Note the installed position of the left hood latch before removing.
- Do not discard the left hood latch.

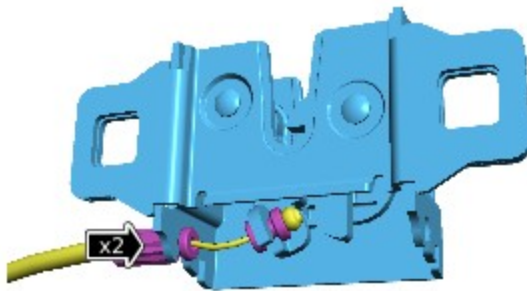
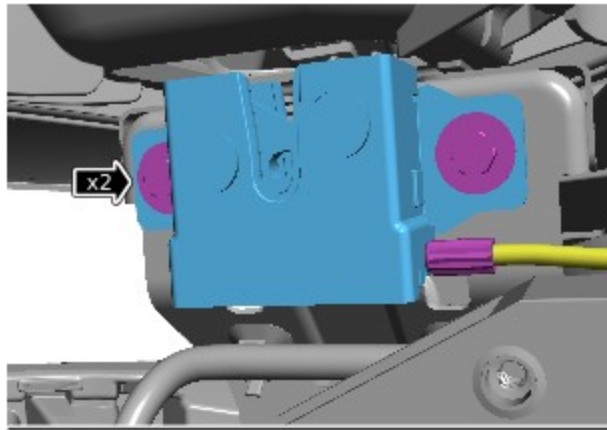
**E247515**

Remove the left hood latch.

- **1.** Remove the 2 bolts.
- **2.** Release the 2 hood release cable clips.

7.

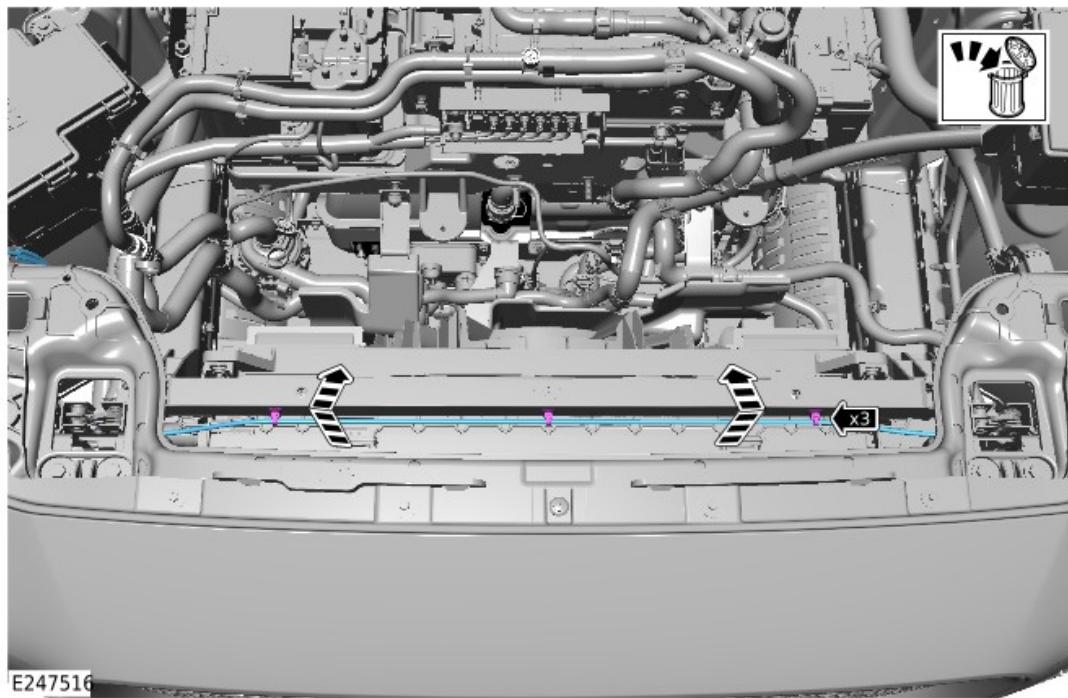

Remove and discard the hood release cable.

- 1. Release the 3 retaining clips

8.

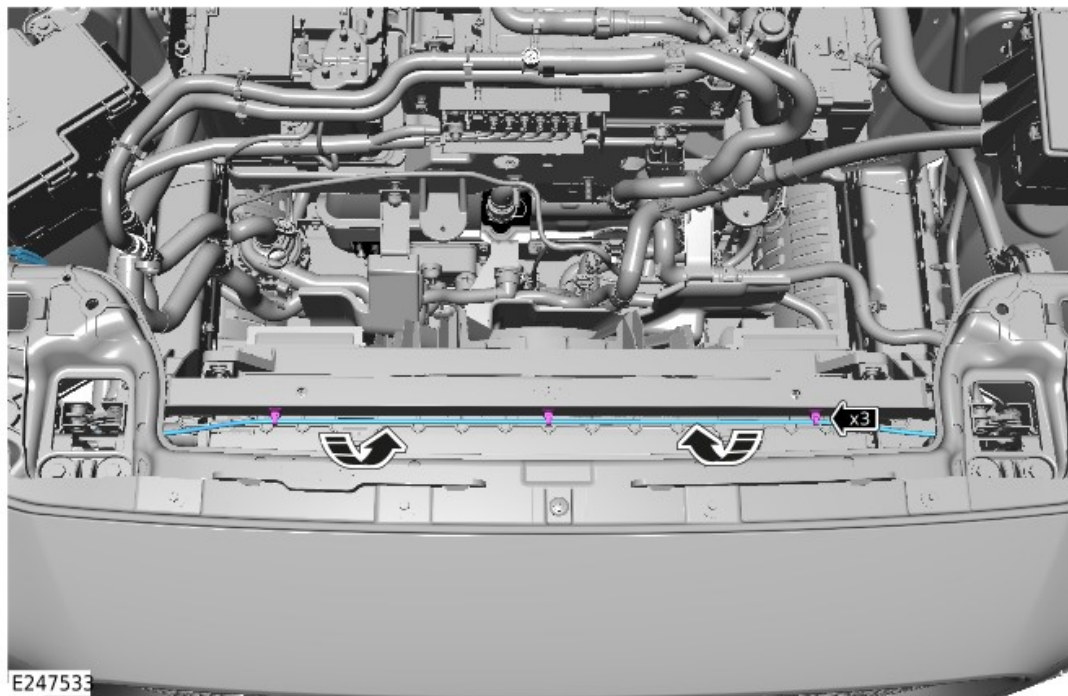

Install the new hood release cable.

- 1. Secure the 3 retaining clips

9.

NOTE:

Install the left hood latch in the position noted during the removal step.

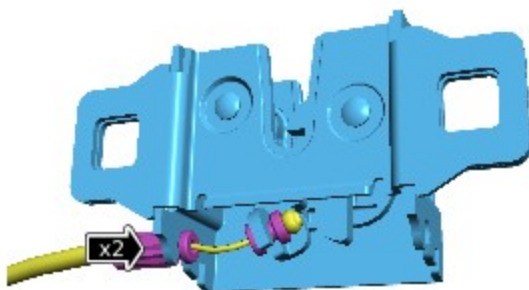
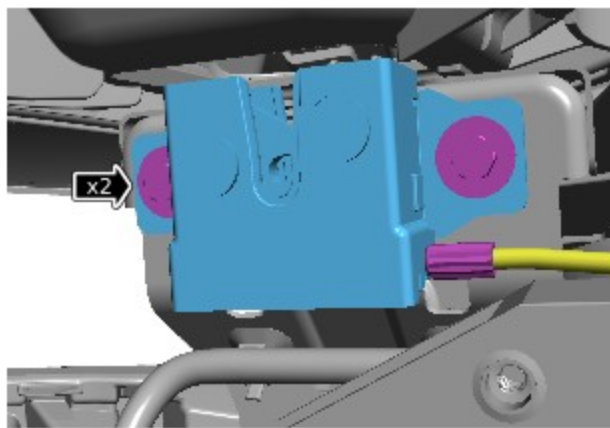
**E247515**

Install the original left hood latch.

- **1.** Secure the 2 hood release cable clips.
- **2.** Install and tighten the 2 bolts.
 - ■ Torque: **10 Nm**

10.

NOTE:

Install the right hood latch in the position noted during the removal step.

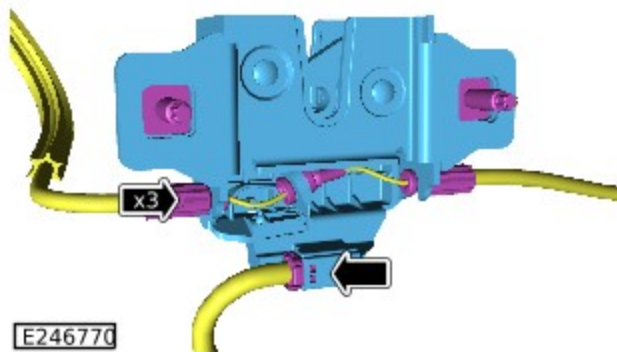
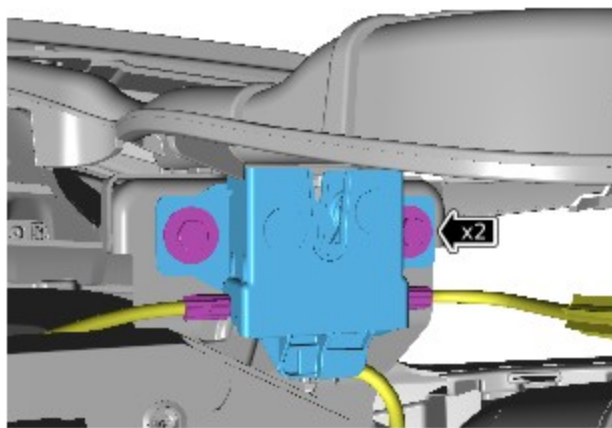

Install the new right hood latch.

- **1.** Secure the 3 hood release cable clips.
- **2.** Connect the electrical connector.
- **3.** Install and tighten the 2 bolts.
 - ■ Torque: **10 Nm**

11.

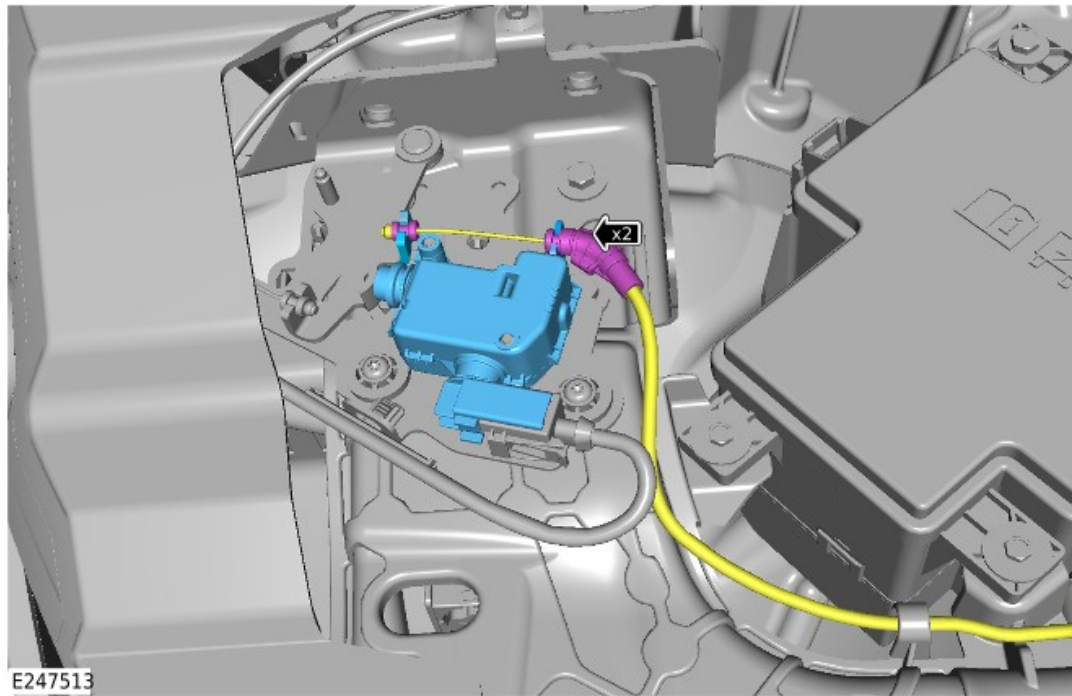

Install hood release cable to the hood release actuator.

- **1.** Secure the 2 hood release cable clips.

12. Close the hood.

13.

NOTE:

Inspect the panel alignment across the entire length and width of the hood.

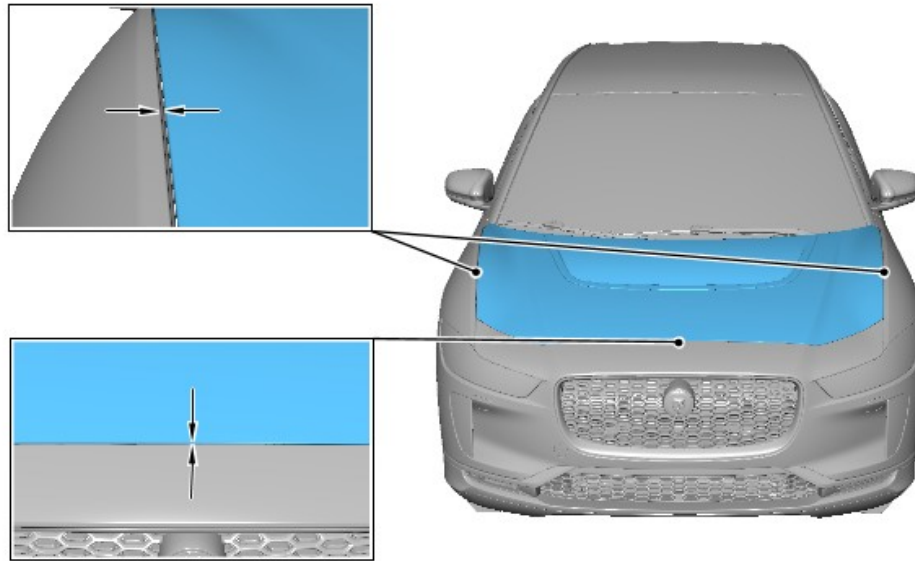

E247677

Measure the gap and flush condition from the hood to the front bumper and both front fenders.

- ■ If the gap and flush condition measurements from the hood to the front bumper and both front fenders **are** the same as noted during step 1, go to step 14.
- ■ If the gap and flush condition measurements from the hood to the front bumper and both front fenders **are not** the same as noted during step 1, adjust the hood latch positions until the correct measurement is achieved and then go to step 14.

14. Open the hood.

15. Install the front stowage compartment (see TOPIx Workshop Manual section 501-02: Front End Body Panels - Removal and Installation - Front Stowage Compartment).

WORKSHOP PROCEDURE B - RIGHT HOOD LATCH - RENEW

VIN F74391-F79532 only

NOTES:

- Some variation in the illustrations may occur, but the essential information is always correct.
- Some components are shown removed for clarity.

1.

NOTE:

Inspect the panel alignment across the entire length and width of the hood.

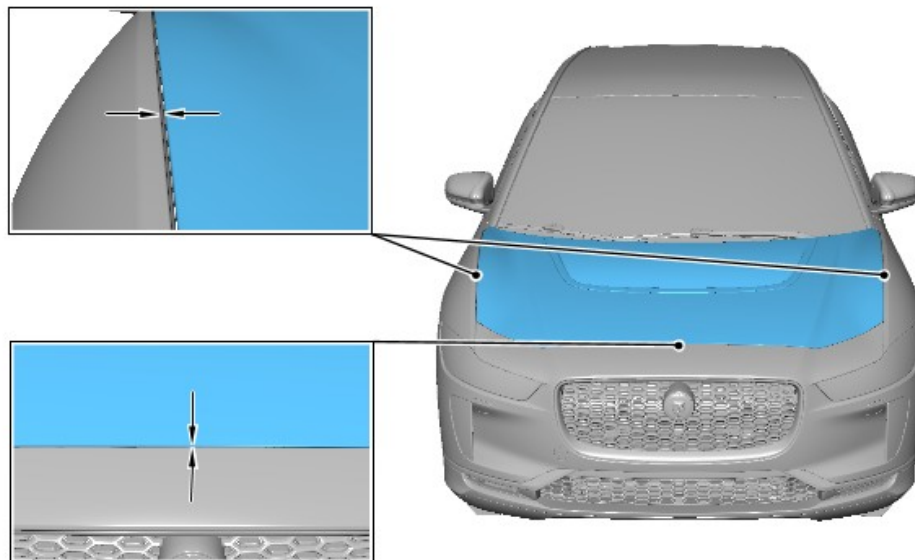

E247677

Measure the gap and flush condition from the hood to the front bumper and both front fenders.

2. Open the hood.

3. Remove the front stowage compartment (see TOPIx Workshop Manual section 501-02: Front End Body Panels - Removal and Installation - Front Stowage Compartment).

4.

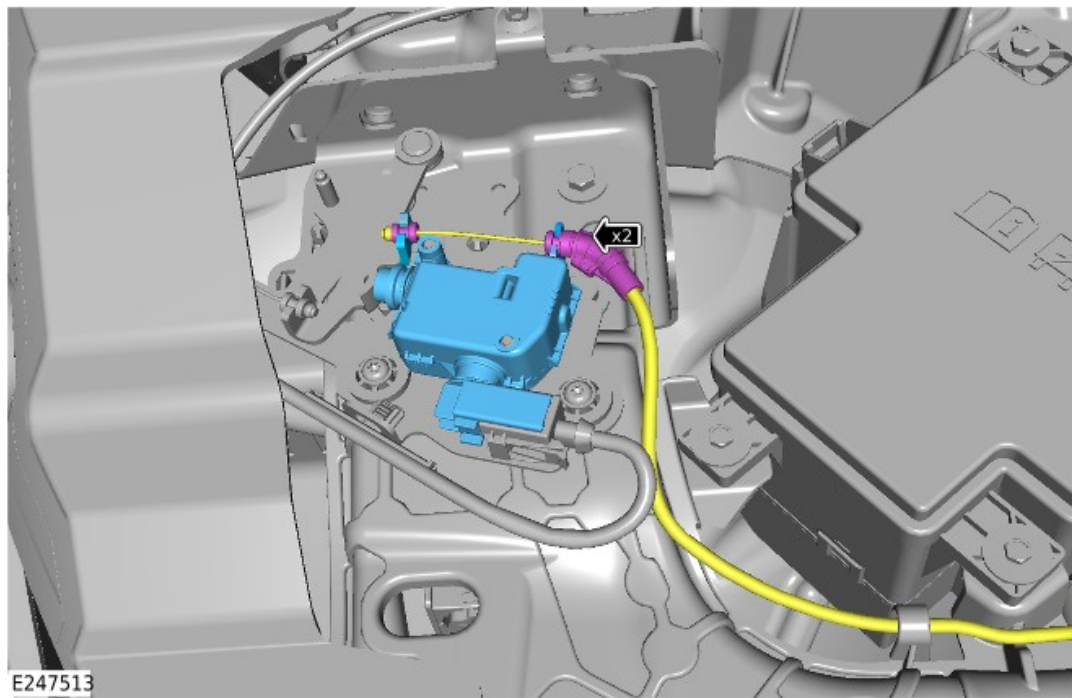

Remove the hood release cable from the hood release actuator.

- **1.** Release the 2 hood release cable clips.

5.

NOTE:

Note the installed position of the right hood latch before removing.

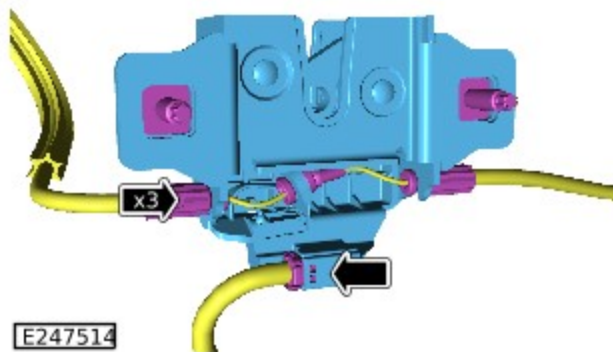
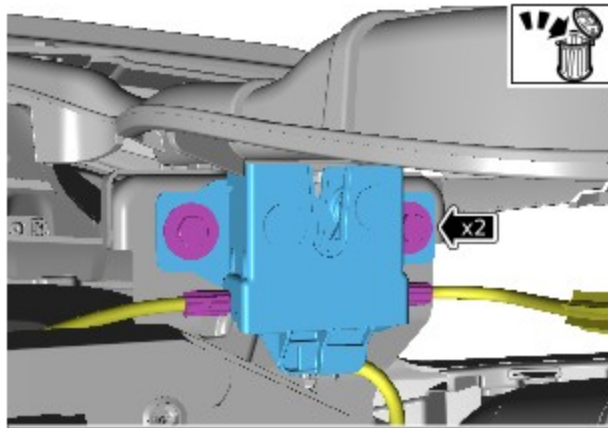

Remove and discard the right hood latch.

- **1.** Remove the 2 bolts.
- **2.** Disconnect the electrical connector.
- **3.** Release the 3 hood release cable clips.

6.

NOTE:

Install the right hood latch in the position noted during the removal step.

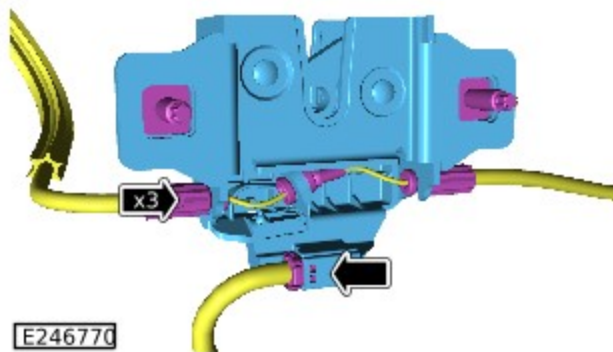
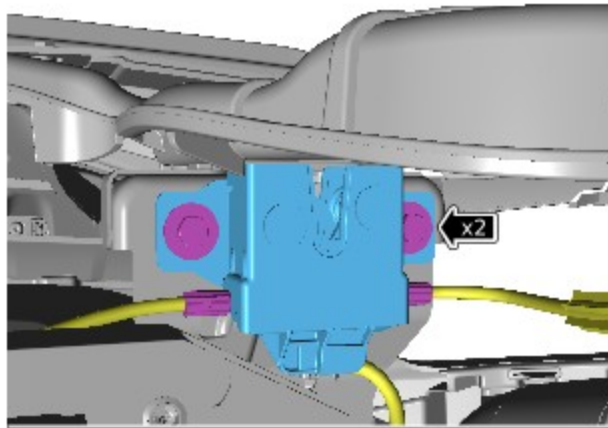

Install the new right hood latch.

- **1.** Secure the 3 hood release cable clips.
- **2.** Connect the electrical connector.
- **3.** Install and tighten the 2 bolts.
 - ■ Torque: **10 Nm**

7.

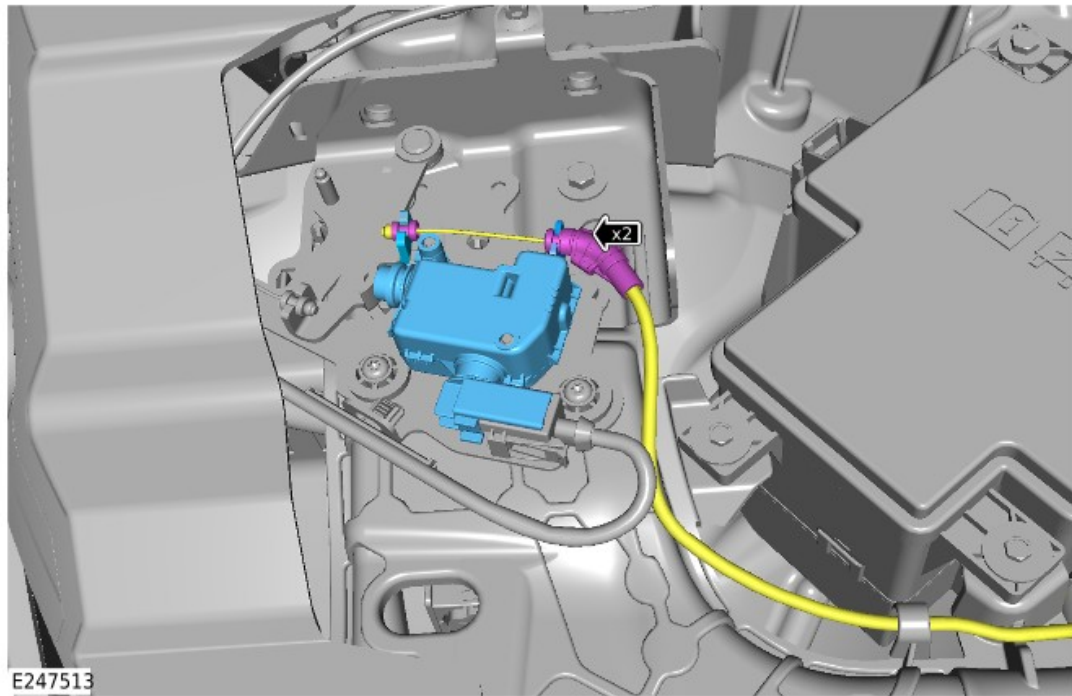

Install hood release cable to the hood release actuator.

- **1.** Secure the 2 hood release cable clips.

8. Close the hood.

9.

NOTE:

Inspect the panel alignment across the entire length and width of the hood.

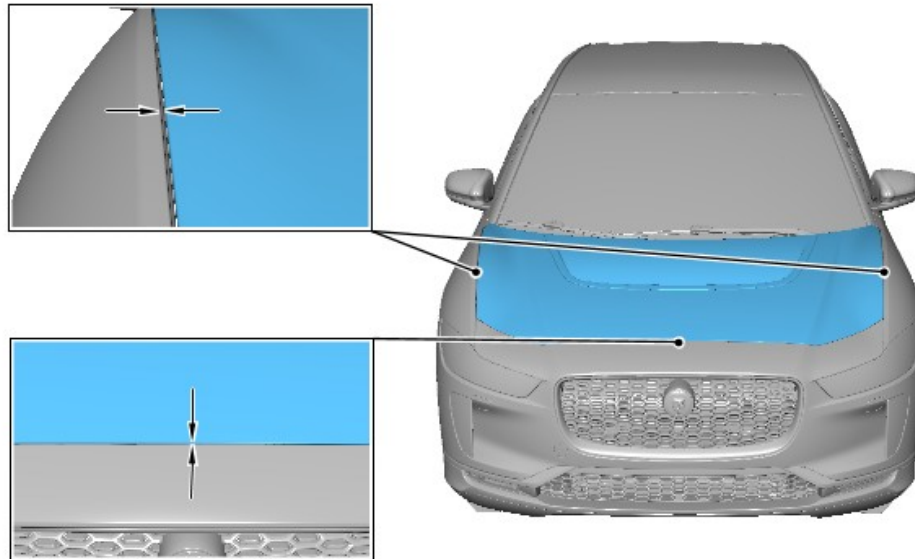

E247677

Measure the gap and flush condition from the hood to the front bumper and both front fenders.

- ■ If the gap and flush condition measurements from the hood to the front bumper and both front fenders **are** the same as noted during step 1, goto step 10.
- ■ If the gap and flush condition measurements from the hood to the front bumper and both front fenders **are not** the same as noted during step 1, adjust the hood latch positions until the correct measurement is achieved and then go to step 10.

10. Open the hood.

11. Install the front stowage compartment (see TOPIx Workshop Manual section 501-02: Front End Body Panels - Removal and Installation - Front Stowage Compartment).