



## Condition

**ATTENTION:**

**THIS IS A TECH TIP, NOT A TECHNICAL BULLETIN.**

**TECH TIPS ARE NOT ASSOCIATED WITH WARRANTY CLAIMING.**

Applicable Vehicles					
Model(s)	Year	Eng. Code	Trans. Code	VIN Range From	VIN Range To
All	2010 -2021	All	All	All	All

Revision Table			
Instance Number	Published Date	Version Number	Reason For Update
2059380/2	4/30/20	97-20-01TT	Update pictures for clarity.
2059380/1	4/24/20	97-20-01TT	Original publication.

## Technical Background

Technical direction for testing voltage drop in a circuit.

## Service

The purpose of voltage in a circuit is to provide the required electrical energy to operate a load. Resistance and voltage drop across a load (such as a light bulb) are required for circuits to work correctly. But, in the wrong place (such as corrosion in a connector) resistance and voltage drop may cause electrical issues, such as dim bulbs, slow motors, heated wires, etc. A load can be defined as anything that causes resistance. This includes the wires and devices like switches, diodes, bulbs, or motors, etc.

Resistance can also be created by partial connectivity caused by loose terminal pins, pitted relay contacts, loose connections, or even corrosion. If a circuit has excessive resistance, it prevents the wire or component from carrying sufficient current under high load conditions. In a normally operating circuit, normal resistance is small enough that it doesn't keep the load from operating properly. When measuring voltage in a circuit, you'll find that it is lower after the load (resistance) than it was before the load. The "voltage drop" or the amount that voltage lowers as it goes through a load is an indication or measure of how much electrical energy was used when it was converted into another form of energy (light, heat, or electromagnetic movement). The reason for using a voltage drop test rather than just an ohm meter to measure resistance, is that sometimes a resistance is not evident (not measureable) unless the circuit is placed under load. To measure voltage drop in a circuit, the circuit must be activated and under load.



97-20-01TT Voltage Drop Testing Procedures

Release date: 4/30/2020

**!** **Note:** Before starting a test always check the wiring diagram. Some vehicle circuits may have a resistor intentionally installed to reduce voltage and current. Examples include the rheostat that dims the instrument panel lights, ballast resistors in some fuel injector circuits, and motor resistors used to limit blower fan and electric fuel pump speeds. Be sure you know your circuit and identify any "intentional" resistance that can give high ohm reading or high voltage drop readings. Also, the wiring diagram often has specifications for electrical testing.

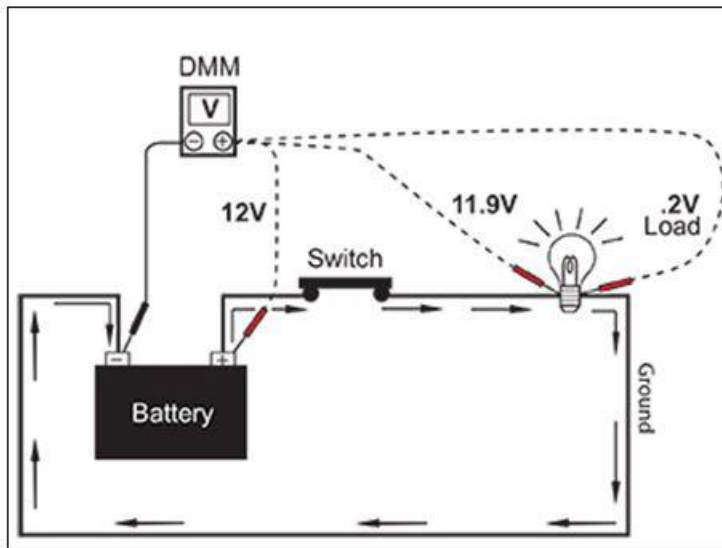

When performing a voltage drop test as shown in this example; the volt meter's positive lead should be connected to the circuit, in the direction of the power source and negative lead toward the ground.

Operate or turn ON the circuit. Voltage will always follow the path of least resistance. So, if there is excessive resistance in the circuit, your meter becomes the path of least resistance for some voltage and will give a voltage reading.

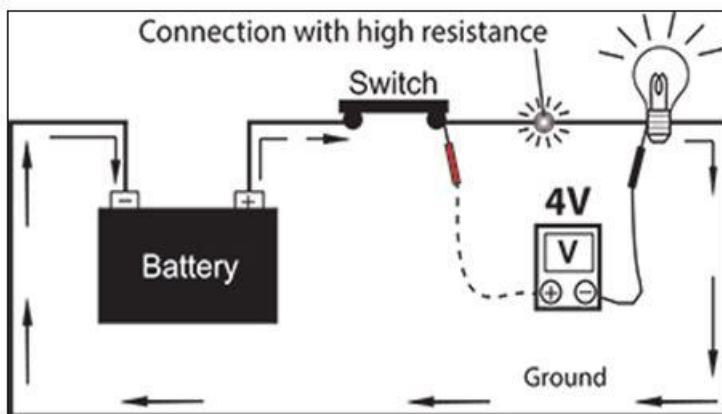

**Meter #1**

12 volts at the battery.



**Meter #2**

0 volt reading between the battery positive post and the switch. The wire has no resistance so all of the voltage goes through the wire and none goes through the meter, giving a 0 volt reading - no voltage drop.

**Meter #3**

0.1 volt drop across the switch. The switch has a small resistance. 11.9 volts goes through the switch and the remaining voltage (0.1 volts) goes through the meter, giving a voltage drop reading of 0.1 volts.

**Meter #4**

4.0 volt drop across the damaged wire. The wire has high resistance at the fault point, allowing only 7.9 volts through the wire. The remaining 4 volts takes the path of least resistance through the meter giving a voltage drop reading of 4 volts. A voltage drop this high will likely cause problems, such as a dim bulb.

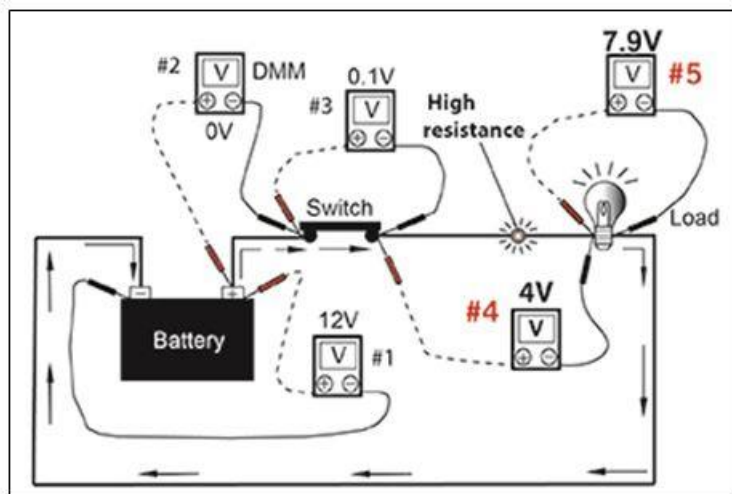

Voltage drop is the amount of voltage lost as it passes through a component or resistance in a circuit. In order to perform a voltage drop test, voltage must be present in a circuit. It's the difference between voltage at the source or battery and the voltage at the component. The meters leads are connected in parallel with the circuit being tested.

To test voltage drop in the starter circuit, the starter must be cranking the engine with the volt meter connected in parallel to the starter cables.

To test the positive starter cable, connect the red lead from the DVOM to the positive battery terminal and connect the black lead to the cable connection on the starter. The voltage drop should not exceed 0.5 volts.

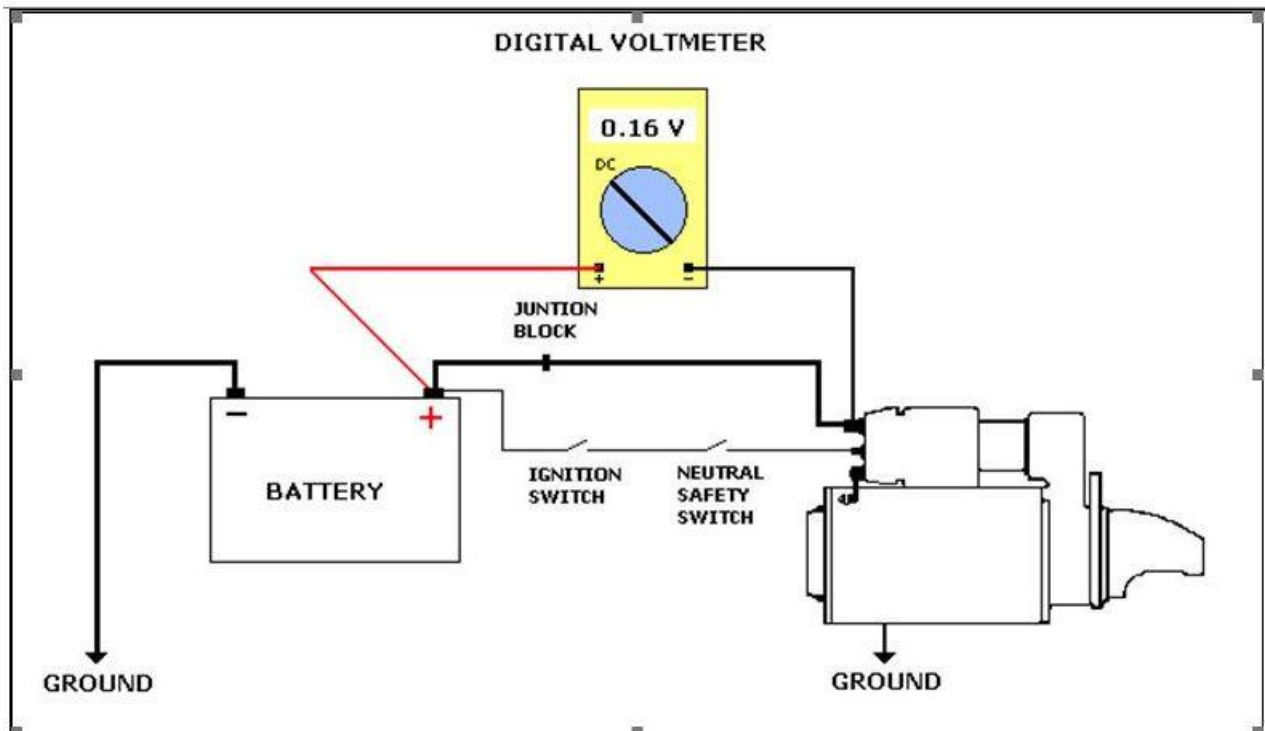

Test voltage drop on the ground side by placing the black lead of the DVOM to the negative battery terminal and place the red lead to the housing of the starter and activate the starter. If the voltage drop exceeds 0.5 volts, move the red lead from the starter housing to the ground cable connection on the engine block or transmission housing. At this point we are testing the voltage drop between the negative battery terminal and the ground cable connection. If the voltage drop exceeds 0.5 volts, replace the ground cable or clean the ground connection.

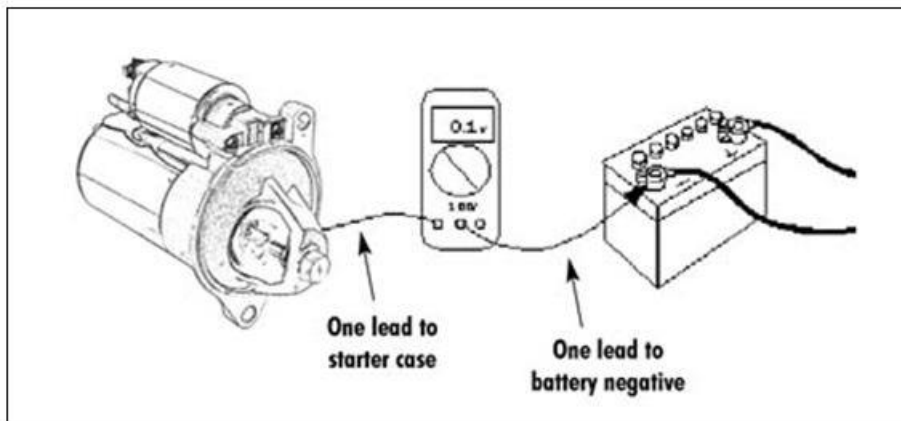

### Additional Information

© 2020 Volkswagen Group of America, Inc. All rights reserved. Information contained in this document is based on the latest information available at the time of printing and is subject to the copyright and other intellectual property rights of Volkswagen Group of America, Inc., its affiliated companies and its licensors. All rights are reserved to make changes at any time without notice. No part of this document may be reproduced, stored in a retrieval system, or transmitted in any form or by any means, electronic, mechanical, photocopying, recording, or otherwise, nor may these materials be modified or reposted to other sites, without the prior expressed written permission of the publisher.