



DTC (Code) P20E8-92 Codigo:	Bulletin: RD18-002 Date Fecha: July 2, 2018
Description:	Reductant Pressure Too Low - Performance or incorrect operation
Application:	US13 – US20 Emissions

General Information

These repair instructions are intended to address the following fault(s):

DTC	Description	Possible Cause	Possible (Observable) Symptoms
P20E8-92	Reductant Pressure Too Low - Performance or incorrect operation	<ul style="list-style-type: none"> • Empty tank • Frozen aftertreatment diesel exhaust fluid (DEF) • DEF Supply from Aftertreatment DEF Tank disconnected • Aftertreatment DEF Line(s) Leakage • Aftertreatment DEF dosing valve Leakage • Aftertreatment Diesel Exhaust Fluid (DEF) Pump Leakage • Damaged sending unit inside the aftertreatment DEF tank • Damaged or clogged filter • Aftertreatment DEF Dosing Pressure Sensor, Incorrect value • Blocked DEF tank ventilation hose • Air in the system • Crystallization inside the DEF pump • Low level in Placeholder 	<ul style="list-style-type: none"> • No aftertreatment diesel exhaust fluid (DEF) dosage • Engine de-rated

Required Parts

Part Number	Description	Quantity
21576178	Diesel Exhaust Fluid (DEF) Pump Unit	1

Repair Instructions

Aftertreatment Diesel Exhaust Fluid (DEF) Pump Unit, Replacement

DTC (Code) P20E8-92
Codigo:

Bulletin: RD18-002
Date Fecha: July 2, 2018

Before replacing the DEF Pump Unit please check for damaged return hoses and connectors.

- Disconnect and clean the aftertreatment DEF lines between the DEF tank and the DEF pump using water and compressed air. If the line is broken then it will have to be replaced.



Removal

1. Apply parking brake and place shift lever in neutral.
2. Open rear engine service doors.
3. Remove all cables from ground (negative) battery terminals to prevent personal injury from electrical shock and prevent damage to electrical components.
4. Open right rear engine service door.
5. Connect the coolant extractor to the drain fitting at the bottom of the radiator and drain the coolant. Note: An alternate method is to connect the coolant drain hose to the drain fitting and drain the coolant into a suitable container. Special tools: 85112740, 9996049
6. Place a suitable container under the DEF tank to catch fluid that may drain from the pump. Note: Use protective equipment and an approved suitable container. Dispose of DEF according to local regulations.
7. Mark the DEF lines before removal. Remove the DEF inlet, backflow and outlet lines from the pump. Place protective caps on the DEF lines. *Note: For information on the handling of DEF, refer to "General Safety Practices", Group 20. Note: If inlet and backflow lines are switched, the system will not start.*

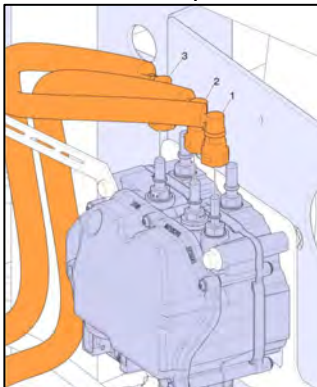

1. DEF Outlet Line
2. DEF Backflow Line
3. DEF Inlet Line

DTC (Code) P20E8-92
Codigo:

Bulletin: RD18-002
Date Fecha: July 2, 2018

8. Remove the inlet and outlet coolant lines from the pump. Place protective caps on the coolant lines.

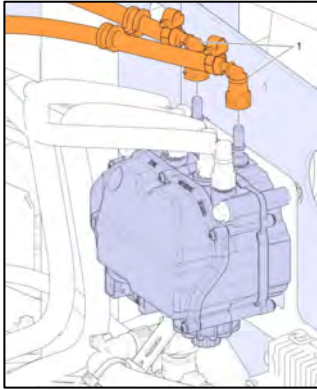

1. Coolant Lines

9. Remove cable tie and disconnect the wiring harness connector from the DEF pump. Cover the wiring harness connector with a plastic bag to protect from possible damage from DEF.

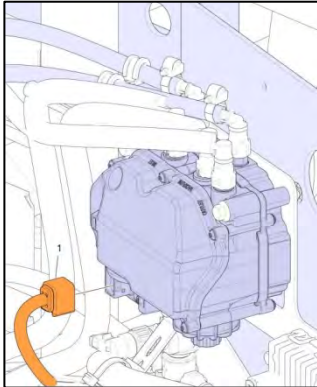

10. Remove the fasteners, brackets and DEF pump from the mounting bracket.

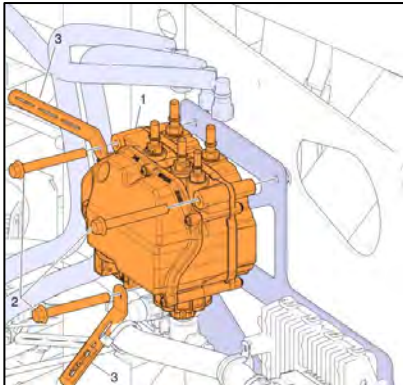

1. DEF Pump
2. Fasteners
3. Brackets



DTC (Code) P20E8-92
Codigo:

Bulletin: RD18-002
Date Fecha: July 2, 2018

Installation

1. Position the DEF pump onto the mounting bracket and install brackets and fasteners. Tighten the fasteners to specification, refer to Function Group 20, Specifications.
2. Remove plastic bag from the wiring harness connector. Attach the wiring harness connector to the DEF pump and secure the harness using a cable tie.
3. Install the inlet and outlet coolant lines onto the DEF pump.
4. Install DEF inlet, backflow and outlet lines onto the pump. Note: If inlet and backflow lines are switched, the system will not start.
5. Fill the cooling system with the recommended coolant using the coolant extractor. Ensure the coolant system is full. Special tools: 85112740
6. Install all previously removed cables to the ground (negative) battery terminals.
7. Connect Tech Tool to the vehicle. Use Guided Diagnostics to read and clear any diagnostic trouble codes (DTCs). Check for proper operation and for leaks.
8. Close right rear engine service door.
9. Close rear engine service doors.

Additional Resources

These repairs are the most likely fix for the identified fault, if this does not fix the issue, Tech Tool will need to be used for more detailed diagnostics. If filing a warranty claim, please include the ASIST case number.

Labor Code	
2589-03-02-36	1.2
Causal Part	21576178