

WLC8 - Replacing Tank Leakage Diagnosis Module (Workshop Campaign)

Model line: **911 Carrera (991)**

Model Year: **As of 2012 up to 2016**

Equipment: Tank leakage diagnosis (I-no. **664**)

Subject: **Tank leakage diagnosis module**

Information: **Under certain regional environmental conditions, e.g. dust and humidity, there is a possibility that particles of dirt can get into the tank leakage diagnosis module.**

This can cause over-sensitive tank leakage diagnosis and the Check Engine light may be activated.

Remedial Action: Replace tank leakage diagnosis module and air filter for carbon canister.

Affected Vehicles: Only the vehicles assigned to the campaign (see also PCSS Vehicle Information). This campaign affects 26,217 vehicles in North America.

Parts required

Parts Info:	Part No.	Designation	Qty.
	00004321110	⇒ Pressure switch for tank leakage diagnosis module	1 ea.
	00004321007	⇒ Filter	1 ea.

Required tools

- Tools:
- Torque screwdriver, 1.5 – 3 Nm (1 – 2 ftlb.), e.g. **Torque screwdriver, 1.5-3 Nm (1-2 ftlb.), VAS 6494**
 - Torque wrench, 6 – 50 Nm (4.5 – 37 ftlb.), e.g. **Torque wrench, 6-50 Nm (4.5-37 ftlb.), VAG 1331A**

Replacing tank leakage diagnostic module

Work Procedure: 1 Removing carbon canister

- 1.1 Move cover in luggage compartment to service position ⇒ *Workshop Manual '852219 Removing and installing cover'.*

- 1.2 Loosen battery retaining bracket and push the battery with connected lines to the right. For instructions, see ⇒ *Workshop Manual '270619 Removing and installing battery'*.
 - 1.3 Open housing cover for pre-filter and remove the pre-filter ⇒ *Workshop Manual '850819 Removing and installing air intake pre-filter'*.
 - 1.4 Remove carbon canister with tank leakage diagnosis module ⇒ *Workshop Manual '202519 Removing and installing carbon canister'*.
- 2 Remove tank leakage diagnosis module from the carbon canister.

- 2.1 Loosen and unscrew fastening screws ⇒ *Loosening tank leakage diagnosis module -2-* for the tank leakage diagnosis module ⇒ *Loosening tank leakage diagnosis module -1-*.

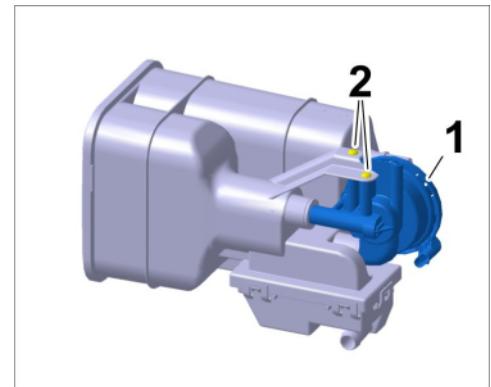

Loosening tank leakage diagnosis module

- 2.2 Carefully pull tank leakage diagnosis module ⇒ *Removing tank leakage diagnosis module -1-* out of the connection on the carbon canister ⇒ *Removing tank leakage diagnosis module -2-* (⇒ *Removing tank leakage diagnosis module -arrow-*) and remove it.

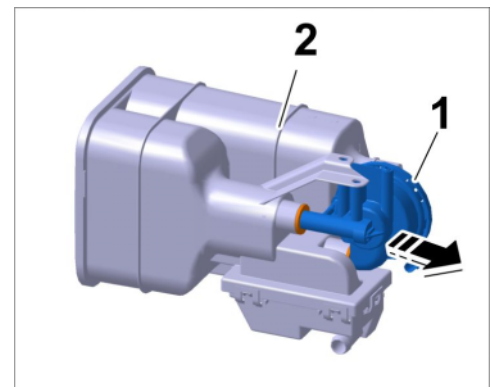

Removing tank leakage diagnosis module

3 **Install new** tank leakage diagnosis module



Information

The following installation sequence must always be observed in order to prevent leaks that can cause fuel or fuel vapors to leak out.

No lubricant (grease, etc.) must be used on the sealing grommet in order to fit the tank leakage diagnosis module on the carbon canister.

3.1 Check the position of the sealing sleeves
 ⇒ *Installing tank leakage diagnosis module -3-*. If necessary, pull the sealing sleeves off the tank leakage diagnosis module you have just removed without using tools and press them into the carbon canister ⇒ *Installing tank leakage diagnosis module -2-*.

3.2 Carefully push connecting pipes for the tank leakage diagnosis module ⇒ *Installing tank leakage diagnosis module -1-* through the sealing sleeves ⇒ *Installing tank leakage diagnosis module -3-* as far as they will go into the connection on the carbon canister ⇒ *Installing tank leakage diagnosis module -2-* (⇒ *Installing tank leakage diagnosis module -arrow-*).

3.3 Screw in and tighten fastening screws ⇒ *Securing tank leakage diagnosis module -2-* for the tank leakage diagnosis module ⇒ *Securing tank leakage diagnosis module -1-*.
Tightening torque 1.5 Nm (1 ftlb.)
 +/-0.3 Nm (+/-0.2 ftlb.)

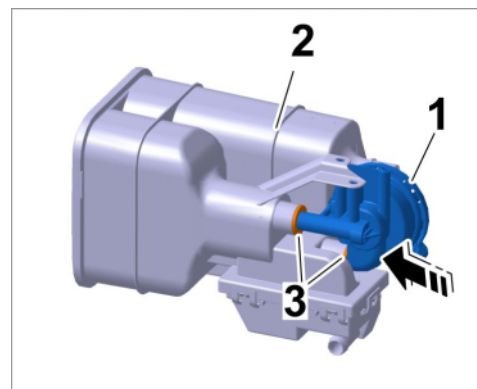

Installing tank leakage diagnosis module

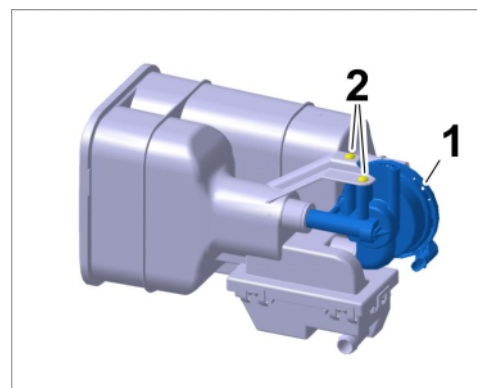

Securing tank leakage diagnosis module

- 4 Replace air filter on the carbon canister
 - 4.1 Unclip cover ⇒ *Replacing air filter -1-* all around the carbon canister ⇒ *Replacing air filter -2-* and remove it.
 - 4.2 Remove air cleaner ⇒ *Replacing air filter -3-* and replace it with a **new** air cleaner.
 - 4.3 Position cover ⇒ *Replacing air filter -1-* on the carbon canister ⇒ *Replacing air filter -2-* and press it in until all locking lugs engage securely.
- 5 Installing carbon canister
 - 5.1 Install carbon canister with tank leakage diagnosis module ⇒ *Workshop Manual '202519 Removing and installing carbon canister'*.
 - 5.2 Install pre-filter ⇒ *Workshop Manual '850819 Removing and installing air intake pre-filter'*.
 - 5.3 Secure the battery ⇒ *Workshop Manual '270619 Removing and installing battery'*.
 - 5.4 Install cover in luggage compartment ⇒ *Workshop Manual '852219 Removing and installing cover'*.
- 6 Enter the campaign in the Warranty and Maintenance booklet.

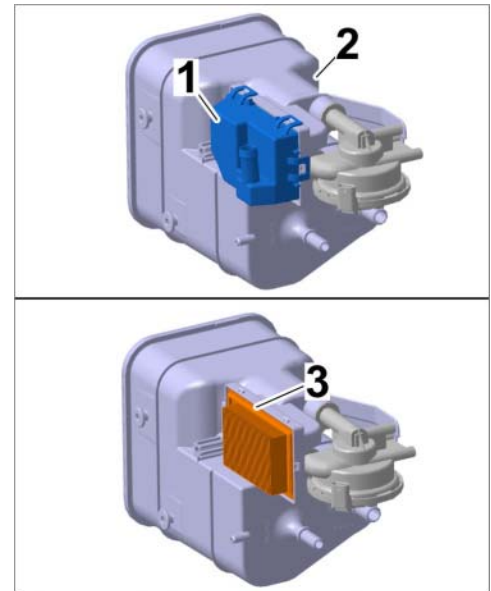

Replacing air filter

Warranty processing

Scope 1:

Working time:		
Replacing tank leakage diagnosis module		Labor time: 42 TU
Includes:	Removing and installing cover in luggage compartment Loosening and securing battery Removing and installing pre-filter Removing and installing carbon canister with tank leakage diagnosis unit	
Parts required:		
00004321110	Pressure switch for tank leakage diagnosis module	1 ea.
00004321007	Filter	1 ea.
⇒ Damage Code WLC8 066 000 2		

Important Notice: Technical Bulletins issued by Porsche Cars North America, Inc. are intended only for use by professional automotive technicians who have attended Porsche service training courses. They are written to inform those technicians of conditions that may occur on some Porsche vehicles, or to provide information that could assist in the proper servicing of a vehicle. Porsche special tools may be necessary in order to perform certain operations identified in these bulletins. Use of tools and procedures other than those Porsche recommends in these bulletins may be detrimental to the safe operation of your vehicle, and may endanger the people working on it. Properly trained Porsche technicians have the equipment, tools, safety instructions, and know-how to do the job properly and safely. Part numbers listed in these bulletins are for reference only. The work procedures updated electronically in the Porsche PIWIS diagnostic and testing device take precedence and, in the event of a discrepancy, the work procedures in the PIWIS Tester are the ones that must be followed.

© 2020 Porsche Cars North America, Inc.