

TECHNICAL INSTRUCTIONS

FOR

SPECIAL SERVICE CAMPAIGN 20TC01

AIR INJECTION PUMPS AND AIR SWITCHING VALVES

CERTAIN 2012 TACOMA

The repair quality of covered vehicles is extremely important to Toyota. All dealership technicians performing this recall are required to successfully complete the most current version of the E-Learning course “Safety Recall and Service Campaign Essentials”. To ensure that all vehicles have the repair performed correctly; technicians performing this recall repair are required to currently hold at least one of the following certification levels:

- Certified (any specialty)
- Expert (any specialty)
- Master
- Master Diagnostic Technician

It is the dealership’s responsibility to select technicians with the above certification level or greater to perform this recall repair. Carefully review your resources, the technician skill level, and ability before assigning technicians to this repair. It is important to consider technician days off and vacation schedules to ensure there are properly trained technicians available to perform this repair at all times.

I. OPERATION FLOW CHART

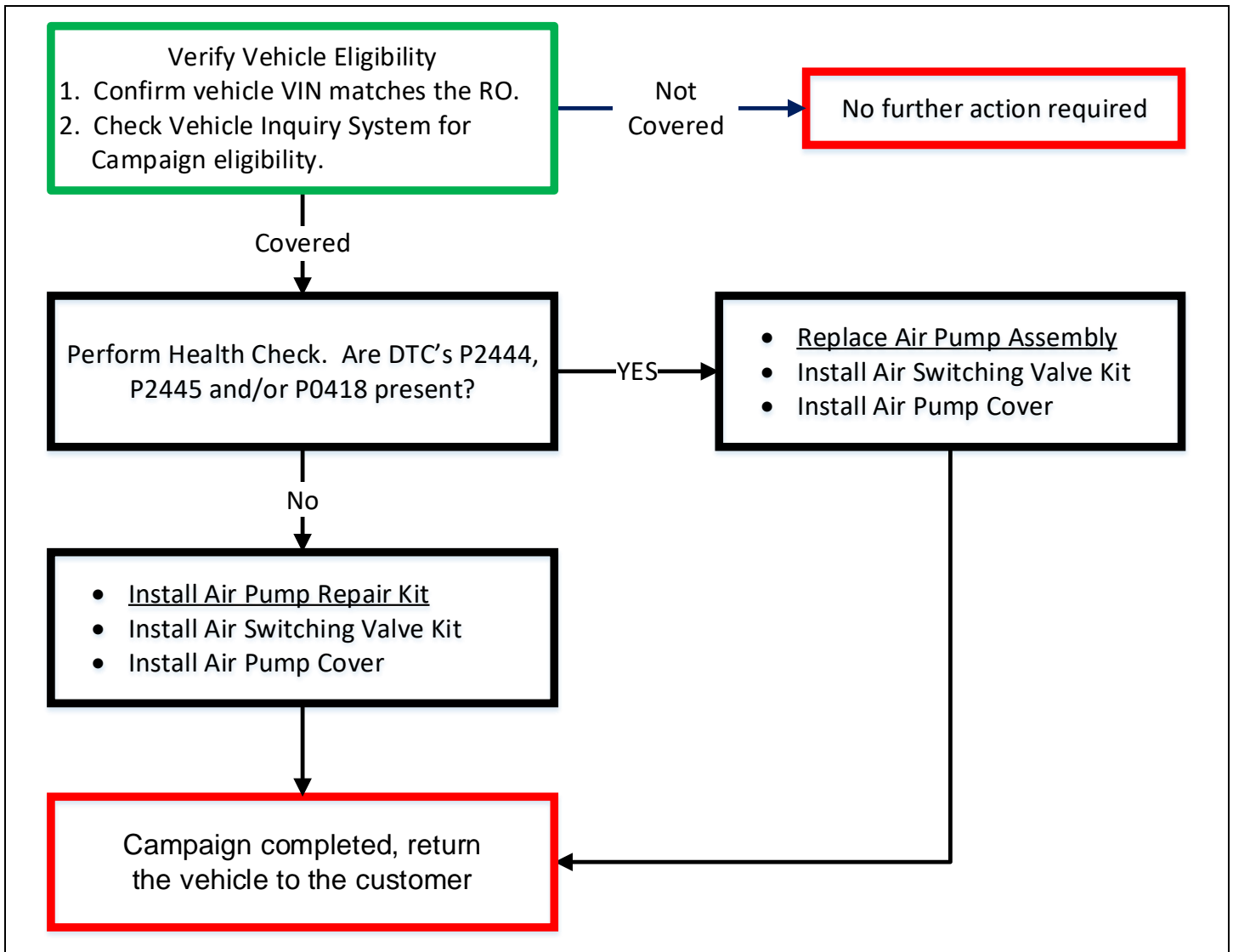

II. IDENTIFICATION OF AFFECTED VEHICLES

1. CHECK VEHICLE FOR CAMPAIGN ELIGIBILITY

- Compare the vehicles VIN to the VIN listed on the Repair Order to ensure they match.
- Check the TIS Vehicle Inquiry System to confirm the VIN is involved in this Campaign, and that it has not already been completed.

Note: TMNA warranty will not reimburse dealers for repairs completed on vehicles that are not affected or were previously completed, even by another dealer.

III. PREPARATION

A. PARTS

Parts for vehicles with None of the applicable DTC's:

Part Number	Part Description	Quantity
04008-34131	Air Switching Valve Kit*	1
04008-3520C	Air Pump Repair Kit**	1
17613-0P010	Cover, Air Pump	1

*The Air Switching Valve Kit includes the following parts:

Part Number	Part Description	Quantity
25710-31022	Valve Assembly, Air Switching	1
17377-31010	Gasket, Air Tube ,No.2	2
17376-50010	Gasket, Air Tube (not used in repair)	2

*The Air Pump Repair Kit includes the following parts:

Part Number	Part Description	Quantity
90166-A0010	Screw, Hexalobular Tapping	1
17617-0C010	Filter, Air Pump	1
17602-0C010	Cover Sub-Assembly, Air Pump Filter (w/ Air Pump Inlet)	1

Parts for vehicles with DTC's P2444, P2445 and/or P0418:

Part Number	Part Description	Quantity
04008-34131	Air Switching Valve Kit*	1
17610-0W020	Assembly, Air Pump	1
17613-0P010	Cover, Air Pump	1

*The Air Switching Valve Kit includes the following parts:

Part Number	Part Description	Quantity
25710-31022	Valve Assembly, Air Switching	1
17377-31010	Gasket, Air Tube ,No.2	2
17376-50010	Gasket, Air Tube (not used in repair)	2

B. TOOLS & EQUIPMENT

- Techstream 2.0 / TIS Techstream /Techstream Lite
- Torque Wrench
- Torx Socket E8
- Standard Hand Tools
- Torx Socket T25

IV. BACKGROUND

There is a possibility that moisture in the air may cause a filter in the vehicle emissions system to degrade. This degradation could cause damage to other parts of the vehicle emission system and illuminate the check engine light (Malfunction Indicator Light).

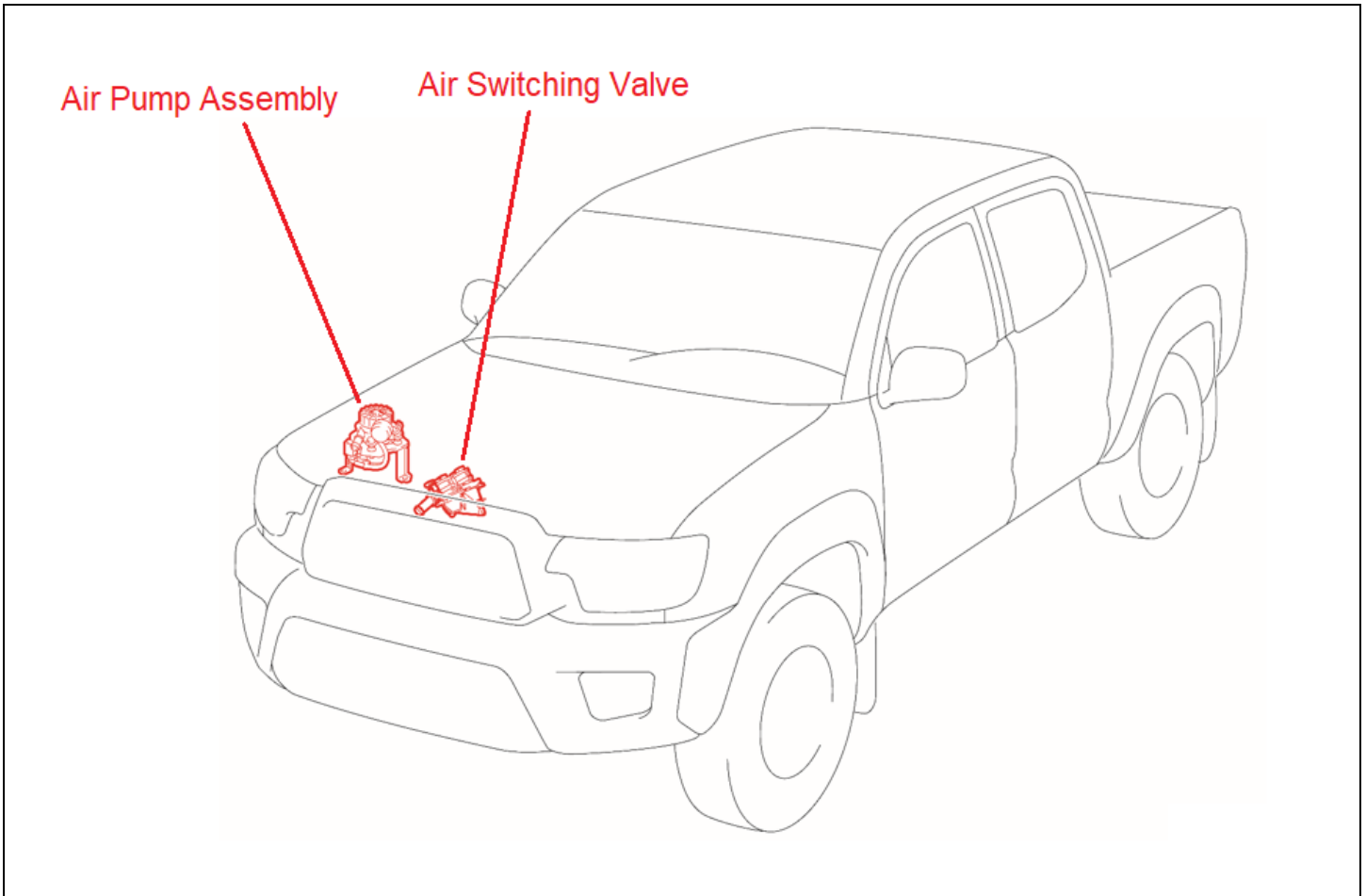

V. COMPONENTS

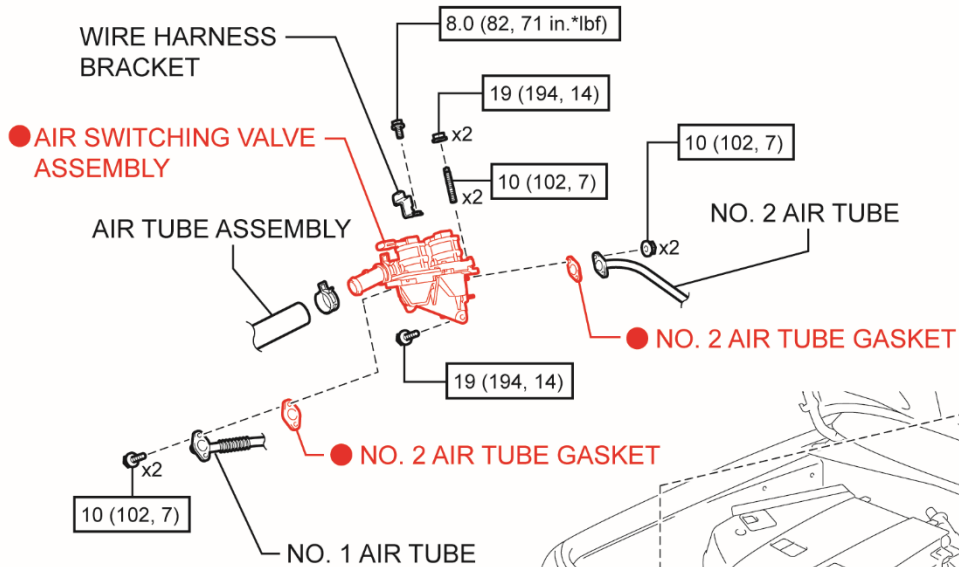
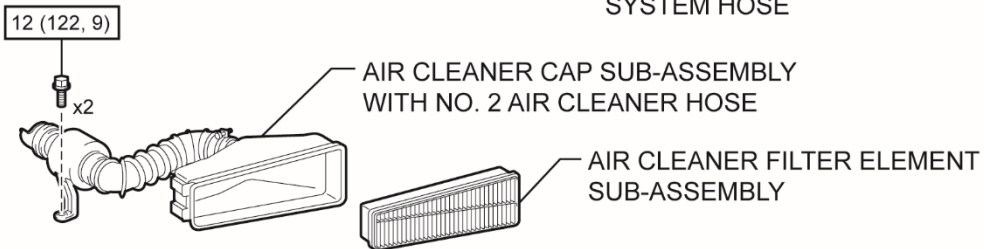
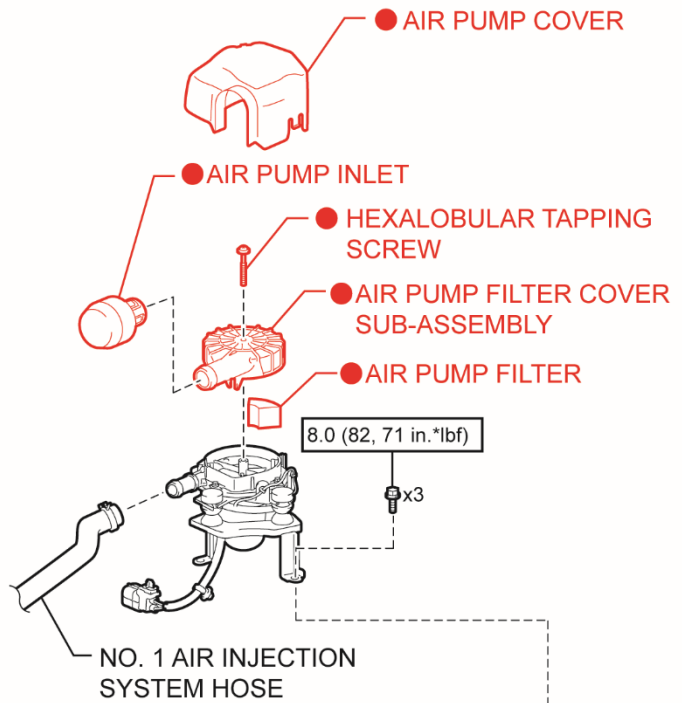
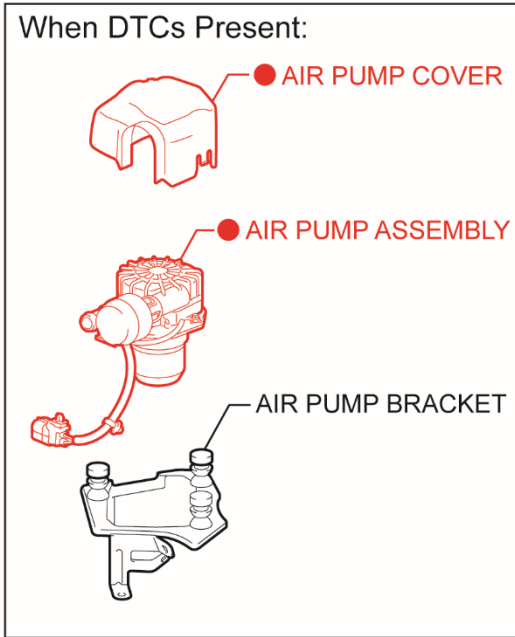

● : Replacement part

N*m (kgf*cm, ft.*lbf) : Specified torque

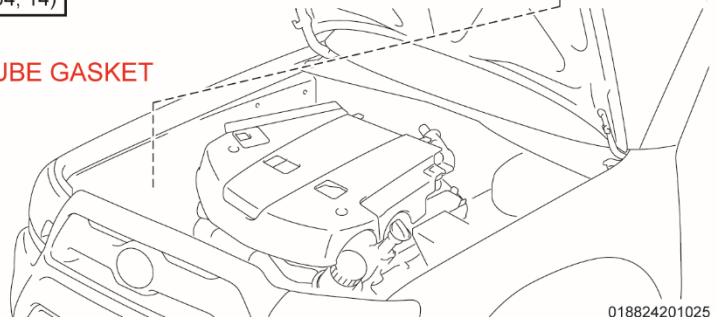

018824201025

VI. INSPECTION



1. CHECK FOR DTC'S

- a. Using a Techstream, check for Diagnostic Trouble Codes.

Note: *This Service Campaign covers only the Air Pump and Air Switching Valves, as detailed in these instructions. It does not cover the diagnosis or replacement of any other parts on the vehicle.*

Is DTC **P2444**, **P2445** and/or **P0418** present?

YES

No

Air Pump Assembly will require replacement. Proceed to Section VIII **REPLACE AIR PUMP ASSEMBLY** on p. 8

Replacement of the Air Pump Assembly will NOT be necessary. Proceed to Section VII **INSTALL AIR PUMP REPAIR KIT** on p. 7

VII. INSTALL AIR PUMP REPAIR KIT

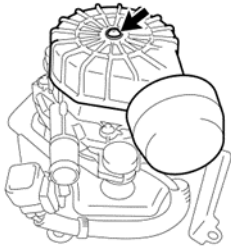

1. REPLACE AIR PUMP FILTER

a. Using a T25 Torx socket, remove the hexalobular tapping screw and air pump filter cover sub-assembly.

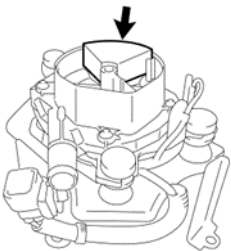

b. Remove the air pump filter.

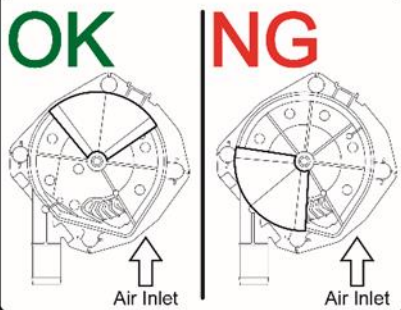

c. Install the **NEW** air pump filter.



Be sure install the air pump filter in the correct position.

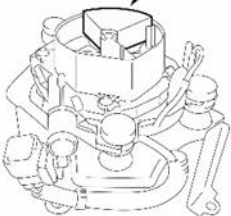

d. Install the **NEW** air pump inlet to the **NEW** air pump filter cover sub-assembly.

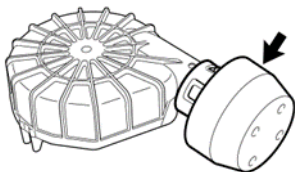

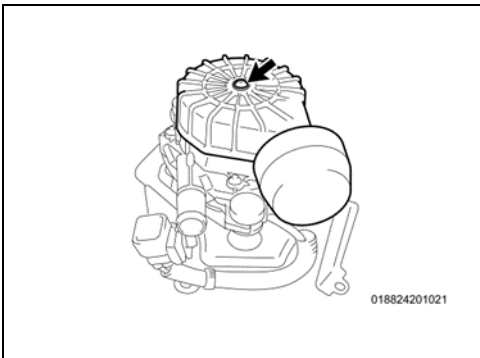

- e. Using a T25 Torx socket, install the **NEW** air pump filter cover sub-assembly with the **NEW** hexalobular tapping screw.

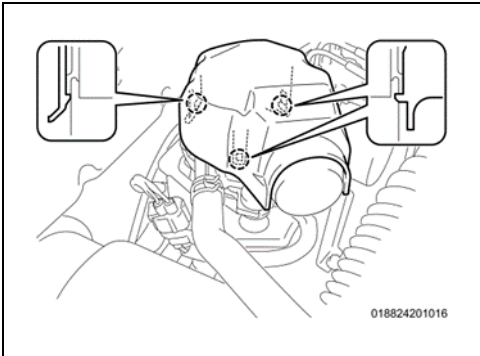

2. **INSTALL THE **NEW** AIR PUMP COVER**
 - a. Install the **NEW** air pump cover with 3 claws.

**Skip to Section IX Air Switching
Valve Replacement on p. 11**

VIII. REPLACE AIR PUMP ASSEMBLY



Air Pump Assembly replacement is only necessary if DTC's P2444, P2445 and/or P0418 are present. **DO NOT** replace the air pump unless these DTC's are present. Install the Air Pump Repair Kit if these DTC's are not present.

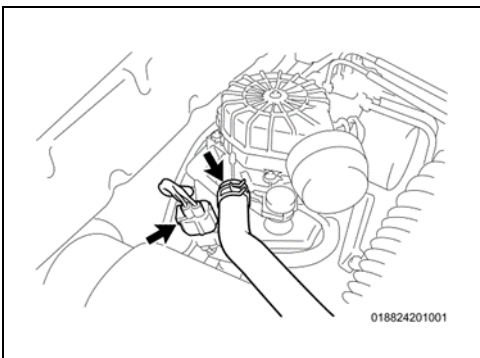

1. **REMOVE ORIGINAL AIR PUMP ASSEMBLY**
 - a. Disconnect the No. 1 air injection system hose.
 - b. Disconnect the air pump connector.

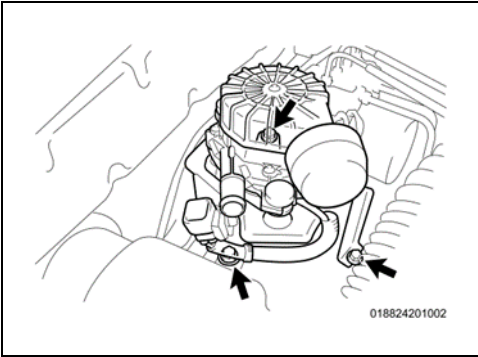

- c. Remove the 3 bolts.
- d. Remove the air pump with bracket.

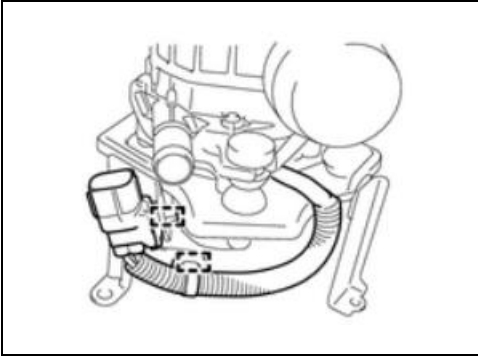

- e. Disconnect the 2 wire harness clamps.

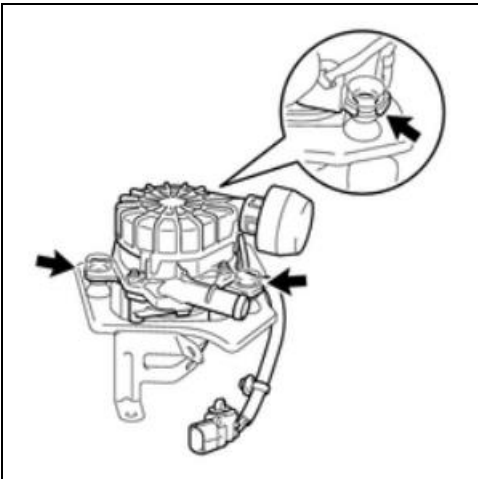

- f. Disengage the 3 fittings of the air pump insulator, and remove the air pump from the bracket.

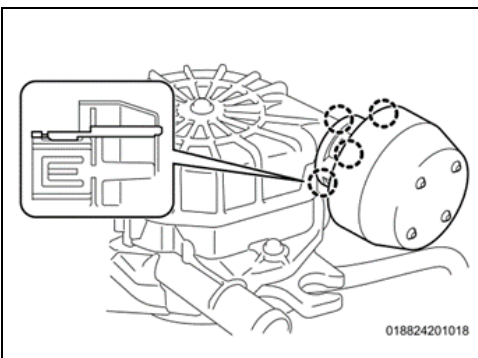

- g. Disengage the 4 claws and remove the air pump inlet from the original air pump assembly.
- h. Install the air pump inlet to the **NEW** air pump assembly.

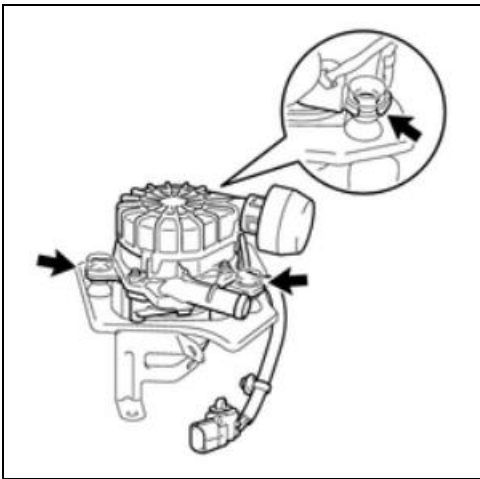

2. INSTALL *NEW* AIR PUMP ASSEMBLY

- a. Install the *NEW* Air Pump Assembly onto the original bracket.
- b. Engage the 3 fittings.
- c. Connect the 2 wire harness clamps.

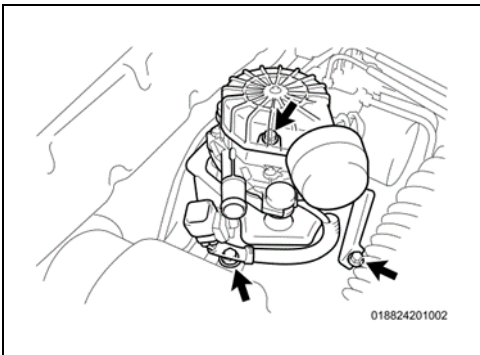

- d. Install the *NEW* air pump with bracket with 3 bolts into the vehicle.

Torque: 8.0 N·m {82 kgf·cm, 71 in·lbs}

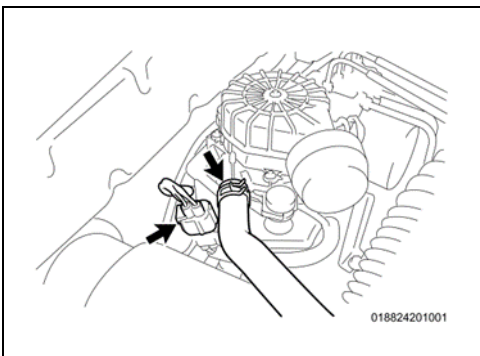

- e. Connect the No. 1 air injection system hose.
- f. Connect the air pump connector.

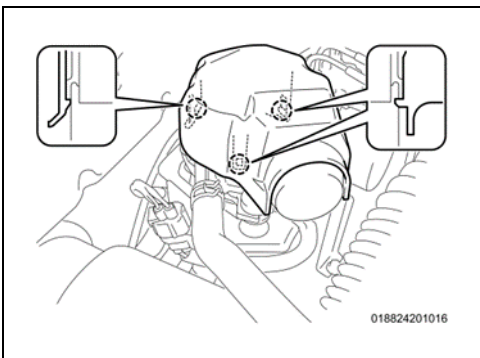

3. INSTALL THE *NEW* AIR PUMP COVER

- a. Install the *NEW* air pump cover with 3 claws.

**Continue to Section IX Air Switching
Valve Replacement on p. 11**

IX. AIR SWITCHING VALVE REPLACEMENT

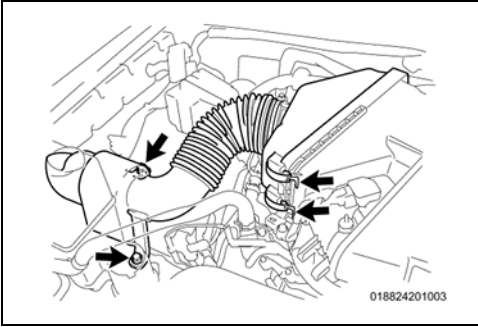

1. **REMOVE AIR SWITCHING VALVE ASSEMBLY**
 - a. Remove the 2 bolts from the No. 2 air cleaner hose.
 - b. Unlock the 2 clamps and remove the air cleaner cap sub-assembly with No. 2 air cleaner hose.

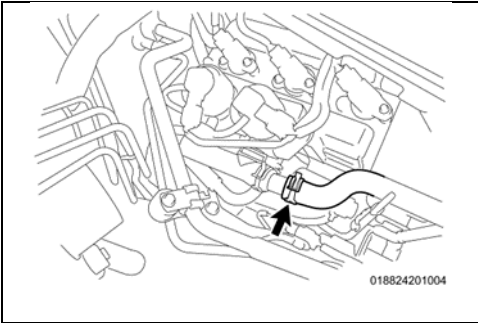

- c. Loosen the clip and disconnect the air tube assembly.

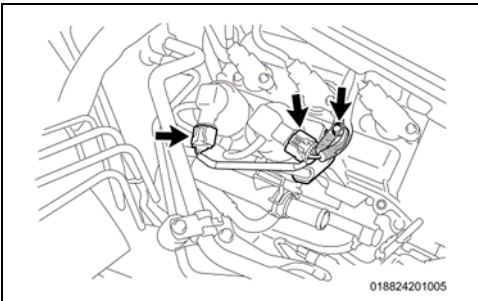

- d. Disconnect the 2 air switching valve connectors.
 - e. Disconnect the wire harness clamp.
 - f. Remove the bolt and the wire harness bracket.

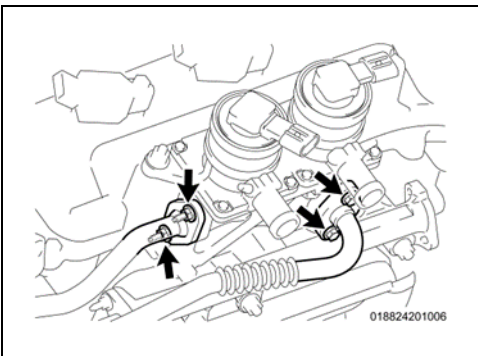

- g. Remove the 2 bolts, disconnect the No. 1 air tube.
 - h. Remove the 2 nuts, disconnect the No. 2 air tube.

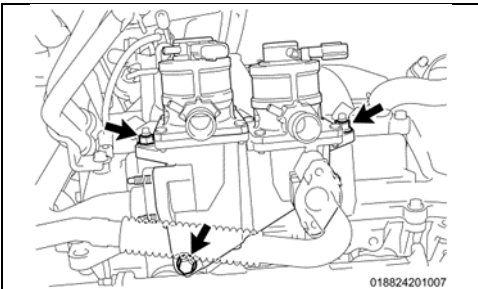

- i. Remove the bolt and 2 nuts.

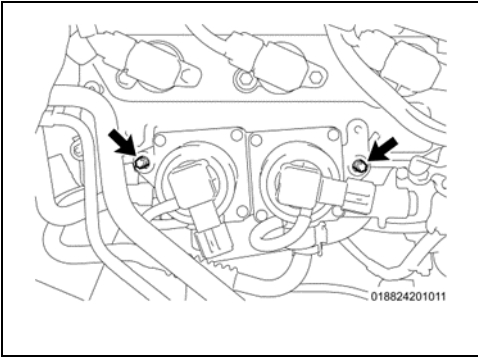

j. Using an E8 Torx socket, remove the 2 studs.

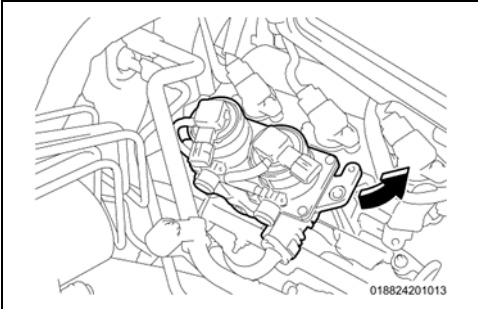

k. Remove the air switching valve assembly.

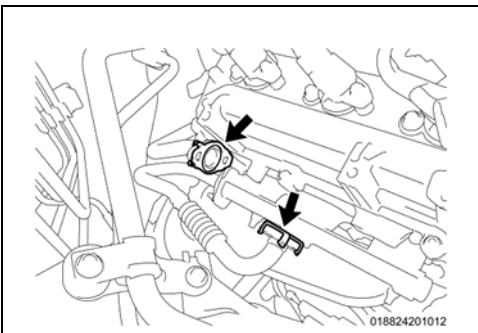

l. Remove the 2 gaskets.

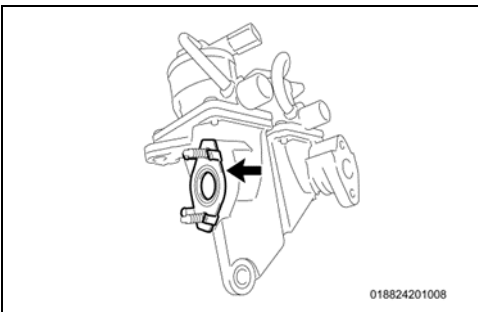

2. INSTALL THE *NEW* AIR SWITCHING VALVE ASSEMBLY

a. Set a *NEW* gasket on the No. 2 air tube side of the *NEW* air switching valve assembly.

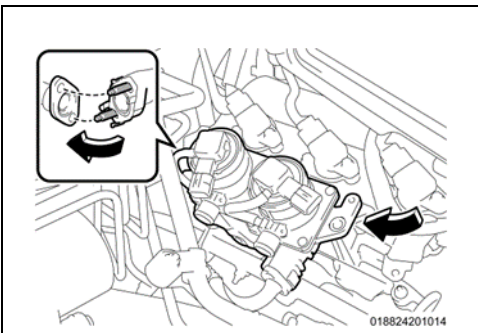

b. Align the position of the air switching valve assembly's stud bolt and insert it into the flange of the No. 2 air tube.

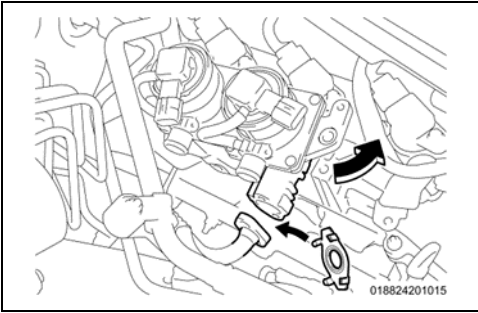

- c. Position the air switching valve assembly to create a gap and attach the **NEW** gasket to the flange of the No. 1 air tube.

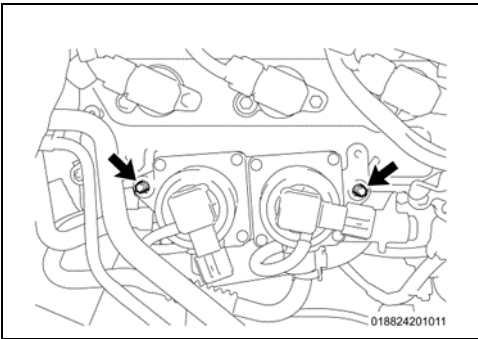

- d. Using an E8 Torx socket, install the 2 stud bolts.
Torque: 10 N·m {102 kgf·cm, 84 in.lbs}

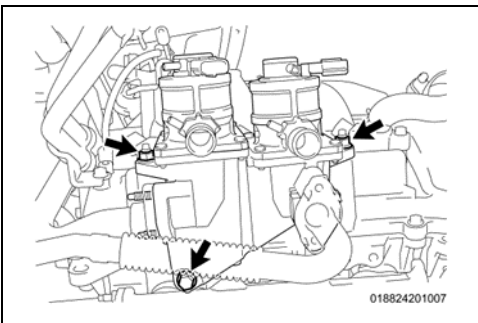

- e. Tighten the bolt and 2 nuts evenly to install the air switching valve assembly.
Torque: 19 N·m {194 kgf·cm, 14 ft.lbs}

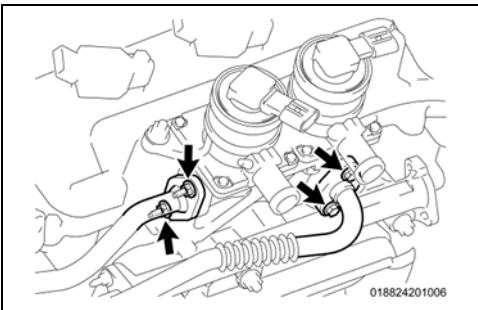

- f. Connect the No. 2 air tube with 2 nuts.
Torque: 10 N·m {102 kgf·cm, 84 in.lbs}

- g. Connect the No. 1 air tube with 2 bolts.
Torque: 10 N·m {102 kgf·cm, 84 in.lbs}

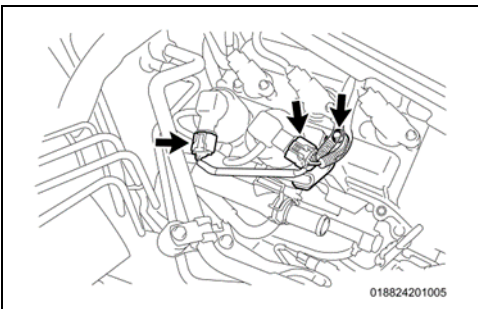

- h. Install the wire harness bracket with the bolt.
Torque: 8.0 N·m {82 kgf·cm, 71 in.lbs}
- i. Connect the 2 air switching valve connectors.

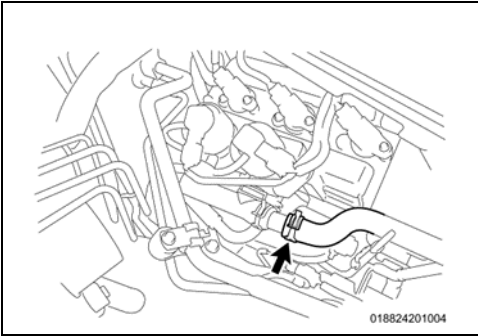

j. Connect the air tube assembly with the clip.

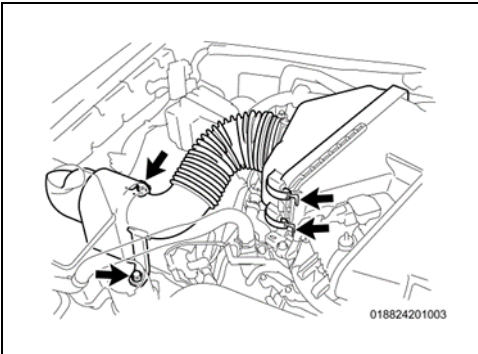

k. Install the air cleaner cap sub-assembly with No. 2 air cleaner hose and lock the 2 clamps.

l. Install the 2 bolts.

Torque: 12 N·m {122 kgf·cm, 108 in.lbs}



2. CHECK FOR DTC'S

- a. Clear current DTC's.
- b. Check for new DTC's.

If any related DTC's are present, diagnose the system to determine the cause.

◀ VERIFY REPAIR QUALITY ▶

- Confirm that no DTC's are present.

If you have any questions regarding this update, please contact your regional representative.

10. APPENDIX

A. PARTS DISPOSAL

In accordance with Federal law, please make sure all recalled parts (original parts) removed from the vehicle are disposed of in a manner in which they will not be reused, **unless requested for parts recovery return.**

B. CAMPAIGN DESIGNATION DECORDER

