

PREVOST

Instruction Sheet

IS-19910H

ELECTRIC FAN DRIVE COOLING SYSTEM CONVERSION WITH DELCO REMY ALTERNATOR

H3 coaches (2PCH...) US10 to GHG17 incl. (B-1721 to J-0184)

REVISION : H THIS DOCUMENT SUPERSEDES PREVIOUS VERSION.
June 17-20 Parts obsolete: 050303, 391028, 562112
Replaced by:
830165 24V RED TELLTALE LIGHT MODULE QTY: 1x
381594 BRACKET, TELLTALE QTY:1x
561540 TAB TERMINAL, ST,16-14,1/4 INS QTY: 2x
New holes drilled for cooling pack relocation

REVISION : G THIS DOCUMENT SUPERSEDES PREVIOUS VERSION.
Jan 24-20 Mention added stating to disable "Prime"

IMPORTANT NOTE

VEHICLES EQUIPPED WITH OPTIONAL PRIME ENERGY MANAGEMENT SYSTEM

TO PREVENT OVERLOADING THE L.H. SIDE ALTERNATOR, IT IS VERY IMPORTANT TO DISABLE « PRIME » SYSTEM ON VEHICLES RECEIVING THIS CONVERSION. PLEASE CONTACT YOUR NEAREST PREVOST SERVICE CENTER TO HAVE THE PRIME SYSTEM DISABLED. A SOFTWARE TOOL IS NEEDED TO DO SO.

Recommended Alternator Conversion Kits

Take note that you can install a Delco Remy 55SI 24V-250A alternator on the engine curbside using one of the following recommended installation kit:

Kit: IS19913 Applicable to: H3 Series, US10

Kit: IS19908 Applicable to: H3 Series, from D-2364 up to J-0184

PREVOST

MATERIAL

Kit **IS19910** contains the following parts:



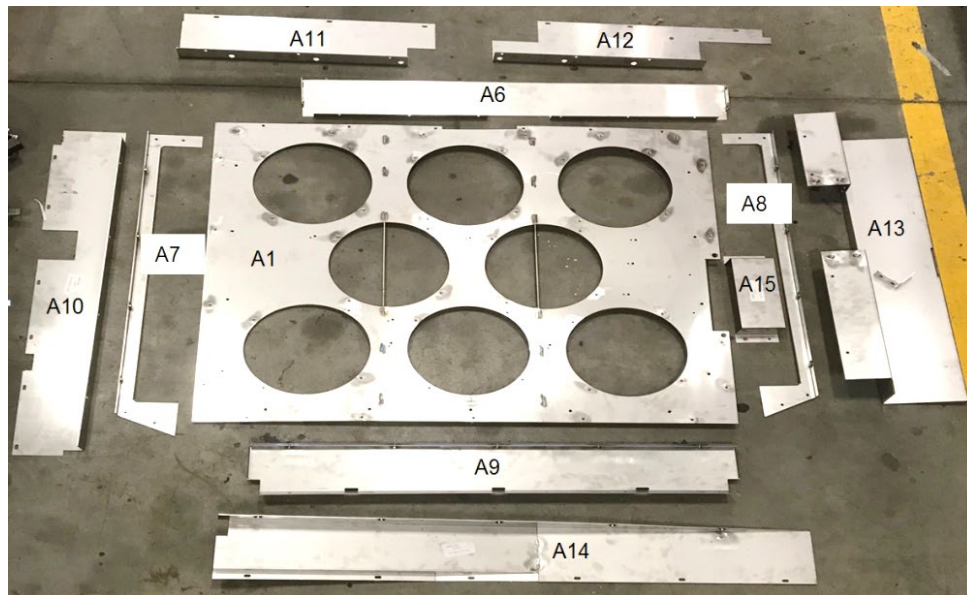



Part No.	DESCRIPTION		Qty
050195	FAN SUPPORT PANEL	A1	1
050200	UPPER SHROUD TRANSITION	A6	1
050201	LEFT SHROUD TRANSITION	A7	1
050202	RIGHT SHROUD TRANSITION	A8	1
050203	LOWER SHROUD TRANSITION	A9	1
050204	UPPER LEFT SHROUD PANEL H3 US10+	A11	1
050229	ELECTRICAL CONNECTOR COVER	A15	1
050206	UPPER RIGHT SHROUD PANEL H3 US10+	A12	1
050213	LOWER SHROUD PANEL H3 US10+	A14	1
050208	LH SIDE SHROUD PANEL H3 US10+	A10	1
050255	RH SIDE SHROUD PANEL & WURTH BOX SUPPORT H3 US10+	A13	1

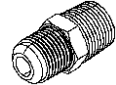
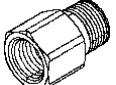
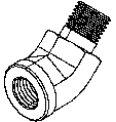
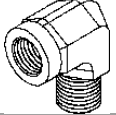
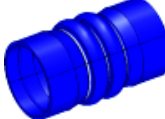

012349	IDLER PULLEY	Mechanical	1
--------	--------------	------------	---













012941	PULLEY, DRIVE	Mechanical 	1
010090	L.H. ENGINE MOUNT	Mechanical 	1
011213	SUPPORT, IDLER + TENSIONER	Mechanical 	1
069893	PULLEY, DELCO REMY ALTERNATOR 10PK 69 DOB	Mechanical 	1
453076	CAP, DUST	Mechanical 	1
506067	1x BELT 10PK1703 ARAMIDE 1x BELT 10PK1703 ARAMIDE (for your spare kit)	Mechanical 	2
510991	TENSIONER, BELT	Mechanical 	1
560720	DELCO REMY ALTERNATOR 55SI 24V-250A	Mechanical 	1
050286	CAC INLET PIPE H3 US10+	Pipe 	1
050406	CAC OUTLET PIPE H3 US10+	Pipe 	1
050414	RADIATOR INLET COOLANT PIPE H3 US10+	Pipe 	1
050288	RADIATOR OUTLET PIPE H3 US10+	Pipe 	1

501027	FITTING, SAE 45° #4FL-Mx1/4NPT-M BR	Fitting 	1
501308	ADAPTER / PIPE FITTING / 1/4NPT-Fx1/4NPT-M BR	Fitting 	1
501329	ELBOW 45° / PIPE FITTING / 1/4NPT-Mx1/4NPT-F BR	Fitting 	1
501332	ELBOW 90° / PIPE FITTING / 1/4NPT-Mx1/4NPT-F BR	Fitting 	1
052366	HOSE 3/8 ID X 61" LONG	hose	1
030096	HOSE, FLEXIBLE - CHARGE AIR Location: engine intake	Hose 	1
550095	HOSE, FLEXIBLE - CHARGE AIR Location: turbo outlet	Hose 	1
531469	HOSE, FLEXIBLE - CHARGE AIR Location: CAC outlet	Hose 	1
531471	HOSE, FLEXIBLE - CHARGE AIR Location: CAC inlet	Hose 	1
052889	HOSE, SILICONE 2 1/2" ID Location : coolant pipes	Hose 	1
053617	HOSE, SILICONE Location : coolant pipes	Hose 	3

21490616	CLAMPS, SPRING LOAD - CHARGE AIR Location: CAC outlet & inlet	Clamps 	8
21490630	CLAMP, SPRING LOAD - CHARGE AIR Location: turbo outlet & engine intake	Clamps 	4
992089	HOSE CLAMP CT CAILLAU 60mm-80mm Location : coolant pipes	Clamps 	16
992081	HOSE CLAMP CT CAILLAU 12-22 Location : coolant filter	Clamps 	4
21185073	MOUNT, ANTI-VIBRATION	Support /bracket 	1
050305	BRACKET, RADIATOR INLET PIPE	Support /bracket 	1
050265	COOLANT FILTER SUPPORT H3	Support /bracket 	1
050214	UPPER RADIATOR SUPPORT H3	Support /bracket 	1
069890	LH LOWER ALTERNATEUR SUPPORT	Support /bracket 	1
069891	LH UPPER ALTERNATEUR SUPPORT	Support /bracket 	1

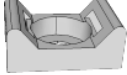
381594	U-SHAPED BRACKET, ALTERNATOR TELLTALE	Support /bracket	1
069205	DECAL, WARNING	Misc. 	2
010111	DECAL, BELT	Misc. 	1
506025	RUBBER EXTRUSION, BLACK	Misc. 	8 ft
380360	GROUND STUD	Misc. 	1
506040	TAPE, ADHESIVE AD1 EPDM CC GY 5/16"X3/4"X25'	Misc.	1
21937327	FILTER, COOLANT	Misc. 	1
012921	GROUND STUD	Electrical 	1
56561540	TERMINAL, TAB		2
561610	CONNECTOR HOUSING, PED WEATHER-PACK 4 WIRES	Electrical 	1
561783	CAVITY PLUG, CONNECTOR	Electrical 	4
22722850	I/O-B MULTIPLEX MODULE	Electrical 	1
23499009-EFD	MCM, PROGRAMMED	Electrical	1

563593	CONNECTOR, WITH END-OF-LINE 120 OHMS RESISTOR	Electrical 	2
563750	FUSE HOLDER, AMG TYPE	Electrical 	1
564520	FUSE, AMG 300A	Electrical 	1
564612	CIRCUIT BREAKER BOX, WURTH	Electrical 	1
565191	FAN, ELECTRIC	Electrical 	8
563533	HAND GUARD, FAN	Electrical 	8
830165	24V RED TELLTALE LIGHT MODULE	Electrical 	1
23498721	FAN DRIVE POWER CABLE, 4600mm	Harness	1
23524934	L.H. ALTERNATOR POWER CABLE – DELCO REMY	Harness	1
23498450	MASTER RELAY TO 300A FUSE CABLE, 300mm	Harness	1
23445869	MCM TO I/O-B INTERFACE HARNESS	Harness	1
23488790	FAN TO RJB INTERFACE HARNESS H3	Harness	1
23490553	VEHICLE INTERFACE HARNESS	Harness	1
068820	HARNESS, FAN DRIVE	Harness 	1

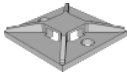
069246	GROUND CABLE, FAN DRIVE	Harness 	1
0610037	CONTROL HARNESS, LEFT ALTERNATOR	Harness 	1
0610035	GROUND CABLE, LEFT ALTERNATOR	Harness 	1
N37749	TIE, NYLON, DOUBLE	hardware 	15
509491	TIE, NYLON LARGE EXTRA STRONG 250 LBS	hardware 	38
504016	TIE, NYLON BLACK (LARGE)	hardware 	58
504013	MOUNT, TIE HOLE 1/4"	hardware 	25
504751	MOUNT, TIE SWIVEL	hardware 	4
504750	MOUNT, TIE TREE	hardware 	1
509490	MOUNT, TIE DOUBLE GRAY	hardware 	15
562679	MOUNT, SQUARE SELF-ADHESIVE BLACK	hardware 	4
500411	WSH FL SS .260X.697X.05 (M6,1/4)	hardware	1
500449	WASHER, FLAT SS .687X1.5X0.078 (M16,5/8)	hardware	1

500482	WASHER, SPLIT LOCK Z050 .506X.873X.125 (M12,1/2)	hardware	1
500942	WASHER, SPLIT LOCK N500 8.1X14.8X2 (M8,5/16,#18)	hardware	4
502570	WASHER, SPLIT LOCK SS 6.1X11.8X1.6 (M6,#12)	hardware	62
502573	WASHER FL SS 6.4 X 12.0 X 1.6 (M6,1/4)	hardware	1
507657	WASHER, BANJO FITTING M14	hardware	8
5001137	WSH FL SS .203X.438X.06 (M5,#10)	hardware	2
5001341	WASHER, FLAT SS 8.4X17X1.6 (M8,5/16)	hardware	7
5001737	WASHER, SPLIT LOCK N500 10.2X18.1X2.2 (M10,3/8)	hardware	4
5001751	WASHER, FLAT N500 10.5X26X2 (M10,3/8)	hardware	10
5001833	WASHER, BELLEVILLE SPR SS 301 6.65X17.4X1.27(M6,1/4	hardware	32
5001868	WASHER, BELLEVILLE SS 8.4X18X2 (M8,5/16)	hardware	4
5001935	WASHER, FLAT SS 10.5X18X1.6 (M10,3/8)	hardware	1
5002008	WASHER, FLAT HARD N500 13X35X5 (M12,1/2)	hardware	1
500998	NUT HEX BR 1/2-13	hardware	1
502837	NUT HEXF STO N500 M8-1.25	hardware	2
502859	NUT HEX NYRT NX500 M10-1.5 G10	hardware	4
5001180	NUT HEX NYRT SS 10-24	hardware	2
5001182	NUT HEX NYRT SS M6-1	hardware	1
5001665	NUT HEX NYRT NX500 M22-2.5	hardware	1
5001761	NUT HEXF NYRT NX500 M12-1.75 G8	hardware	2
5001930	NUT HEXF NYRT NX500 M10-1.50 PC 10	hardware	2
5001983	NUT HEX NYRT NSS M8-1.25	hardware	3
500685	NUT HEX NYRT SS 5/16-18	hardware	1
500119	SCREW, CAP HEX SS NSS M8X1.25X20	hardware	4
500658	SCREW TC PAN PH Z050 10-24X3/4	hardware	11
502719	SCREW, CAP HEX SS NSS M10X20 G8.8	hardware	1
502686	SCREW, CAP HEX SS NSS M6X30	hardware	33
502804	SCREW, CAP HEX N500 M10-1.5X25 G8.8	hardware	8

502848	SCREW TC HEX F N500 1/4-20X3/	hardware	22
5001296	SCREW, CAP HEXFN500 M12-1.75 X 80 CL10.9 PT	hardware	6
5001308	SCR CAP HEXF N500 M10-1.5X40 G10.9	hardware	4
5001643	SCREW, CAP HEXF G500 M8-1.25X25 G8.8 PT	hardware	3
5001697	SCREW, CAP HEX SS NSS M6X16	hardware	62
5001738	SCREW, CAP HEX N500 M8X30 G8.8 FT	hardware	4
5001745	SCREW, CAP HEX N500 M8-1.25X25 G8.8	hardware	2
5001786	SCREW, CAP HEXF AD N500 M12-1.75X30 G8.8	hardware	1
5001799	SCREW, CAP HEXF N500 M10-1.5 X 70 G10.9	hardware	4
5001940	SCREW CAP HEX N500 M12X1.75X140	hardware	2
5002091	SCR CAP HEXF N500 M10-1.5X120 G10.9	hardware	4
504379	RIVET, POP DOME SS OE 3/16X1/4	hardware 	41
504610	RIVET MGL PRDG SS 1/4X5/8	hardware 	14
IS-19910	INSTRUCTION SHEET		1

Other parts or products that may be required:

Part No.	DESCRIPTION
680459	Loctite 404, INSTANT ADHESIVE 9.3gr
680098	LOCTITE 567 THREAD SEALANT 250ML
680038	LOCTITE 243, BLUE THREADLOCKER 50ML

NOTE

Material can be obtained through regular channels.

PROCEDURE

⚠ DANGER

Park vehicle safely, apply parking brake, stop engine. Prior to working on the vehicle, set the ignition switch to the OFF position and trip the main circuit breakers equipped with a trip button.

ELECTRICAL CABLES & HARNESSES DIAGRAM

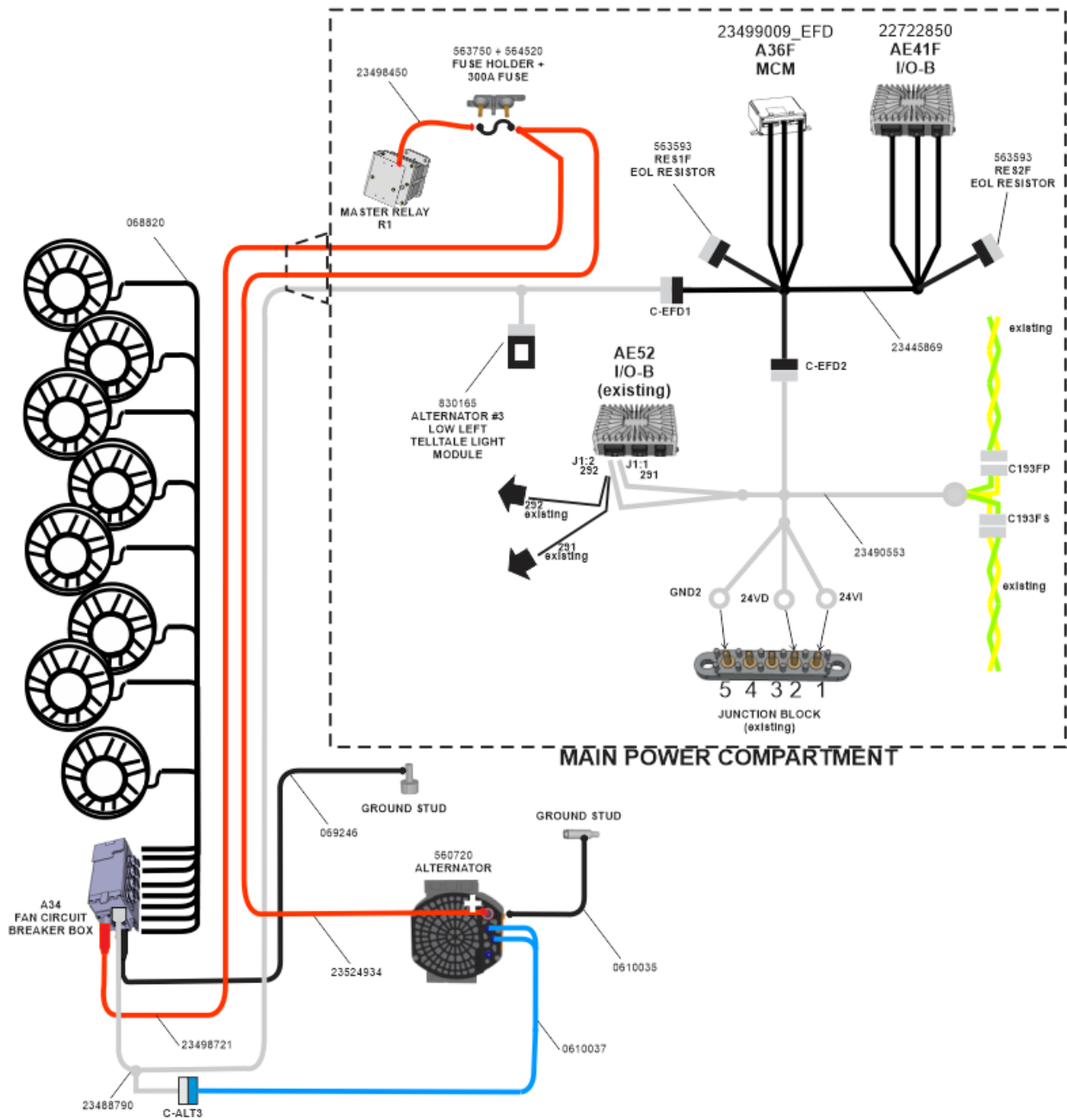

HOSE CLAMP TORQUE (coolant lines and charge air cooler)

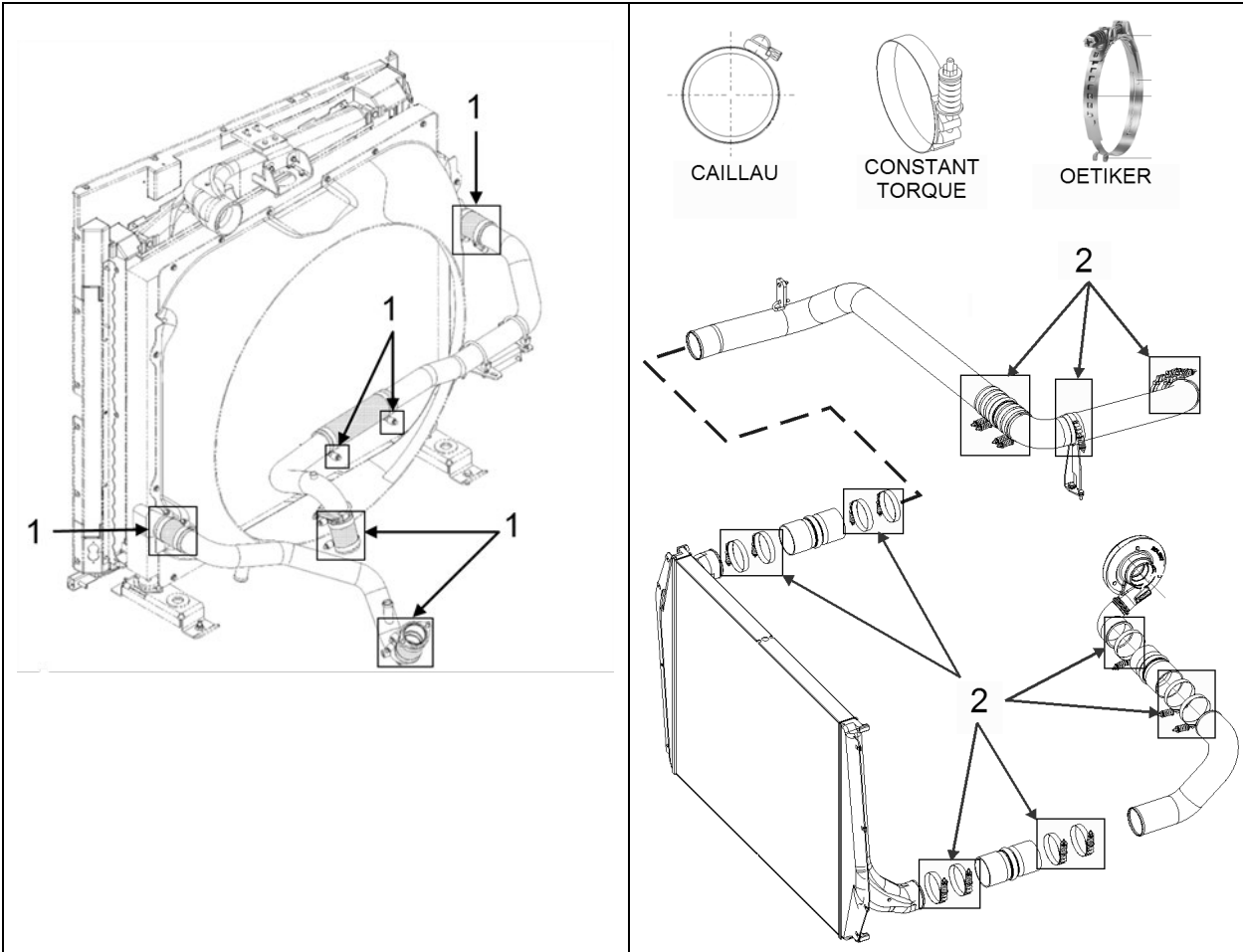

HOSE CLAMPS

No	DESCRIPTION	TORQUE
1 (Ø 2 ½" or lower)	Constant-Torque hose clamps - coolant lines Oetiker hose clamps – Green spring - coolant lines Oetiker hose clamps – unpainted spring - coolant lines Caillau hose clamps - coolant lines	90-100 lbf-in 12-18 lbf-in 8-9 lbf-in 30 lbf-in
2 (Ø 4 ¼")	Constant-Torque hose clamps 4.25in - charge air cooler (CAC)	4.5-5.5 lbf-ft

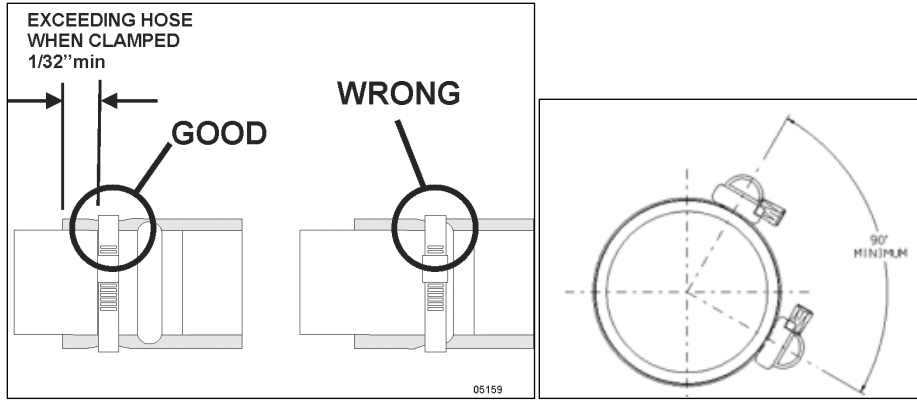

PREVOST

1. In the main power compartment, place the battery master switch to the OFF position. Trip all the main breakers that have a manual trip lever or button (CB2, CB4, CB6, etc...depending on the year model).

2. Remove L.H. side rear fender.

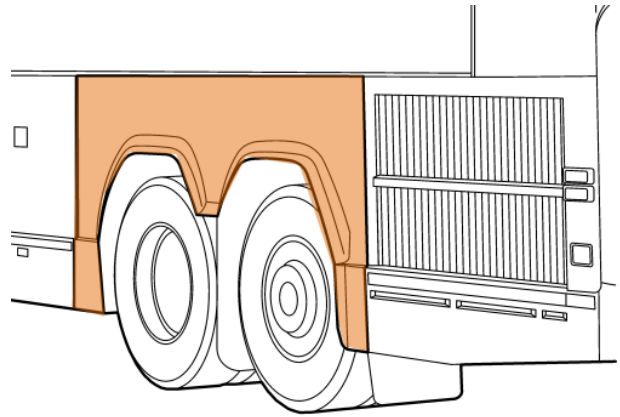

FIGURE 1

Drain the cooling system

3. Connect the coolant extractor. Use the coolant extractor to drain the coolant from the engine. An alternate method is to drain the coolant into a suitable container using the drain hose.

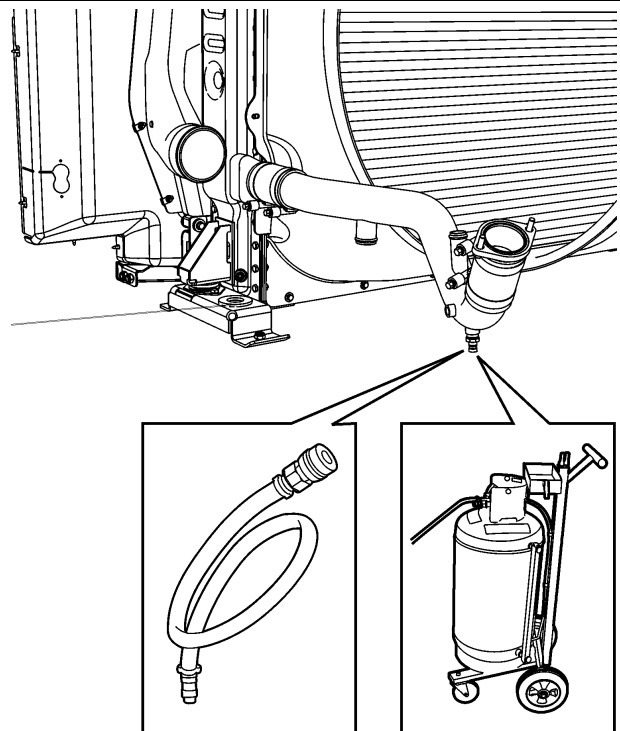

FIGURE 2

4. Unfasten cap screws and remove **access panel** located behind tag axle L.H. side wheel.

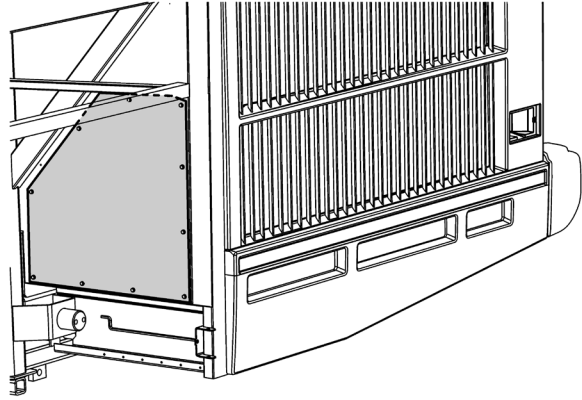

FIGURE 3

5. Open radiator door to access radiator assembly. Unfasten **upper arm assembly**.

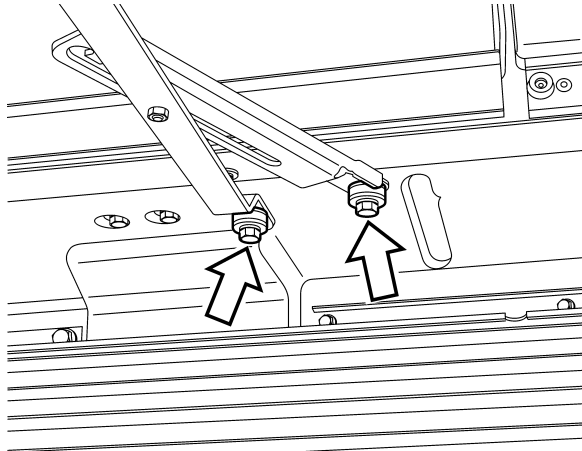

FIGURE 4

6. Remove radiator **sealing frame**.

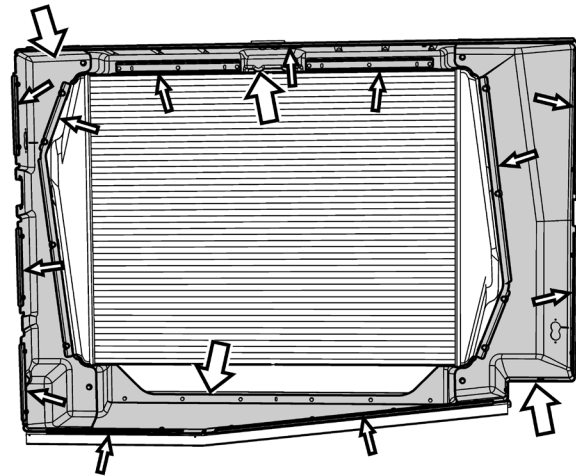

FIGURE 5

7. **Remove clamps** and then break hoses from the front coolant and charge air pipes.

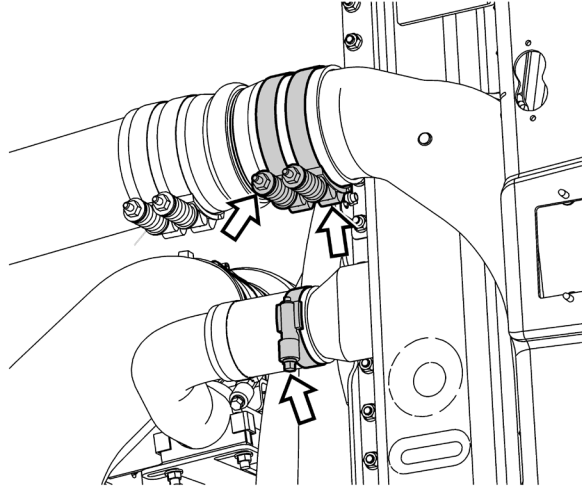

FIGURE 6

8. **Remove rear coolant and charge air hose clamps** then break hoses loose.

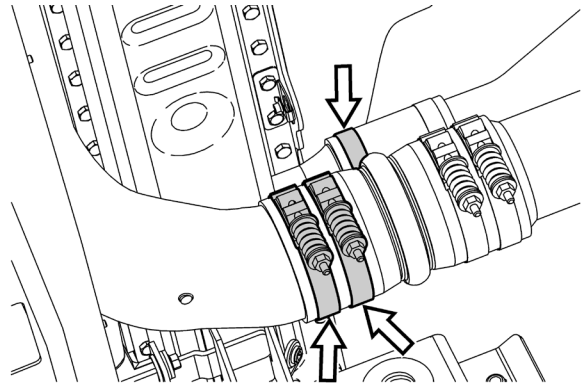

FIGURE 7

9. Remove the upper radiator assembly **support bracket**.

Keep the three small (3) rectangular plates for reuse

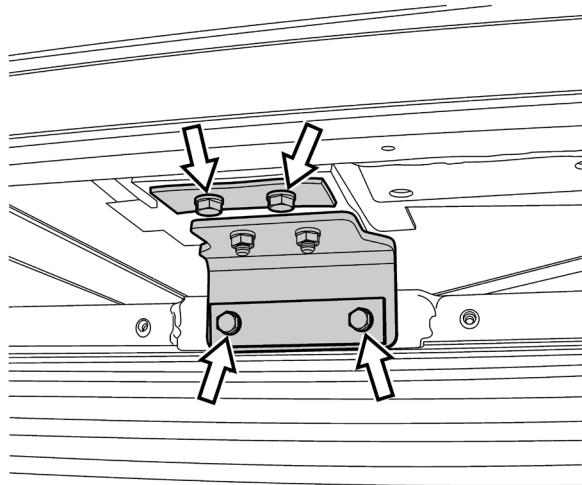

FIGURE 8

10. Remove the lower radiator assembly protector tube.

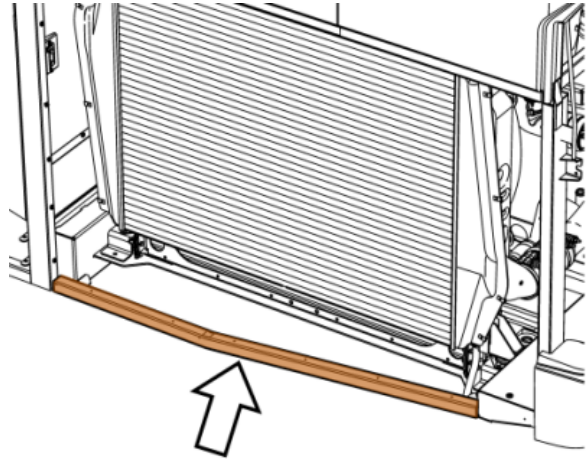
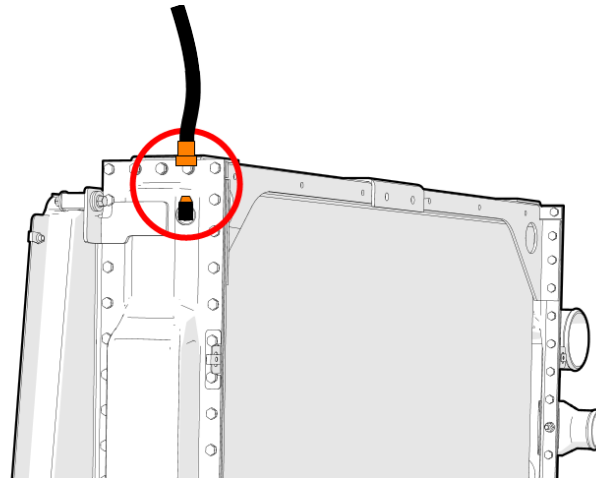

FIGURE 9

11. Disconnect the **radiator vent hose** on top of the radiator.



12. Cut the cable tie and disconnect **electrical connector** from the fan clutch. The remaining connector on the chassis cable will be capped and left in place.

13. Remove fan **drive shaft** fasteners at the fan clutch.

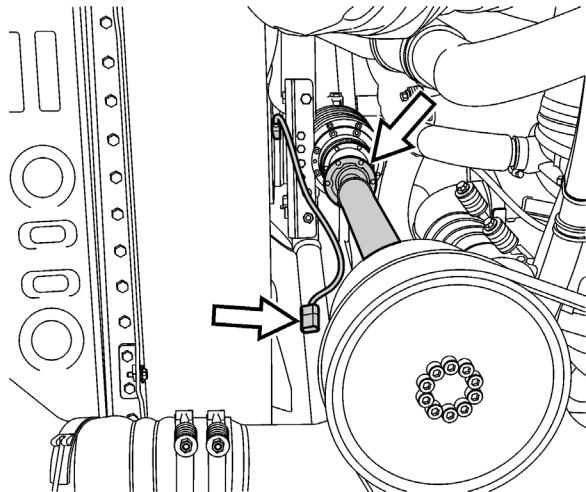

FIGURE 10

14. Open the secondary lock of **connector #561610**. Insert a **cavity plug #561783** in each of the four (4) cavities with the smallest end protruding as shown on the example at right. Close the secondary lock.



FIGURE 11

15. Cap the chassis fan clutch cable with this connector. Secure the connector on the inner wall above the radiator using:

- **1x tree mount #504750**
- **1x nylon tie #504016**



FIGURE 12



FIGURE 13

16. Remove the fan drive casting.



FIGURE 14

17. Unscrew all lower radiator assembly **mounting fasteners** (2 bolts on R.H. side, 2 bolts on L.H. side).

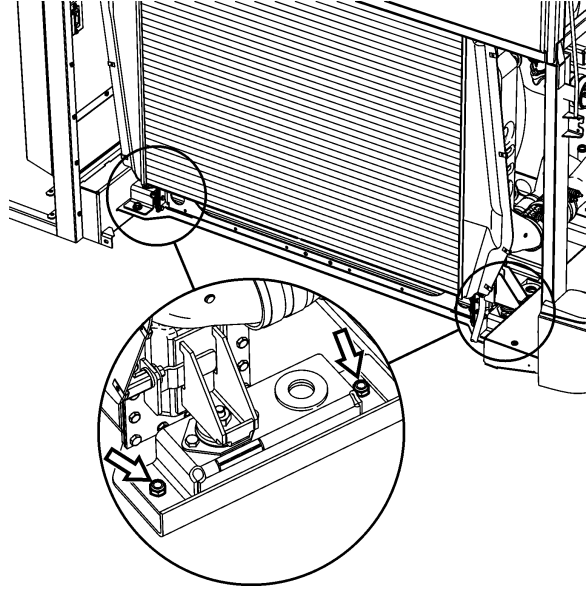

FIGURE 15

18. Position a **forklift** under the radiator assembly that is capable of safely lifting the radiator. With assistance, slide radiator assembly out and onto the forklift. Transfer radiator assembly to a secure location.

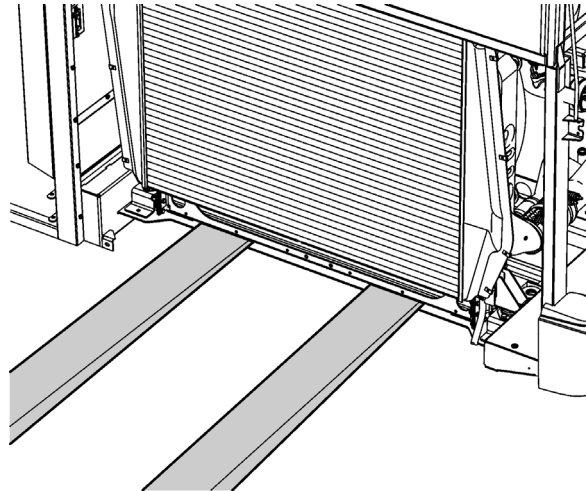

FIGURE 16

19. **Remove** the **tripod** from the radiator/CAC assembly.

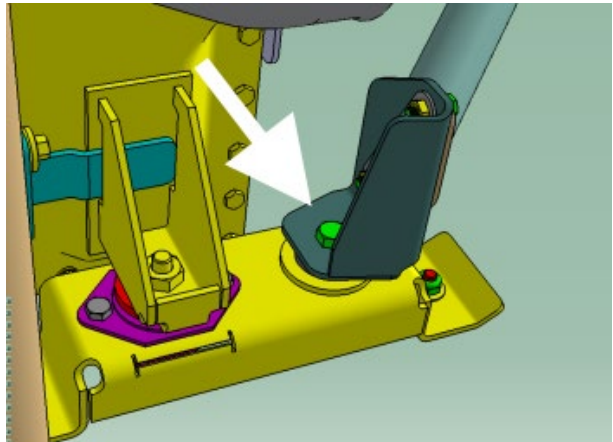

FIGURE 17

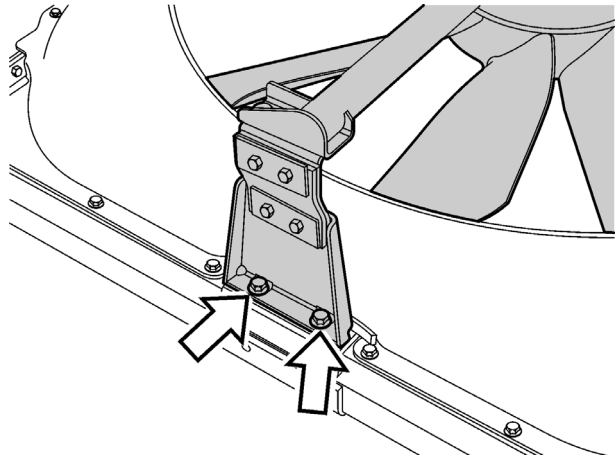

FIGURE 18

20. **Remove** the fan **shroud**.

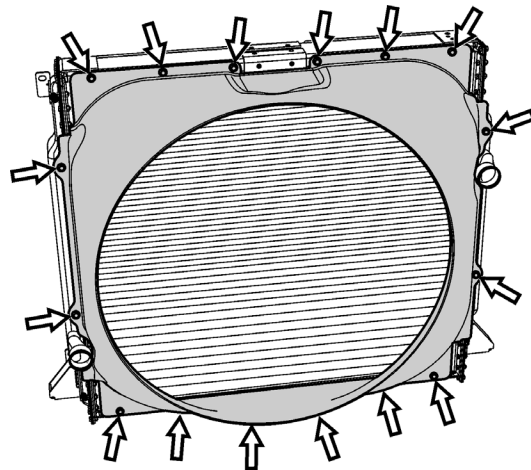

FIGURE 19

21. The new cooling pack arrangement requires being located **four inches** closer to the engine to give the needed clearance for the electric fans. For this reason, **rotate** both the cooling pack assembly **mounting supports 180°** and reinstall.

BEFORE

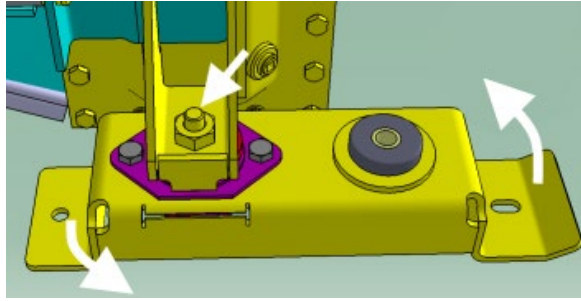

FIGURE 20: MOUNTING SUPPORT IN INITIAL POSITION

AFTER

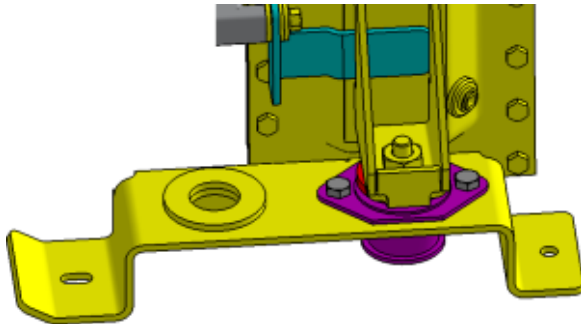

FIGURE 21: MOUNTING SUPPORT AFTER 180° ROTATION

22. Drill two (2) new holes for both cooling pack mounting supports at $\frac{3}{4}$ inch (19 mm) from the previous holes, towards the engine.

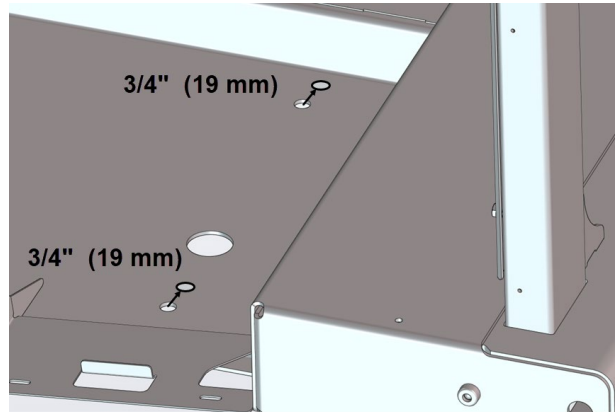

FIGURE 22: NEW HOLES FOR THE COOLING PACK MOUNTING SUPPORTS

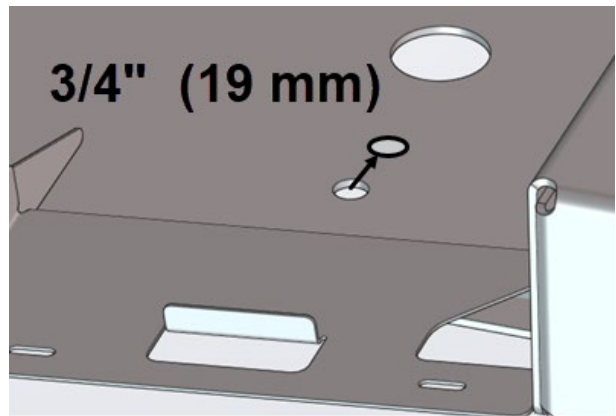

FIGURE 23: NEW HOLE FOR THE COOLING PACK MOUNTING SUPPORTS (DETAIL VIEW)

23. Remove the **rear bumper** (undo three nuts and one attachment plate each side).

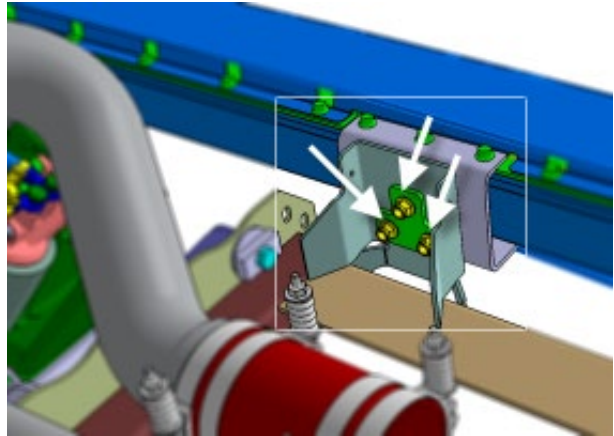

FIGURE 24

24. On the engine hot side, remove the following pipes:

- radiator inlet & outlet pipes
- CAC inlet and outlet pipes

Keep the hose clamps, the flexible hoses for later reuse

Keep the fittings found on the pump inlet pipe for later reuse

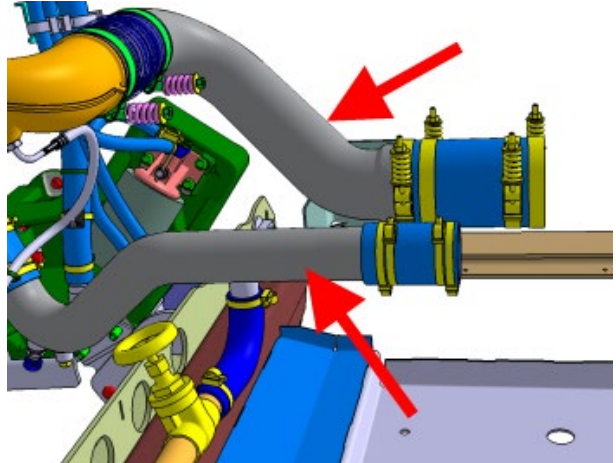

FIGURE 25

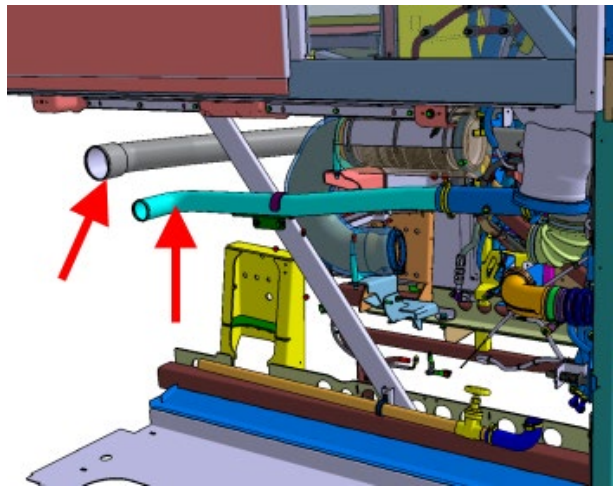

FIGURE 26

25. Remove all the drive belts mounted on the crank pulley.

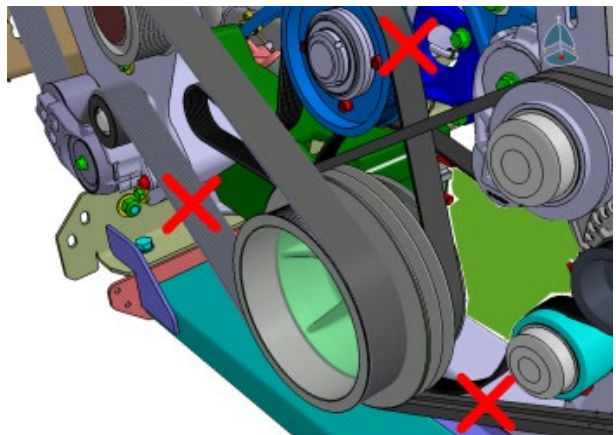

FIGURE 27

26. Remove the drive pulley. Discard the 6 bolts.

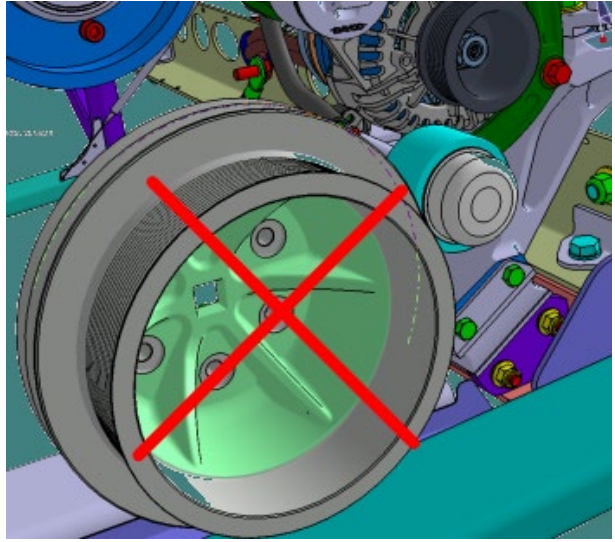

FIGURE 28

27. Remove the rust, clean and prepare the surface on the vibration damper as shown. Make a smooth surface for the pulley that will be reinstalled later on.



FIGURE 29



FIGURE 30

28. Properly support the engine as one of the engine support will be interchanged.



FIGURE 31

29. Remove the two (2) coolant hoses shown on the image. Keep the two (2) banjo fittings for later use.



BANJO FITTING

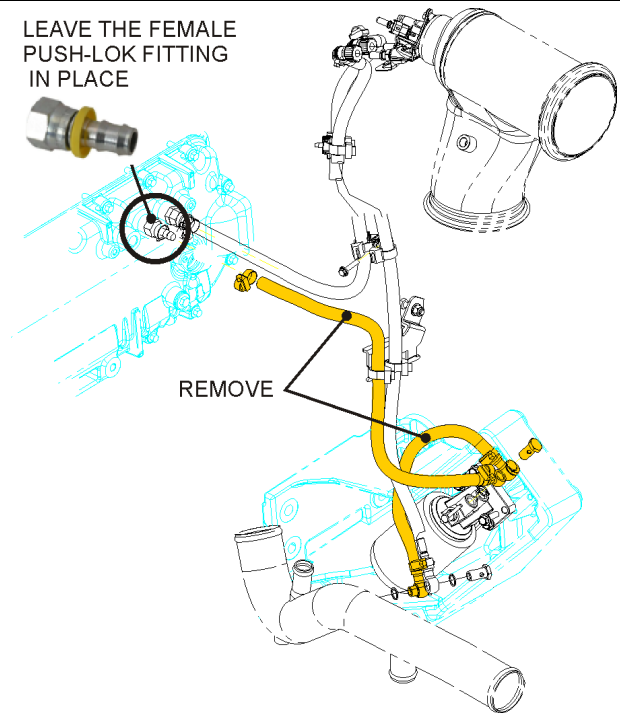

FIGURE 32

30. Remove the L.H. rear engine support on which the coolant filter is installed (10 bolts). Keep the hardware for reuse.

Take note that the water pump belt idler/tensioner assemble will be reused as is. Do not take apart tensioner or idler.

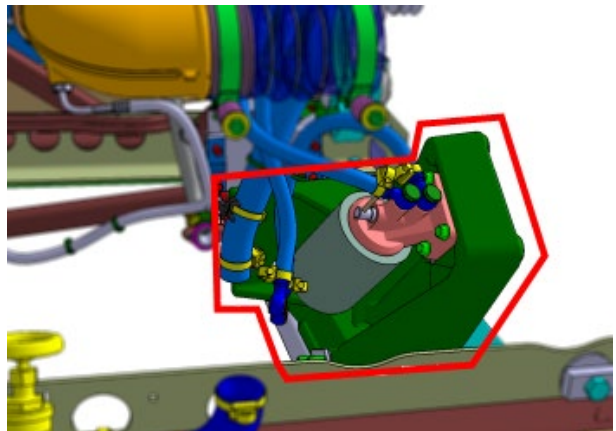

FIGURE 33: L.H. REAR ENGINE SUPPORT

31. Cut the engine cradle rail as shown to increase the clearance between the cradle and the alternator. Carefully work the edge to achieve a smooth finish and contour.

Wear appropriate personal protection equipment.

Protect engine and area with blankets.

Blow area clean when completed.

Apply paint to protect the bare metal

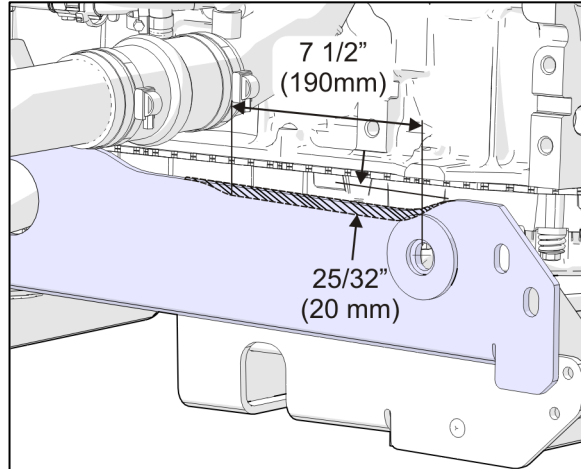

FIGURE 34

32. Remove the water pump idler/tensioner assembly from the former engine mount. To do so, unscrew three (3) bolts at the back of the engine mount.

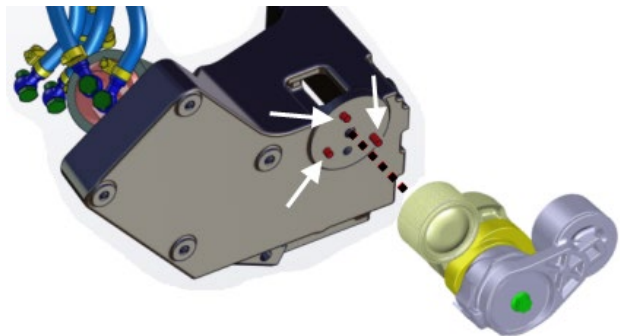

FIGURE 35

33. Reinstall the idler/tensioner assembly as a unit on the new L.H. engine mount #010090.

Mount the idler/tensioner assembly using three (3) cap screws #5001643

Tighten to 14-17 lb-ft

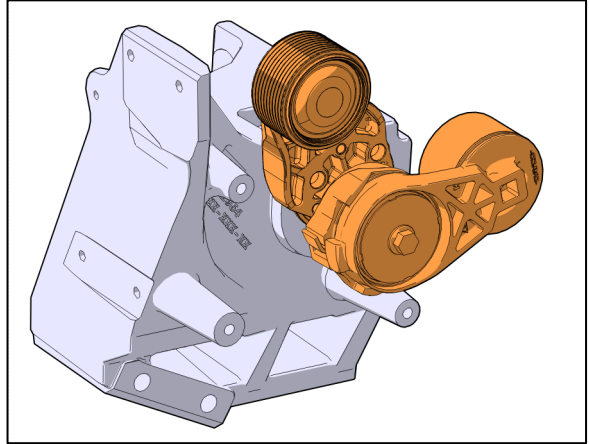

FIGURE 36

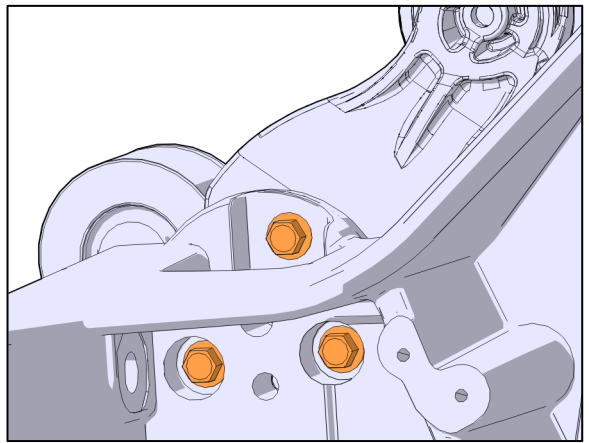

FIGURE 37

34. Install the new engine mount #10090 using seven (7) M14 screws saved from the former engine support with the exception of:

- Ground stud #012921 (1x) and nylon insert NYRT nut #5001665 (1X)
- Isolator cap screw #5001940 (2X)
- Nut #5001761 (2X)

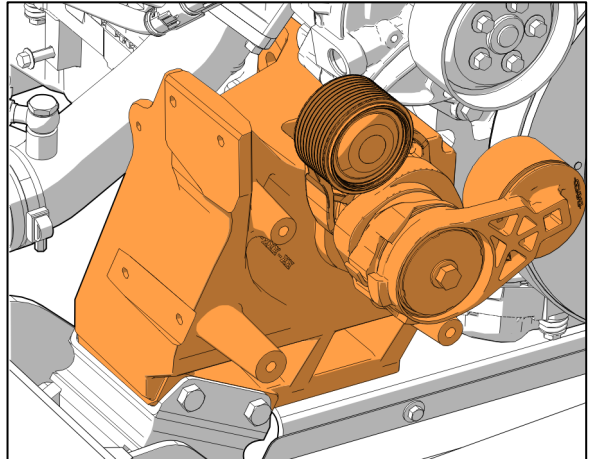

FIGURE 38

**Seven (7) mounting screws torque : 90-94 lb-ft
(128 Nm)**

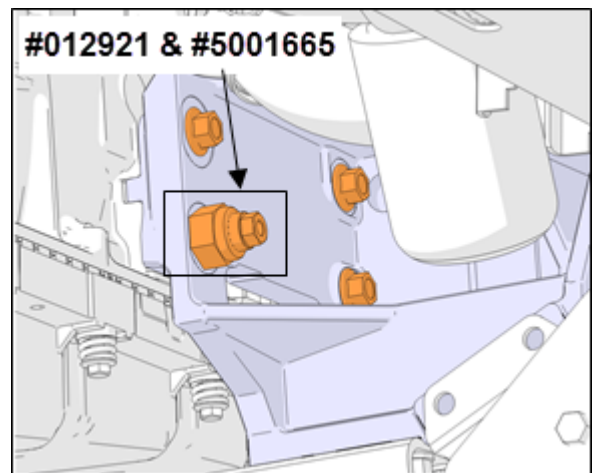

FIGURE 39

**Tighten ground stud to 94 lb-ft
Tighten stud nut to 94 lb-ft**

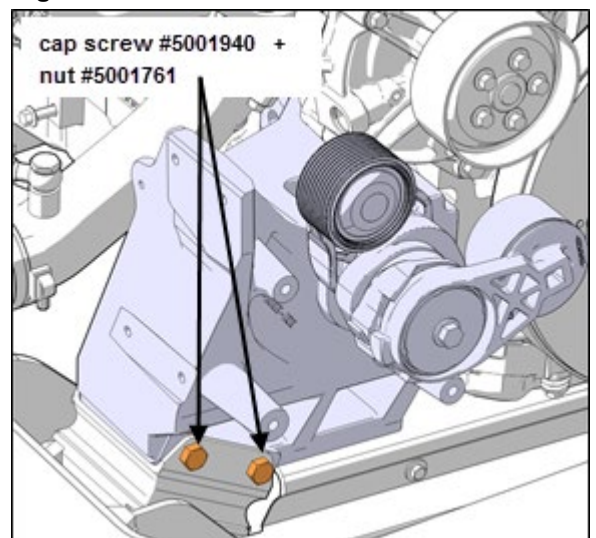

FIGURE 40
Tighten isolator screws to 60 lb-ft

35. Install the new crank pulley using six new bolts #5001296. Use blue Loctite on the bolt threads.

Torque to 26 lb-ft in the numerical order 1, 2, 3, 4, 5, 6, 1

Once done perform a final tightening to the value of 66 lbf-ft.

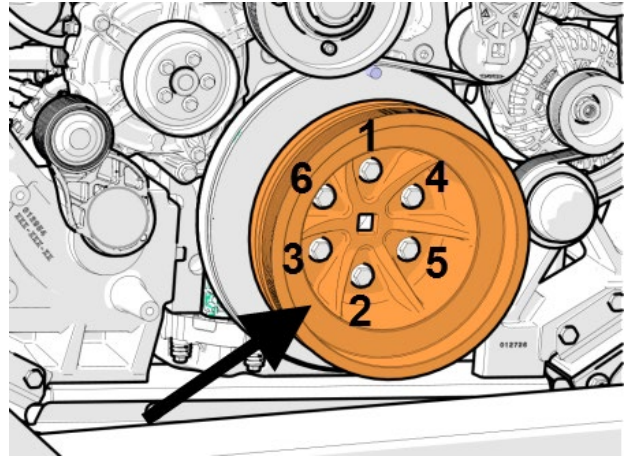

FIGURE 41

36. Reinstall the water pump drive belt.

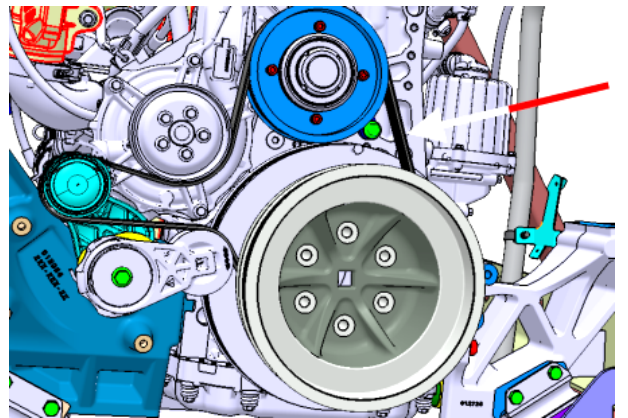

FIGURE 42: WATER PUMP DRIVEBELT

37. Reinstall the AC compressor drive belts.

38. Install **alternator brackets #069890 and #069891**.

Note: Install the upper bracket #069891 with short end towards bumper and long end towards turbo.

Use:

4x cap screws #5001308

Apply blue Loctite

Tighten to **48 lb-ft**

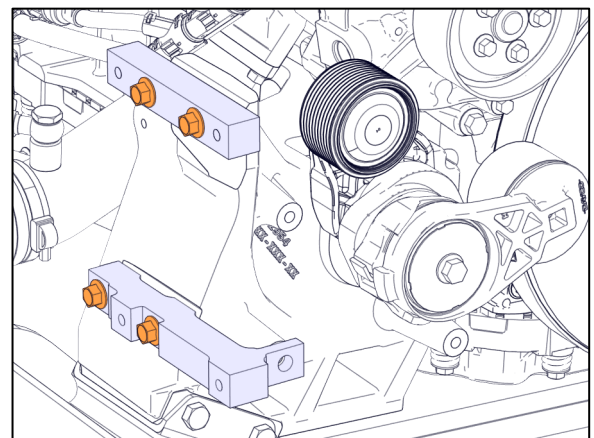

FIGURE 43

39. Installing the LH alternator pulley. Place #560720 alternator flat on a bench with the shaft horizontal.

Required tools:

- 15-16" crowfoot adapter
- 8mm hex bit

Clean shaft and pulley with brake cleaner.

Slide pulley #069893 on shaft by hand.

Hand thread nut on shaft until snug.

Using thin wall 15/16" adapter and 8mm hex bit to block shaft rotation, tighten to **70-80 lbf-ft**.

Never use power tools to install pulley and nut.

Note: Do not apply any pressure to end of the shaft. Internal damage may occur if the shaft is pushed back and turned.

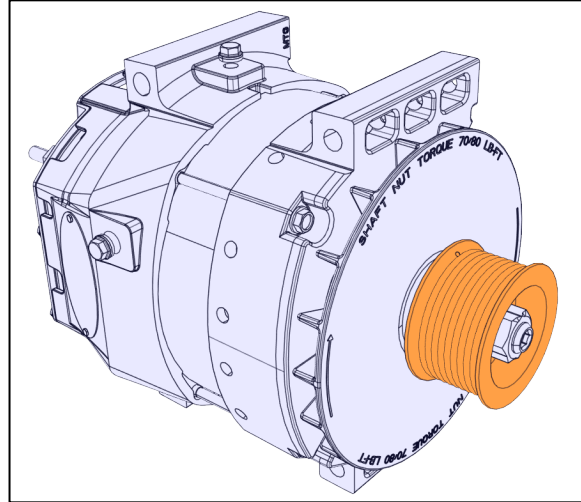

FIGURE 44

40. Install alternator on support with four (4) #5002091 M10x120 screws.

Apply blue Loctite

Tighten to 48 lb-ft

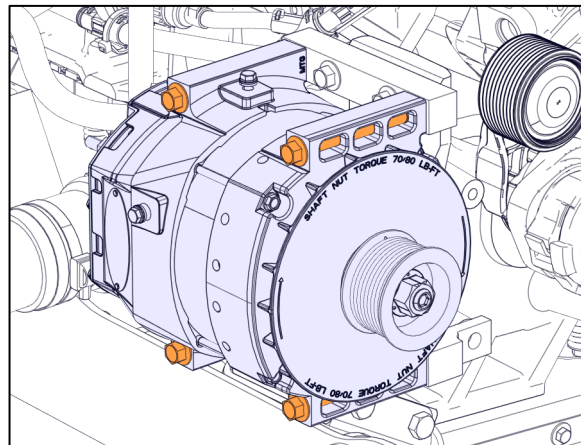

FIGURE 45

41. Install the idler support #011213 using:

3x screws #5001799

Tighten to 48 lb-ft

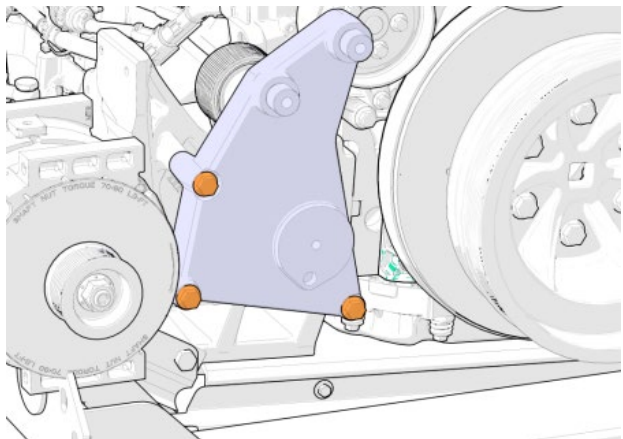

FIGURE 46

-
42. Install the new **idler #012349** with screw #5001786 and washer #5002008.

Tighten to 59 lb-ft

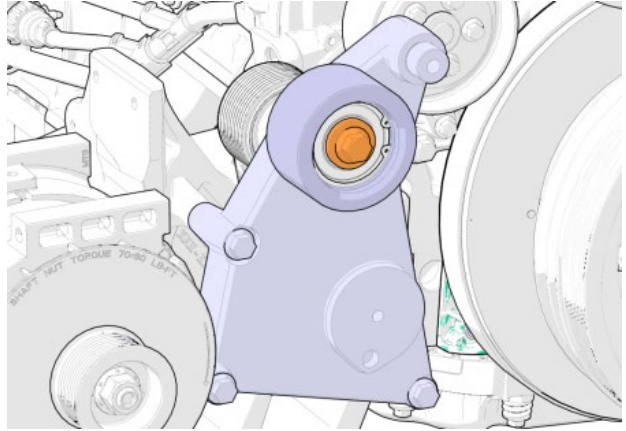

FIGURE 47

-
43. Install the dust cap #453076.

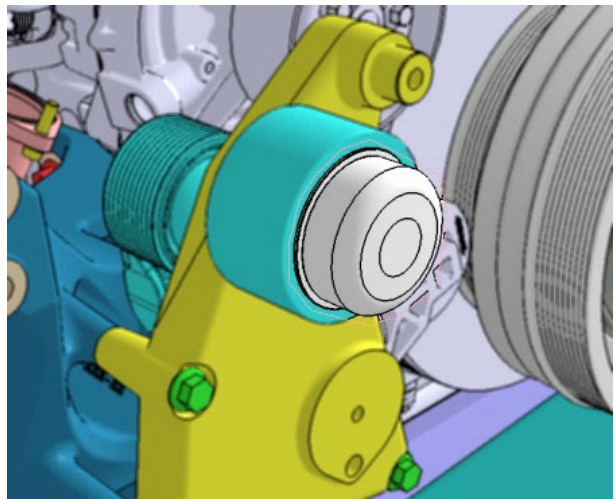

FIGURE 48



FIGURE 49

44. Install the new alternator tensioner #510991. Secure with one **screw #5001799** on which **blue Loctite** is applied.

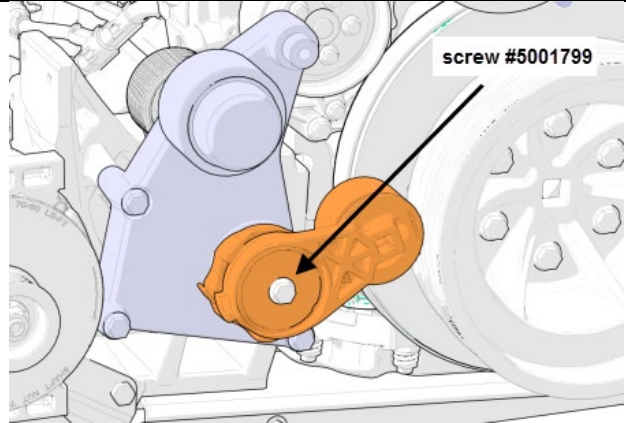

FIGURE 50: Tensioner mounting screw torque : 48 lb-ft

45. Install **belt #506067**. To do so, rotate the automatic belt tensioner using a ½ square drive breaker bar.

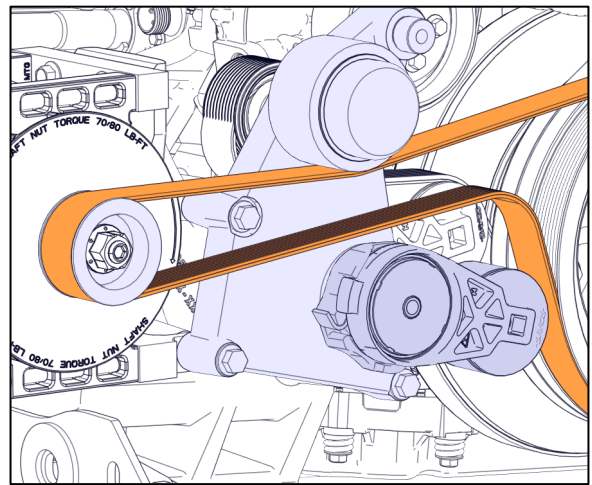

FIGURE 51

46. Remove former belt routing decal and replace with **decal #010111**.

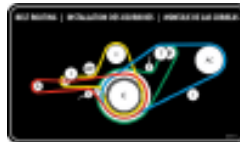

FIGURE 52

47. Install control harness #0610037 on alternator.

Connect circuit **I** to Indicator (I) post.

Connect circuit **S** to Sense (S) post.

Use the following hardware:

- **2x nylon lock nut #5001180**
- **2x washer #5001137**

Tighten to the following torque values:

Sense (S): 25-45 lb-in

Indicator (I): 25-45 lb-in

Apply Color Guard Rubber Coating on the connections.

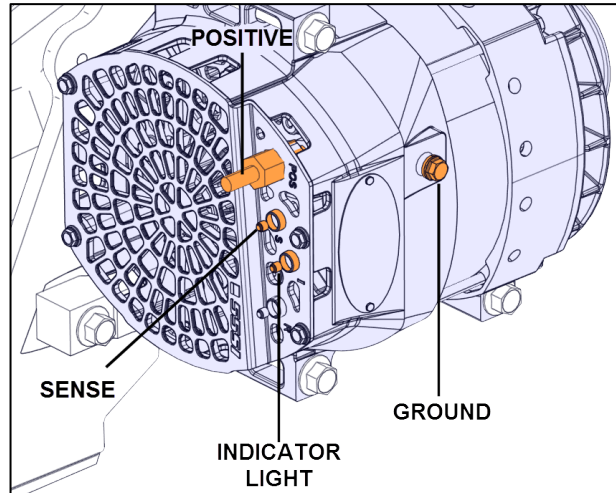

FIGURE 53

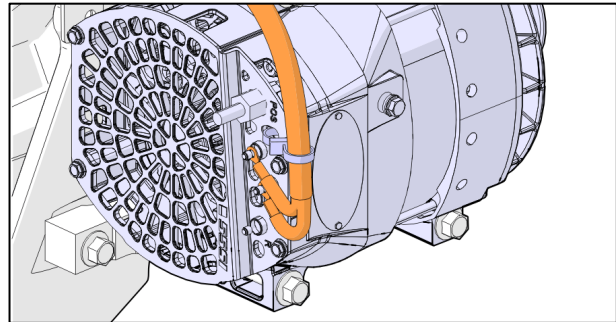

FIGURE 54

48. Perform the “Multiplex Modules Disconnection Procedure Prior to Welding” found in your vehicle Maintenance Manual, Section 00: General.

49. Weld the new coolant filter support #050265 on the engine cradle.

23 1/2 inches from the end of the cradle

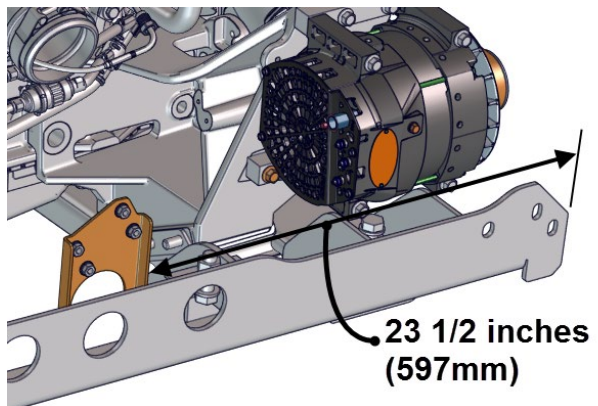

FIGURE 55

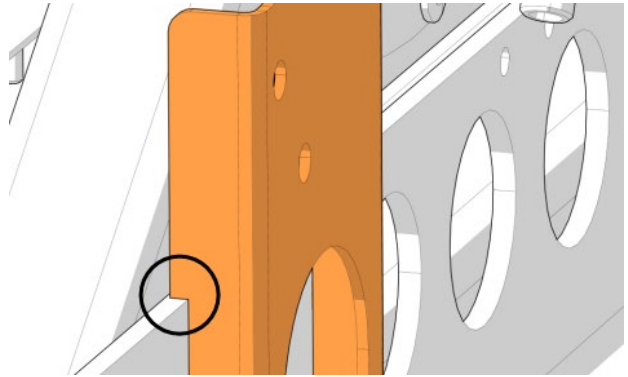

FIGURE 56

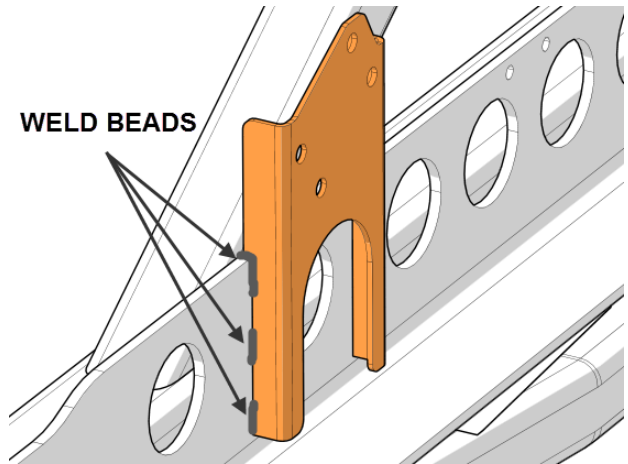

FIGURE 57

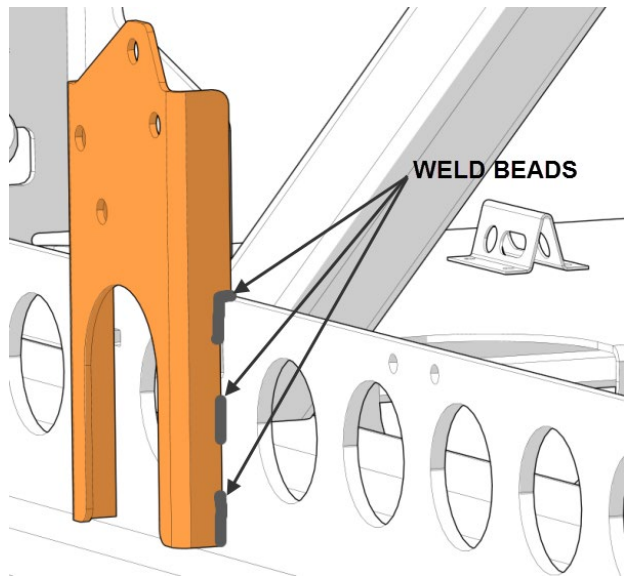

FIGURE 58

50. As a preparation to **welding**, buff the paint to reach bare metal. Weld the **ground stud #380360** centered in the beam and at 14 inches from the beam end.

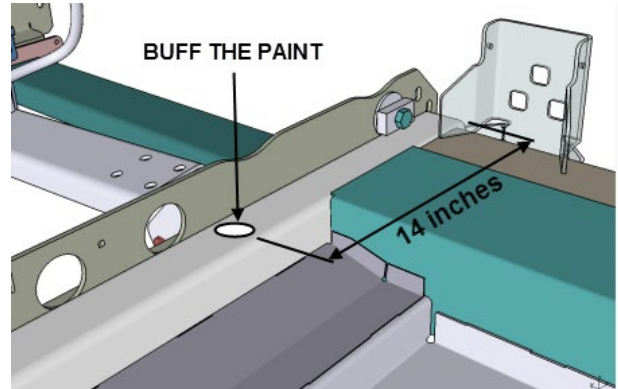

FIGURE 59



FIGURE 60: GROUND STUD #380360

51. Apply black paint to the area surrounding the ground stud and also on the ground stud circular base. **DO NOT** apply paint on the electrical contact surfaces.

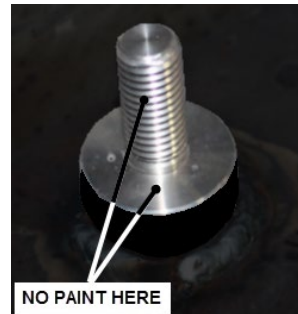

FIGURE 61: GROUND STUD #380360

52. Install a tie mount #504013 with one screw #502686 at the back of the L.H. engine mount.

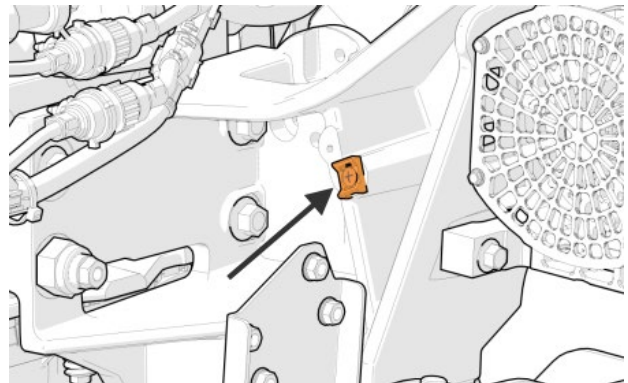

FIGURE 62

53. Install the alternator ground cable #0610035. Use the ground screw and lock washer supplied with alternator **with the addition of a flat washer #500411**.

torque: 50-60 lbf-in

54. Secure the alternator ground cable to the previously installed tie mount using one (1) nylon tie #509491.

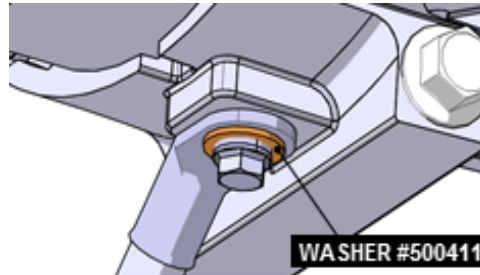

FIGURE 63

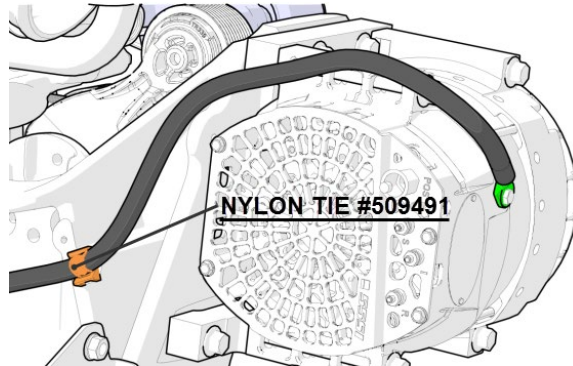

FIGURE 64

55. Secure the alternator ground cable to the previously installed ground stud on the L.H. engine mount.

Use screw #502719 & washer #5001935

Tighten to 20 lbf-ft

Protection against corrosion. Apply Color Guard rubber coating on the ground stud once the ground cable is hooked up.

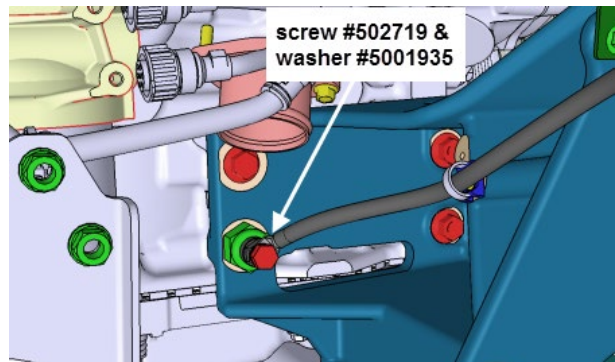

FIGURE 65

56. To the previously installed coolant filter support, install the filter holder recovered from the former installation.

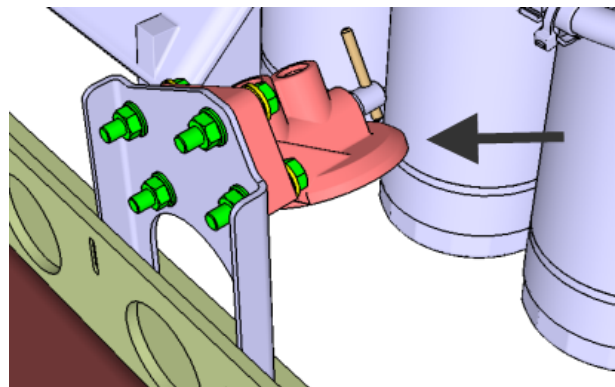

FIGURE 66

57. Install the new coolant filter onto the filter holder. Check the clearance between the filter and the close hose clamps of the coolant pipe leading to the transmission oil cooler.

58. Transfer the drain plug and the coolant extractor quick connect fitting saved from the old pump inlet pipe.

Apply Loctite 567 Thread Sealant prior installation of the fittings

59. Install the new radiator outlet pipe #050288. Reinstall with the flexible hose #053617 and the four (4) hose clamps #992089. Use steel wire to hold the end of the pipe until the radiator is installed if required.

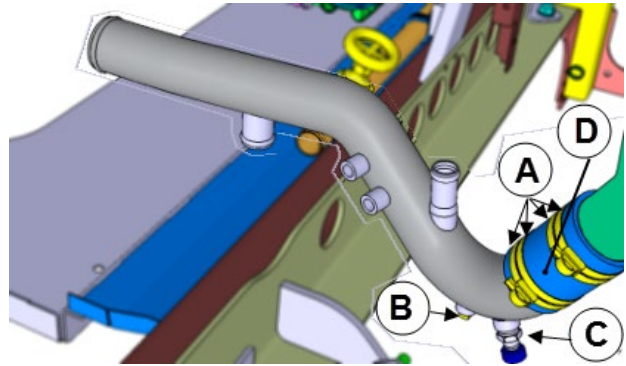

FIGURE 67

A: # 992089 hose clamp (4x)torque: 30 lbf-in

B: drain plug

C: coolant extractor quick connect valve

D: # 053617 silicone hose

60. Reinstall the elbow between the copper heater line and the new radiator outlet pipe.

For proper clamp torque, refer to HOSE CLAMP TORQUE on page 12.

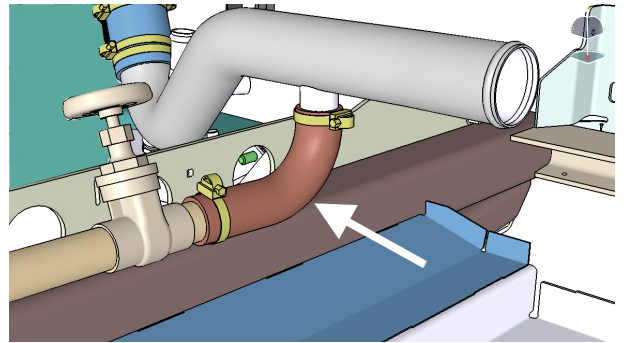

FIGURE 68

61. Using blue flexible hose #052366, prepare two new short hoses for the coolant filter.

a) Cut two sections of blue flexible hose, one **22 inches** long and a second **38 inches** long.

A : hose clamp #992081 (4x)

B: banjo fitting copper washer #507657 (6x)

blue hose 22" long (new)

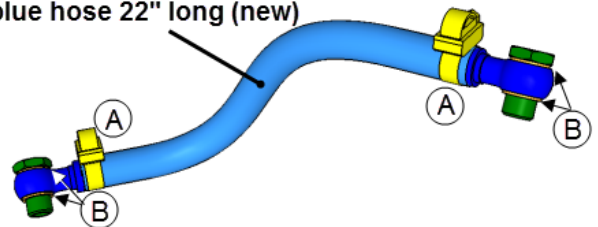

FIGURE 69

b) Use the banjo fittings **recovered** from the previous installation.

hose clamp torque: 30 lbf-in

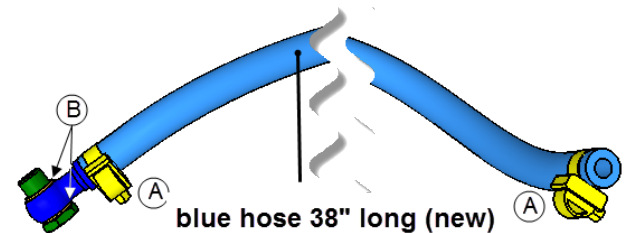

FIGURE 70

62. Install the 22" long and 38" long hoses prepared at the previous step as shown on the images.

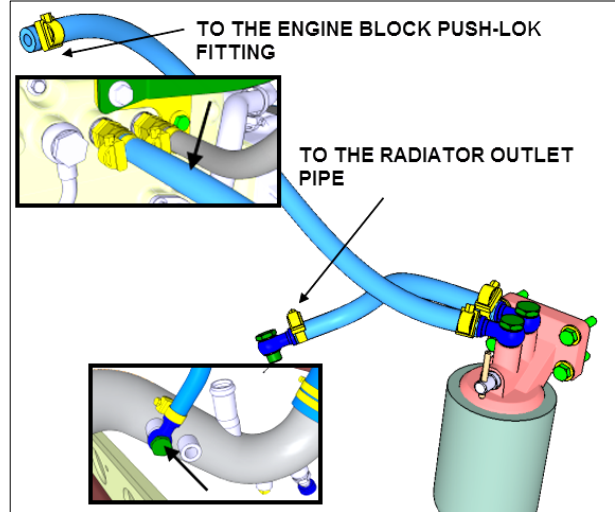

FIGURE 71

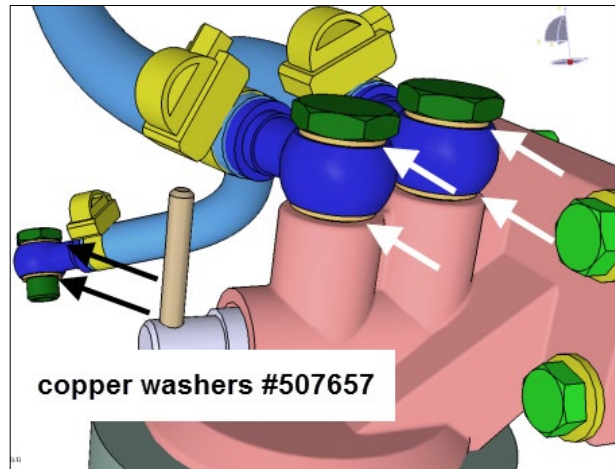

FIGURE 72

63. Connect the DEF injector coolant line return hose to the radiator outlet pipe.

Use two (2) new banjo fitting copper washer #507657

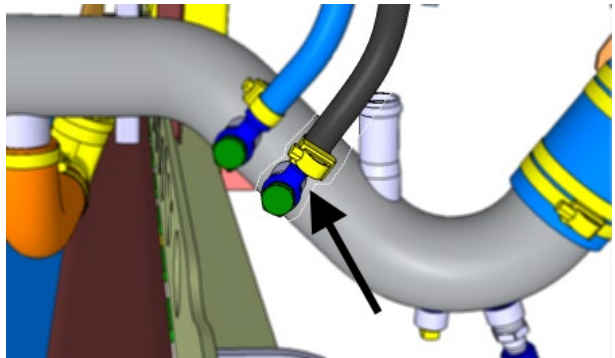

FIGURE 73: DEF INJECTOR COOLANT LINE RETURN HOSE

64. Connect the coolant line coming from the surge tank to the radiator outlet pipe.

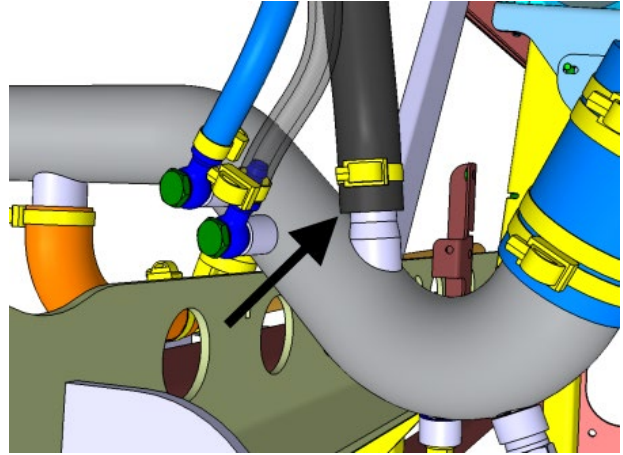
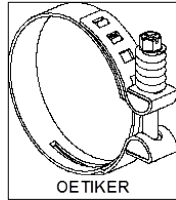
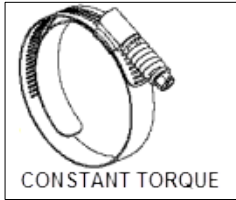

FIGURE 74

TORQUES:

Constant-Torque with spring washers clamps : 90-100 lbf-in

Oetiker clamps – green spring : 12-18 lbf-in

Oetiker clamps – unpainted spring : 8-9 lbf-in

Caillau clamps : 30 lbf-in

65. Secure the coolant hoses together using nylon ties.

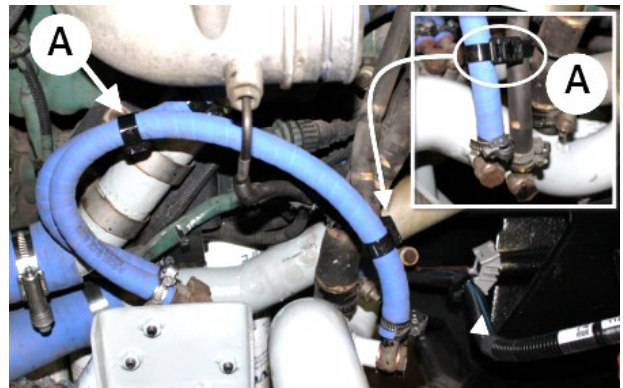

FIGURE 75

A : handcuff nylon tie #N37749 (3x)

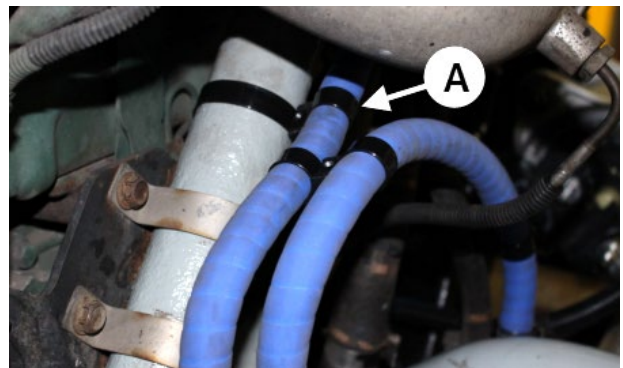

FIGURE 76

66. Secure the coolant hose near the engine block «push-lok» fitting as shown.

B : nylon tie #504016 (1x)

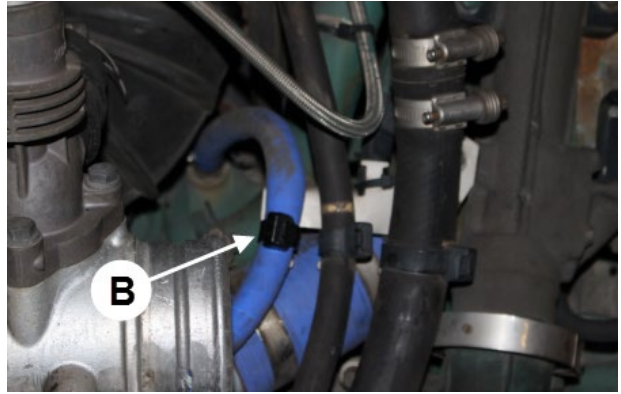

FIGURE 77

67. Hook up the “L.H. alternator power cable” #234524934 to the alternator positive (+) post. Place the flash washer between the cable lug and the nut.

1x nut #500685 torque: 80-125 lbf-in

1x flat washer #5001341

Apply Color Guard rubber coating at the alternator ground (⊥) and positive (+) connections.

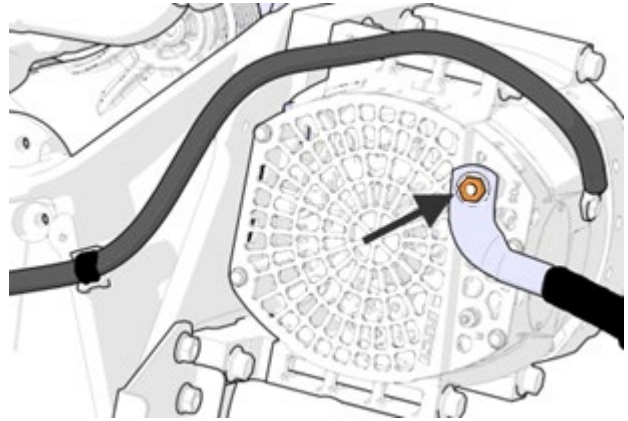

FIGURE 78

IMPORTANT NOTE

Early alternators are provided with a shorter positive stud.

With the short stud, nut #500685 does not thread fully to allow the locking nylon insert to grip on the threads.

In this case, **DO NOT** use nut #500685. Use the nut and lock washer provided with the alternator instead. Tighten to: **80-125 lb-po (9.0-14.0 N-m)**.

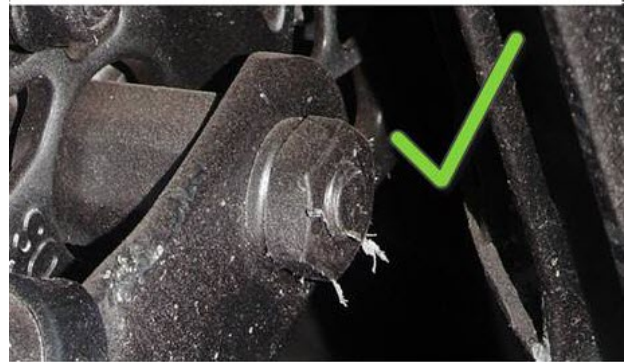
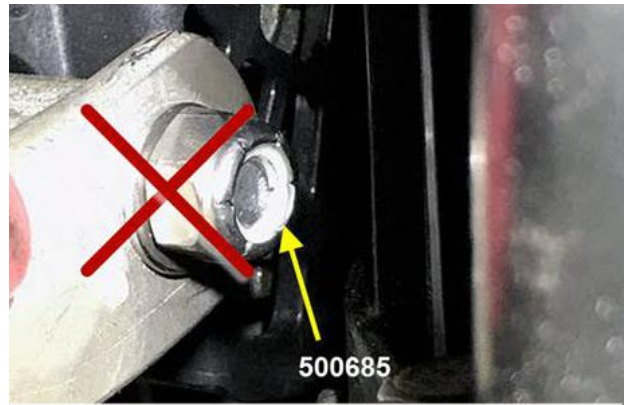

FIGURE 79:

- NUT #500685 DOES NOT THREAD FULLY TO ALLOW THE LOCKING NYLON INSERT TO GRIP ON THE THREADS (UPPER IMAGE)
- HARDWARE TO USE WITH SHORT STUD (LOWER IMAGE)

68. Connect the “fan drive ground cable” #069246 to the ground stud previously welded to the chassis.

A: split lock washer #500482

B: brass nut #500998

C: fan drive ground cable #069246

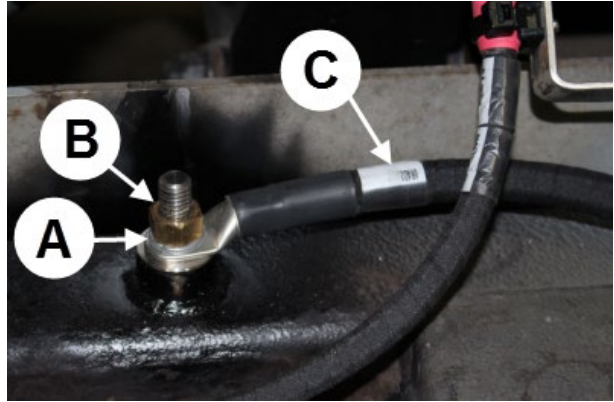

FIGURE 80



FIGURE 81

69. Apply Color Guard rubber coating on the ground stud connection.



FIGURE 82: GROUND STUD WITH RUBBER COATING

70. Install a tie mount #509490 at the location shown on the picture. Secure the tie mount with a rivet.

A: tie mount #509490

B: rivet #504610 (hole diameter: Ø 17/64)

C: nylon tie #509491

D: fan drive power cable #23498721

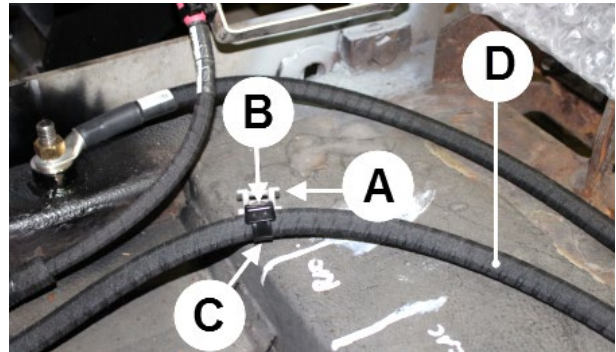

FIGURE 83

71. Secure the “fan drive power cable” #23498721 onto the tie mount using a nylon tie. Make sure to leave **26 inches long** from the tie mount up to the end of the “fan drive power cable” red connector.



FIGURE 84



FIGURE 85



FIGURE 86

72. Install **six (6) tie mounts** to secure the “fan drive power cable” and the “L.H. alternator power cable” as shown on the picture.

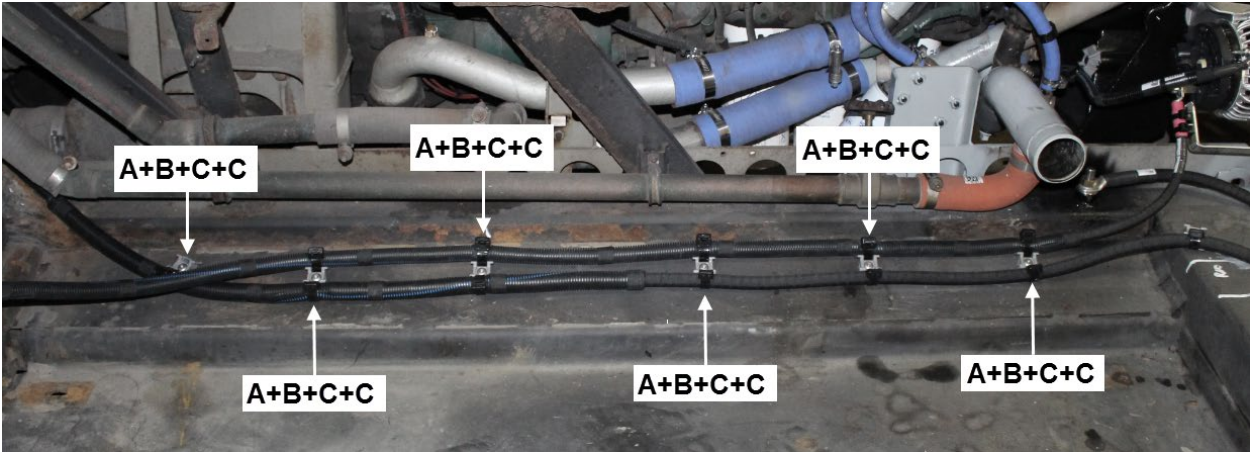

FIGURE 87

A: tie mount #509490

B: rivet #504610

C: nylon tie #509491



FIGURE 88

73. Route the “fan drive power cable” and the “L.H. alternator power cable” up to the main power compartment. Refer to the pictures at right as a guide for the installation.

74. Secure both cables using **seven (5) tie mounts #509490** fixed with **seven (5) rivets #504610** (hole diameter: $\text{Ø } 17/64$). Secure the cables on the tie mounts as previously done with **fourteen (10) nylon ties # 509491**.

A: tie mount #509490

B: rivet #504610 (hole diameter: $\text{Ø } 17/64$)

C: nylon tie #509491

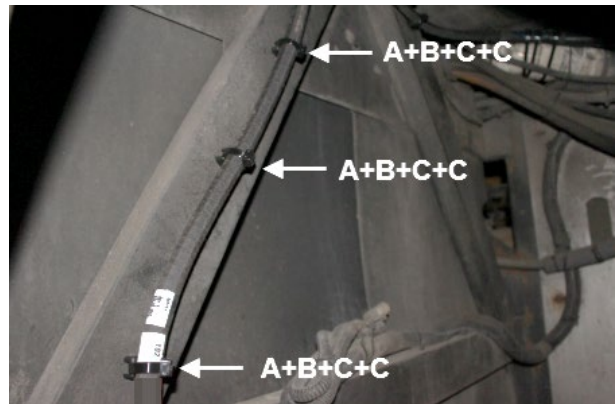

FIGURE 89

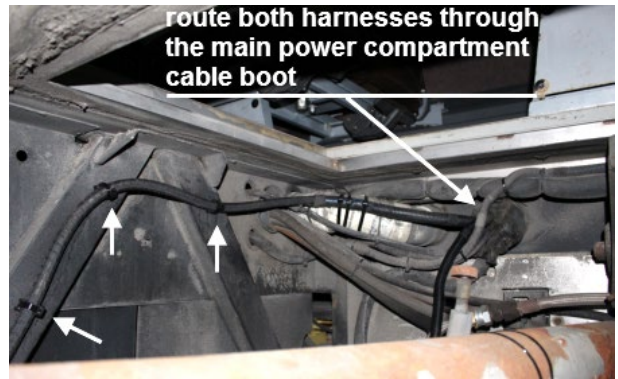

FIGURE 90

75. INSTALLATION OF THE "FAN TO RJB INTERFACE" HARNESS #23488790

- a) Route the "fan to RJB interface" harness #23488790 up to the main power compartment. Secure this harness to the fan drive power cable using nylon ties #504016.
- b) This harness will be connected close to the fan drive power cable, thus it also requires 26 inches of free length.

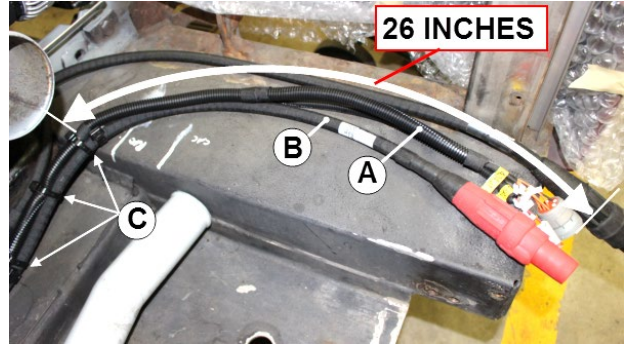

FIGURE 91
A: "FAN TO RJB INTERFACE" HARNESS #23488790
B: FAN DRIVE POWER CABLE
C: NYLON TIES #504016 (23x approx.)

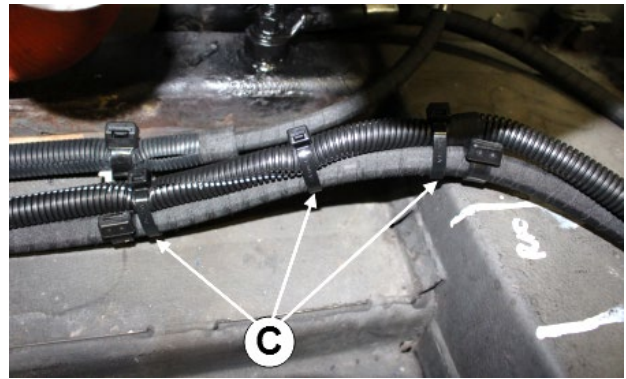

FIGURE 92

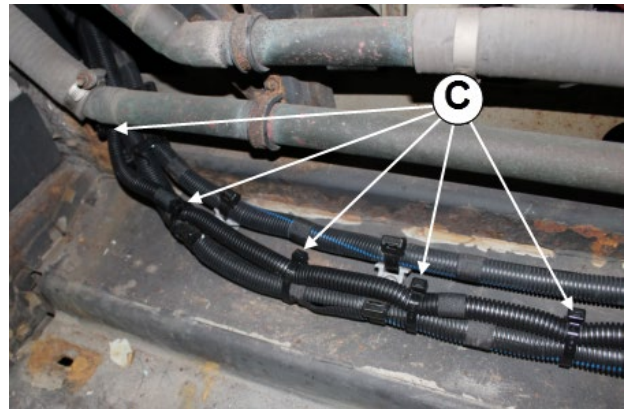

FIGURE 93

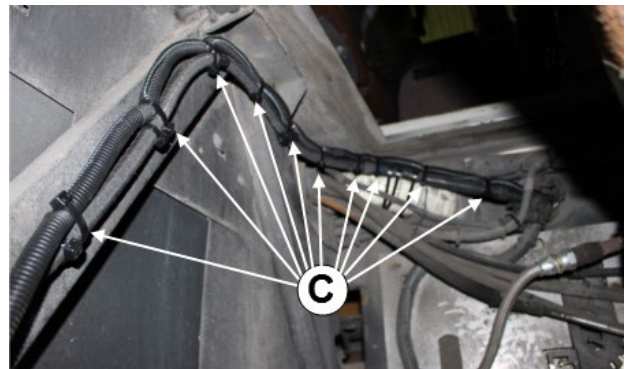

FIGURE 94

76. Connect the new CAC outlet pipe #050406 to the engine intake elbow. **NOTE: in case of interference between this pipe and the ping tank, rotate the ping tank.**

A: #030096 hose (1x)

B: #21490630 spring loaded clamp (2X) (torque: 5 lbf-ft)

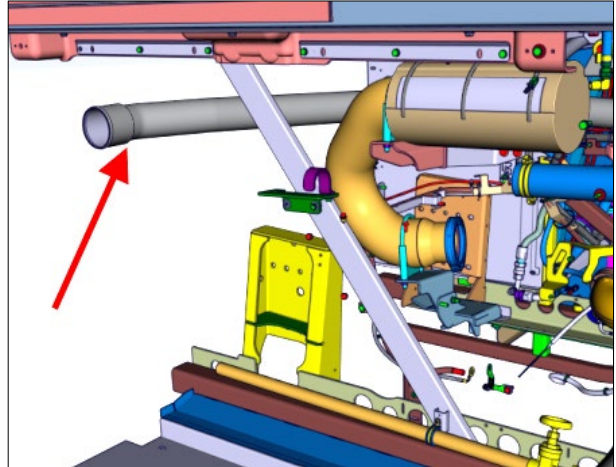

FIGURE 95

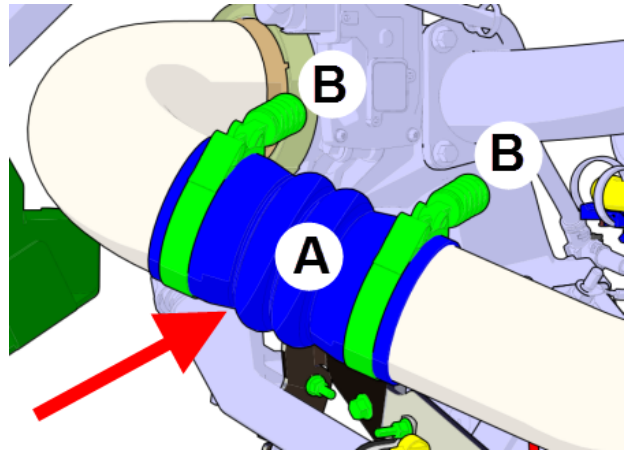

FIGURE 96: CONNECTION AT THE ENGINE INTAKE ELBOW

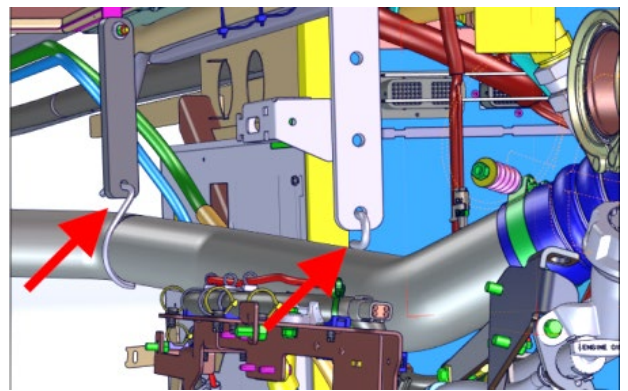

FIGURE 97

77. If your vehicle is equipped with AFSS (Automatic Fire Suppression System), the new CAC outlet pipe #050406 is likely to come into interference with a AFSS extinguishing agent hose (see image) near the end of the pipe that connects with the Charge Air Cooler.

If this is the case, move the hose the other side of the bracket shown, to prevent rubbing between the hose and the CAC outlet pipe.

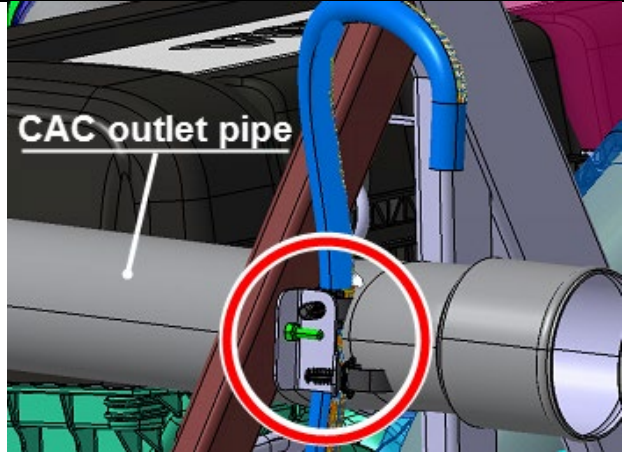

FIGURE 98

78. On the diagonal member, change the existing radiator inlet pipe bracket for the new one #050305. Use the existing hardware.

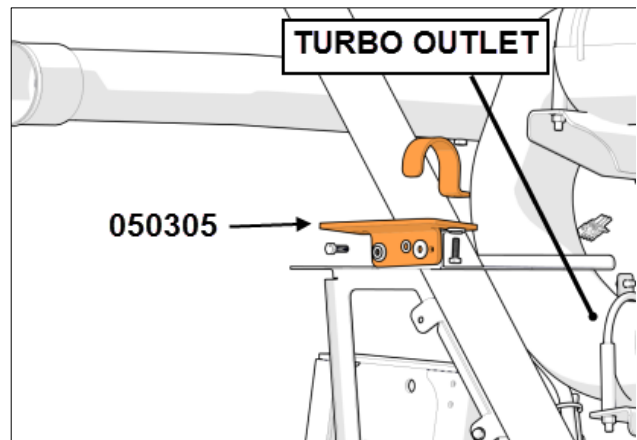

FIGURE 99

79. Install the new radiator inlet pipe #050414.

A: #052889 silicone hose

B: # 992089 hose clamp (4x), torque: 30 lbf-in

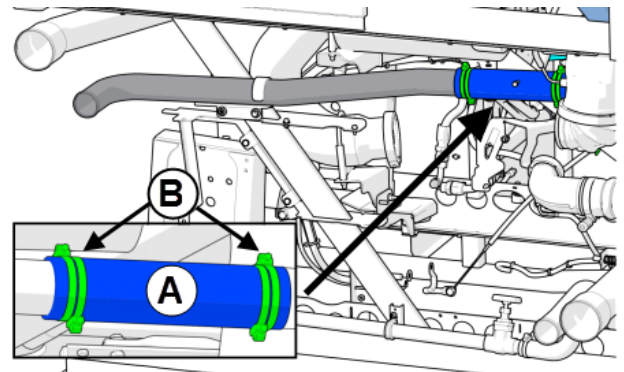

FIGURE 100

80. Install the new **CAC inlet pipe #050286**. Use one new **#550095 CAC flexible hose**. Secure the hose using two (2) spring loaded clamps **#21490630**.

A: #550095 hose

B: #21490630 spring loaded clamp (2X), torque: 5 lbf-ft

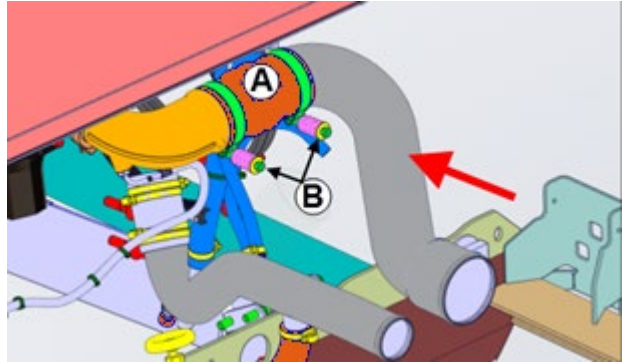

FIGURE 101: CONNECTION AT THE TURBO OUTLET ELBOW

81. Reinstall the cooling pack.

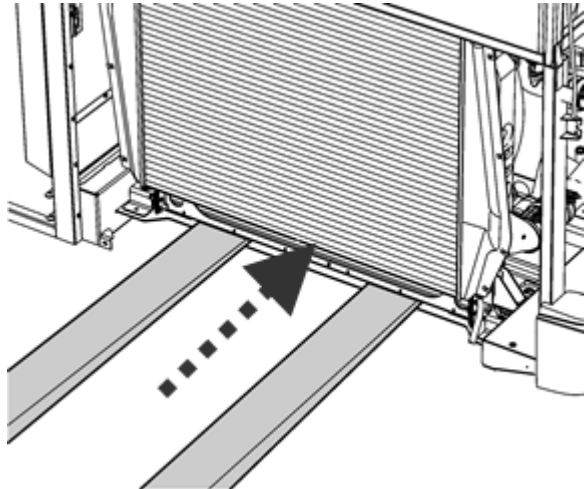

FIGURE 102

82. Place the cooling pack supports over the new holes that were previously made.

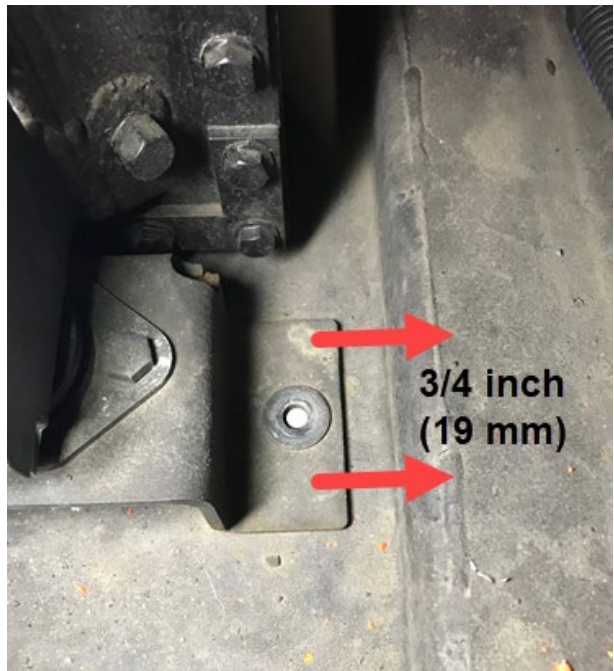

FIGURE 103

83. Secure the cooling pack base with the following parts:

A: 4x screw #502804

B: 8x washer #5001751

C: 4x nut #502859

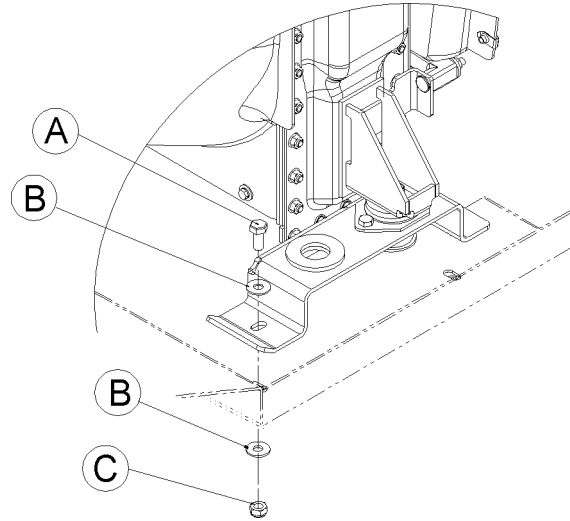

FIGURE 104

84. In case of interference between the charge air cooler and the DPF inlet pipe, loosen the pipe's V-band clamps. Move the pipe in order to increase the clearance, then hold the pipe in place and tighten the V-band clamps.

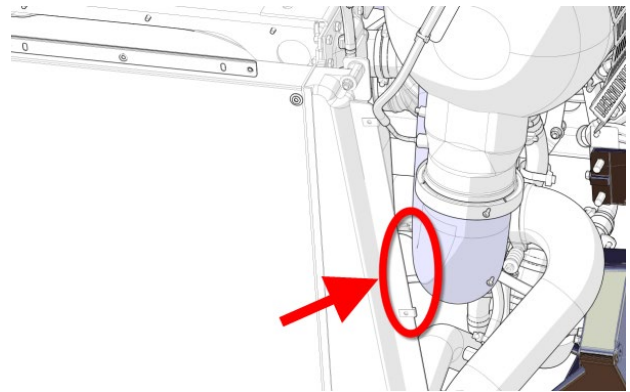

FIGURE 105

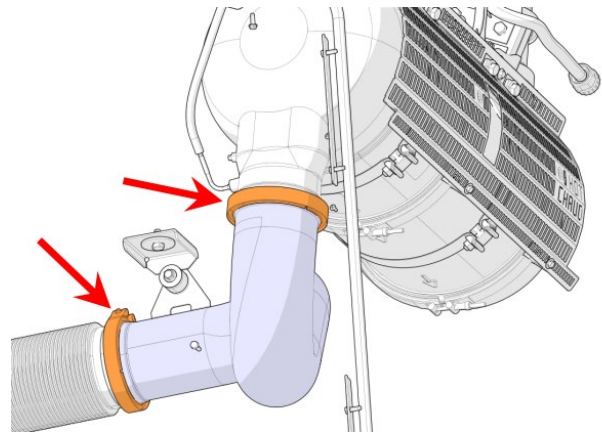

FIGURE 106

85. Using parts #501332, #501308, #501329, #501027, mount the brass fitting assembly shown on the image at right.

Apply Loctite 567 Thread Sealant on the threads

A: #501027

B: #501329

C: #501308

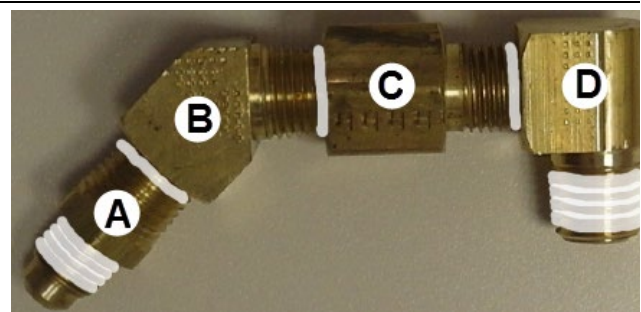

D: #501332

FIGURE 107: BRASS FITTING ASSEMBLY

86. Remove the vent hose fitting found on the radiator.

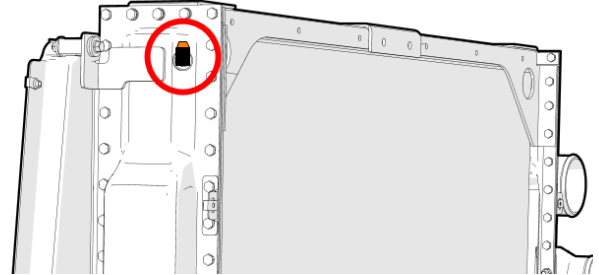

FIGURE 108

87. Install the brass fitting assembly in place of the former vent hose fitting and then connect the **radiator vent hose** to the radiator.



88. Prepare the **cooling pack upper attachment** with the three (3) rectangular plates (see image) recovered from the former installation and the following parts:

A: anti-vibration mount #21185073

B: upper radiator support #050214

C: 2x screw #5001738 , 2x nut #502837

D: 2x screw #5001738 , 2x washer #500942

E: 2x screw #5001745 , 2x washer #500942

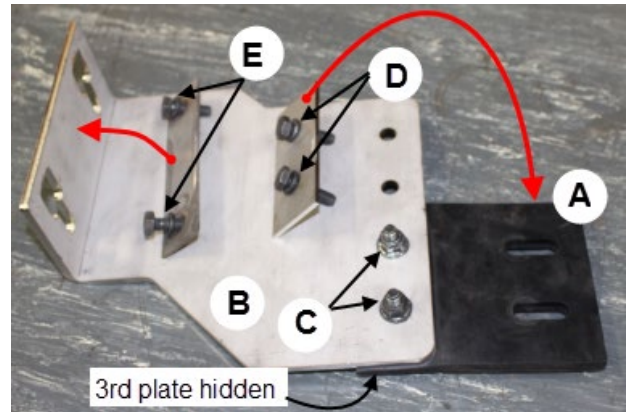

FIGURE 109

One end of the upper attachment is mounted on the radiator frame (image at right)

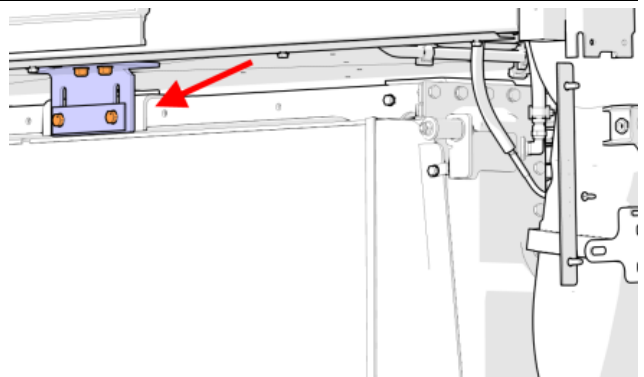

FIGURE 110

Bolt the anti-vibration mount onto the vehicle chassis

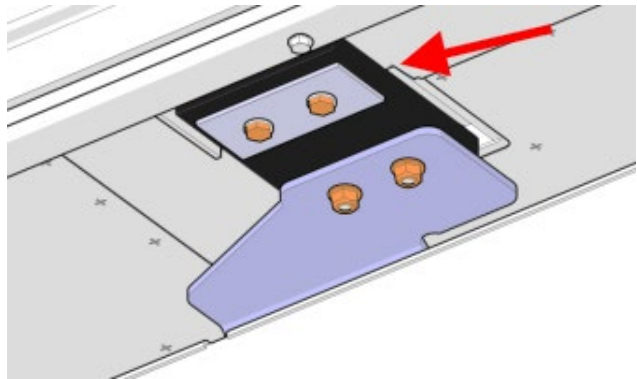

FIGURE 111

89. Reinstall all the blue flexible hoses at the CAC and radiator (at the lower connections of the cooling pack). Install with the following parts:

- A: #21490616 clamp (4x) (torque: 5 lbf-ft)**
- B: #531471 flexible hose**
- C: #053617 silicone hose**
- D: #992089 (4x)**

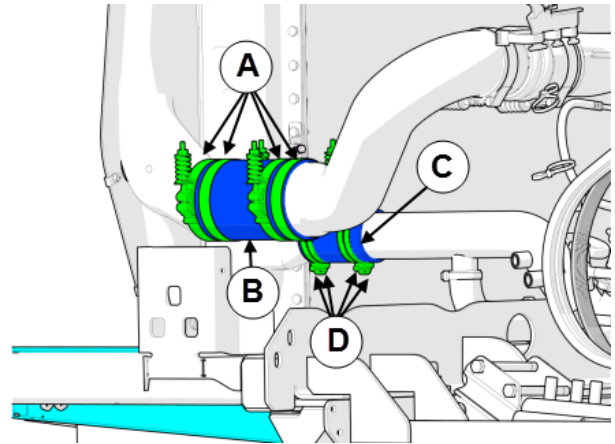

FIGURE 112

90. Reinstall all the blue flexible hoses at the CAC and radiator (at the upper connections of the cooling pack). Use the following parts::

- A: 1x flex hose #531469**
- B: 1x silicone hose #053617**
- C: 4x clamp #21490616 (torque: 5 lbf-ft)**
- D: 4x clamp #992089**

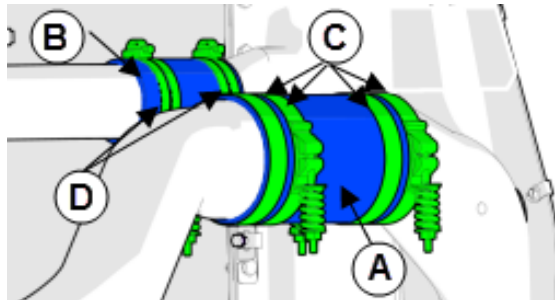

FIGURE 113

For proper clamp torque, refer to HOSE CLAMP TORQUE on page 12

91. Reinstall the lower cooling pack protector tube with the following hardware:

4x Screw #502804

4x split lock washer #5001737

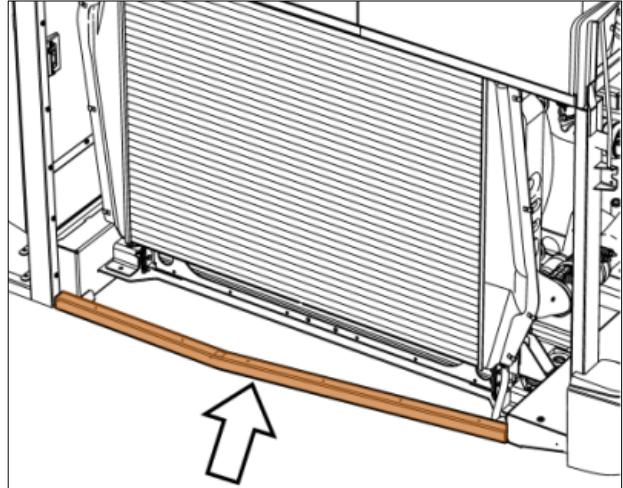

FIGURE 114

92. Install the sealing element #050200. Screw it on the existing threaded holes on the upper part of the radiator. Secure with the following hardware:

6x bolt #5001697

6x lock washer #502570

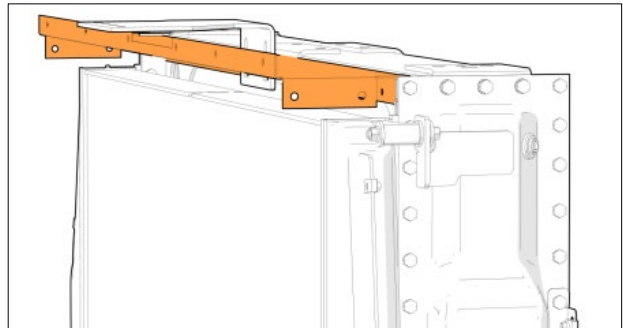

FIGURE 115

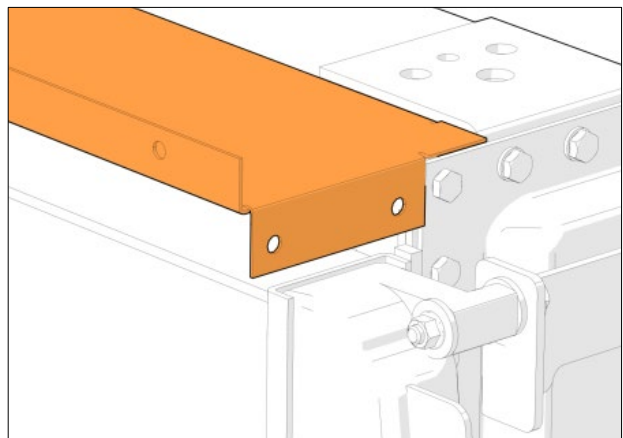

FIGURE 116

93. Install the sealing element #050203. Screw it on the existing threaded holes on the bottom of the radiator. Secure with the following hardware:

6x bolt #5001697

6x lock washer #502570

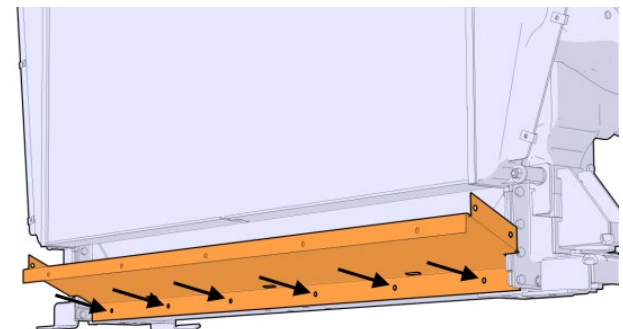

FIGURE 117

94. Prepare the sealing elements #050201 and #050202. On both parts, apply foam tape #506040 on the edges as shown on the image.

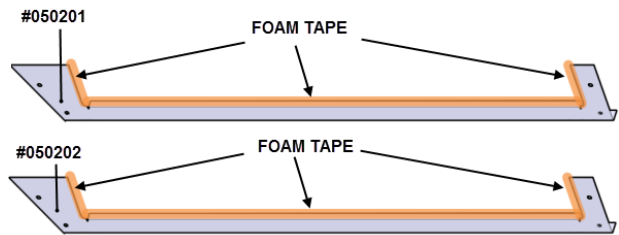

FIGURE 118

95. Install the sealing elements #050201 and #050202. Screw them onto the upper and lower sealing elements installed at the previous steps. Secure with the following hardware:

8x bolt #5001697

8x lock washer #502570

A: #050201

B: #050202

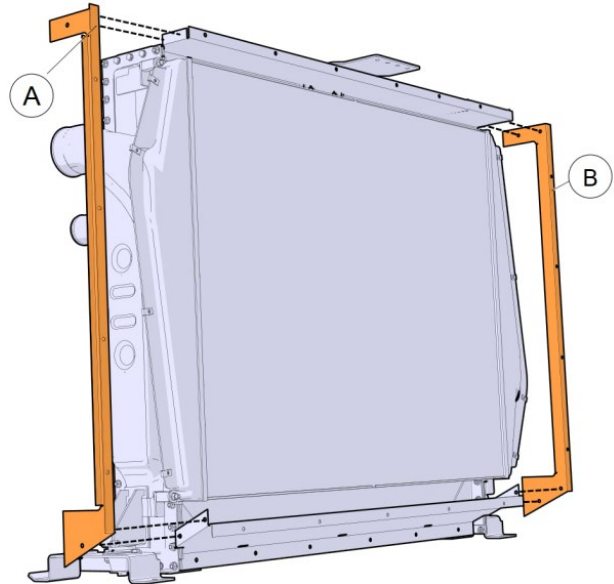

FIGURE 119

96. Cut two pieces of 39 inches (990 mm) long of **rubber extrusion #506025**.
97. Using good industrial glue (Loctite 404 or similar product), glue the two pieces of rubber extrusion centered on the reinforcement angles of fan support panel #050195.

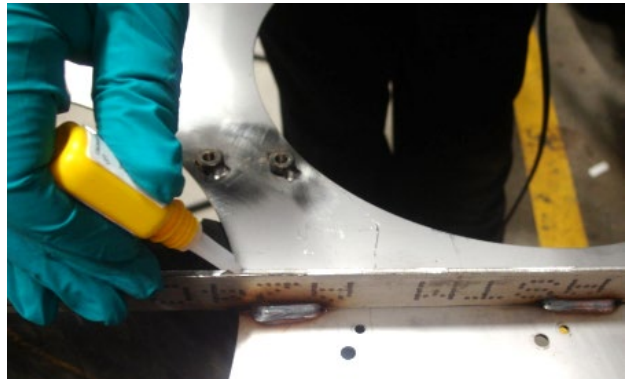

FIGURE 120

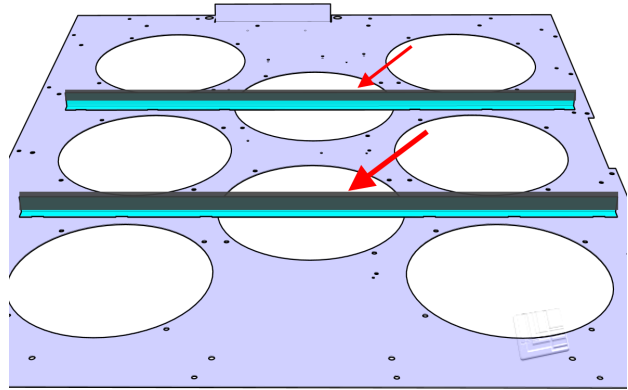

FIGURE 121

98. Install the fan support panel **#050195**. Secure with the following hardware:

19x bolt #5001697

19x lock washer #502570

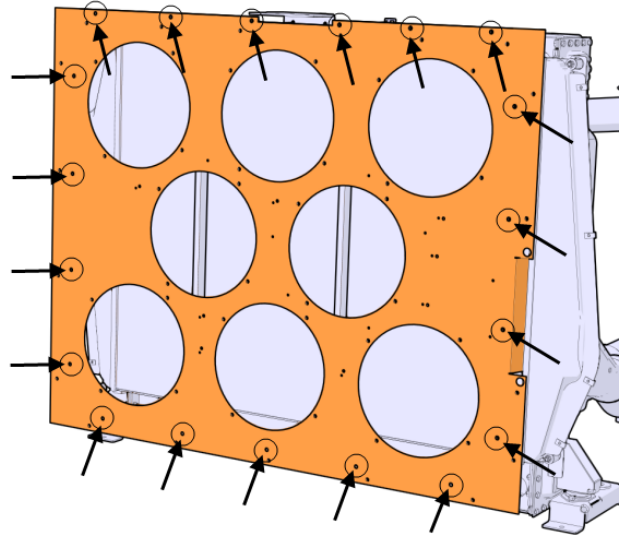

FIGURE 122

99. Install the upper left **#050204** and upper right **#050206** sealing elements.

Secure with the following hardware:

6x bolt #5001697

6x lock washer #502570

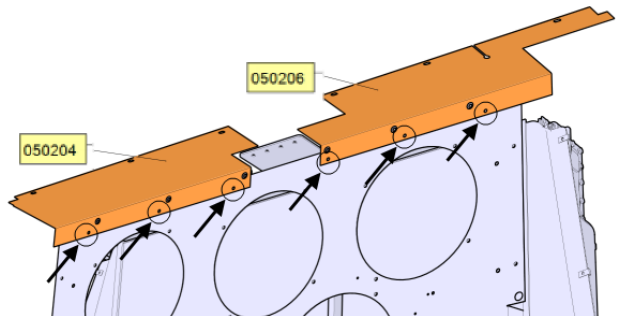

FIGURE 123

100. Install the lower sealing element **#050213**.

Secure with the following hardware:

5x bolt #5001697

5x lock washer #502570

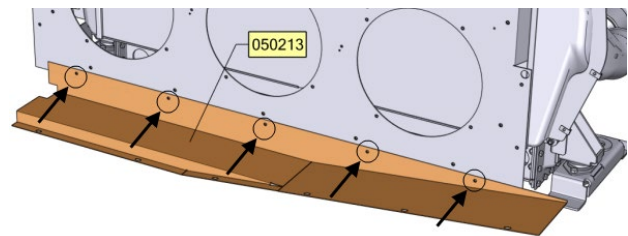

FIGURE 124

101. Install the L.H. side sealing element #050208.

Secure with the following hardware:

4 bolts #5001697

4 lock washers #502570

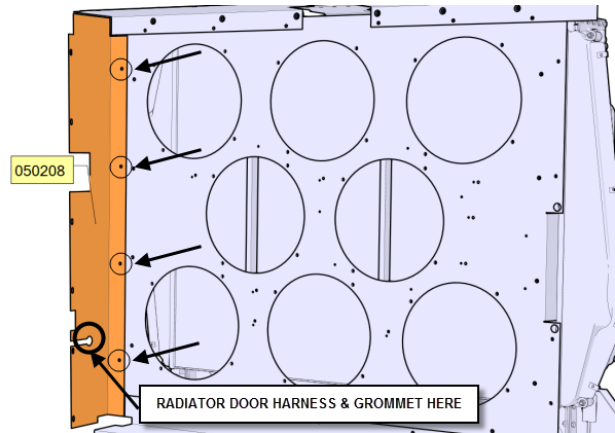

FIGURE 125

102. Install the R.H. side sealing element #050255.

Secure with the following hardware:

4x bolt #5001697

4x lock washer #502570

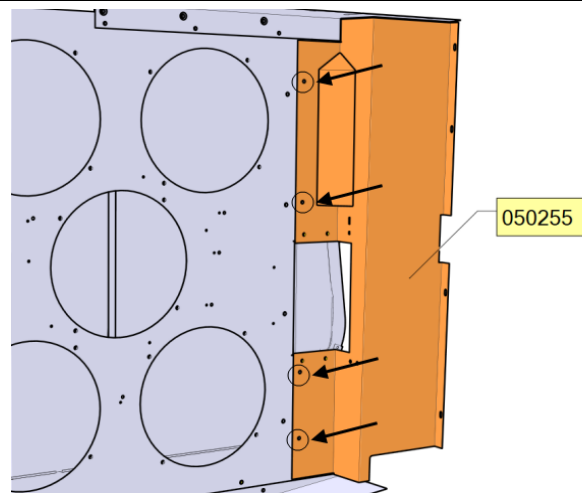

FIGURE 126

103. With a paint marker, identify the fans from 1 to 8 with the corresponding number found on a label on their respective blue connector.



104. Install the **fans** and **fan hand guards** on the panel in the same arrangement shown on the image. **Be sure to place the fan so that the cable is at the proper location, 3 O'clock, 6 O'clock or 12 O'clock.** Refer to the image at right.

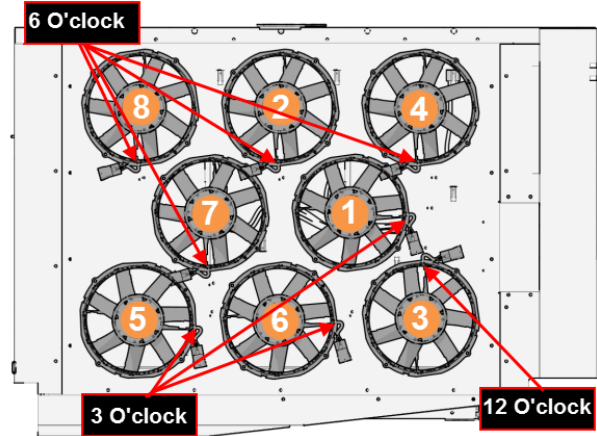

FIGURE 127

Install with the following hardware:

32x bolts #502686

32x lock washers #5001833

Prescribed torque:30 lbf-in

105. Snap the fan blue connector in the holes punches on the panel for that matter.

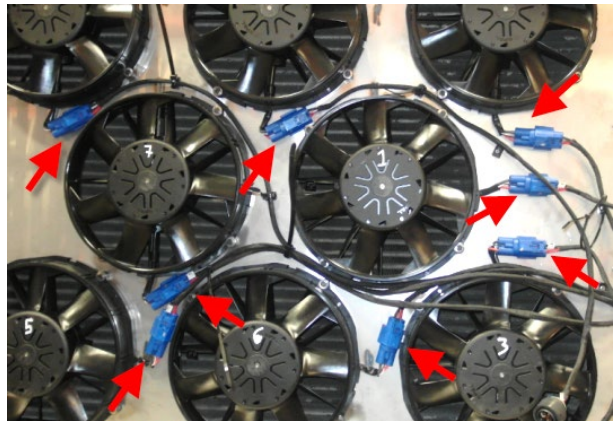

FIGURE 128

106. Route and secure the fan cables as shown on the images.

Secure with the following parts:

**A= nylon tie mount #504013 + rivet
#504379 + nylon tie #504016**

B= nylon tie #504016

Do not tighten the nylon ties at this moment



FIGURE 129

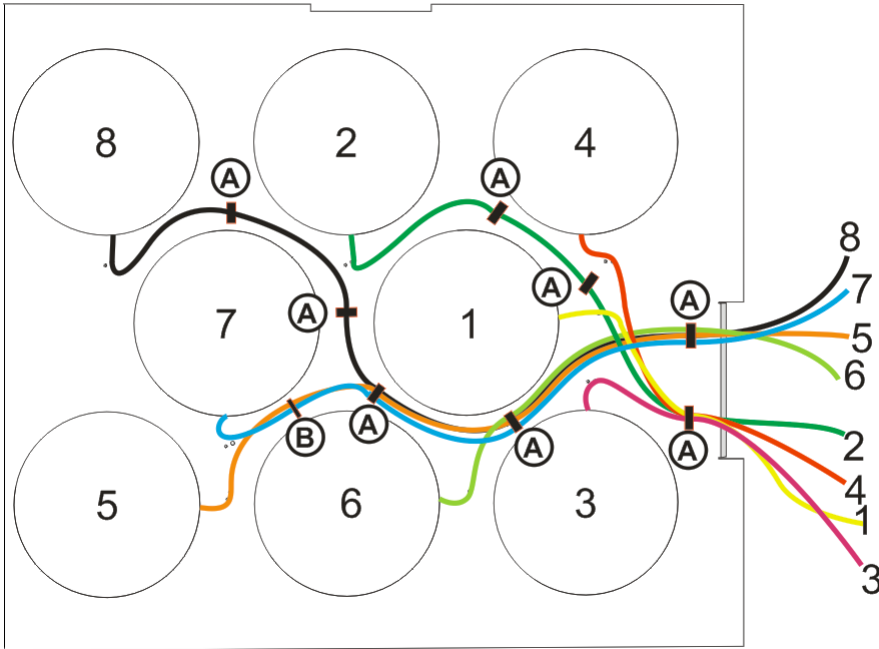

FIGURE 130

107. Install the circuit breaker box #564512.

Install with the following hardware:

4x bolt #500119

4x lock washer #5001868

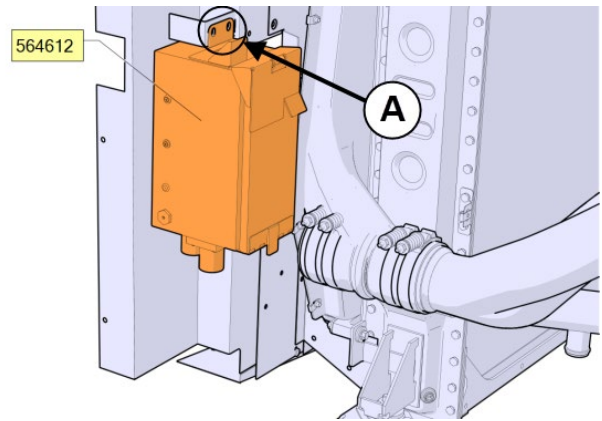

FIGURE 131

A: 2x bolt #500119 + 2x lock washer #5001868

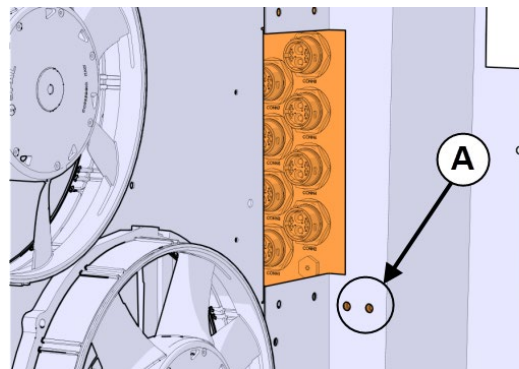

FIGURE 132

A: 2x bolt #500119 + 2x lock washer #5001868

108. Connect each fan to the corresponding connection port on the circuit breaker box.

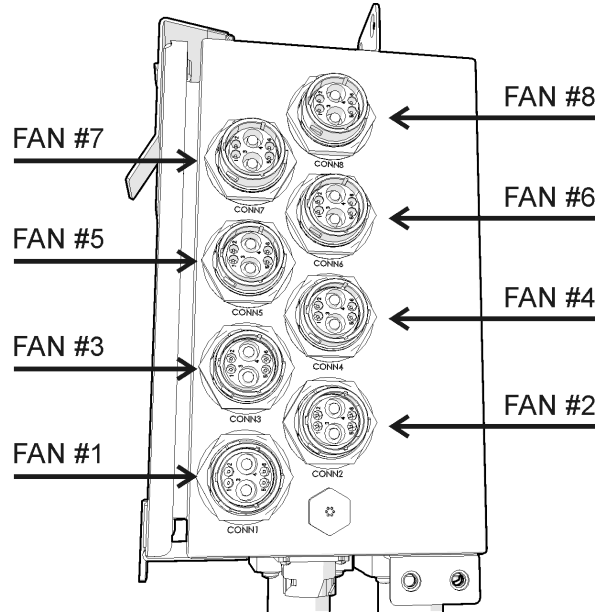

FIGURE 133

109. Tighten the nylon ties previously installed while routing the fan cables.
110. Use two (2) additional **nylon ties #504016** to secure the extra-length of cables together close to the circuit breaker box as shown on the image at right.

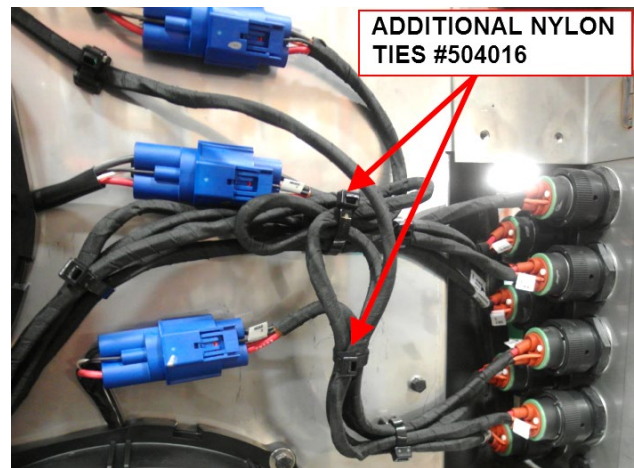

FIGURE 134

111. Install the electrical **connector cover # 050229**.

Fasten with the following hardware:

4x bolt #5001697

4x lock washer #502570

112. Using good industrial glue (Loctite 404 or similar product), glue three (3) pieces of rubber extrusion #506025 as shown on the connector cover.

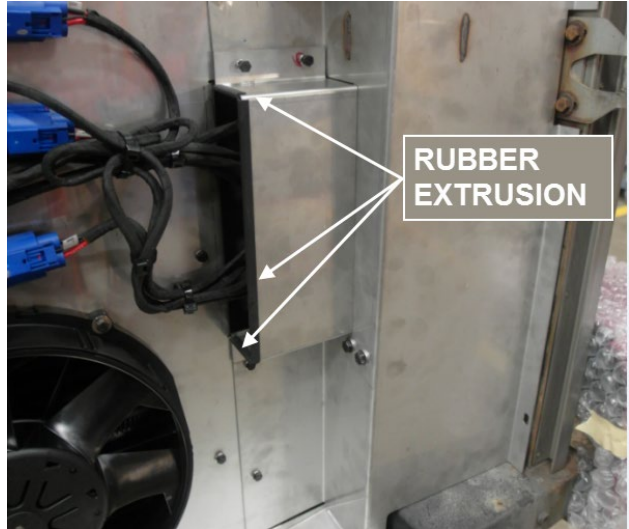

FIGURE 135



FIGURE 136

113. Complete the installation of the sealing elements. Screw the panels to the chassis threaded holes where shown on the image. Use the following hardware:

22x bolt #502848

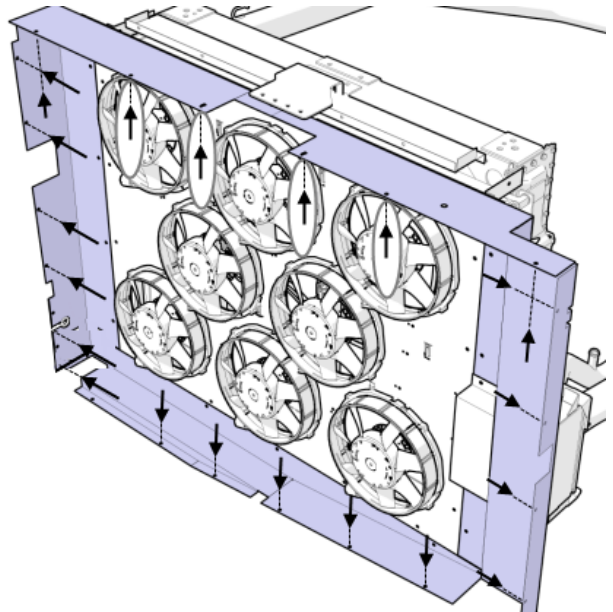

FIGURE 137

114. Complete the connection of the cables and harness to the fan circuit breakers box (three connectors: gray, black, red).

A: fan drive ground cable (black connector)

B: fan drive power cable (red connector)

C: "fan to RJB interface" harness (gray connector)

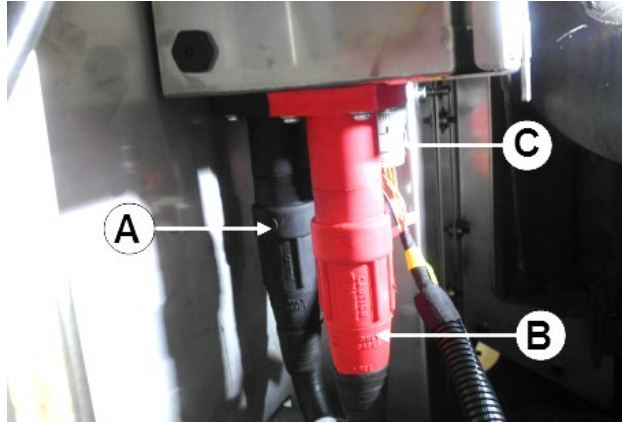

FIGURE 138

115. Secure the fan drive ground cable and the fan drive power cable connected to the fan drive circuit breakers box as shown on the pictures.

A: rivet #504379 (6x) (hole diameter: \varnothing 13/64)

B: tie mount #504013 (6x)

C: nylon tie #504016 (6x)

D: handcuff nylon tie #N37749 (1x)

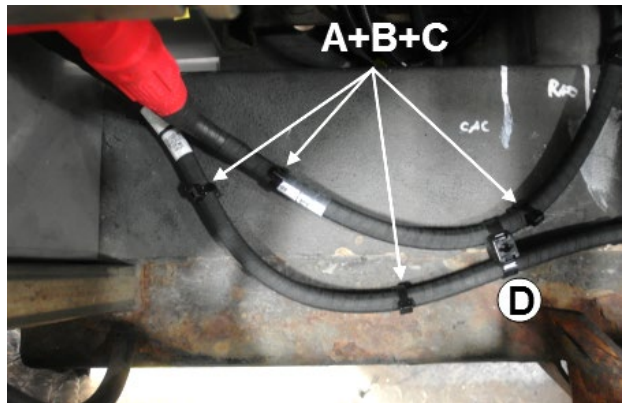

FIGURE 139

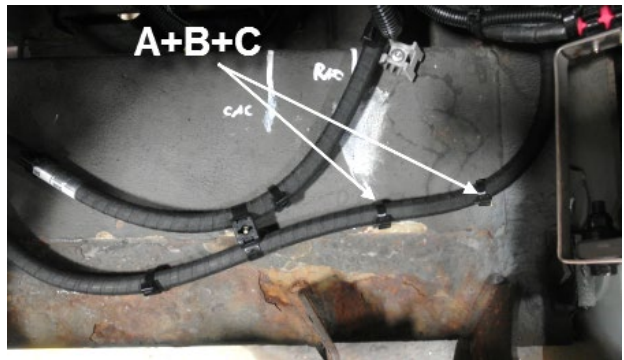

FIGURE 140

116. Connect the alternator control harness connector **C-ALT3** to connector **C-ALT3** of the "fan to RJB interface" harness. Secure the extra length of harness as shown with nylon ties.

A: handcuff nylon tie #N37749 (3x)

B: nylon tie #504016 (4x)

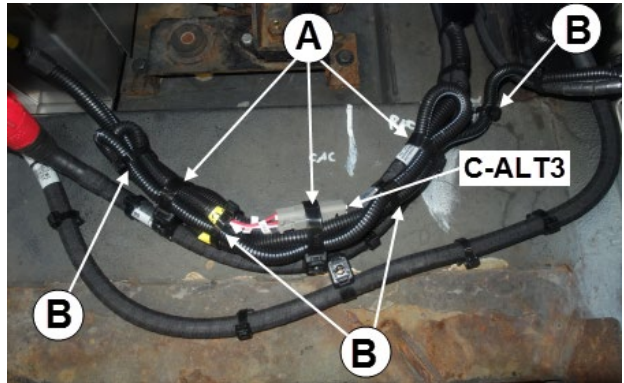

FIGURE 141



FIGURE 142

INSTALLATION OF ELECTRIC COMPONENTS AND HARNESS CONNECTIONS IN THE MAIN POWER COMPARTMENT

SCHEMATIC DIAGRAM OF ELECTRICAL CABLES & HARNESSES

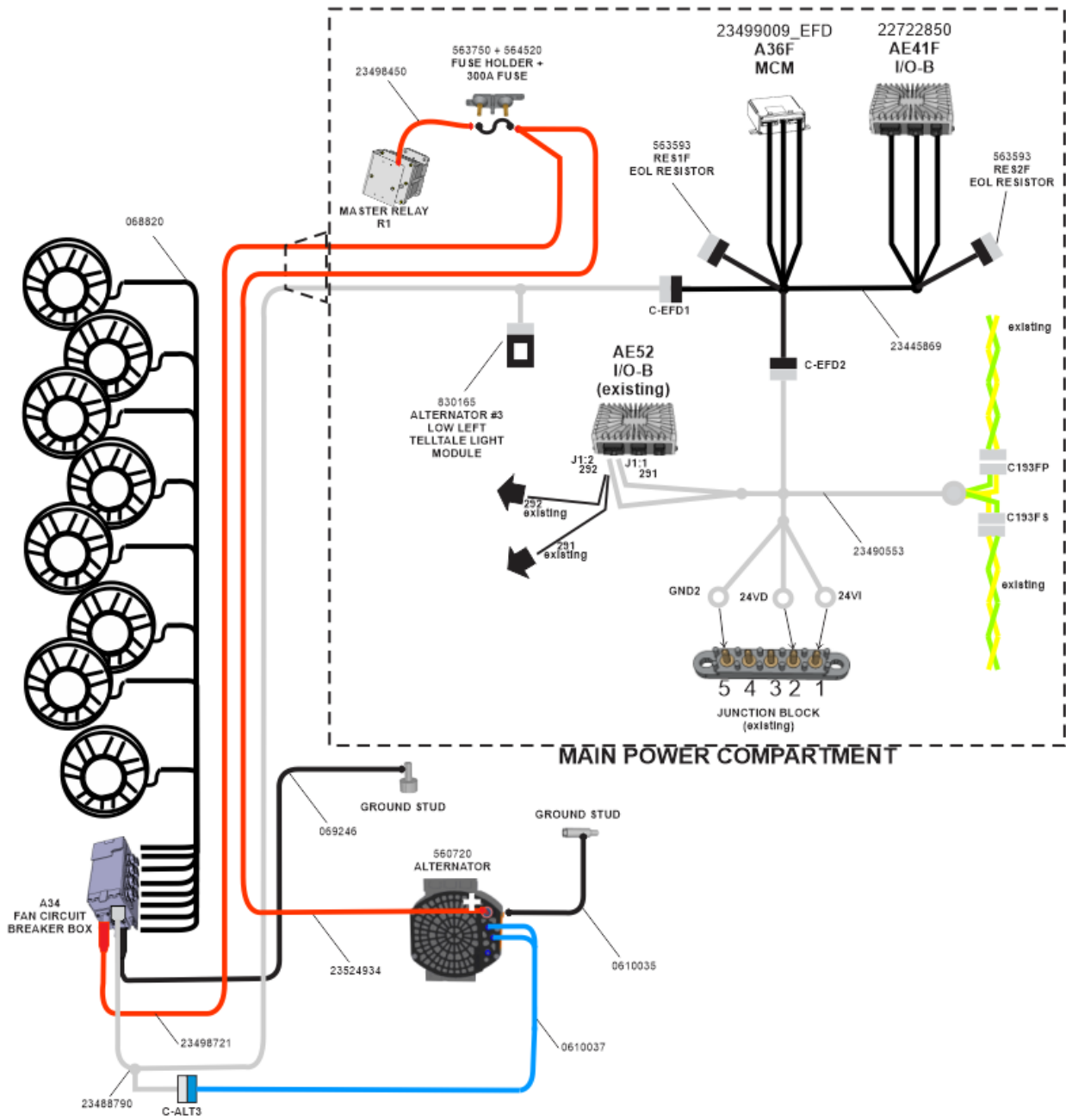

117. In the battery compartment, disconnect the battery ground cable from the chassis ground stud.

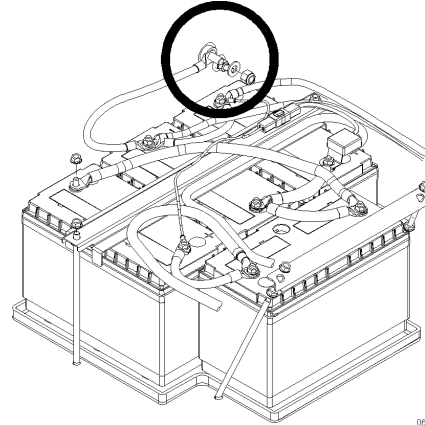

118. Most of the electric components will be installed on the bulkhead at the right of **master relay R1** (when facing it). Identify the master relay R1 on the image at right.

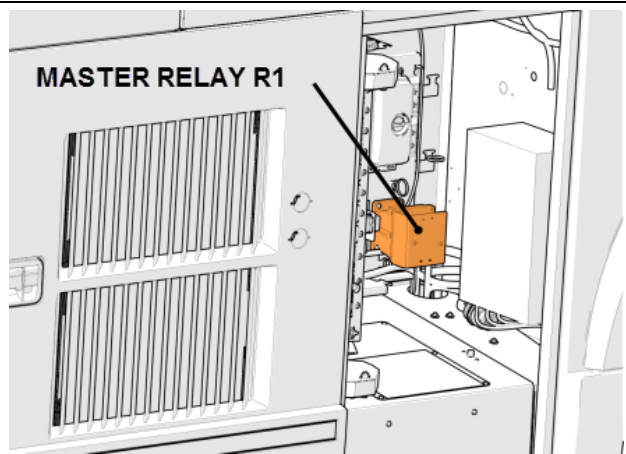

FIGURE 143

119. If the situation applies to the vehicle on which you are working on, remove the two (2) useless studs found on the bulkhead and then sand to leave a smooth surface.

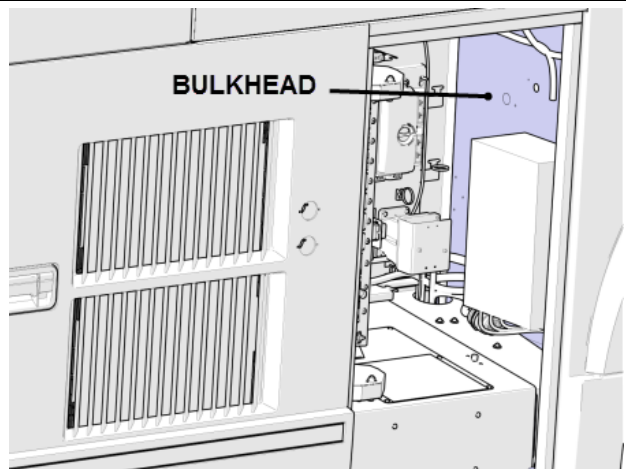

FIGURE 144



FIGURE 145

120. Make sure this is no voltage at the master relay R1 posts and then, remove the master relay R1 cover.

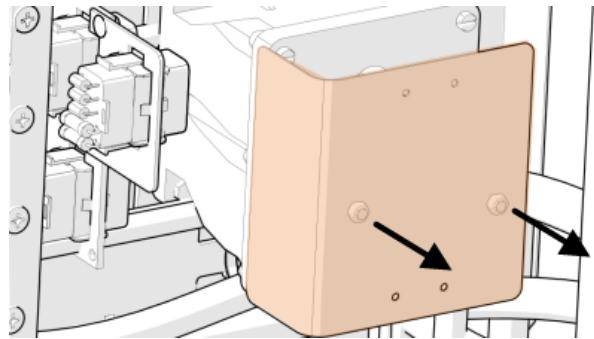

FIGURE 146

121. Disconnect the four (4) cable lugs connected to the master relay R1 upper post.
122. Momentarily, connect the elbowed lug of the “master relay R1 to 300A fuse” cable #23498450.

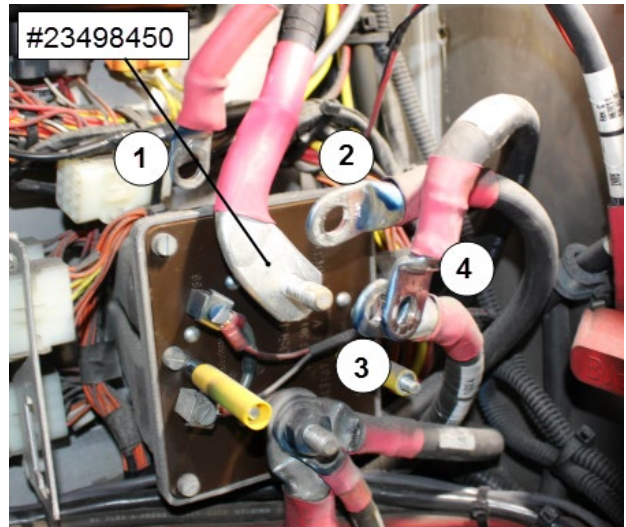

FIGURE 147

123. Find the best location where to install the fuse holder #563750 on the bulkhead. Take note that the fuse holder must be installed at the distance that allows cable #23498450 to reach it.

124. Drill two 11/64 pilot holes for the installation of the fuse holder on the main power compartment bulkhead. Secure with the following hardware:

A: tapping screws #500658 (2x) + flat washer #5001341 (2x)

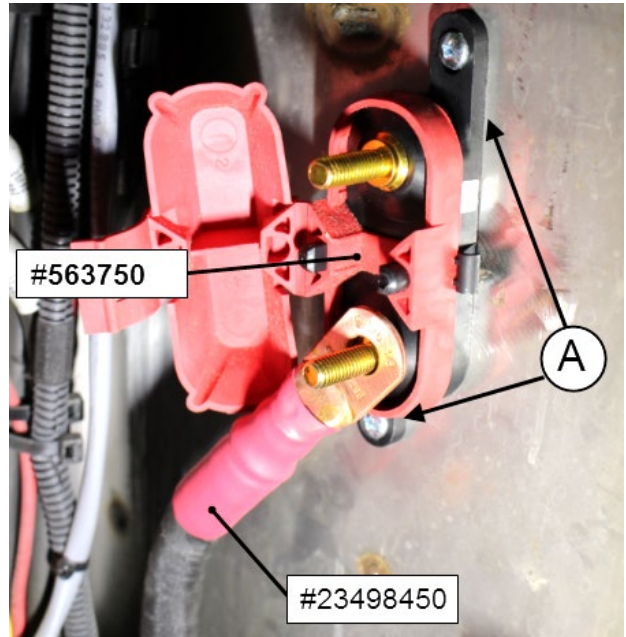

FIGURE 148

125. Reinstall the four (4) other cable lugs to the master relay R1 upper post.

Being the largest lug at R1, the cable #23498450 lug should be placed first on the post (behind all the other lugs) (or second if rubbing is likely to happen).

Master relay R1- Port 30 – M10-1.5 stud nut torque: 160-195 lb-in (18-22 Nm)

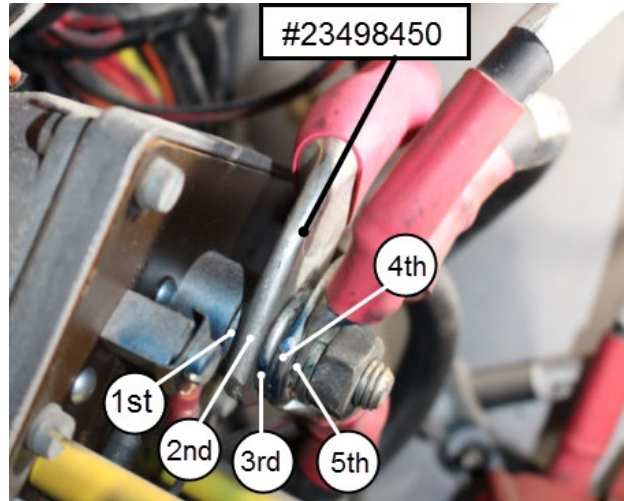

FIGURE 149: ON THIS PICTURE, CABLE #23498450 LUG IS IN SECOND (2ND) POSITION BECAUSE IT WAS LIKELY TO RUB ON THE HEAD OF ONE OF THE FOUR SCREWS.

126. Reinstall the master relay R1 cover.

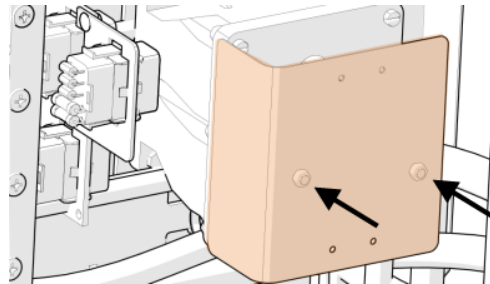

FIGURE 150

127. Place the **300A fuse #564520** in the fuse holder underneath the cable lugs.

128. Connect to the free post of the fuse holder the two (2) following cables that are routed from the alternator and the fan drive circuit breakers box:

- **Fan drive power cable #23498721**
- **L.H. alternator power cable #23524934**

A: nut #5001983 (2x)

B: washer #5001341 (2x)

Thread the nuts and tighten to a torque of 96 lbf-in (11Nm).

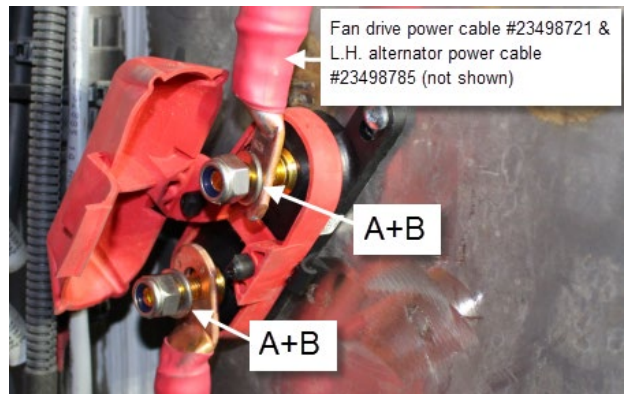

FIGURE 151: TAKE NOTE THAT THE 300A FUSE IS NOT PRESENT ON THE PICTURE ABOVE BUT IT SHOULD BE INSTALLED AT THIS STEP

129. Secure the “fan drive power” cable and the “L.H. alternator power” cable as shown on the pictures at right using the following parts:

A: tie mount #509490 (2x)

B: rivet #504610 (2x) (hole diameter: \varnothing 17/64)

C: nylon tie #509491 (3x)

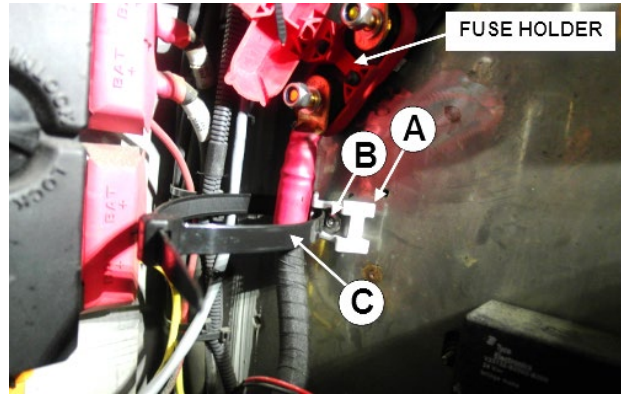

FIGURE 152

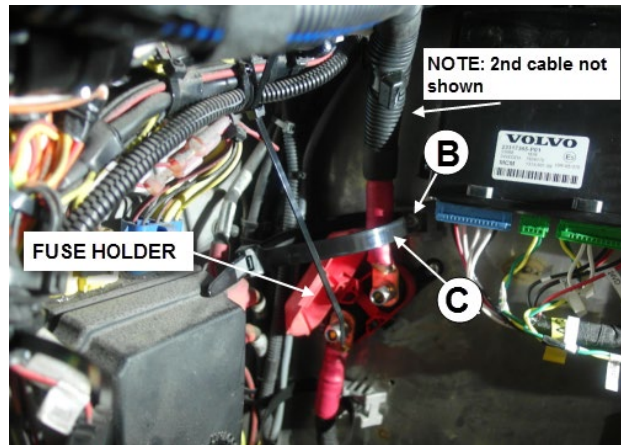

FIGURE 153

130. Install the MCM #23499009-EFD and the I/O-B module #22722850 on the bulkhead.

- Spacing between the I/O-B and the MCM=1 inch
- Pilot holes diameter: 11/64”

Install with the following hardware:

Tapping screws #500658,

3x for the MCM

4x for the I/O-B module

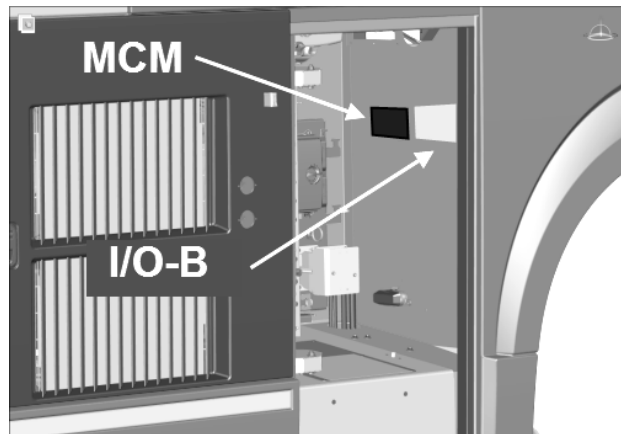

FIGURE 154: MAIN POWER COMPARTMENT

131. Depending on the coach configuration, an existing mounting plate may extend where the MCM should be installed and cause interference. If this mounting plate useless, cut it off along the red line shown on the image.

IMPORTANT: Do not leave a sharp edge. Smooth down the edge.



FIGURE 155

132. In the main power compartment, connect the “fan to RJB interface harness” to the “MCM to I/O-B interface harness” #23445869 by means of connector C-EFD1.
133. Connect the MCM and the I/O-B module together using the “MCM to I/O-B interface harness” #23445869.
134. Connect the OEL resistors connector **RES1F** and **RES2F** (part #563593) to the “MCM to I/O-B interface harness”. See the image at right and the following pictures for reference.

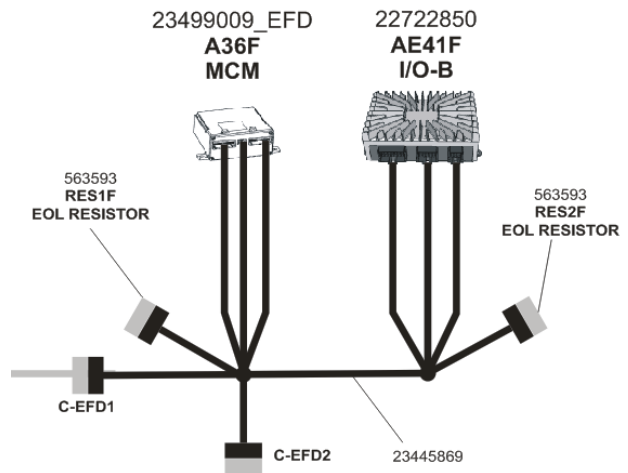

FIGURE 156



FIGURE 157

A:nylon tie #504016 (3x)

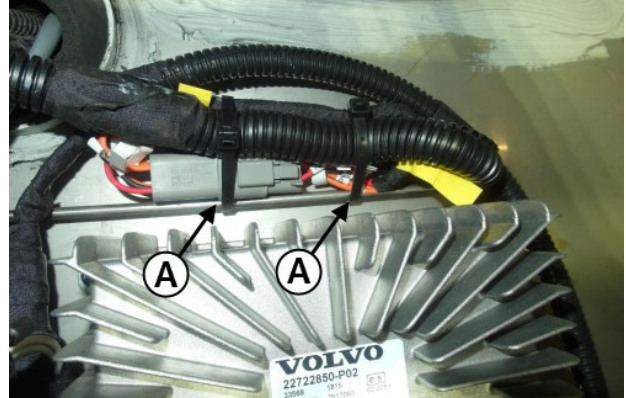

FIGURE 158

A:nylon tie #504016 (2x)

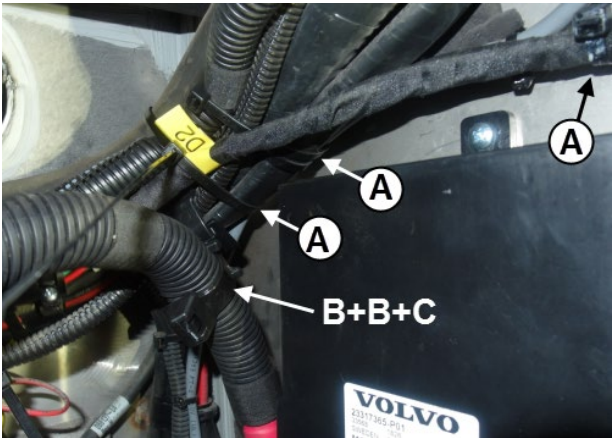

FIGURE 159

A:nylon tie #504016 (3x)

B:nylon tie #509491 (2x)

C:swivel mount #504751 (1x)

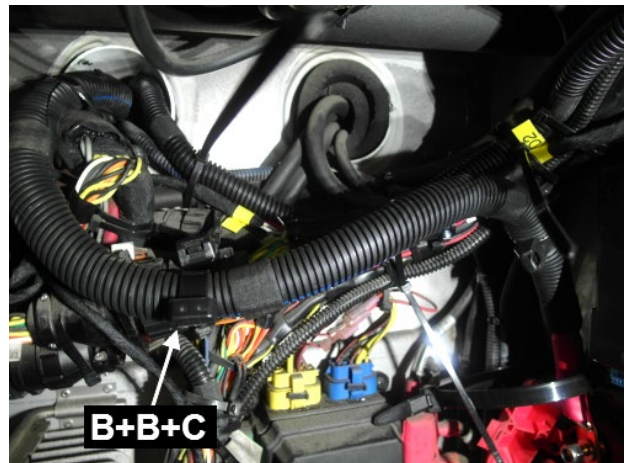

FIGURE 160

B:nylon tie #509491 (2x)

C:swivel mount #504751 (1x)

135. In the main power compartment, connect the “**vehicle interface harness**” #23490553 to the “MCM to I/O-B interface harness” by means of connector C-EFD2.

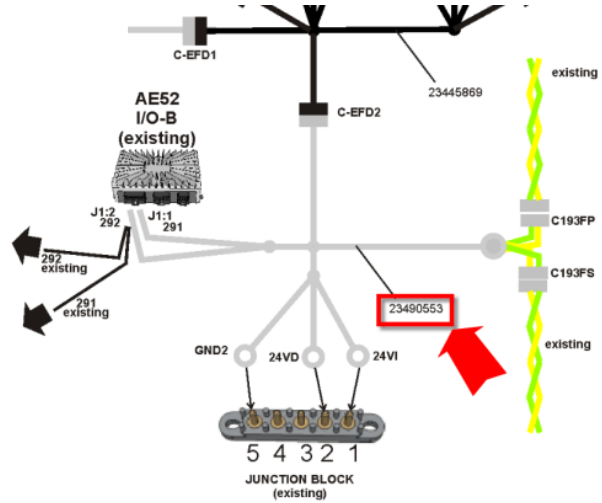

FIGURE 161

136. Connect circuit 24VI, 24VD & GND2 to post 1, 2 & 5 respectively of the junction block.

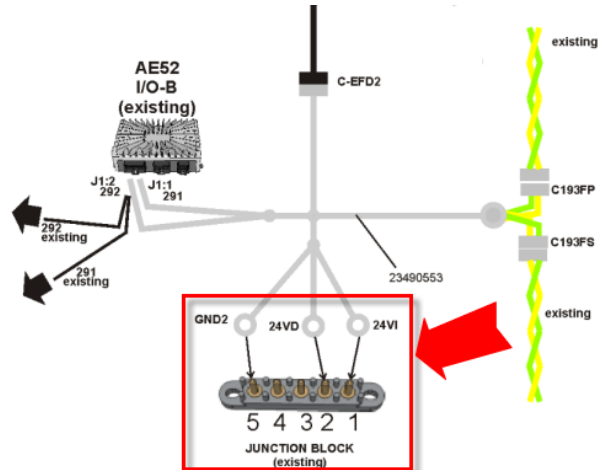

FIGURE 162

137. Get the J1939 signal. To do so, locate connector C193 among the existing harnesses in the main power compartment.
138. Disconnect connector C193 and connect with C193FS and C193FP of the “**vehicle interface harness**” #23490553.

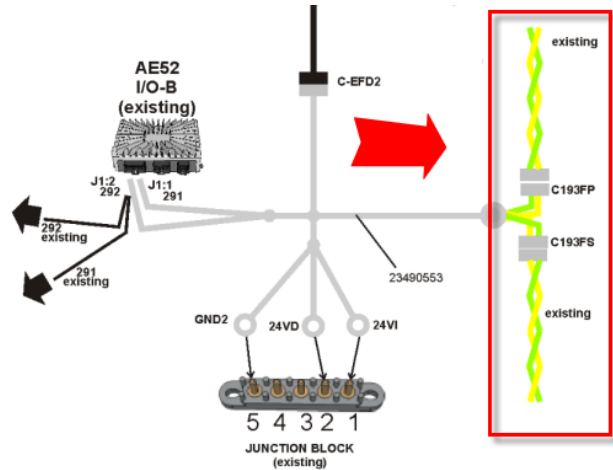

FIGURE 163

139. In the main power compartment, locate I/O-B module A52 (alternately named AE52).
140. At **A52** (or AE52), remove existing circuit 291 and 292 from connector J1:1 (pin 1) and J1:2 (pin 2).
141. For each circuit, cut the terminal and put a heat shrinking sleeve at the end of the wire. Those circuits won't be used anymore.
142. Insert circuit 291 and 292 of the **"vehicle interface harness" #23490553** into connector J1 pin 1 and J1 pin 2 respectively.

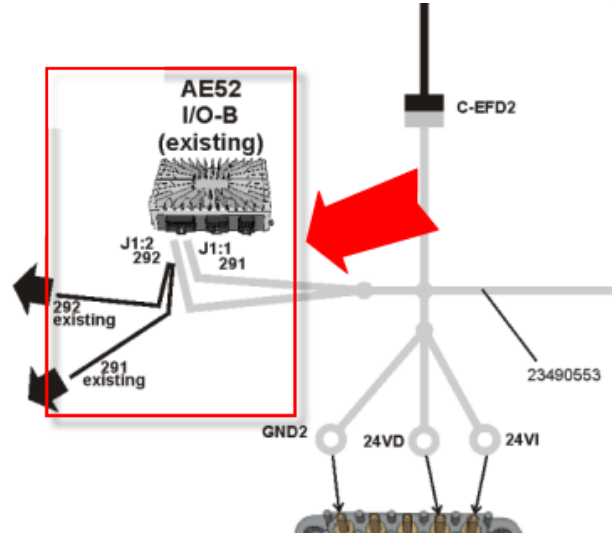

FIGURE 164

143. Install the U-shaped telltale light module bracket #381594 at an appropriate place in the electrical compartment where it can be reached by the **"fan to RJB interface"** harness.
Fasten to the bulkhead using two (2) rivets #504379 (hole diameter: \varnothing 13/64).
144. Install two tab terminals #561540 on the 24V red telltale light module (#830165) wires.
145. Install the telltale light module in the telltale module bracket #381594. Using a P-Touch, make a label indicating "LH ALT".
146. Connect the appropriate branch of the **"fan to RJB interface harness"** to the telltale light module.

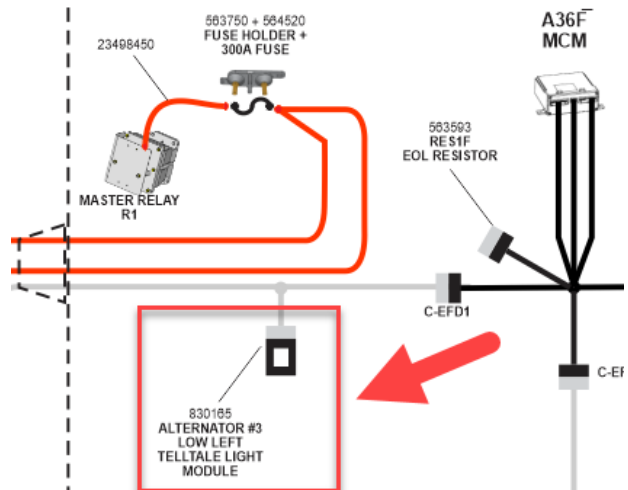

FIGURE 165

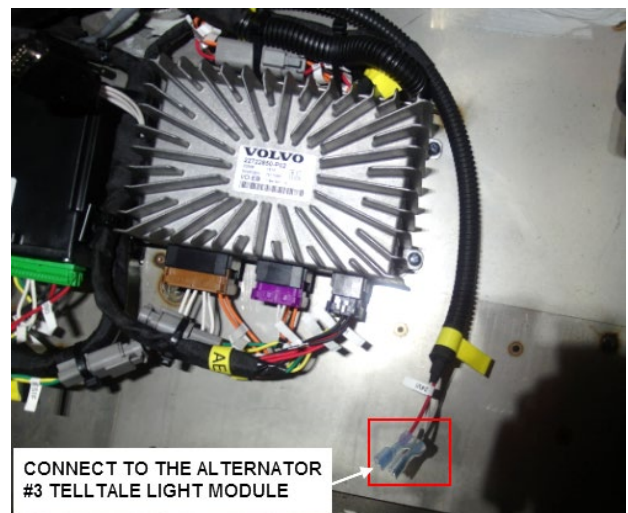

FIGURE 166

147. There are remaining nylon ties and tie mounts in the kit. Use them to secure the harnesses and cables that may seem loose. The goal is to prevent rubbing of the cables and harnesses.

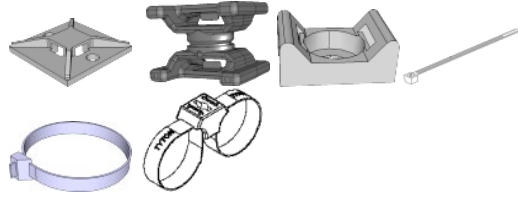

FIGURE 167

148. Install one (1) warning decal #069205 as shown on the image.

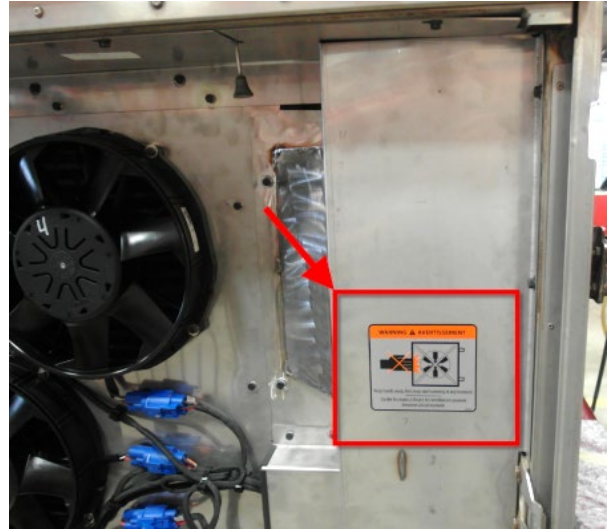

FIGURE 168

149. Install a second warning decal #069205 as shown on the radiator door.

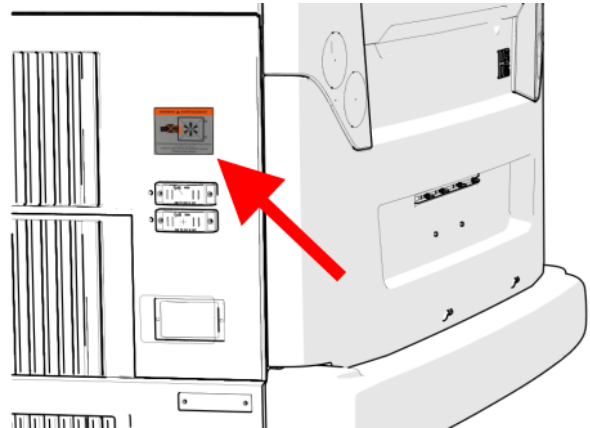

FIGURE 169

150. Fasten the radiator door **upper arm assembly**.

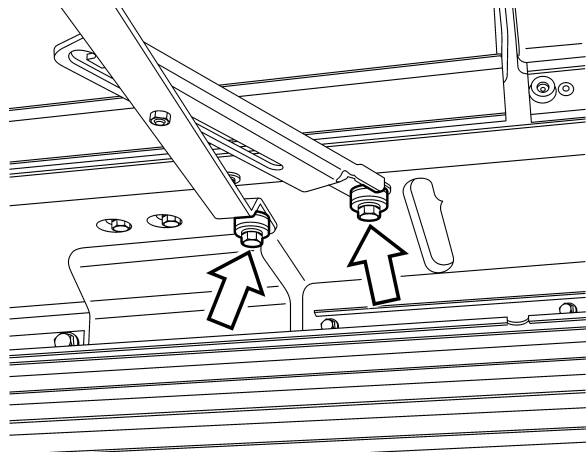

FIGURE 170

151. Refill the cooling system. Connect coolant extractor. Use coolant extractor to refill the coolant from the engine.

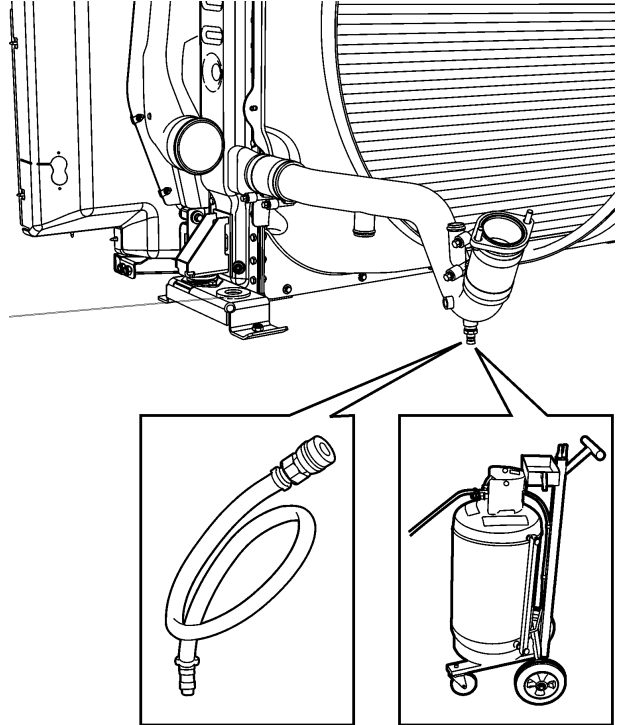

FIGURE 171

152. Reinstall the rear bumper.

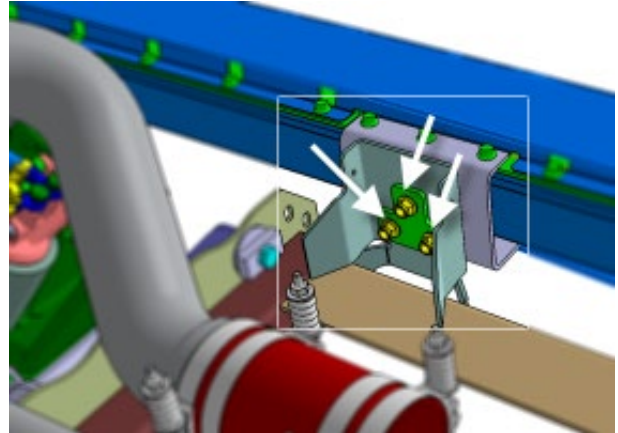

FIGURE 172

153. Reinstall the **access panel** located behind tag axle L.H. side wheel.

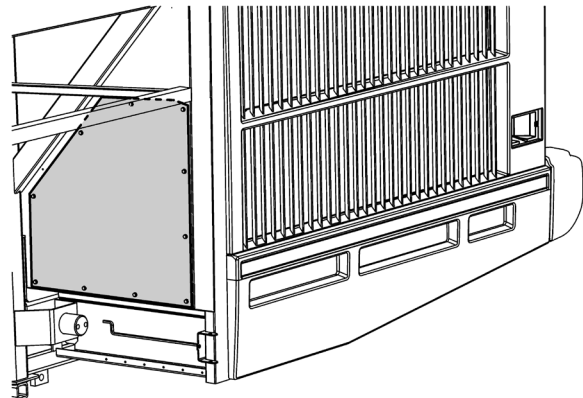

FIGURE 173

154. Reinstall L.H. side rear fender.

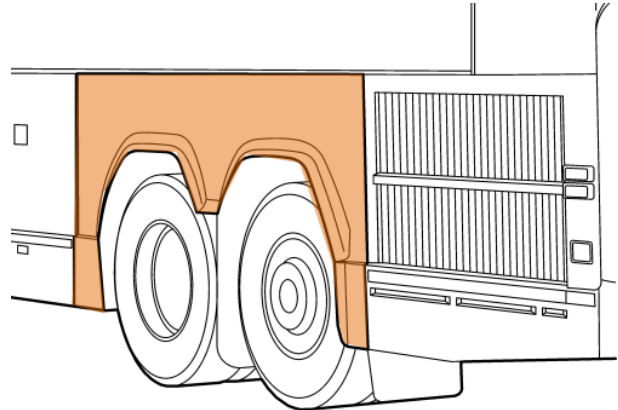

FIGURE 174

155. In the battery compartment, connect the battery ground cable to the chassis ground stud.

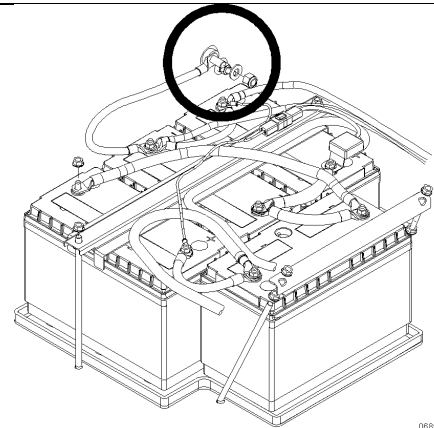

FIGURE 175

156. In the main power compartment, set the battery master switch to the ON position.

157. Set the ignition switch to the ON position.

158. In the main power compartment, reset the circuit breakers and wait two (2) minutes for the new installer I/O-B module to be programed.

IMPORTANT NOTE

VEHICLES EQUIPPED WITH OPTIONAL PRIME ENERGY MANAGEMENT SYSTEM

TO PREVENT OVERLOADING THE L.H. SIDE ALTERNATOR, IT IS VERY IMPORTANT TO DISABLE « PRIME » SYSTEM ON VEHICLES RECEIVING THIS CONVERSION. PLEASE CONTACT YOUR NEAREST PREVOST SERVICE CENTER TO HAVE THE PRIME SYSTEM DISABLED. A SOFTWARE TOOL IS NEEDED TO DO SO.

SYSTEM TEST

159. Start the engine to idle.
160. With the engine in idle (600 rpm), use the Diagnostics menu of the Driver Information Display to engage the fans in speed 1.

Diagnostics > Vehicle Tests > Activate Radiator FAN Speed 1

The height (8) fans should run at 50% of the maximum speed. You need to evaluate the sound level and the power of the air stream to determine the speed.

161. Engage the fans in speed 2.

Diagnostics > Vehicle Tests > Activate Radiator FAN Speed 2

The eight (8) fans should run at 75% of the maximum speed.

162. Set the engine to the fast idle, the fans should then engage at 100% of the maximum speed.
163. If the fans behave in accordance with the criterions of the previous steps, then they operate normally.

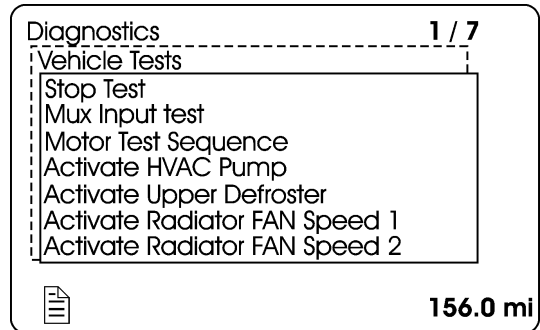

PARTS / WASTE DISPOSAL

Discard waste according to applicable environmental regulations (Municipal/State[Prov.]/Federal)

APPENDIX A

The following pages are available on the Prevest Technical Publications site under *Wiring Diagrams* tab.

X3-Electric Fan Drive conversion kit		Seated Coach X, Converted Coach Shell X	X3-45 X3-45 VIP X3-45 VIP Commercial Use X3-45 Commuter	2011 - 2019	Go to Diagram
H3-Electric Fan Drive conversion kit	B-1721 - K-0185	Seated Coach H, Converted Coach Shell H	H3-41 H3-41 VIP H3-45 H3-45 VIP	2011 - 2019	Go to Diagram

X3 Series:

<https://techpub.prevestcar.com/en/download?id=9074&type=wiring-diagrams-search-pages>

H3 Series:

<https://techpub.prevestcar.com/en/download?id=9073&type=wiring-diagrams-search-pages>



Wiring Schematic Aftermarket Electric Fan Drive kit

EFD H345 US10 to GHG17

EFD with Bosch Alternator KIT # IS19900

EFD with Remy Alternator KIT #IS19910

Apply to all H3 model from B-1721 up to K-0185

Dec 2018

Engine compartment component

Fan and shroud installation



Fan power BOX



3rd alternator

Rear junction box components

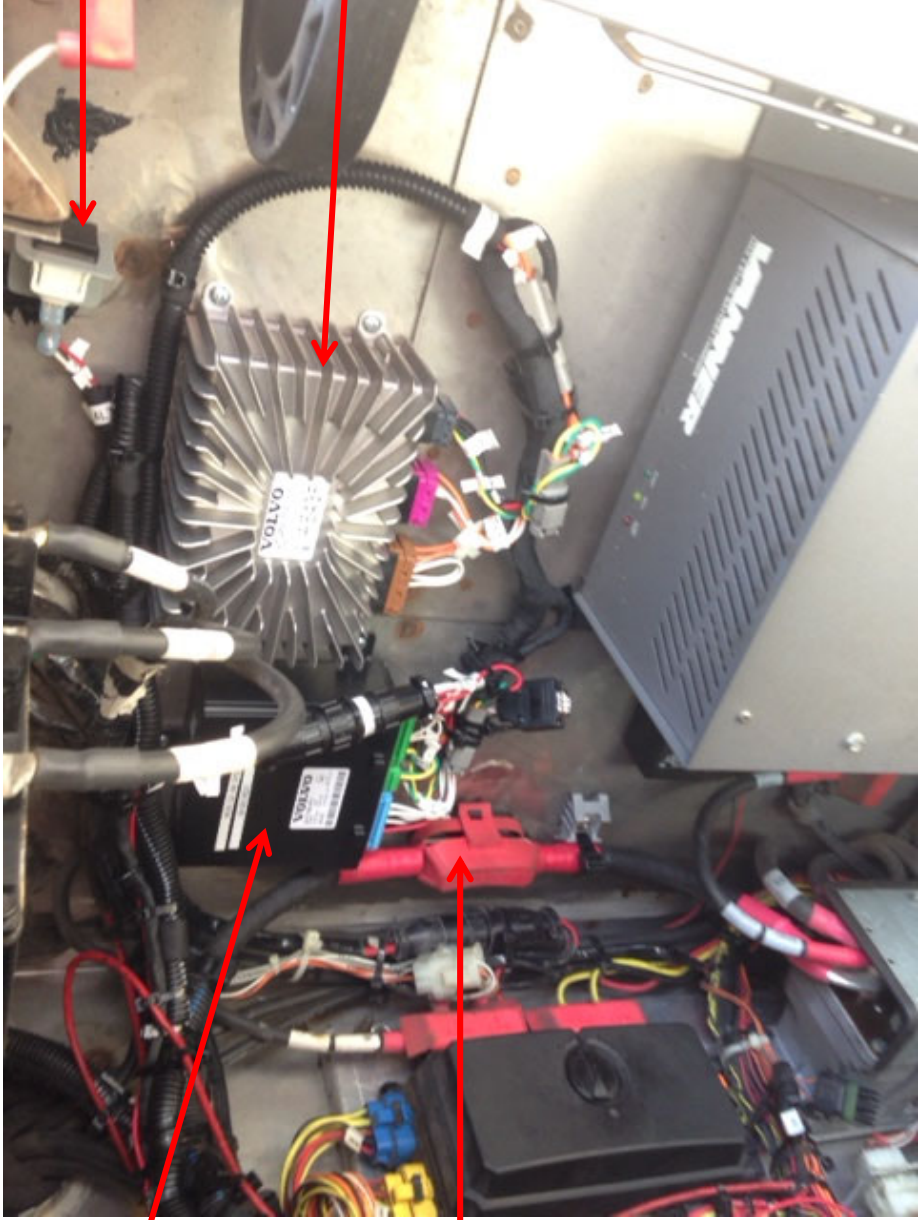

3rd alternator
light indicator

I-OEB module
AE41F

MCM 2.0
A36F

300A
fuse

WIRING HARNESS AND BATTERY CABLE

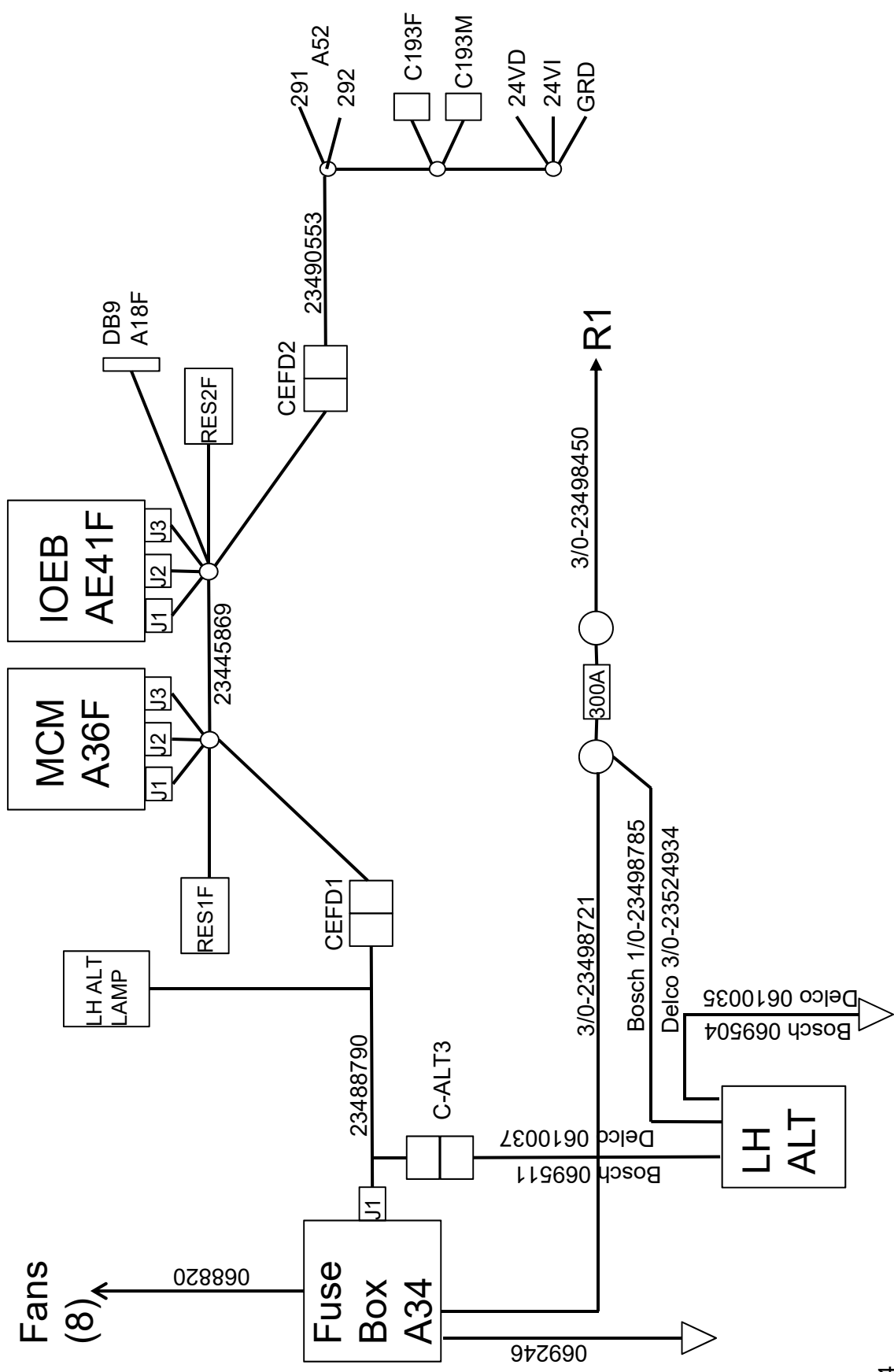

WIRING DIAGRAM MCM

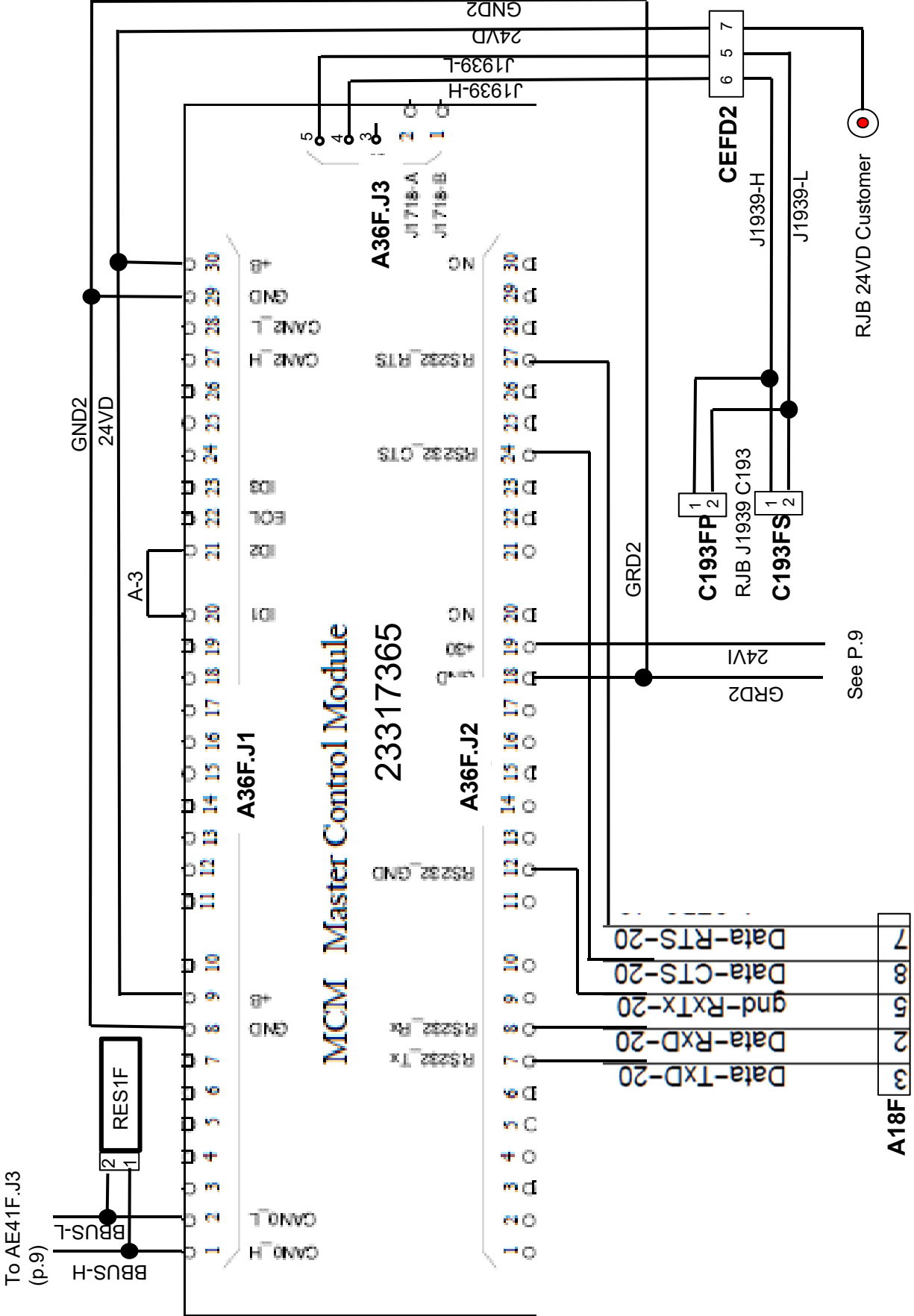

WIRING DIAGRAM I-O module

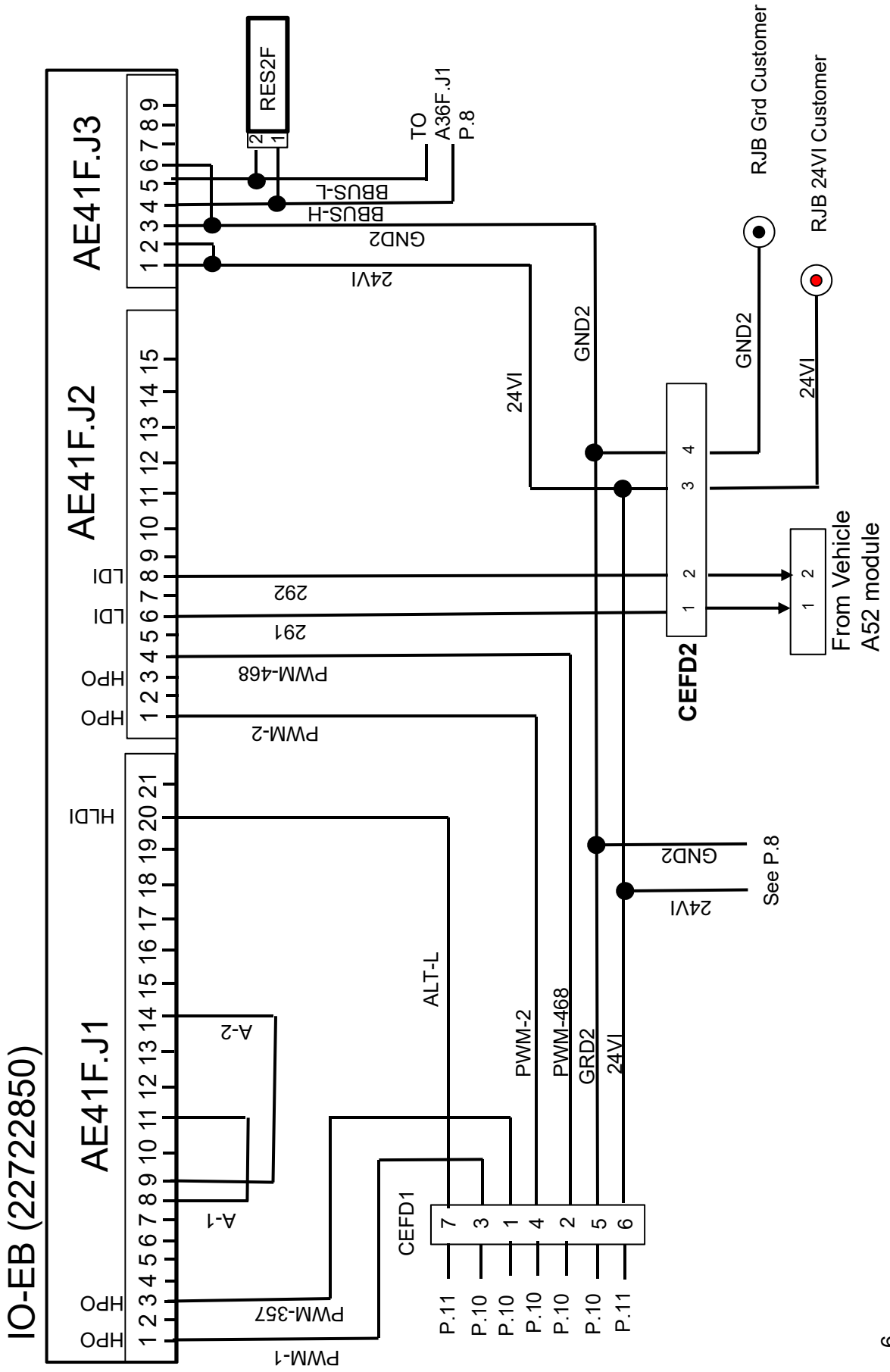

WIRING DIAGRAM FAN

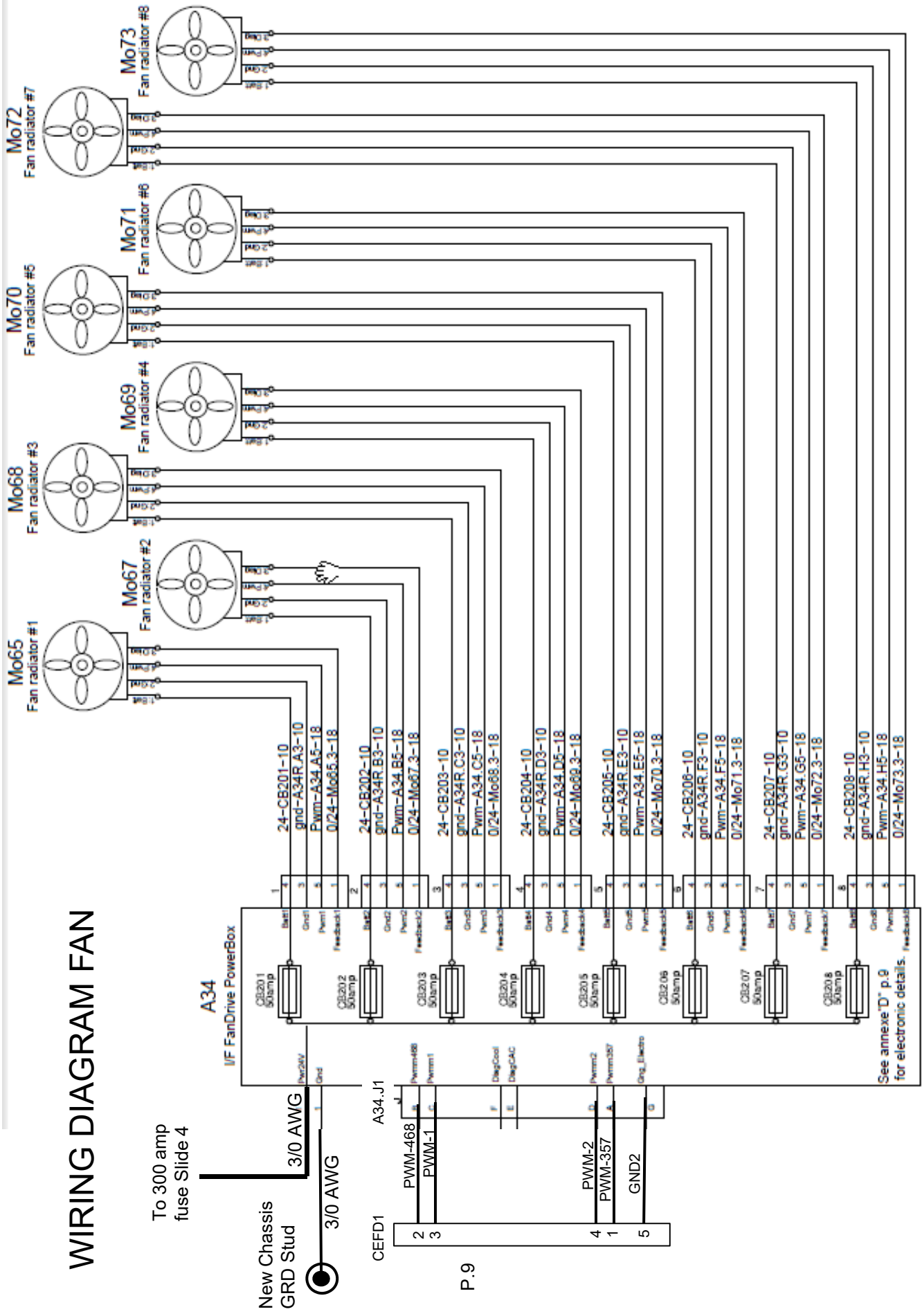

PREVOST.

3RD BOSCH ALT WIRING DIAGRAM

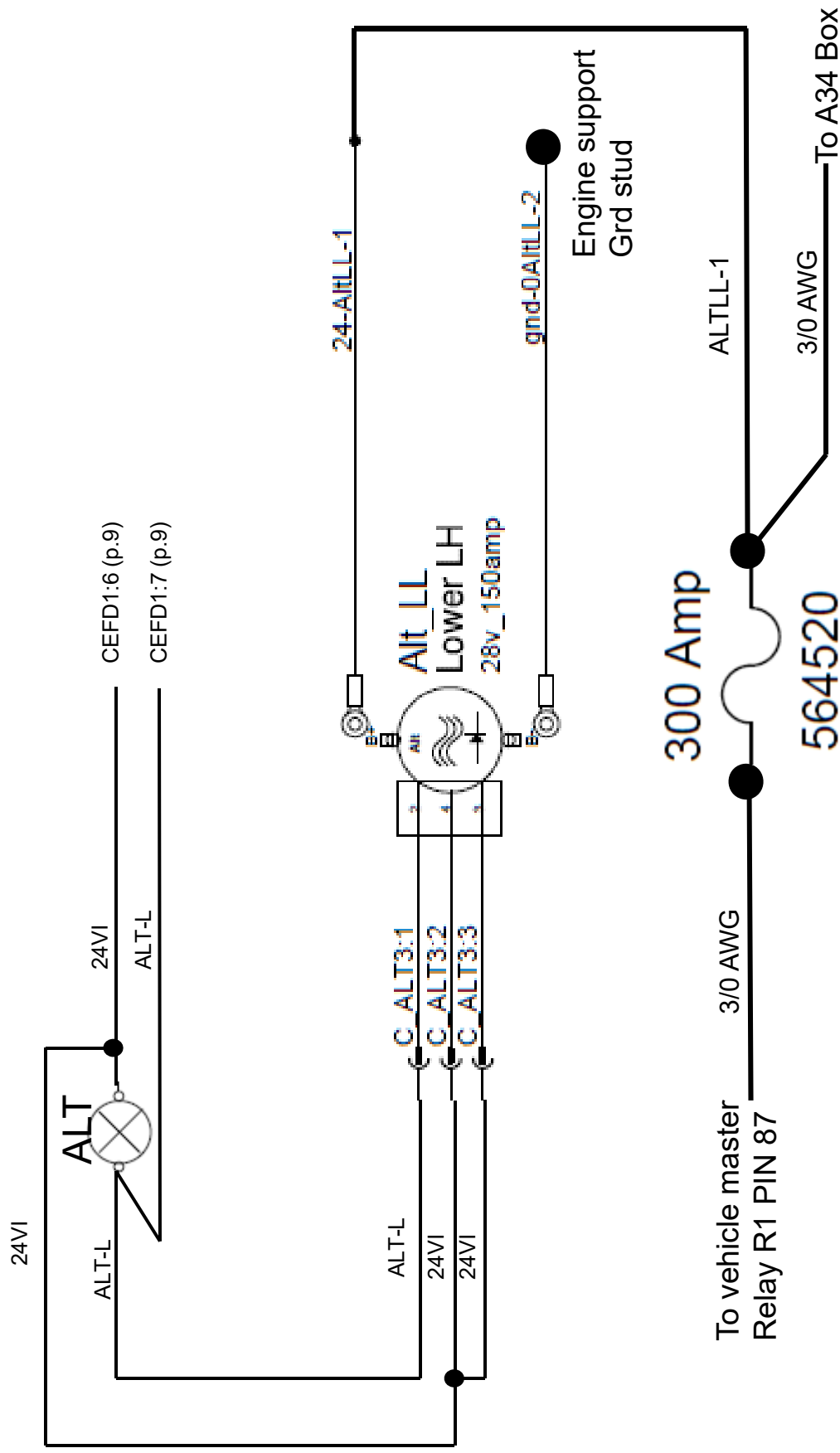

2ND REMY ALT WIRING DIAGRAM

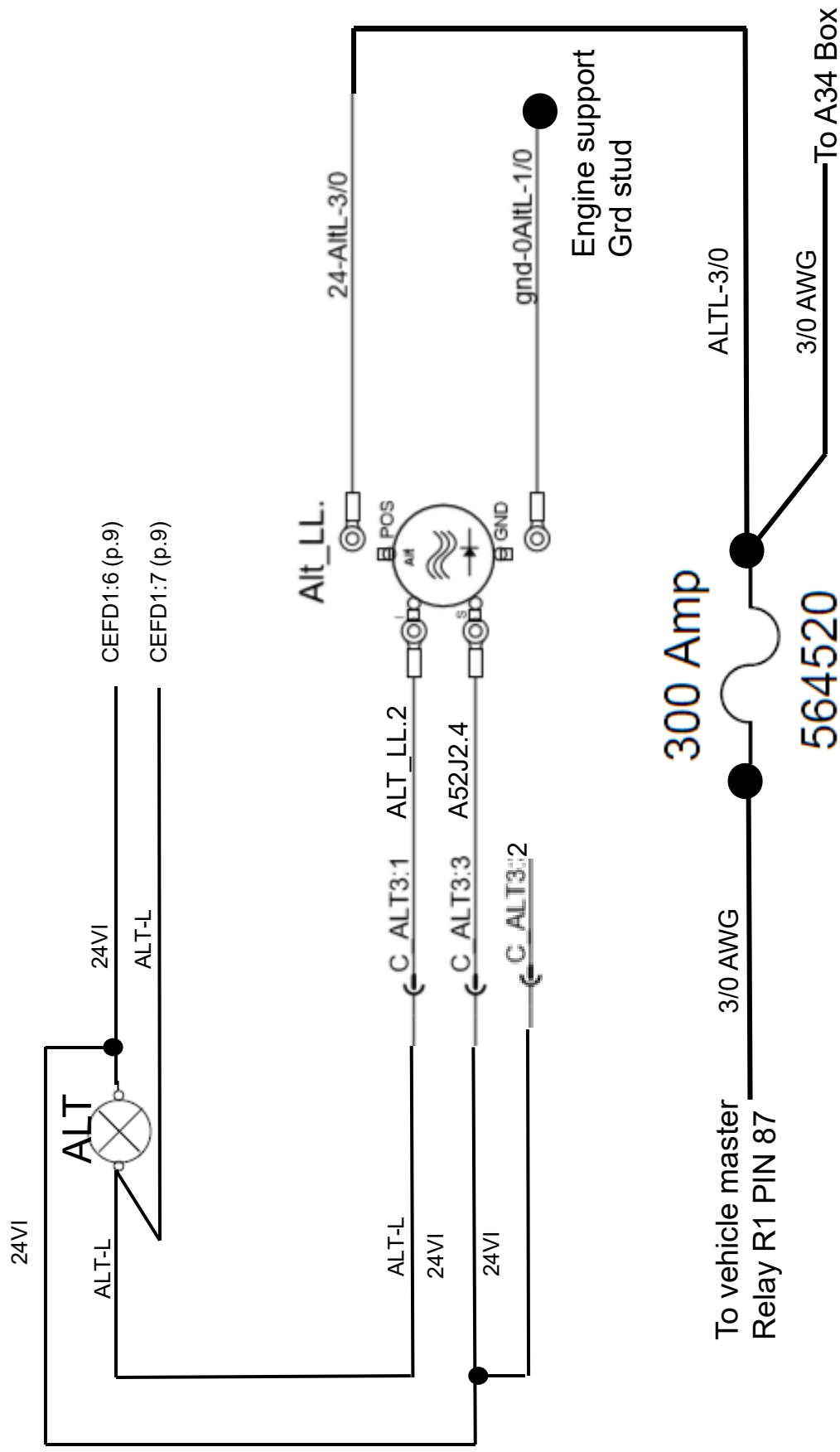

**THE ULTIMATE
EXPERIENCE**

PREVOST.

