

PREVOST

Instruction Sheet

IS-19900i

ELECTRIC FAN DRIVE COOLING SYSTEM CONVERSION WITH BOSCH ALTERNATOR

H3 coaches (2PCH...) US10 to GHG17 incl. (B-1721 to J-0184)

REVISION : i THIS DOCUMENT SUPERSEDES PREVIOUS VERSION.
June 17-20 Parts obsolete: 050303, 391028, 562112
Replaced by:
830165 24V RED TELLTALE LIGHT MODULE QTY: 1x
381594 BRACKET, TELLTALE QTY:1x
561540 TAB TERMINAL, ST,16-14,1/4 INS QTY: 2x
New holes drilled for cooling pack relocation

REVISION : H THIS DOCUMENT SUPERSEDES PREVIOUS VERSION.
Jan 24-20 Mention added stating to disable "Prime"

IMPORTANT NOTE

VEHICLES EQUIPPED WITH OPTIONAL PRIME ENERGY MANAGEMENT SYSTEM

TO PREVENT OVERLOADING THE L.H. SIDE ALTERNATOR, IT IS VERY IMPORTANT TO DISABLE « PRIME » SYSTEM ON VEHICLES RECEIVING THIS CONVERSION. PLEASE CONTACT YOUR NEAREST PREVOST SERVICE CENTER TO HAVE THE PRIME SYSTEM DISABLED. A SOFTWARE TOOL IS NEEDED TO DO SO.



MATERIAL





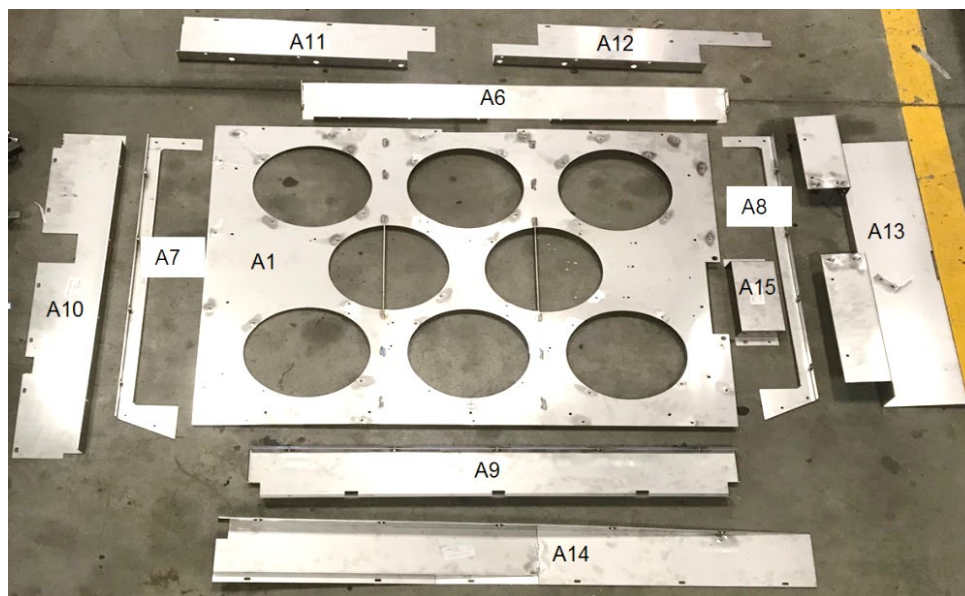

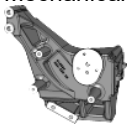
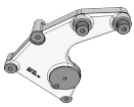

Kit **IS19900** contains the following parts:







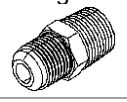
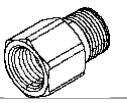
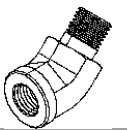
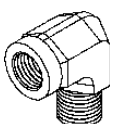

Part No.	DESCRIPTION		Qty
050195	FAN SUPPORT PANEL	A1	1
050200	UPPER SHROUD TRANSITION	A6	1
050201	LEFT SHROUD TRANSITION	A7	1
050202	RIGHT SHROUD TRANSITION	A8	1
050203	LOWER SHROUD TRANSITION	A9	1
050204	UPPER LEFT SHROUD PANEL H3 US10+	A11	1

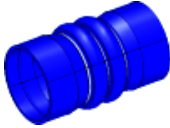





050229	ELECTRICAL CONNECTOR COVER	A15	1
050206	UPPER RIGHT SHROUD PANEL H3 US10+	A12	1
050213	LOWER SHROUD PANEL H3 US10+	A14	1
050208	LH SIDE SHROUD PANEL H3 US10+	A10	1
050255	RH SIDE SHROUD PANEL & WURTH BOX SUPPORT H3 US10+	A13	1



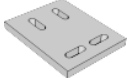
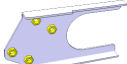







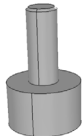

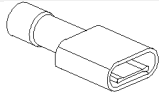





MECHANICAL			
012349	IDLER PULLEY	Mechanical 	1
012941	PULLEY, DRIVE	Mechanical 	1
012942	L.H. ENGINE MOUNT	Mechanical 	1
011213	SUPPORT, IDLER + TENSIONER	Mechanical 	1

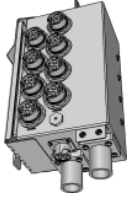



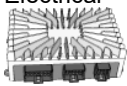
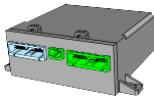

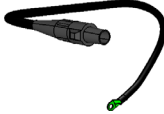
453076	CAP, DUST	Mechanical 	1
506026	1x BELT, DRIVE POLY V 10PK1695 1x BELT, DRIVE POLY V 10PK1695 (for your spare kit)	Mechanical 	2
510991	TENSIONER, BELT	Mechanical 	1
560748	BOSCH HD10PLBH ALTERNATOR 28V-150AMP J180	Mechanical 	1
0600265	PULLEY, ALTERNATOR 10PK, 73 DOB	Mechanical 	1
PIPES			
050286	CAC INLET PIPE H3 US10+	Pipe 	1
050406	CAC OUTLET PIPE H3 US10+	Pipe 	1
050414	RADIATOR INLET COOLANT PIPE H3 US10+	Pipe 	1
050288	RADIATOR OUTLET PIPE H3 US10+	Pipe 	1
501027	FITTING, SAE 45° #4FL-Mx1/4NPT-M BR	Fitting 	1
501308	ADAPTER / PIPE FITTING / 1/4NPT-Fx1/4NPT-M BR	Fitting 	1
501329	ELBOW 45° / PIPE FITTING / 1/4NPT-Mx1/4NPT-F BR	Fitting 	1
501332	ELBOW 90° / PIPE FITTING / 1/4NPT-Mx1/4NPT-F BR	Fitting 	1

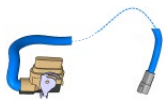
HOSES			
052366	HOSE 3/8 ID X 61 in LONG	hose 	1
030096	HOSE, FLEXIBLE - CHARGE AIR Location: turbo outlet & engine intake	Hose 	2
531469	HOSE, FLEXIBLE - CHARGE AIR Location: CAC outlet	Hose 	1
531471	HOSE, FLEXIBLE - CHARGE AIR Location: CAC inlet	Hose 	1
052889	HOSE, SILICONE 2 1/2" ID Location : coolant pipes	Hose 	1
053617	HOSE, SILICONE Location : coolant pipes	Hose 	3
CLAMPS+ SEALS			
21490616	CLAMPS, SPRING LOAD - CHARGE AIR Location: CAC outlet & inlet	Clamps 	8
21490630	CLAMP, SPRING LOAD - CHARGE AIR Location: turbo outlet & engine intake	Clamps 	4
992089	HOSE CLAMP CT CAILLAU 60mm-80mm Location : coolant pipes	Clamps 	16

992081	HOSE CLAMP CT CAILLAU 12-22 Location : coolant filter		4
SUPPORTS/BRACKETS			
21185073	MOUNT, ANTI-VIBRATION		1
050305	BRACKET, RADIATOR INLET PIPE		1
050265	COOLANT FILTER SUPPORT H3		1
050266	ALTERNATOR BATTERY CABLE SUPPORT		1
050214	UPPER RADIATOR SUPPORT H3		1
060102	ALTERNATOR BRACKET, LOWER		1
381594	U-SHAPED BRACKET, ALTERNATOR TELLTALE		1
MISC.			
010060	DECAL, BELT ROUTING		1
069205	DECAL, WARNING		2
506025	RUBBER EXTRUSION, BLACK		8 ft

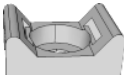
060297	STUD ADAPTER, ALTERNATOR M/F-M8	Misc. 	1
380360	GROUND STUD	Misc. 	1
506040	TAPE, ADHESIVE AD1 EPDM CC GY 5/16"X3/4"X25'	Misc.	1
21937327	FILTER, COOLANT	Misc. 	1
ELECTRICAL			
012921	GROUND STUD	Electrical 	1
561540	TERMINAL, TAB		2
561610	CONNECTOR HOUSING, PED WEATHER-PACK 4 WIRES	Electrical 	1
561783	CAVITY PLUG, CONNECTOR	Electrical 	4
563593	CONNECTOR, WITH END-OF-LINE 120 OHMS RESISTOR	Electrical 	2
563750	FUSE HOLDER, AMG TYPE	Electrical 	1
564520	FUSE, AMG 300A	Electrical 	1

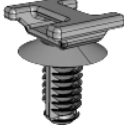
564612	CIRCUIT BREAKER BOX	Electrical 	1
565191	FAN, ELECTRIC	Electrical 	8
563533	HAND GUARD, FAN	Electrical 	8
830165	24V RED TELLTALE LIGHT MODULE		1
22722850	I/O-B MULTIPLEX MODULE	Electrical 	1
23499009-EFD	MCM, PROGRAMMED	Electrical 	1
HARNESSES			
068820	HARNESS, FAN DRIVE	Harness 	1
069246	GROUND CABLE, FAN DRIVE	Harness 	1
069504	GROUND CABLE, LEFT ALTERNATOR	Harness 	1
069511	CONTROL HARNESS, LEFT ALTERNATOR	Harness 	1
23445869	MCM TO I/O-B INTERFACE HARNESS	Harness	1
23488790	FAN TO RJB INTERFACE HARNESS H3	Harness	1
23490553	VEHICLE INTERFACE HARNESS	Harness	1

23498450	MASTER RELAY TO 300A FUSE CABLE, 300mm	Harness	1
23498721	FAN DRIVE POWER CABLE, 4600mm	Harness	1
23498785	L.H. ALTERNATOR POWER CABLE, 4450mm	Harness	1
HARDWARE MISC			
N37749	TIE, NYLON DOUBLE	hardware 	15
504016	TIE, NYLON BLACK (LARGE)	hardware 	58
504013	MOUNT, TIE HOLE 1/4"	hardware 	25
504751	MOUNT, TIE SWIVEL	hardware 	4
504750	MOUNT, TIE TREE	hardware 	1
509490	MOUNT, TIE DOUBLE GRAY	hardware 	15
509491	TIE, NYLON LARGE EXTRA STRONG 250 LBS	hardware 	38
562679	MOUNT, SQUARE SELF-ADHESIVE BLACK	hardware 	4
500449	WASHER, FLAT SS .687X1.5X0.078 (M16,5/8)	hardware	1
500482	WASHER, SPLIT LOCK Z050 .506X.873X.125 (M12,1/2)	hardware	1
500942	WASHER, SPLIT LOCK N500 8.1X14.8X2 (M8,5/16,#18)	hardware	4
502570	WASHER, SPLIT LOCK SS 6.1X11.8X1.6 (M6,#12)	hardware	62
502573	WASHER FL SS 6.4 X 12.0 X 1.6 (M6,1/4)	hardware	1

507657	WASHER, BANJO FITTING M14	hardware	8
5001341	WASHER, FLAT SS 8.4X17X1.6 (M8,5/16)	hardware	6
5001737	WASHER, SPLIT LOCK N500 10.2X18.1X2.2 (M10,3/8)	hardware	4
5001751	WASHER, FLAT N500 10.5X26X2 (M10,3/8)	hardware	10
5001833	WASHER, BELLEVILLE SPR SS 301 6.65X17.4X1.27(M6,1/4	hardware	32
5001868	WASHER, BELLEVILLE SS 8.4X18X2 (M8,5/16)	hardware	4
5001935	WASHER, FLAT SS 10.5X18X1.6 (M10,3/8)	hardware	1
5002008	WASHER, FLAT HARD N500 13X35X5 (M12,1/2)	hardware	1
500998	NUT HEX BR 1/2-13	hardware	1
502837	NUT HEXF STO N500 M8-1.25	hardware	2
502859	NUT HEX NYRT NX500 M10-1.5 G10	hardware	4
5001182	NUT HEX NYRT SS M6-1	hardware	1
5001665	NUT HEX NYRT NX500 M22-2.5	hardware	1
5001728	NUT HEXF STO N500 M12 CL10	hardware	1
5001761	NUT HEXF NYRT NX500 M12-1.75 G8	hardware	2
5001930	NUT HEXF NYRT NX500 M10-1.50 PC 10	hardware	2
5001983	NUT HEX NYRT NSS M8-1.25X9.5	hardware	3
21429955	NUT, FLANGED	hardware	1
500119	SCREW, CAP HEX SS NSS M8X1.25X20	hardware	4
500658	SCREW TC PAN PH Z050 10-24X3/4	hardware	11
502719	SCREW, CAP HEX SS NSS M10X20 G8.8	hardware	1
502686	SCREW, CAP HEX SS NSS M6X30	hardware	33
502804	SCREW, CAP HEX N500 M10-1.5X25 G8.8	hardware	8
502848	SCREW TC HEX F N500 1/4-20X3/	hardware	22
502950	SCREW SHR HEXF N500 12.9X160LG CL10.9	hardware	1
5001296	SCREW, CAP HEXFN500 M12-1.75 X 80 CL10.9 PT	hardware	6
5001643	SCREW, CAP HEXF G500 M8-1.25X25 G8.8 PT	hardware	3
5001697	SCREW, CAP HEX SS NSS M6X16	hardware	62

5001738	SCREW, CAP HEX N500 M8X30 G8.8 FT	hardware	4
5001745	SCREW, CAP HEX N500 M8-1.25X25 G8.8	hardware	2
5001786	SCREW, CAP HEXF AD N500 M12-1.75X30 G8.8	hardware	1
5001799	SCREW, CAP HEXF N500 M10-1.5 X 70 G10.9	hardware	4
5001800	SCREW, CAP HEXF N500 M10X45 G10.9	hardware	1
5001940	SCREW CAP HEX N500 M12X1.75X140	hardware	2
RIVETS			
504379	RIVET, POP DOME SS OE 3/16X1/4		41
504610	RIVET MGL PRDG SS 1/4X5/8		14
IS-19900	INSTRUCTION SHEET		1
FI-19900	FEUILLE D'INSTRUCTION		1

Other parts or products that may be required:

Part No.	DESCRIPTION
680459	LOCTITE 404, INSTANT ADHESIVE 9.3gr
680098	LOCTITE 567 THREAD SEALANT 250ML
680038	LOCTITE 243, BLUE THREADLOCKER 50ML
684013	LOCTITE COLOR GUARD RUBBER COATING

PREVOST

PROCEDURE



DANGER

Park vehicle safely, apply parking brake, stop engine. Prior to working on the vehicle, set the ignition switch to the OFF position and trip the main circuit breakers equipped with a trip button.

DIAGRAM OF ELECTRICAL CONNECTIONS

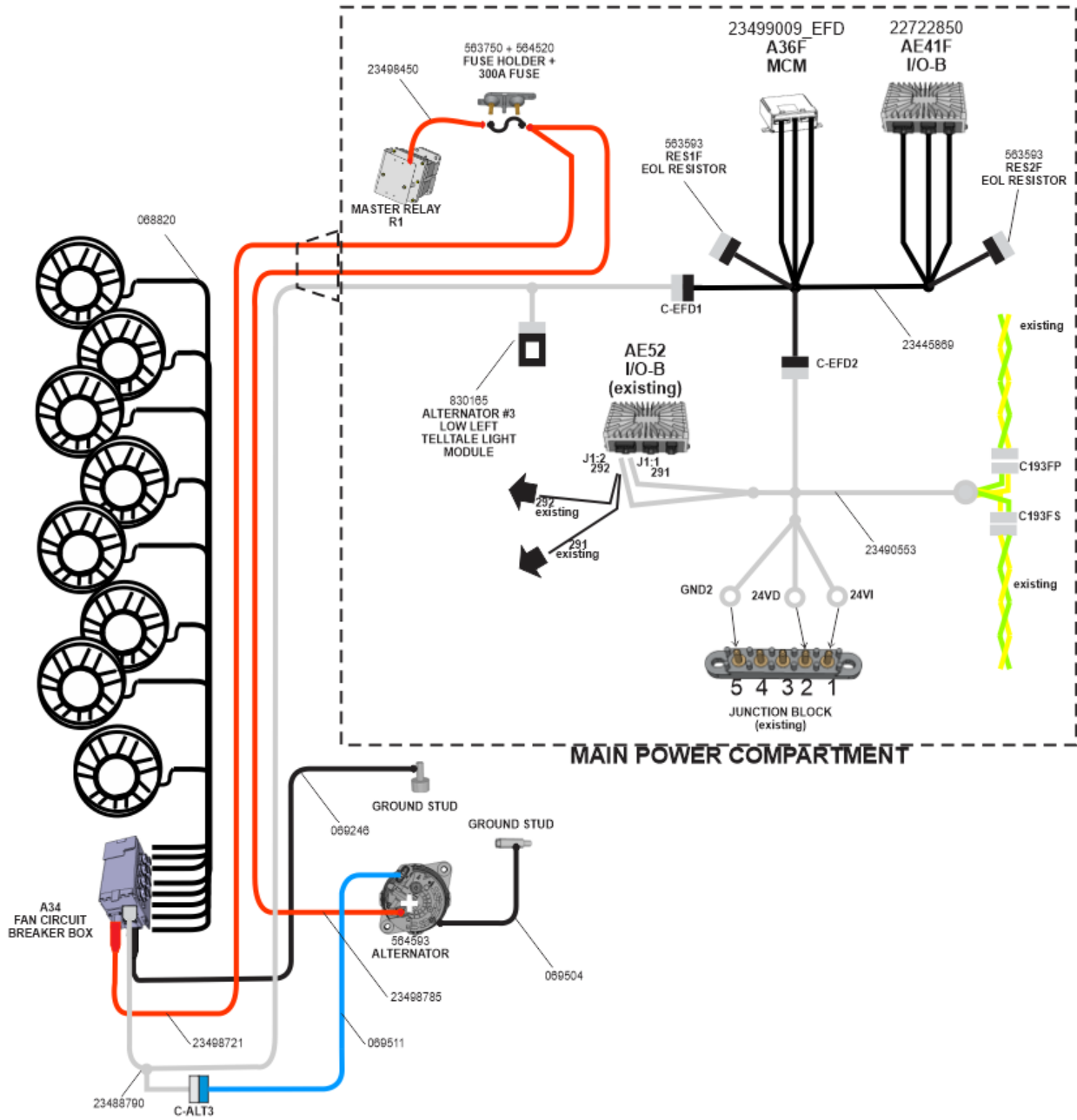

PREVOST

HOSE CLAMP TORQUE (coolant lines and charge air cooler)

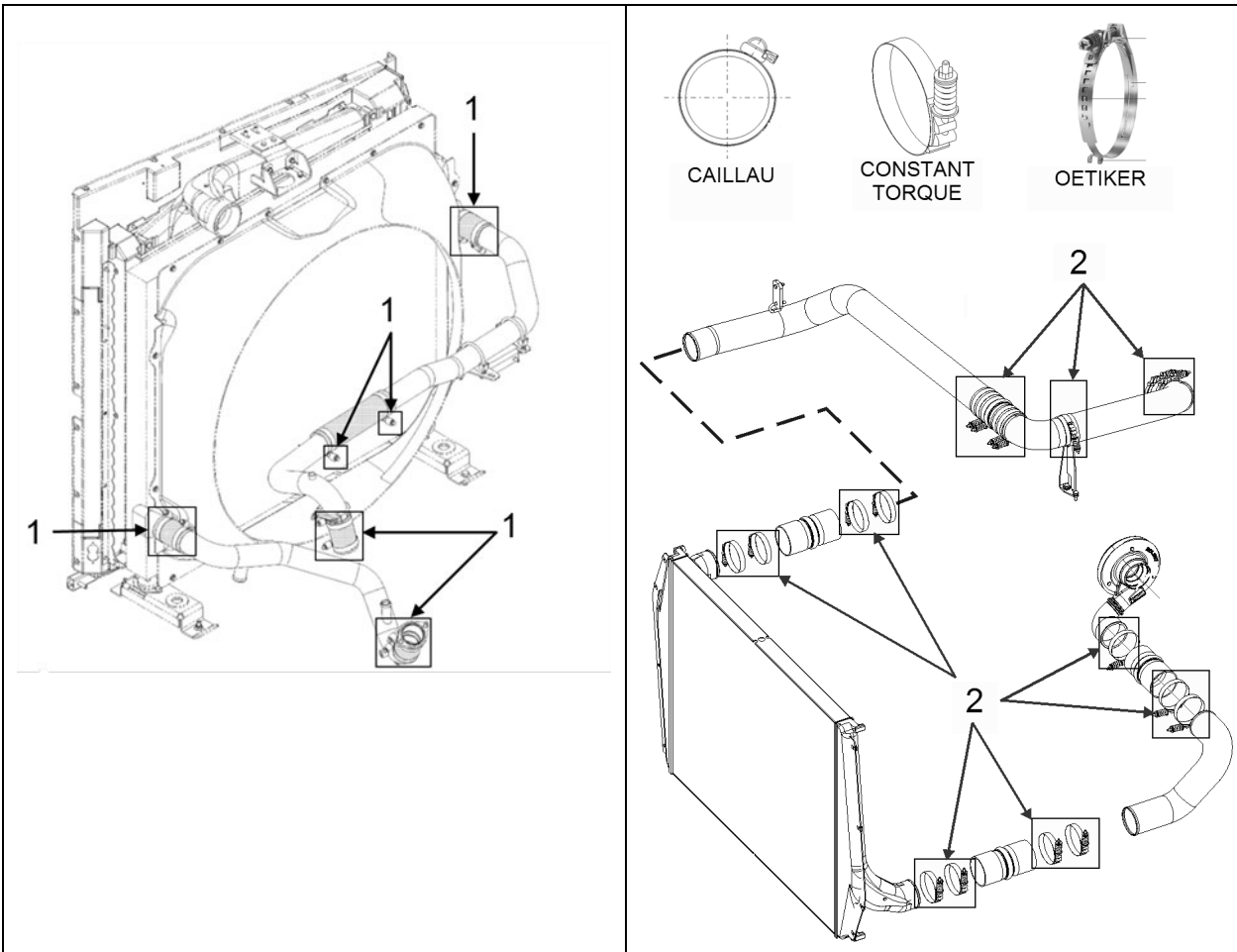

HOSE CLAMPS

No	DESCRIPTION	TORQUE
1 (Ø 2 ½" or less)	Constant-Torque hose clamps - coolant lines Oetiker hose clamps – Green spring - coolant lines Oetiker hose clamps – unpainted spring - coolant lines Caillau hose clamps - coolant lines	90-100 lbf-in 12-18 lbf-in 8-9 lbf-in 30 lbf-in
2 (Ø 4 ¼")	Constant-Torque hose clamps 4.25in - charge air cooler (CAC)	4.5-5.5 lbf-ft

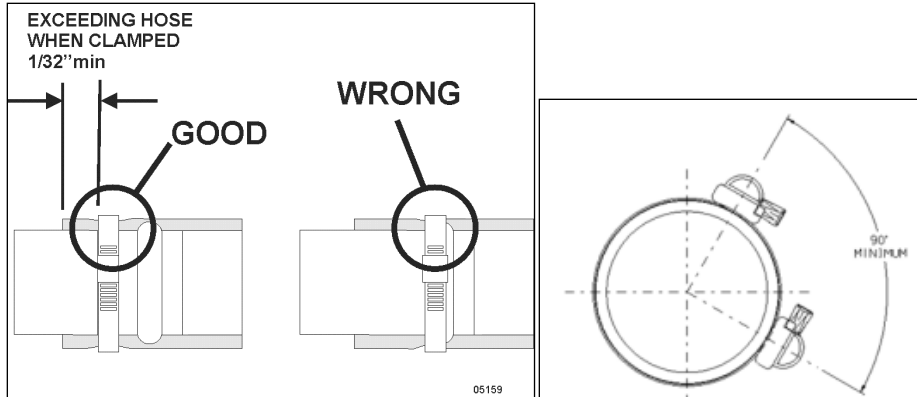

PREVOST

1. In the main power compartment, place the battery master switch to the OFF position. Trip all the main breakers that have a manual trip feature (CB2, CB4, CB6, etc...depending on the year model).

2. Remove L.H. side rear fender.

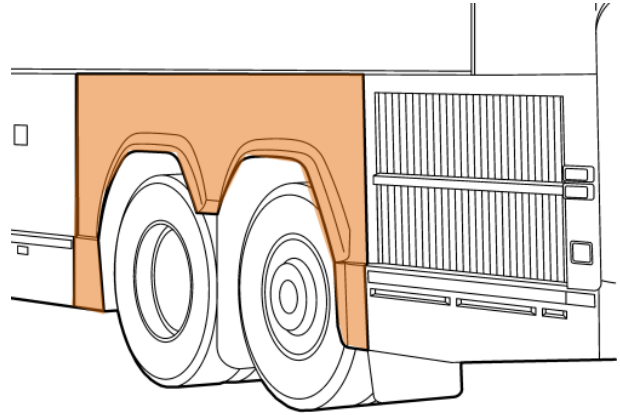

FIGURE 1

Drain the cooling system

3. Connect the coolant extractor. Use the coolant extractor to drain the coolant from the engine. An alternate method is to drain the coolant into a suitable container using the drain hose.

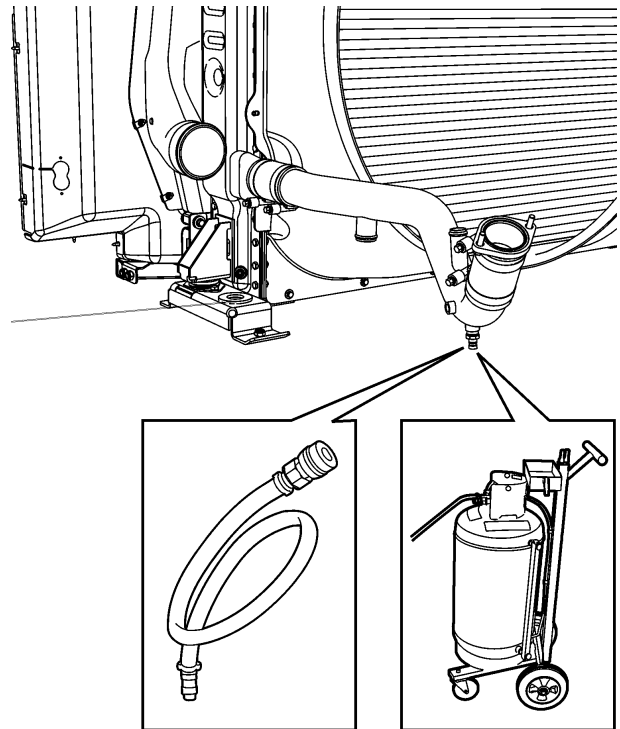

FIGURE 2

4. Unfasten cap screws and remove **access panel** located behind tag axle L.H. side wheel.

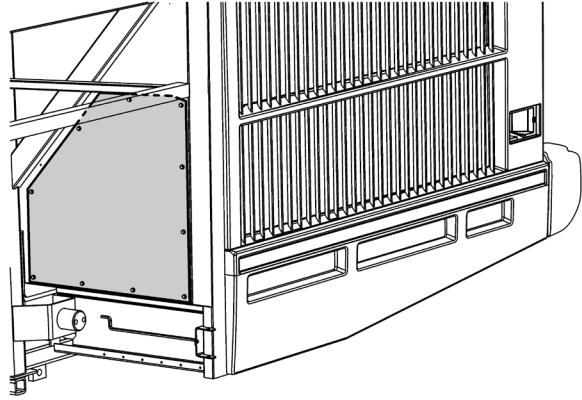

FIGURE 3

5. Open radiator door to access radiator assembly.
Unfasten **upper arm assembly**.

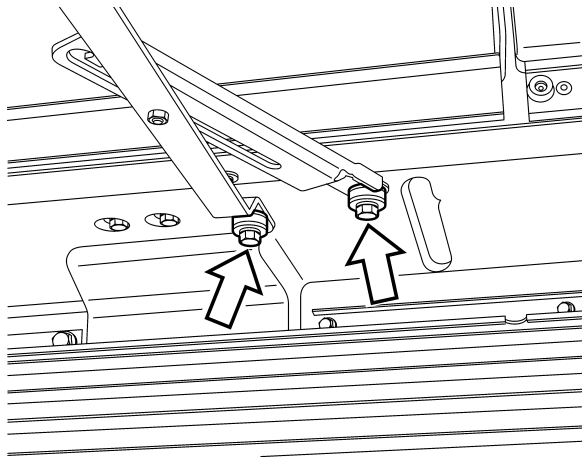

FIGURE 4

6. Remove radiator **sealing frame**.

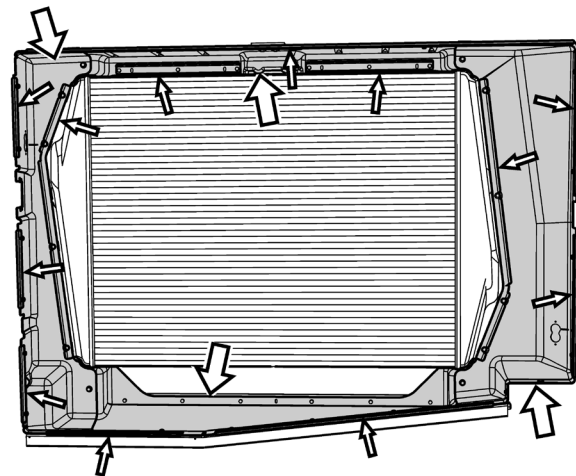

FIGURE 5

7. **Remove clamps** and then break hoses from the front coolant and charge air pipes.

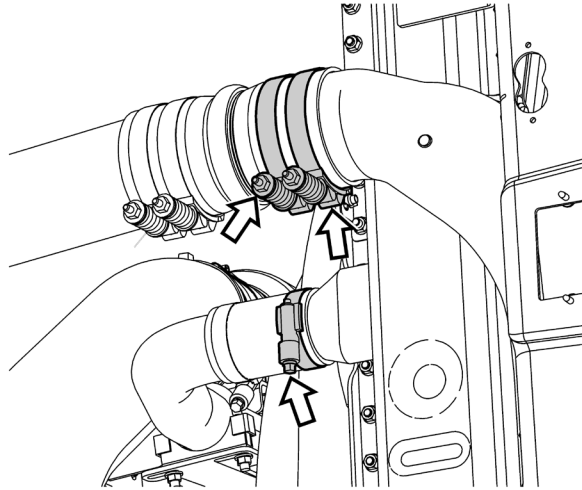

FIGURE 6

8. **Remove rear coolant and charge air hose clamps** then break hoses loose.

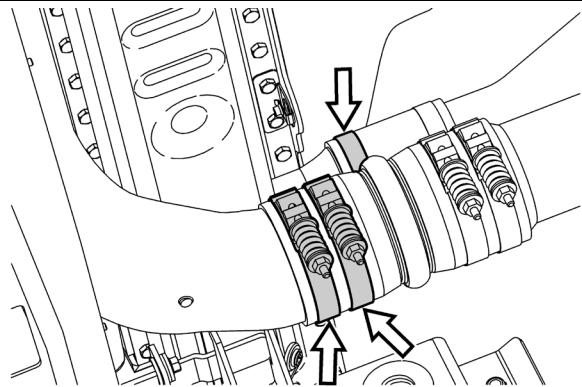

FIGURE 7

9. Remove the upper radiator assembly **support bracket**.

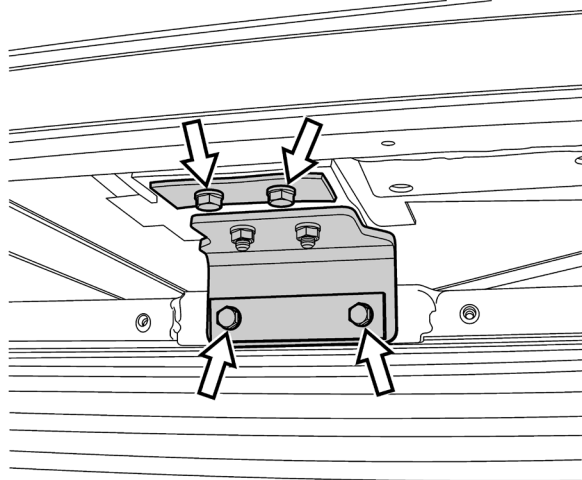

FIGURE 8

10. Remove the lower radiator assembly protector tube.

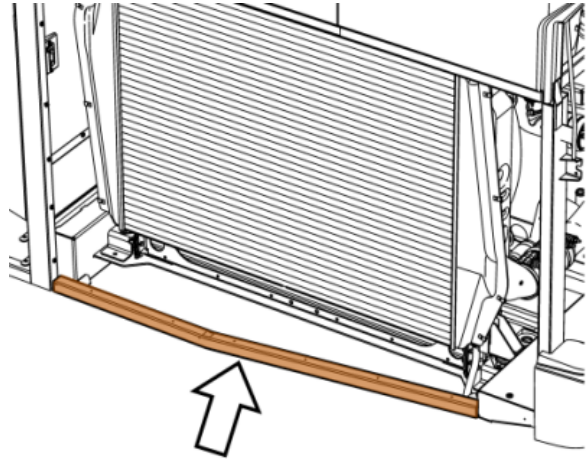

FIGURE 9

11. Disconnect the **radiator vent hose** on top of the radiator.

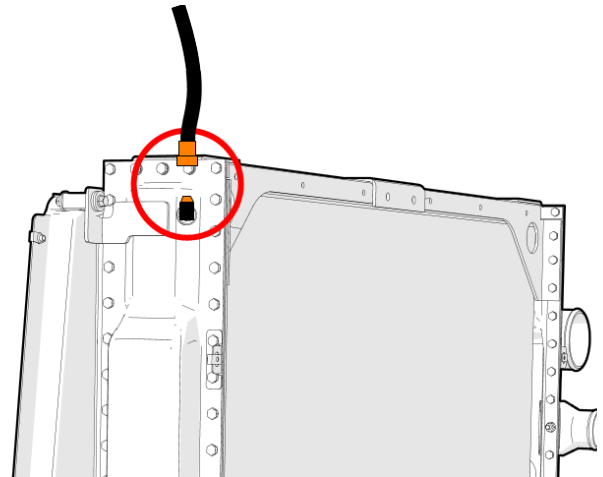

FIGURE 10

12. Cut the cable tie and disconnect **electrical connector** from the fan clutch. The remaining connector on the chassis cable will be capped and left in place.

13. Remove fan **drive shaft** fasteners at the fan clutch.

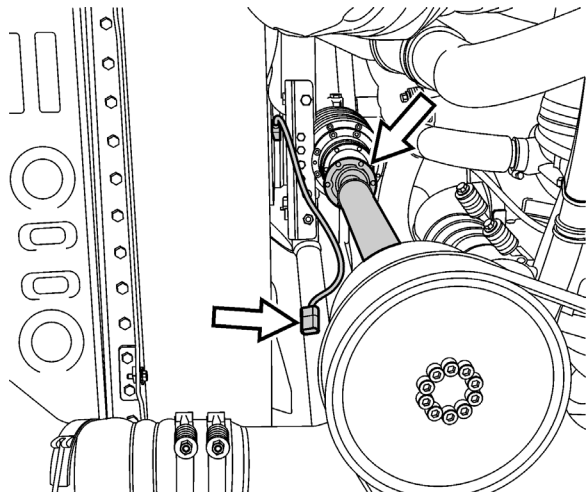

FIGURE 11

14. Open the secondary lock of **connector #561610**. Insert a **cavity plug #561783** in each of the four (4) cavities with the smallest end protruding as shown on the example at right. Close the secondary lock.



FIGURE 12

15. Cap the chassis fan clutch cable with this connector. Secure the connector on the inner wall above the radiator using:

- **1x tree mount #504750**
- **1x nylon tie #504016**



FIGURE 13



FIGURE 14

16. Remove the fan drive casting.



FIGURE 15

-
17. Unscrew all lower radiator assembly **mounting fasteners** (2 bolts on R.H. side, 2 bolts on L.H. side).

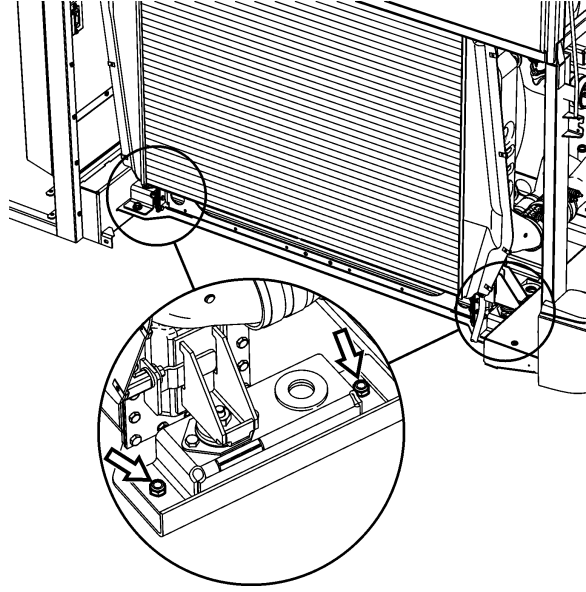

FIGURE 16

-
18. Position a **forklift** under the radiator assembly that is capable of safely lifting the radiator. With assistance, slide radiator assembly out and onto the forklift. Transfer radiator assembly to a secure location.

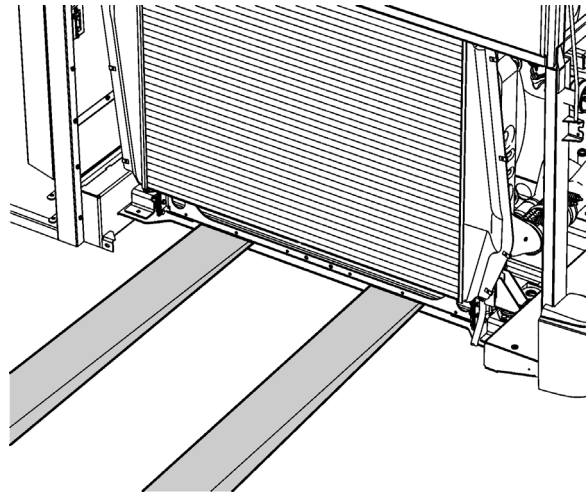

FIGURE 17

19. **Remove** the **tripod** from the radiator/CAC assembly.

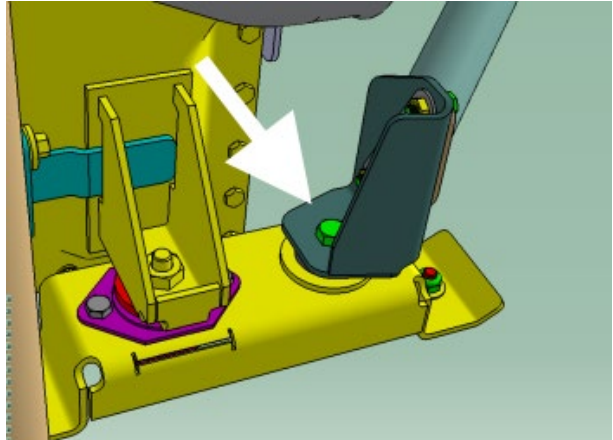

FIGURE 18

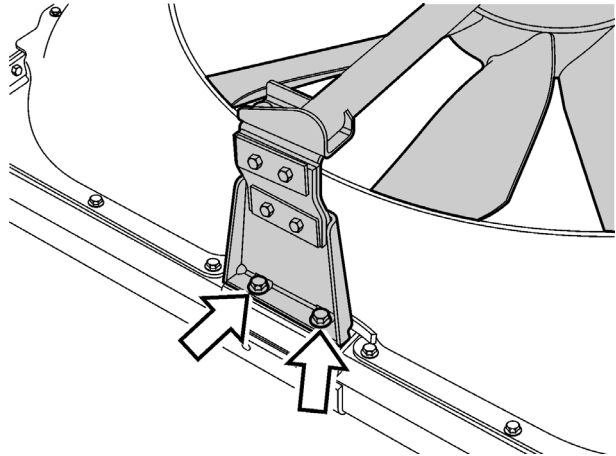

FIGURE 19

20. **Remove** the fan **shroud**.

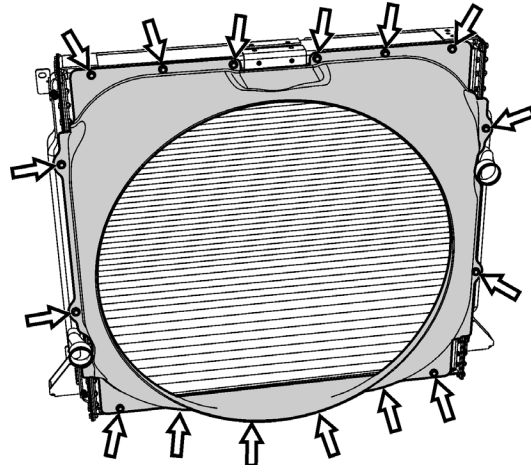

FIGURE 20

21. The new cooling pack arrangement requires being located closer to the engine to give the needed clearance for the electric fans. For this reason, **rotate** both the cooling pack **mounting support 180°** and reinstall.

BEFORE

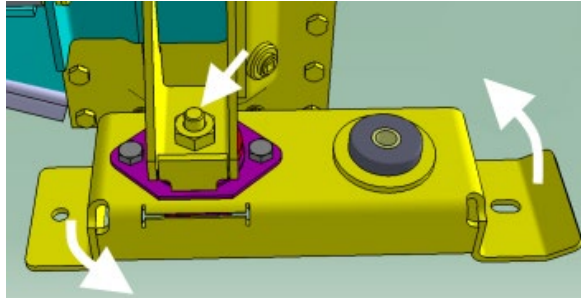

FIGURE 21: MOUNTING SUPPORT IN INITIAL POSITION

AFTER

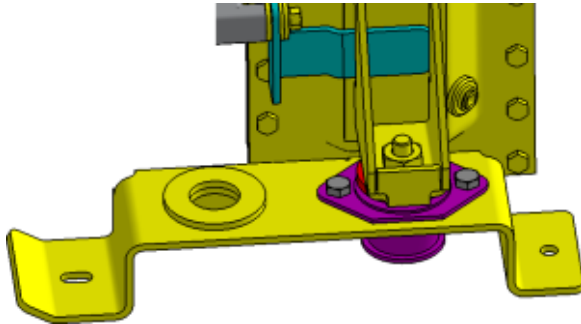

FIGURE 22: MOUNTING SUPPORT AFTER 180° ROTATION

22. Drill two (2) new holes for both cooling pack mounting supports at $\frac{3}{4}$ inch (19 mm) from the previous holes, towards the engine.

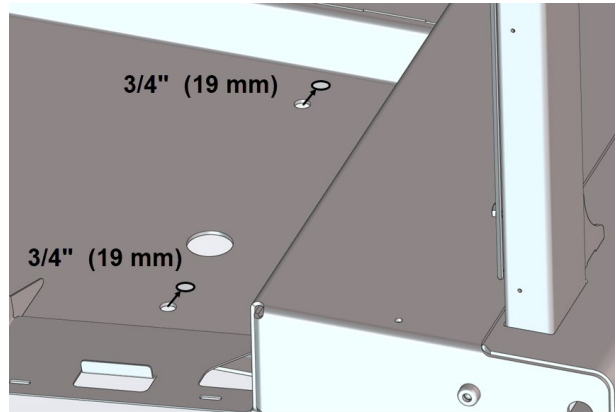

FIGURE 23: NEW HOLES FOR THE COOLING PACK MOUNTING SUPPORTS

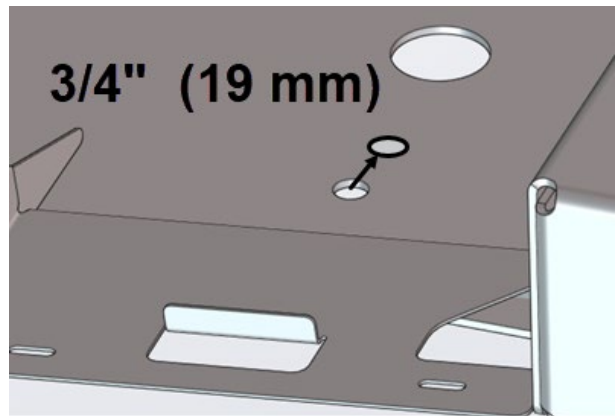

FIGURE 24: NEW HOLE FOR THE COOLING PACK MOUNTING SUPPORTS (DETAIL VIEW)

23. Remove the **rear bumper** (undo three nuts and one attachment plate each side).

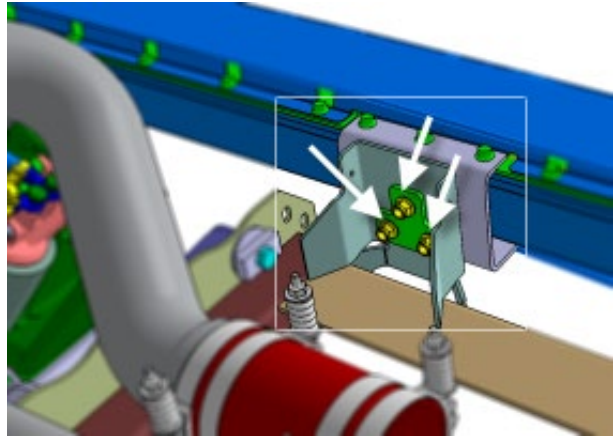

FIGURE 25

24. On the engine hot side, remove the following pipes:

- radiator inlet & outlet pipes
- CAC inlet and outlet pipes

Keep the fittings found on the radiator outlet pipe for reuse

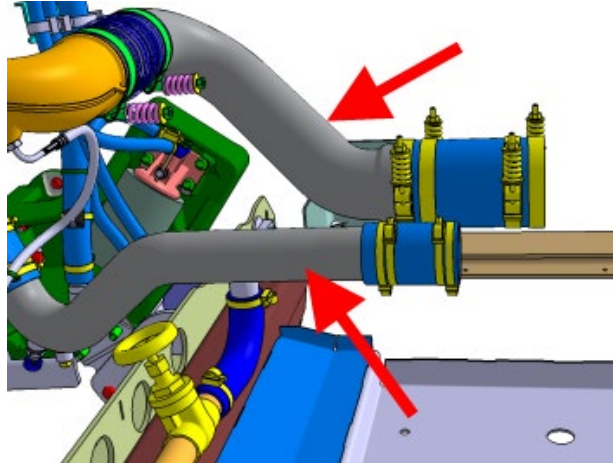

FIGURE 26

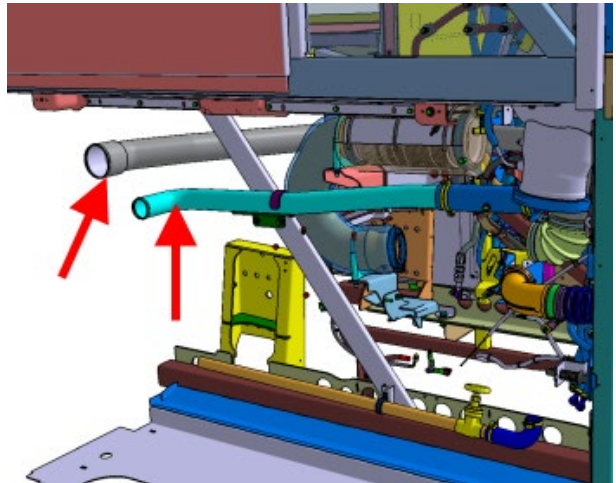

FIGURE 27

25. Remove all the drive belts mounted on the crank pulley.

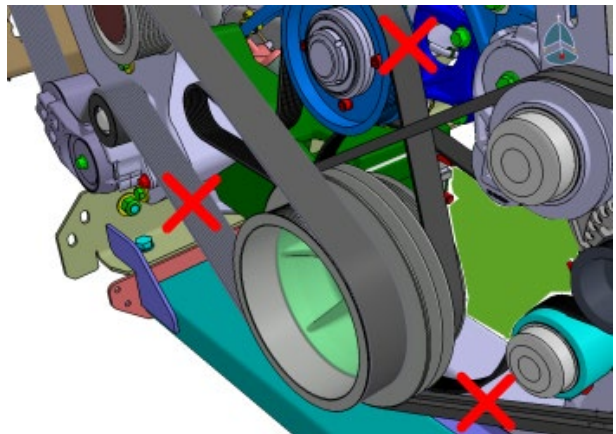

FIGURE 28

26. Remove the drive pulley. Discard the 6 bolts.

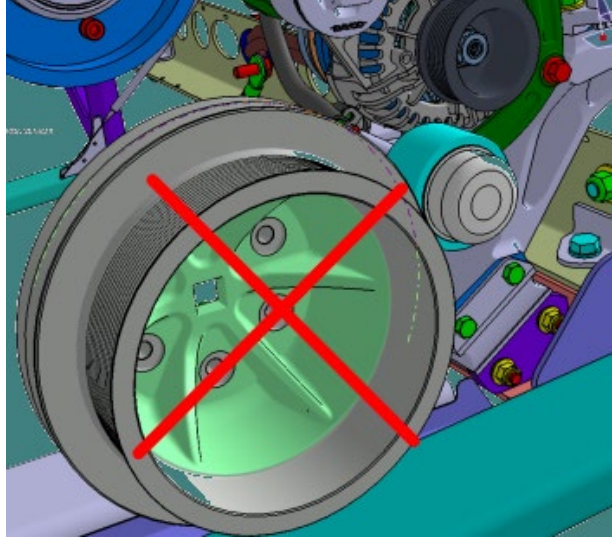

FIGURE 29

27. Remove the rust, clean and prepare the surface on the vibration damper as shown. Work the surface to achieve a smooth finish.



FIGURE 30



FIGURE 31

28. Properly support the engine as one of the engine support will be interchanged in the upcoming steps.



FIGURE 32

29. Remove the two (2) coolant hoses shown on the image. Keep the two (2) banjo fittings for later use.



BANJO FITTING

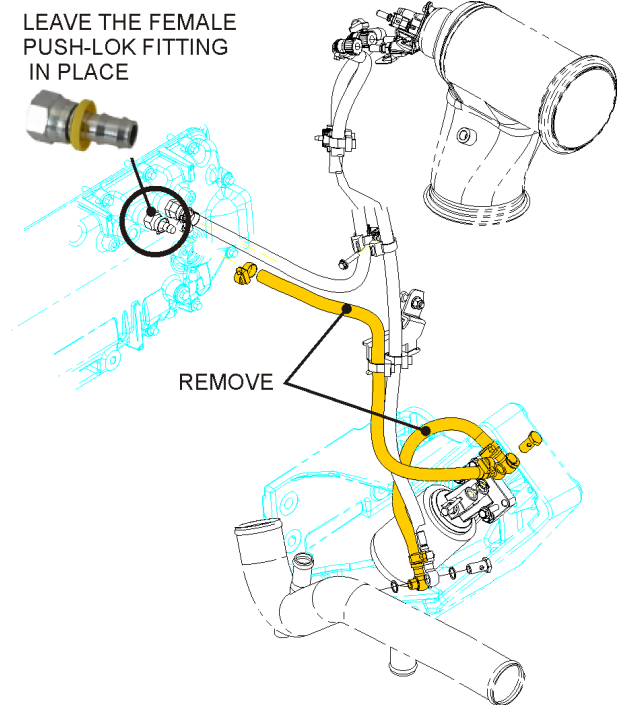

FIGURE 33

30. Remove the L.H. rear engine support (10 bolts). Keep the hardware for reinstallation.

Take note that the water pump belt idler/tensioner assembly will be reused as is. Do not take apart tensioner or idler.

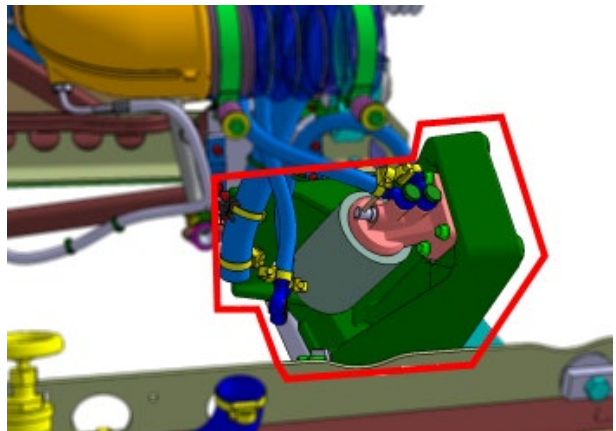

FIGURE 34: L.H. REAR ENGINE SUPPORT

31. Remove the water pump idler/tensioner assembly from the former engine mount. To do so, unscrew three (3) bolts from the back of the engine mount.

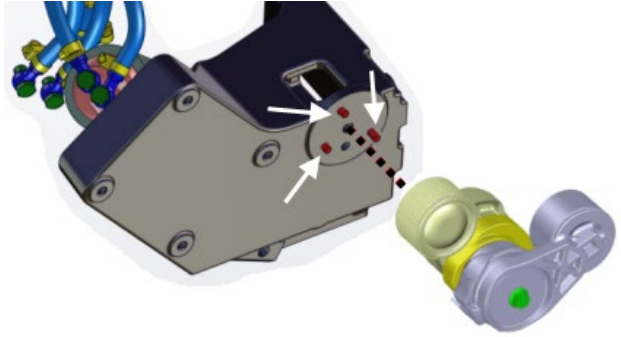

FIGURE 35

32. Reinstall idler/tensioner assembly as a unit on the new L.H. engine mount #012942.

Mount the idler/tensioner assembly using three (3) cap screws #5001643

Tighten to 14-17 lb-ft

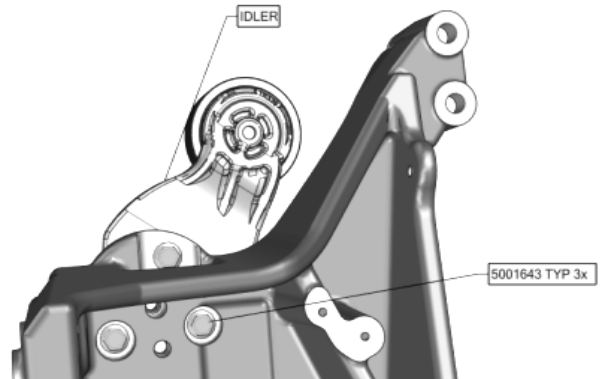

FIGURE 36

33. Install the new engine mount #012942 using seven (7) M14 screws saved from the former engine support with this exception of:

- **Ground stud #012921 (1x) and nylon insert NYRT nut #5001665 (1X)**
- **Isolator cap screw #5001940 (2X)**
- **Nut #5001761 (2X)**

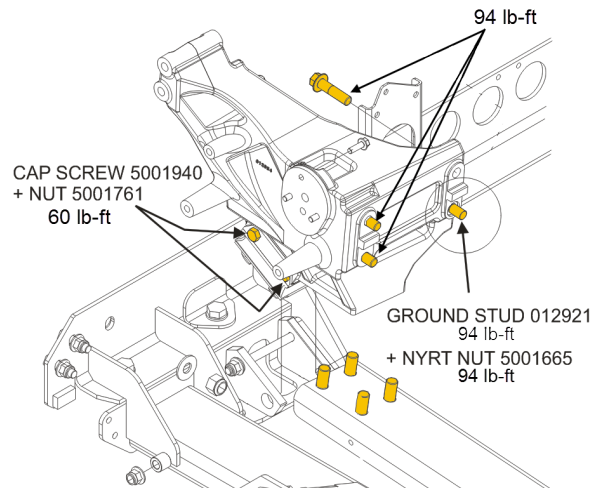

FIGURE 37

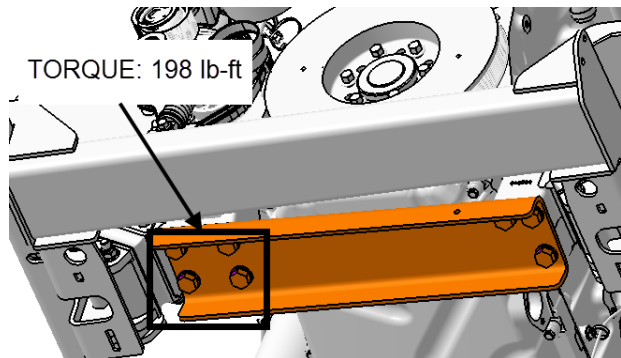

FIGURE 38: FOUR (4) SCREWS UNDER THE REINFORCEMENT CHANNEL

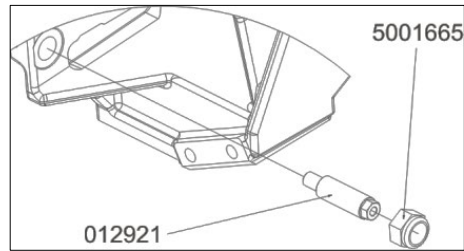

FIGURE 39: REAR VIEW – GROUND STUD

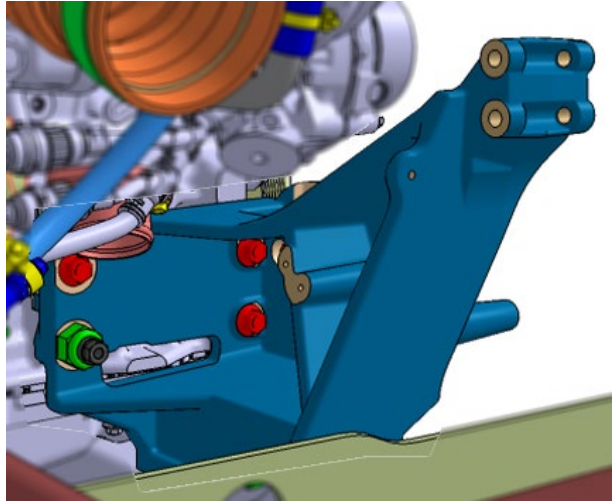

FIGURE 40

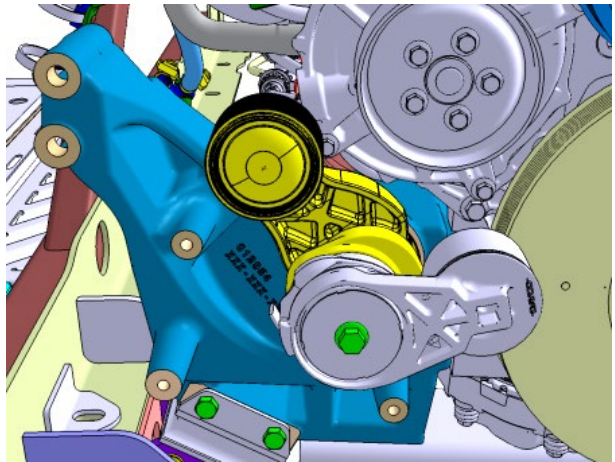

FIGURE 41

34. Install the new crank pulley using six new bolts #5001296. Use blue Loctite on the bolt threads.

Torque to 26 lb-ft in the numerical order 1, 2, 3, 4, 5, 6, 1

Once done perform a final tightening to the value of 66 lbf-ft.

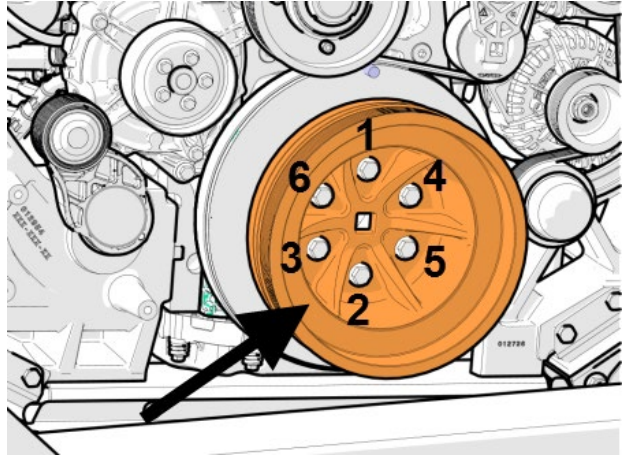

FIGURE 42

35. Reinstall the water pump drive belt.

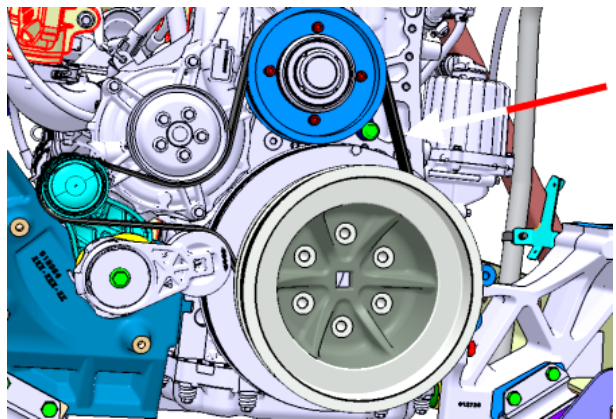

FIGURE 43: WATER PUMP DRIVEBELT

36. Reinstall the AC compressor drive belts.

37. Install the idler support #011213 using three (3) screws #5001799. At the same time, install the alternator lower bracket #060102.

screws #5001799 prescribed torque:48 lbf-ft

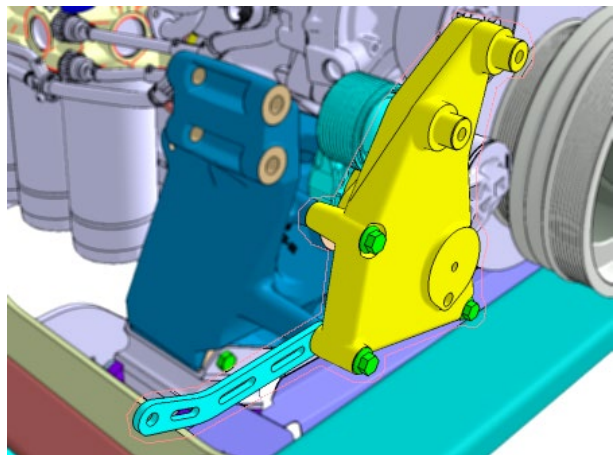

FIGURE 44: BRACKET #060102

38. Make a smooth round clearance in the engine cradle to allow required space for the alternator lower bracket #060102 installed at the previous step. Carefully work the edge to achieve a smooth finish and contour.

Measurements: \leftrightarrow 2", \updownarrow $\frac{3}{4}$ "

Apply paint to protect the metal against corrosion

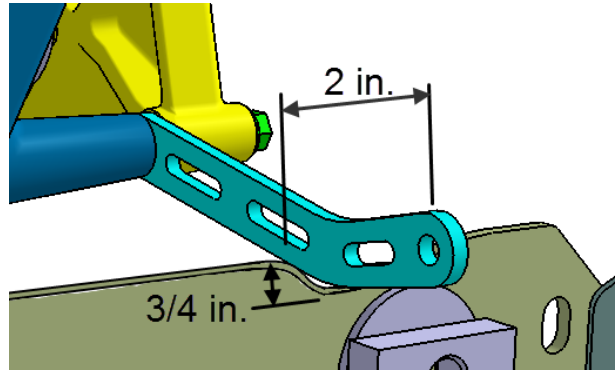

FIGURE 45

39. Install the new idler #012349 with screw #5001786 and washer #5002008.

Tighten to 59 lb-ft

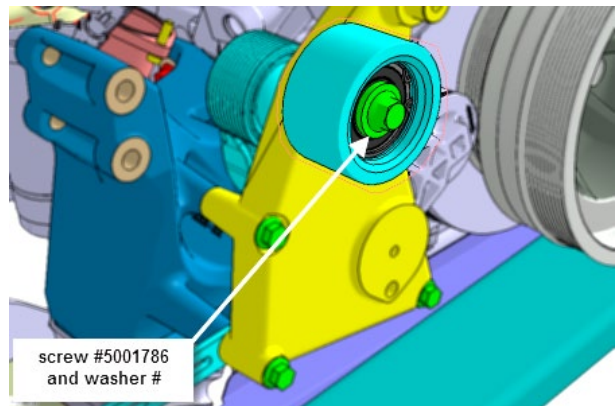

FIGURE 46

40. Install the dust cap #453076.

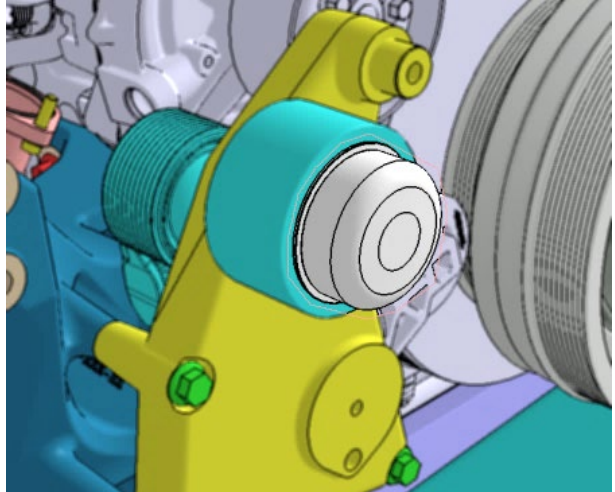

FIGURE 47



FIGURE 48

41. Install the new alternator belt tensioner #510991. Secure with one screw #5001799 on which **blue Loctite** is applied on the threads.

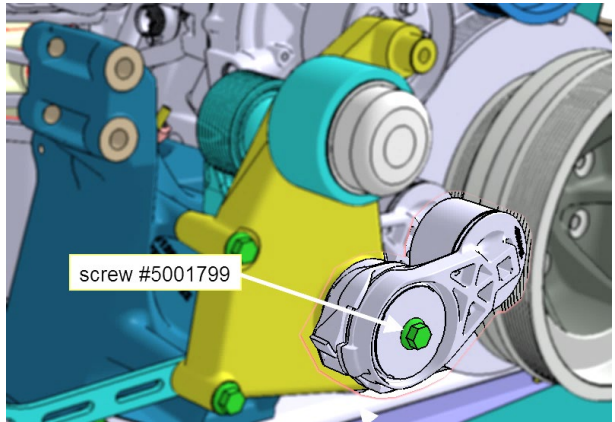

FIGURE 49: TENSIONER MOUNTING SCREW TORQUE : 48
lb-ft

42. Apply anti-seize compound (Prevost p/n: 680335) inside the alternator mounting ears and inside the sleeves found on the support attached to the engine.

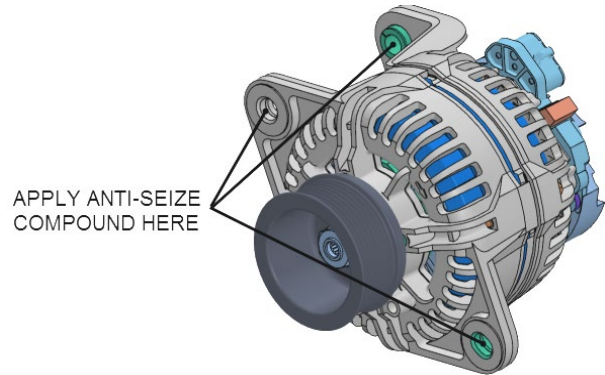

FIGURE 50

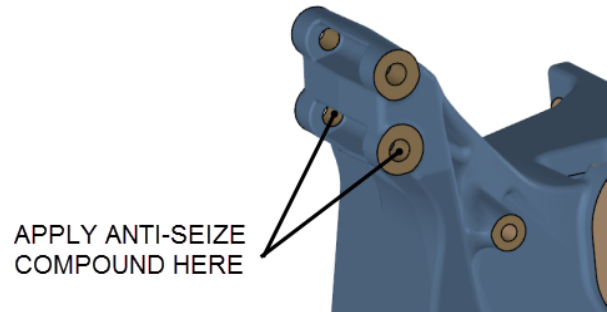

FIGURE 51

43. Install the alternator.

A: screw #502950 & nut #5001728 (torque: 82 lbf-ft)

B: screw #5001800 & nut #5001930 (torque: 48lbf-ft)

C: apply blue Loctite and then torque to 48 lbf-ft

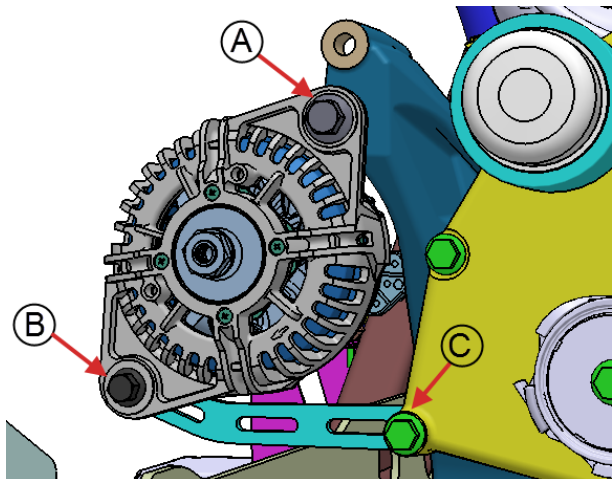

FIGURE 52

Simultaneously, install the alternator “power cable” support #050266 to the alternator as shown on the picture.



FIGURE 53

44. Install the alternator pulley #0600265 (for further details, refer to Maintenance Information IM16-17).

Use washer #500449 and flanged nut #21429955

torque: 75 lbf-ft

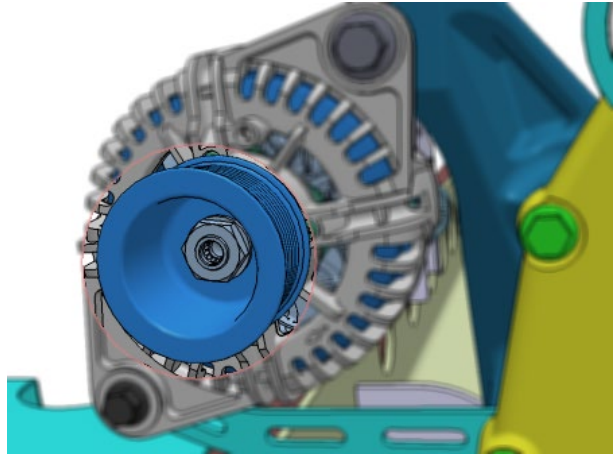

FIGURE 54

45. Install the alternator drive **belt** #506026.

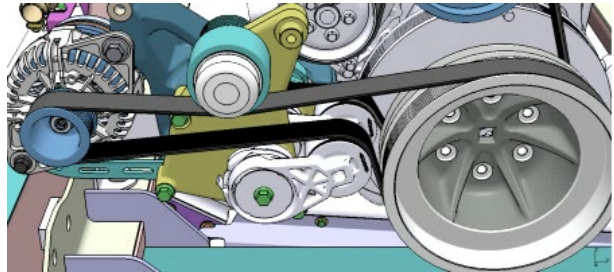

FIGURE 55

46. On the alternator, install the stud adapter #060297 at **B1+** stud terminal.

torque: 11 lbf-ft

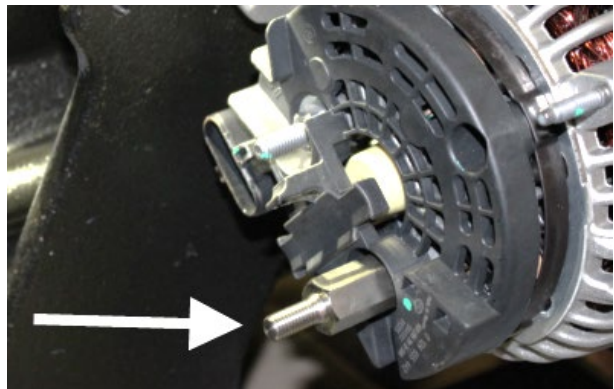

FIGURE 56

47. Perform the "Multiplex Modules Disconnection Procedure Prior to Welding" found in your vehicle Maintenance Manual, Section 00: General.
48. Weld the new coolant filter support #050265 on the engine cradle.

23 1/2 inches from the end of the cradle

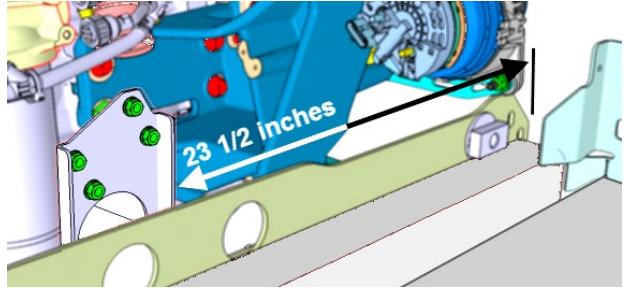

FIGURE 57

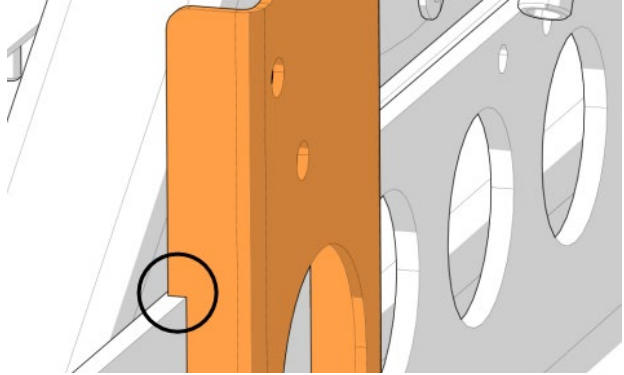

FIGURE 58

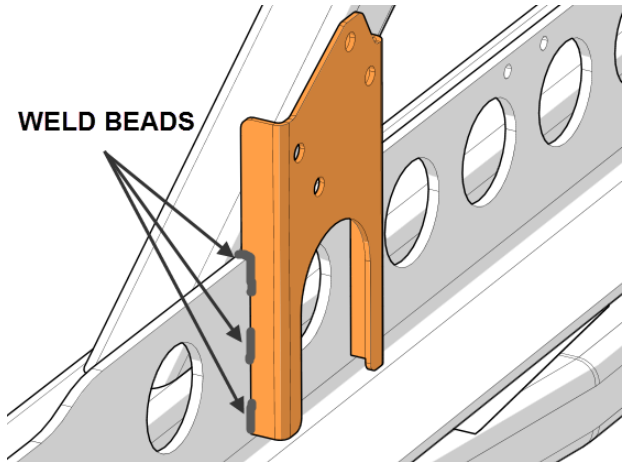

FIGURE 59

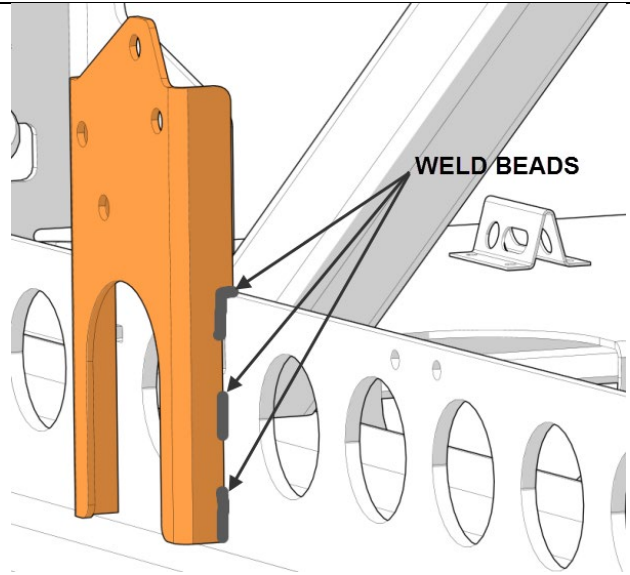

FIGURE 60

49. As a preparation to **welding**, use a grinder with abrasive disc to remove some paint to reach bare metal. Weld the **ground stud #380360** centered in the beam and at 14 inches from the beam end.

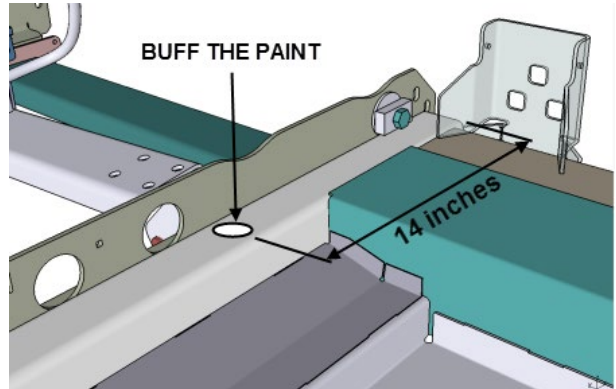

FIGURE 61



FIGURE 62: GROUND STUD #380360

50. Apply black paint to the area surrounding the ground stud and the ground stud circular base. **DO NOT** apply paint on the electrical contact surfaces.

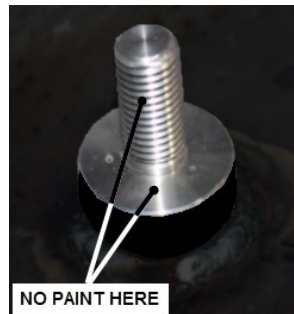

FIGURE 63: GROUND STUD #380360

51. Install a tie mount #509490 with one screw #502686 at the back of the L.H. engine mount.



FIGURE 64

-
52. Install the alternator ground cable #069504. Secure to the ground stud on the alternator using washer #502573 and nut #5001182.

torque: 6 lbf-ft

53. Secure the alternator ground cable to the previously installed tie mount using one nylon tie #509491.



FIGURE 65

-
54. Secure the alternator ground cable #069504 to the previously installed ground stud on the L.H. engine mount.

Use screw #502719 & washer #5001935

torque: 20 lbf-ft

Protection against corrosion. Apply Color Guard rubber coating on the ground stud once the ground cable is hooked up.

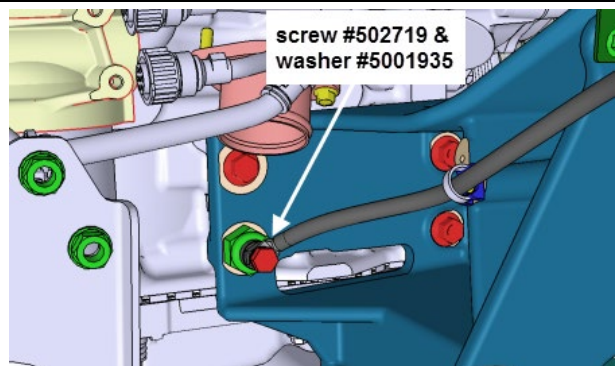

FIGURE 66

-
55. To the previously installed coolant filter support, install the filter holder recovered from the former installation.

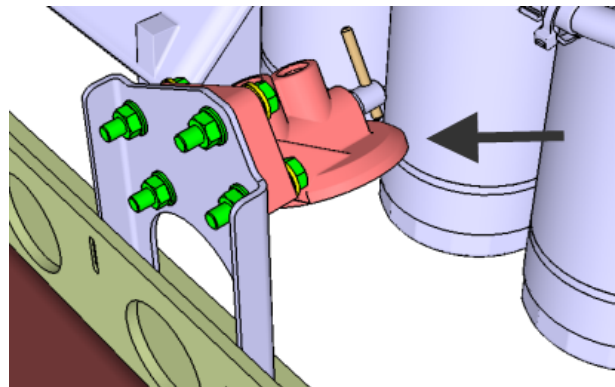

FIGURE 67

-
56. Install a new coolant filter onto the filter holder. Check the clearance between the filter and the near hose clamps of the coolant pipe leading to the transmission oil cooler.
-

57. Transfer the drain plug and the coolant extractor quick connect fitting saved from the old radiator outlet pipe.

Apply Loctite 567 Thread Sealant prior installation of the fittings

58. Install the new radiator outlet pipe #050288. Reinstall with the flexible hose #053617 and four (4) hose clamps #992089. Use steel wire to hold the end of the pipe until the radiator is installed if required.

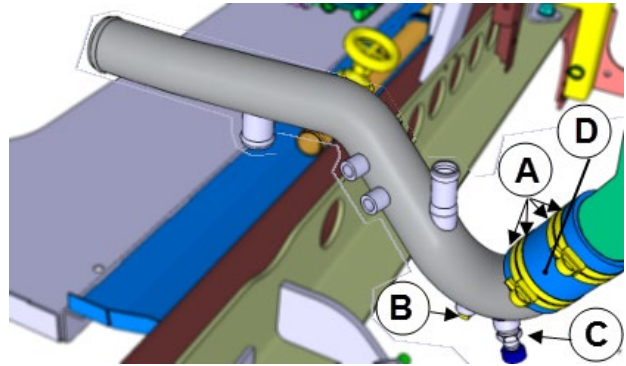

FIGURE 68

A: # 992089 hose clamp (4x); torque: 30 lbf-in

B: drain plug

C: coolant extractor quick connect valve

D: # 053617 silicone hose

59. Reinstall the elbow between the copper heater line and the new radiator outlet pipe.

For proper clamp torque, refer to HOSE CLAMP TORQUE on page 12.

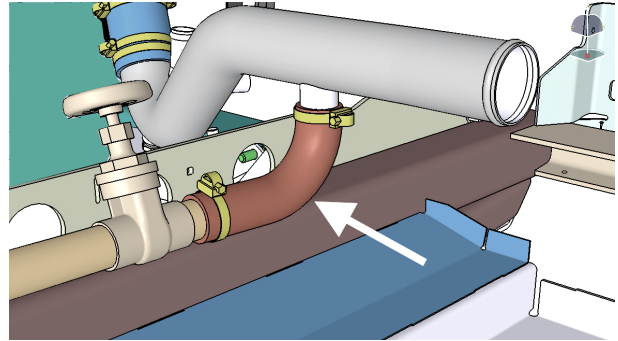

FIGURE 69

60. Using blue flexible hose #052366, prepare two new short hoses for the coolant filter.

a) Cut two sections of blue flexible hose, one **22 inches** long and a second one, **38 inches** long.

A : hose clamp #992081 (4x)

B: banjo fitting copper washer #507657 (6x)

blue hose 22" long (new)

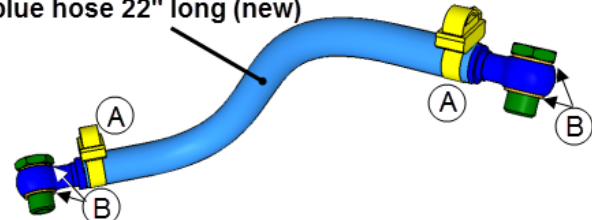

FIGURE 70

b) Use the banjo fittings **recovered** from the previous installation.

hose clamp torque: 30 lbf-in

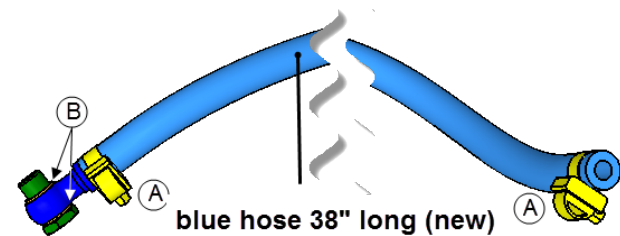

FIGURE 71

61. Install the 22" long and 38" long hoses prepared at the previous step as shown on the images.

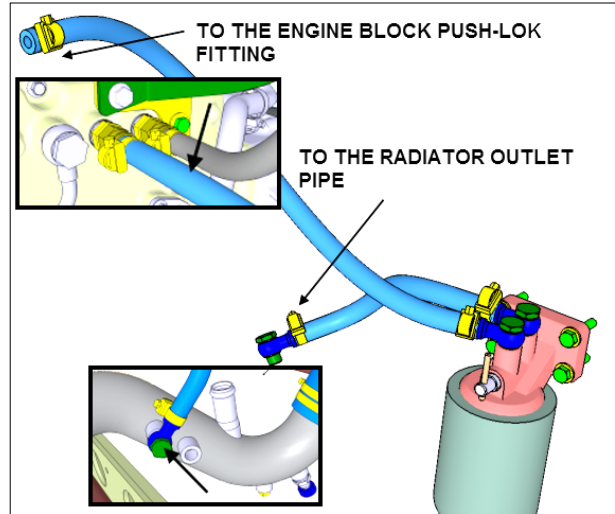

FIGURE 72

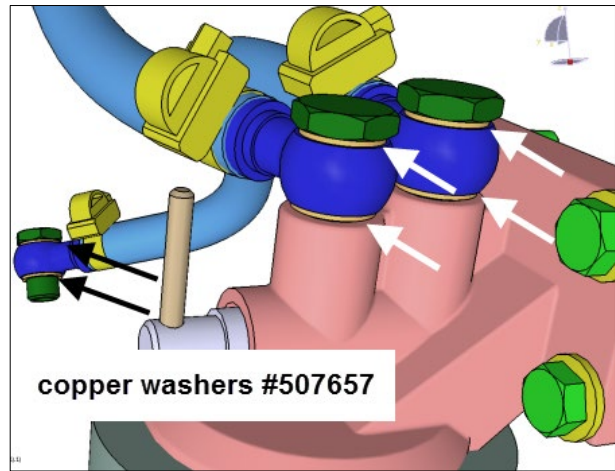

FIGURE 73

62. Connect the DEF injector coolant line return hose to the radiator outlet pipe.

Use two (2) new banjo fitting copper washer #507657

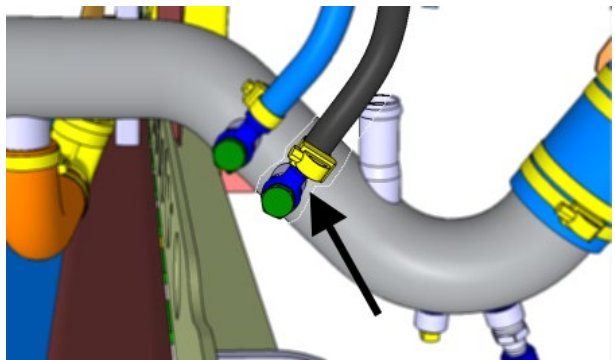

FIGURE 74: DEF INJECTOR COOLANT LINE RETURN HOSE

63. Connect the coolant line that comes from the surge tank to the radiator outlet pipe.

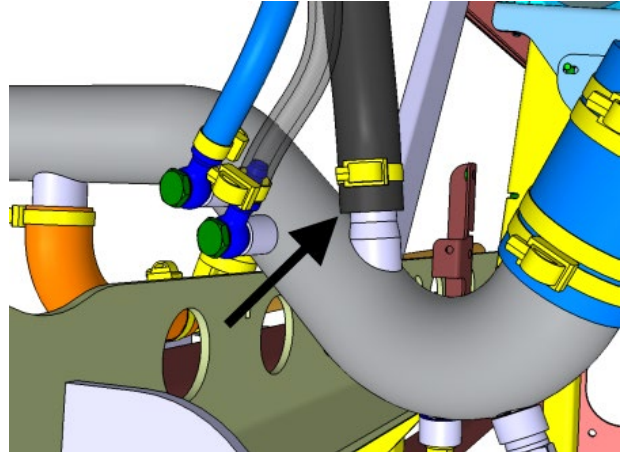
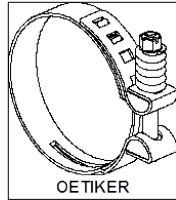
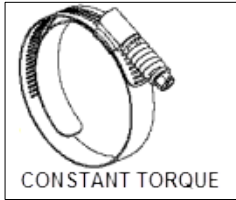

FIGURE 75

TORQUES:

Constant-Torque with spring washers clamps : 90-100 lbf-in

Oetiker clamps – green spring : 12-18 lbf-in

Oetiker clamps – unpainted spring : 8-9 lbf-in

Caillau clamps : 30 lbf-in

64. Secure the coolant hoses together using nylon ties.

A : nylon tie (handcuff type) #N37749 (about 3 to 6, as required)

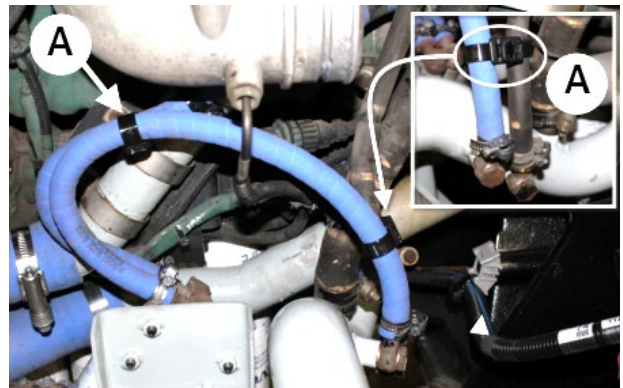

FIGURE 76

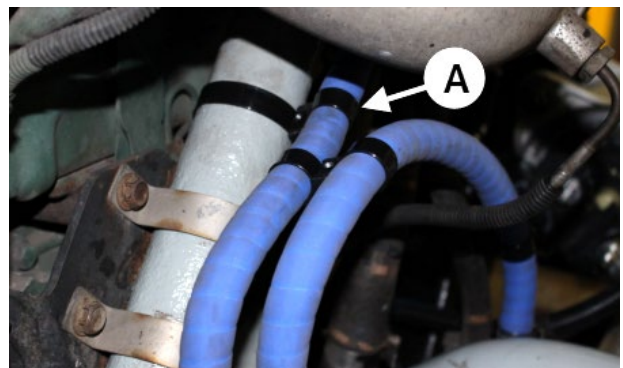

FIGURE 77

65. Secure the coolant hose near the engine block «push-lok» fitting as shown.

B : nylon tie #504016 (1x)

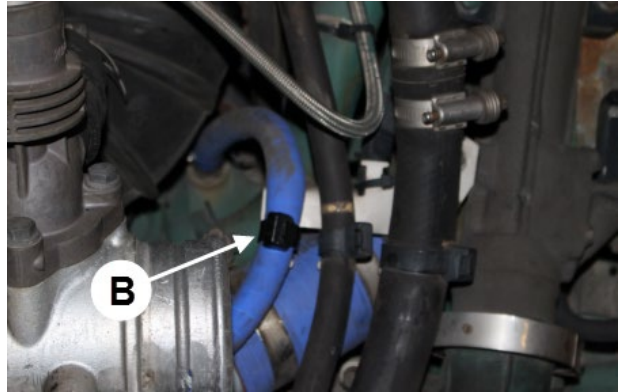

FIGURE 78

66. Hook up the “L.H. alternator power cable” #23498785 to the alternator (+) terminal which is the stud adapter.

A: nut M8 #5001983 torque: 11 lbf-ft

B: flat washer #5001341

C: nylon tie #504016 (2x)

D: tie mount #504013 (2x)

E: rivet #504379 (2x)(hole diameter: Ø 13/64)

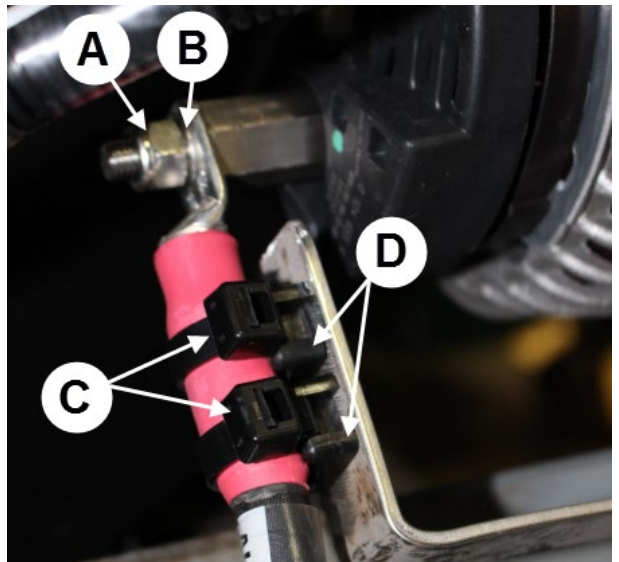

FIGURE 79

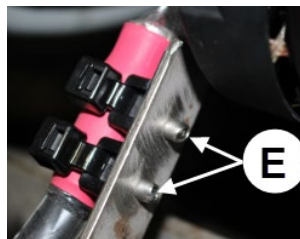

FIGURE 80

67. Connect the “fan drive ground cable” #069246 to the ground stud previously welded to the chassis.

A: split lock washer #500482

B: brass nut #500998

C: fan drive ground cable #069246

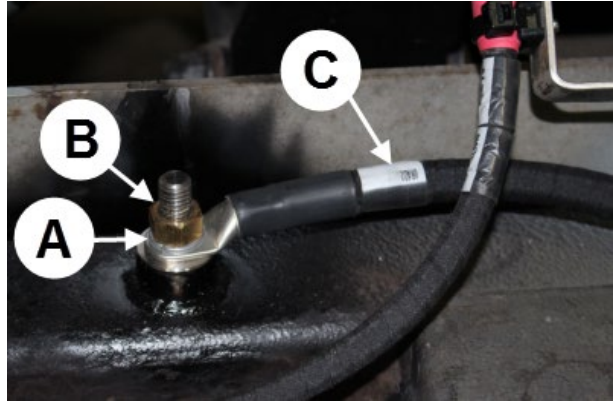

FIGURE 81

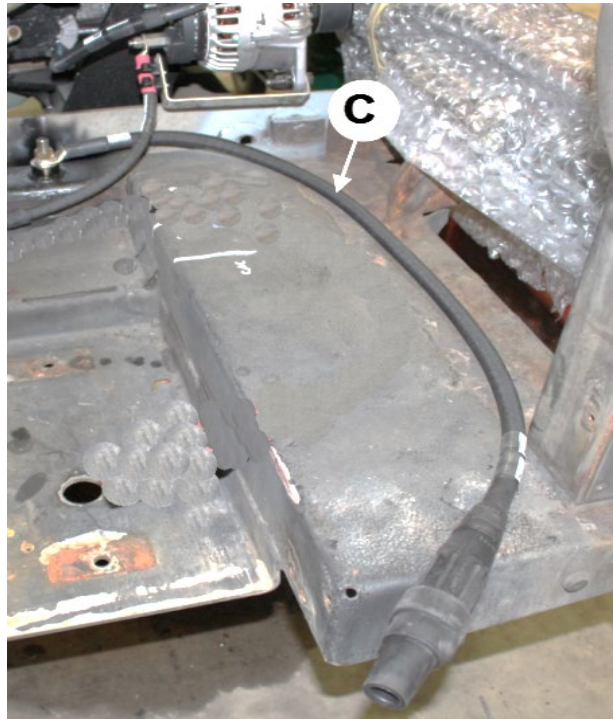

FIGURE 82

68. Apply Color Guard rubber coating on the ground stud connection.



FIGURE 83: GROUND STUD WITH RUBBER COATING

69. Apply Color Guard rubber coating at the alternator ground (\perp) and positive (+) connections.

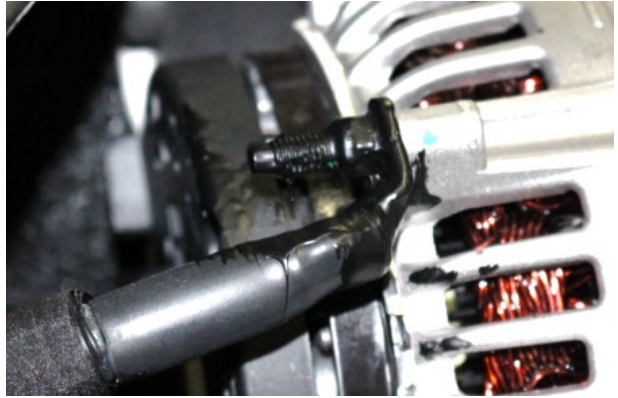

FIGURE 84: GROUND CONNECTION ON THE ALTERNATOR



FIGURE 85: POSITIVE (+) CONNECTION ON THE ALTERNATOR

70. Install a tie mount #509490 at the location shown on the picture. Secure the tie mount with a rivet.

A: tie mount #509490

B: rivet #504610 (hole diameter: Ø 17/64)

C: nylon tie #509491

D: fan drive power cable #23498721

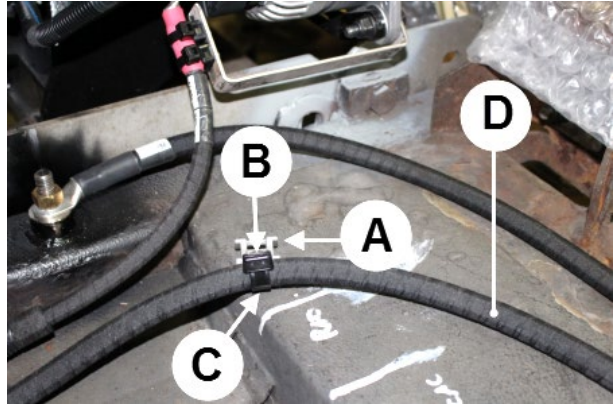

FIGURE 86

71. Secure the “fan drive power cable” #23498721 onto the tie mount using a nylon tie. Make sure to leave **26 inches long** from the tie mount up to the end of the “fan drive power cable” red connector.



FIGURE 87



FIGURE 88



FIGURE 89

72. Install **six (6) tie mounts** to secure the “fan drive power cable” and the “L.H. alternator power cable” as shown on the picture.

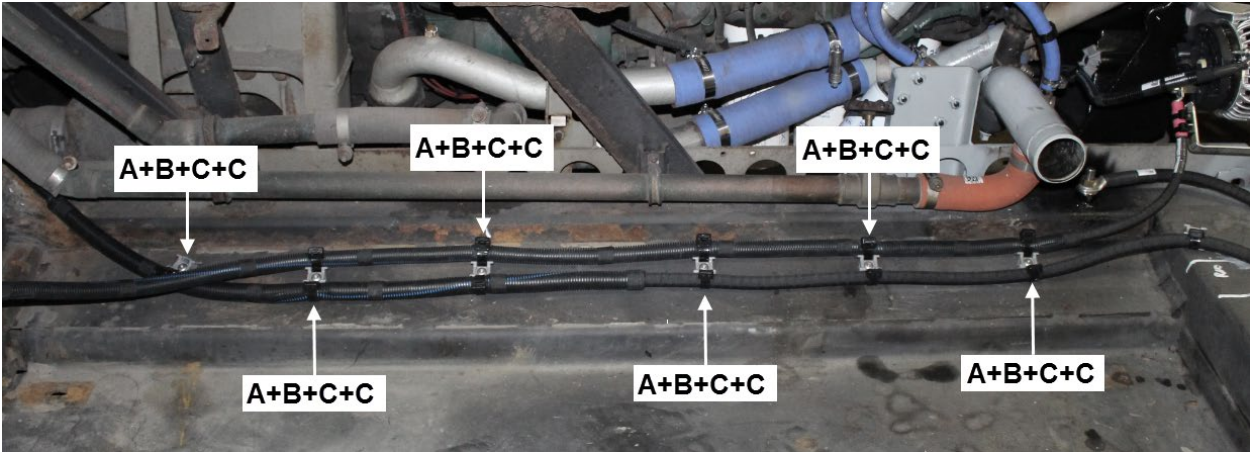

FIGURE 90

A: tie mount #509490

B: rivet #504610 (hole diameter: Ø 17/64)

C: nylon tie #509491



FIGURE 91

73. Route the “*fan drive power cable*” and the “*L.H. alternator power cable*” up to the main power compartment. Refer to the pictures at right as a guide for the installation.

74. Secure both cables using **five (5) tie mounts #509490** fixed with **five (5) rivets #504610** (hole diameter: Ø 17/64). Secure the cables on the tie mounts as previously done with **ten (10) nylon ties # 509491**.

A: tie mount #509490

B: rivet #504610 (hole diameter: Ø 17/64)

C: nylon tie #509491

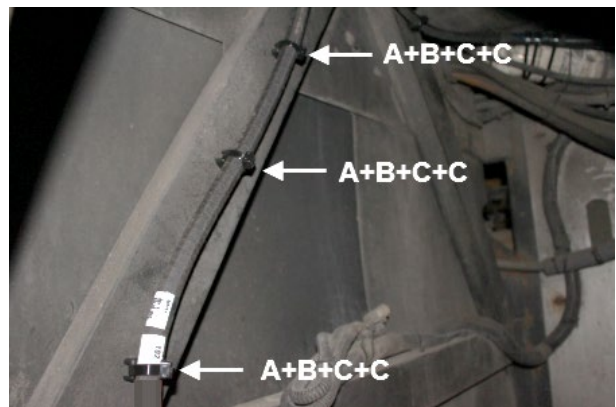

FIGURE 92

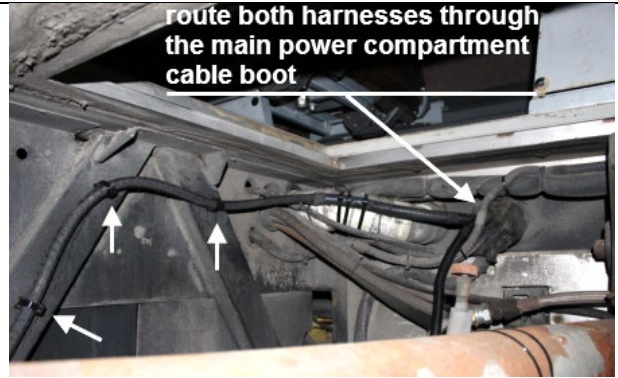

FIGURE 93

75. INSTALLATION OF THE "FAN TO RJB INTERFACE" HARNESS #23488790

- a) Route the "fan to RJB interface" harness #23488790 up to the main power compartment. Secure this harness to the fan drive power cable using nylon ties #504016.
- b) This harness will be connected close to the fan drive power cable, thus it also requires 26 inches of free length.

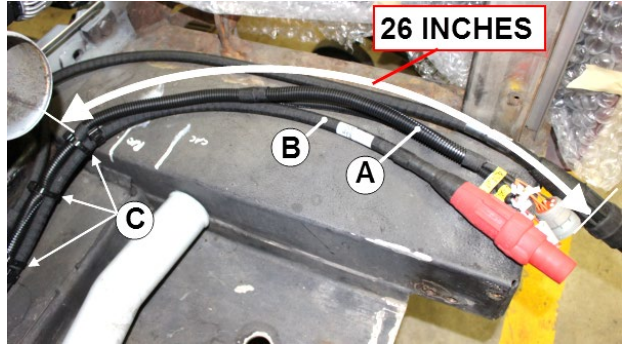

FIGURE 94

A: FAN TO RJB INTERFACE" HARNESS #23488790

B: FAN DRIVE POWER CABLE

C: NYLON TIES #504016 (23x approx.)

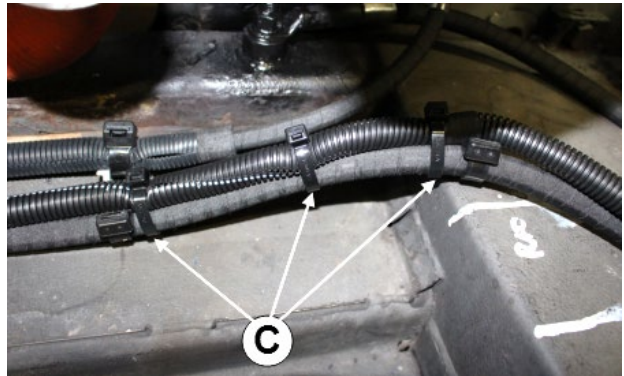

FIGURE 95

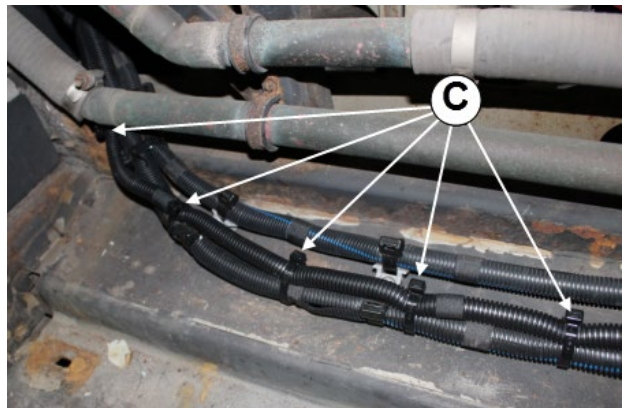

FIGURE 96

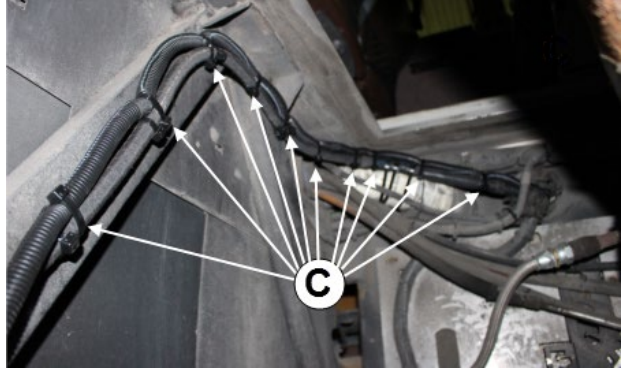

FIGURE 97

76. INSTALLATION OF THE ALTERNATOR CONTROL HARNESS #069511

- a) Connect the harness #069511 to the alternator.
- b) Secure the harness with nylon ties as shown on the pictures.

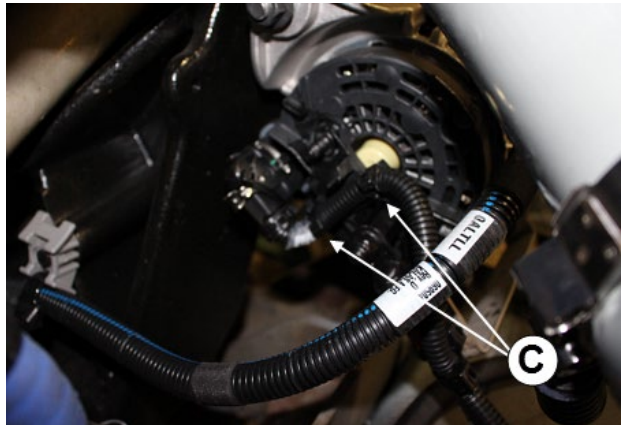

FIGURE 98: C: NYLON TIES #504016 (2x)

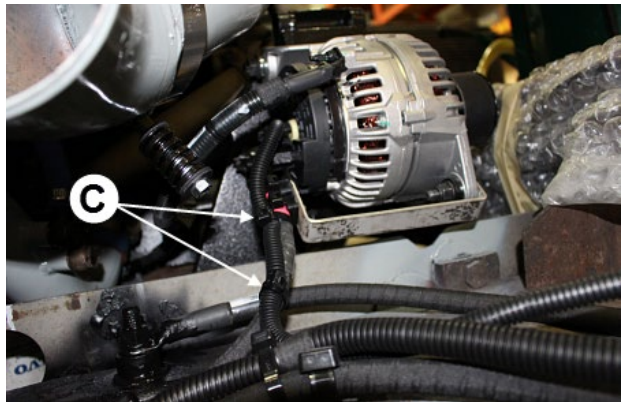

FIGURE 99: C: NYLON TIES #504016 (2x)

77. Connect the new CAC outlet pipe #050406 to the engine intake elbow. **NOTE: in case of interference between this pipe and the ping tank, rotate the ping tank.**

A: #030096 hose (1x)

B: #21490630 spring loaded clamp (2X)

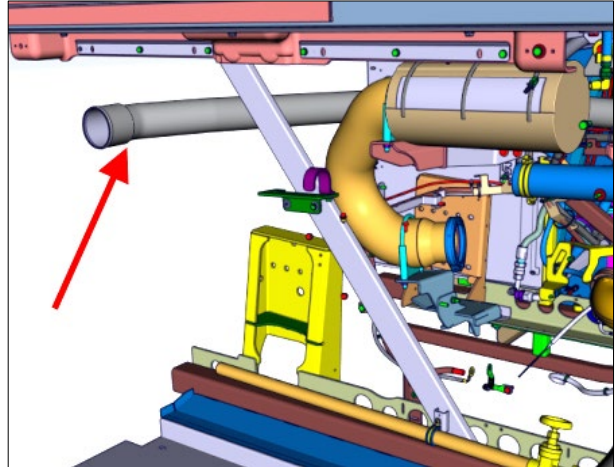

FIGURE 100

Constant Torque hose clamps 4.25in - charge air cooler (CAC) 4.5-5.5 lbf-ft

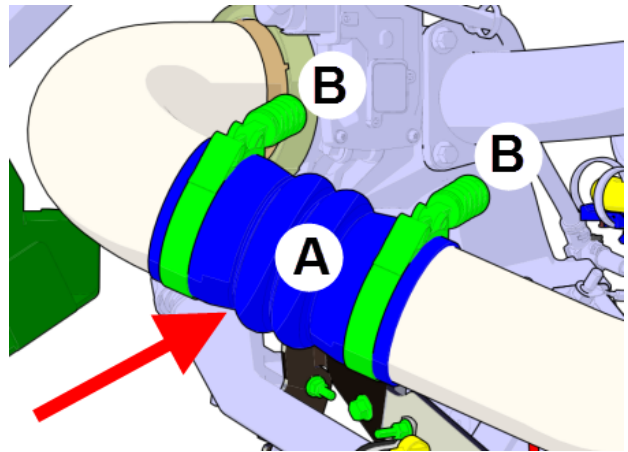

FIGURE 101: CONNECTION AT THE ENGINE INTAKE ELBOW

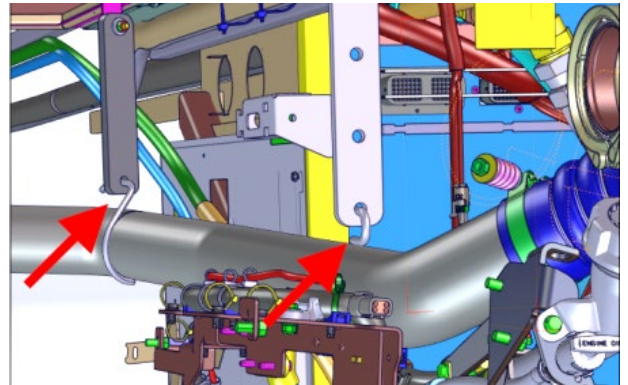

FIGURE 102

78. If your vehicle is equipped with AFSS (Automatic Fire Suppression System), the new CAC outlet pipe #050406 is likely to come into interference with a AFSS extinguishing agent hose (see image) near the end of the pipe that connects with the Charge Air Cooler.

If this is the case, move the hose the other side of the bracket shown, to prevent rubbing between the hose and the CAC outlet pipe.

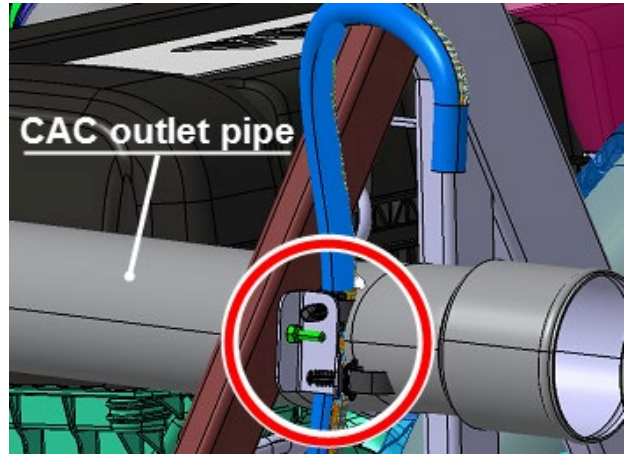

FIGURE 103

79. On the diagonal member, change the existing radiator inlet pipe bracket for the new bracket #050305. Use the existing hardware.

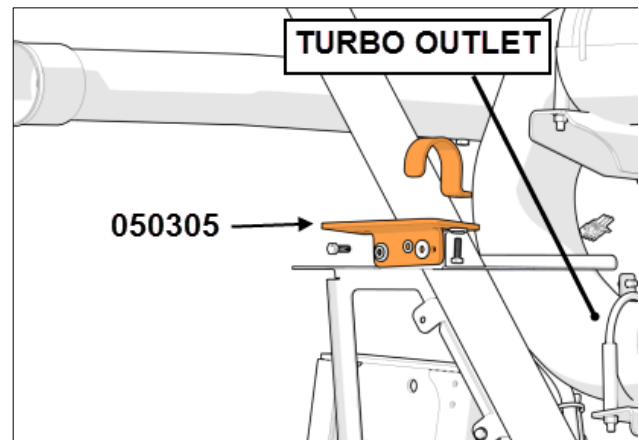

FIGURE 104

80. Install the new radiator inlet pipe #050414.

A: #052889 silicone hose

B: # 992089 hose clamp (4x); torque: 30 lbf-in

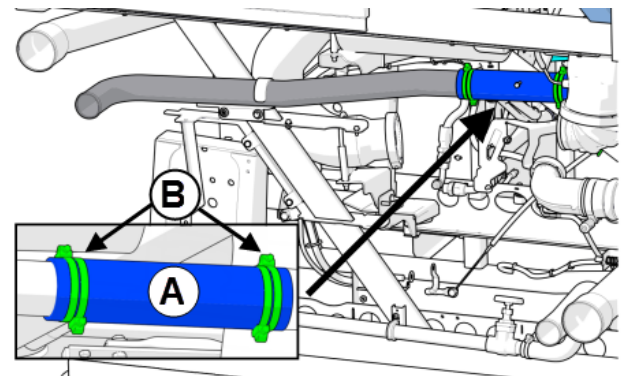

FIGURE 105

81. Install the new **CAC inlet pipe #050286**. Use one new #030096 CAC **flexible hose**. Secure the hose using two (2) spring loaded clamps #21490630.

A: #030096 hose

B: #21490630 spring loaded clamp (2X), torque: 5 lbf-ft

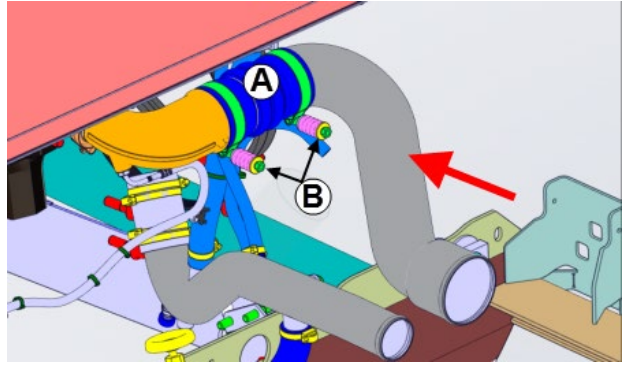

FIGURE 106: CONNECTION AT THE TURBO OUTLET ELBOW

82. Reinstall the cooling pack.

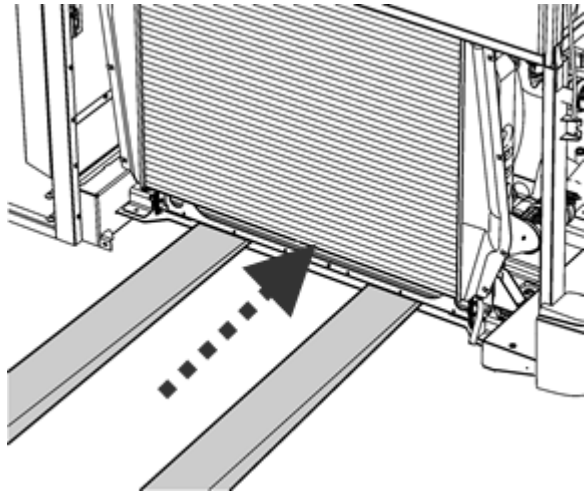

FIGURE 107

83. Place the cooling pack supports over the new holes that were previously made.

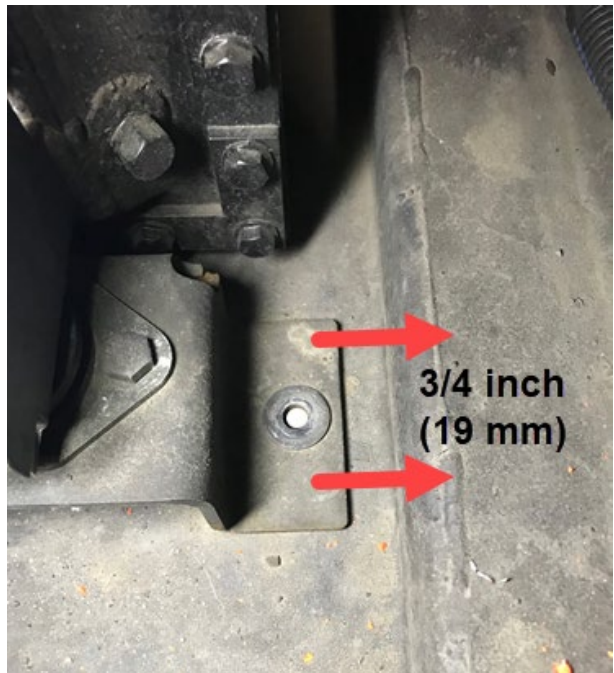

FIGURE 108

84. Secure the cooling pack base with the following parts:

A: 4x screw #502804

B: 8x washer #5001751

C: 4x nut #502859

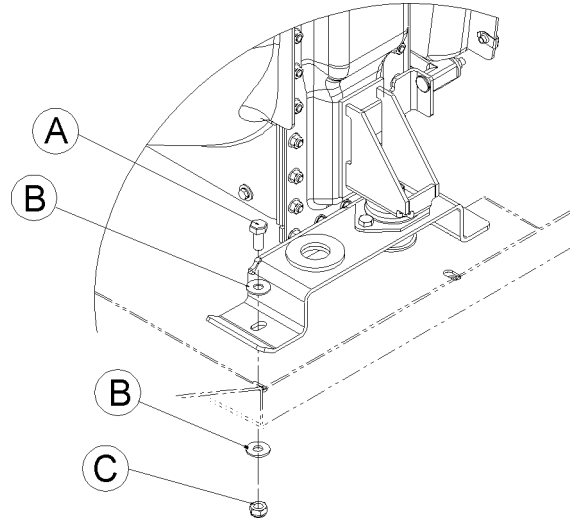

FIGURE 109

85. In case of interference between the charge air cooler and the DPF intake pipe, loosen the pipe's V-band clamps. Move the pipe in order to increase the clearance, then hold the pipe in place and tighten the V-band clamps.

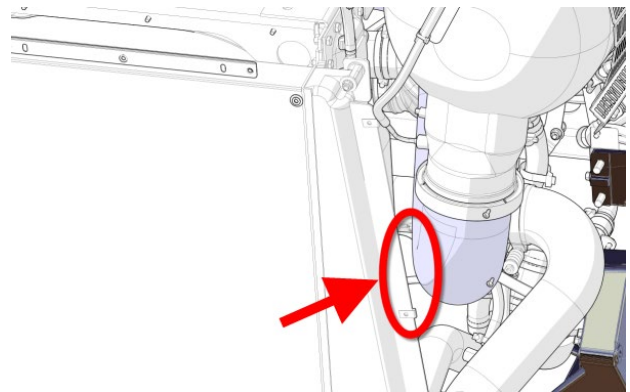

FIGURE 110

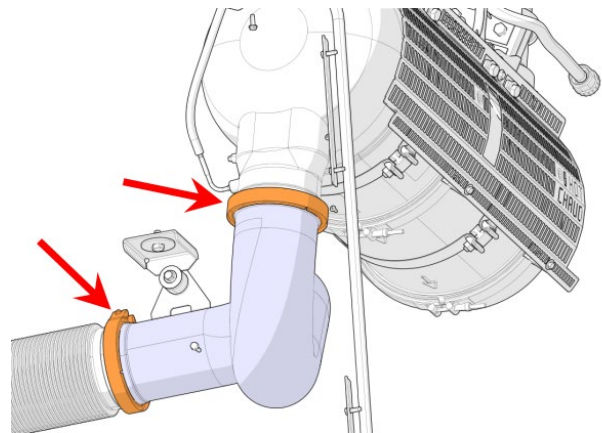

FIGURE 111

86. Using parts #501332, #501308, #501329, #501027, mount the brass fitting assembly shown on the image at right.

Apply Loctite 567 Thread Sealant on the threads

A: #501027

B: #501329

C: #501308

D: #501332

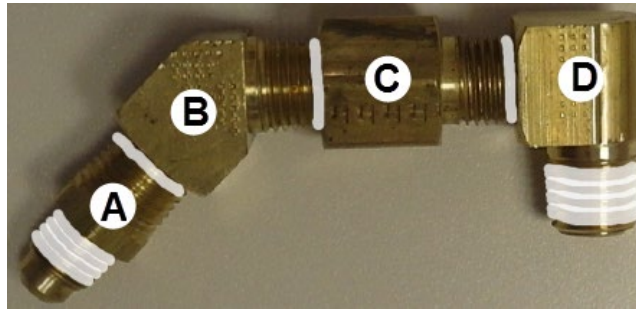

FIGURE 112: BRASS FITTING ASSEMBLY

87. Remove the vent hose fitting found on the radiator.

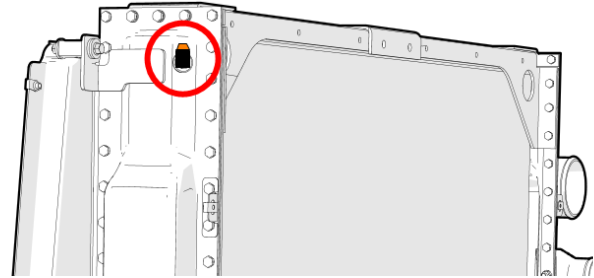

FIGURE 113

88. Install the brass fitting assembly in place of the former vent hose fitting and then connect the **radiator vent hose**.



89. Prepare the **cooling pack upper attachment** with the three (3) rectangular plates (see image) recovered from the former installation and the following parts:

A: anti-vibration mount #21185073

B: upper radiator support #050214

C: 2x screw #5001738 , 2x nut #502837

D: 2x screw #5001738 , 2x washer #500942

E: 2x screw #5001745 , 2x washer #500942

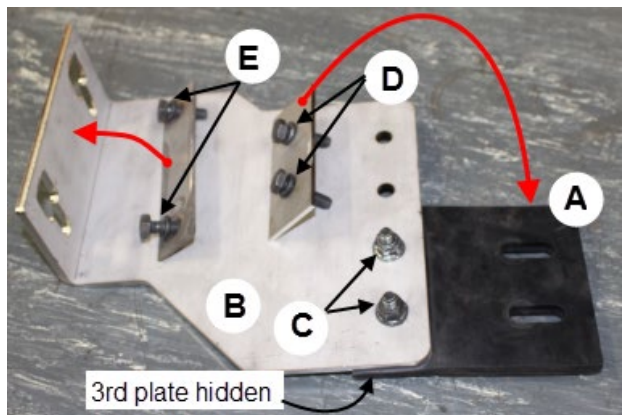

FIGURE 114

One end of the upper attachment is mounted on the radiator frame (image at right)

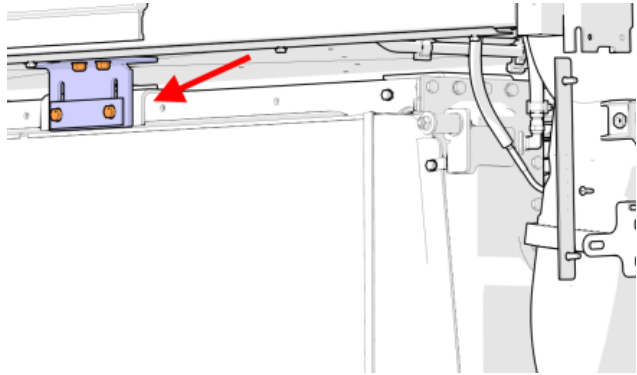

FIGURE 115

Bolt the anti-vibration mount onto the vehicle chassis

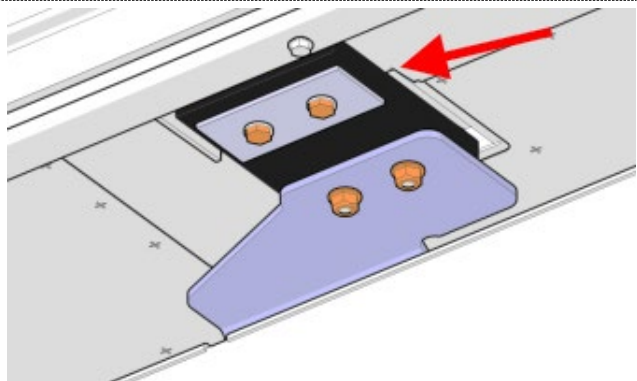

FIGURE 116

90. Reinstall all the blue flexible hoses at the CAC and radiator (at the lower connections of the cooling pack). Install with the following parts:

A: #21490616 clamp (4x)

B: #531471 flexible hose

C: #053617 silicone hose

D: #992089 (4x)

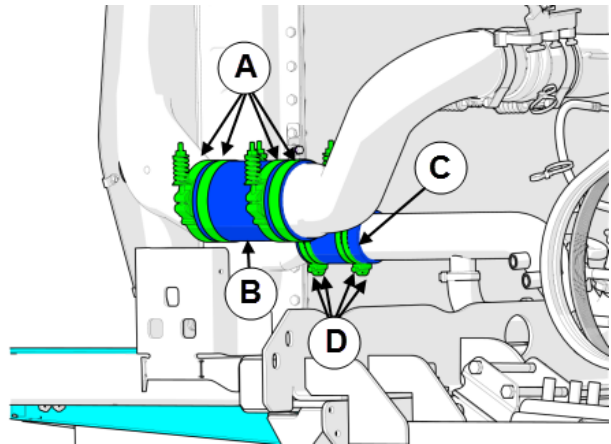

FIGURE 117

91. Reinstall all the blue flexible hoses at the CAC and radiator (at the upper connections of the cooling pack). Use the following parts::

A: 1x flex hose #531469

B: 1x silicone hose #053617

C: 4x clamp #21490616

D: 4x clamp #992089

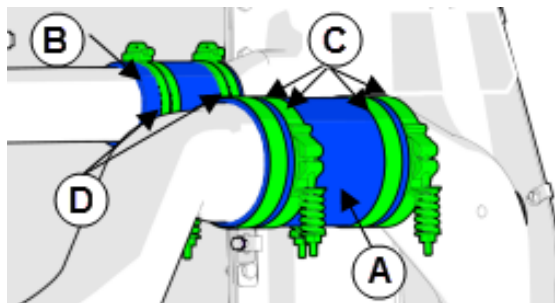

FIGURE 118

For proper clamp torque, refer to HOSE CLAMP TORQUE on page 12

92. Reinstall the lower cooling pack protector tube with the following hardware:

4x Screw #502804

4x split lock washer #5001737

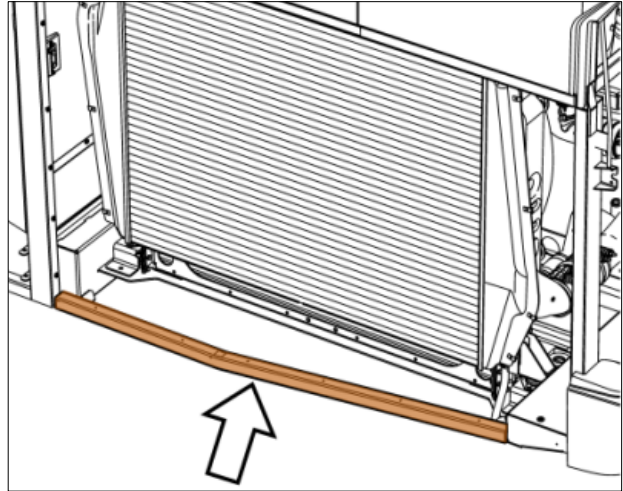

FIGURE 119

93. Install the sealing element #050200. Screw it on the existing threaded holes on the upper part of the radiator. Secure with the following hardware:

6x bolt #5001697

6x lock washer #502570

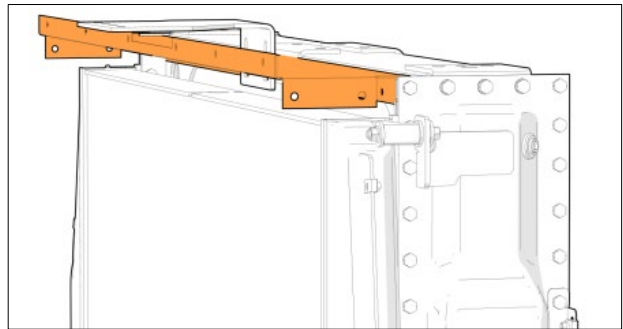

FIGURE 120

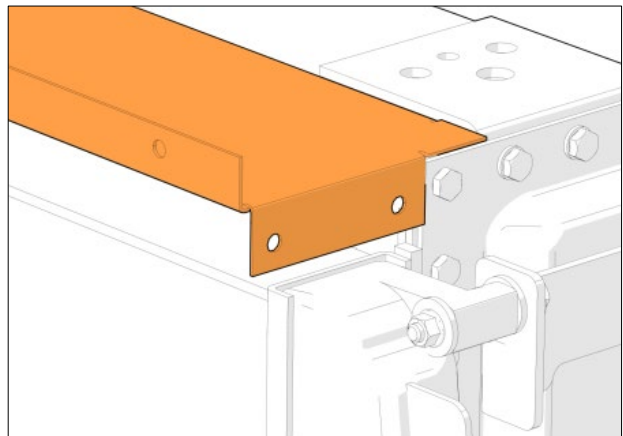

FIGURE 121

94. Install the sealing element #050203. Screw it on the existing threaded holes on the bottom of the radiator. Secure with the following hardware:

6x bolt #5001697

6x lock washer #502570

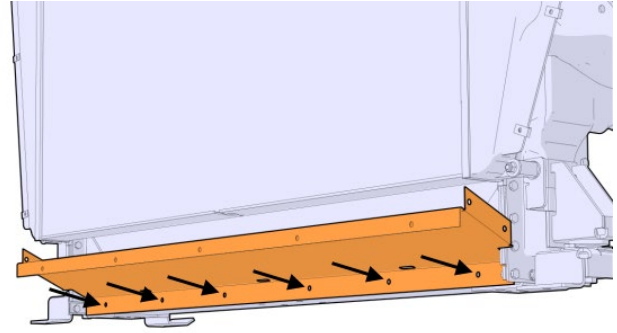

FIGURE 122

95. Prepare the sealing elements #050201 and #050202. On both parts, apply foam tape #506040 on the edges as shown on the image.

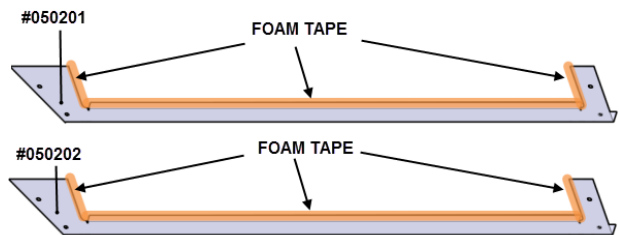

FIGURE 123

96. Install the sealing elements #050201 and #050202. Screw them onto the upper and lower sealing elements installed at the previous steps. Secure with the following hardware:

8x bolt #5001697

8x lock washer #502570

A: #050201

B: #050202

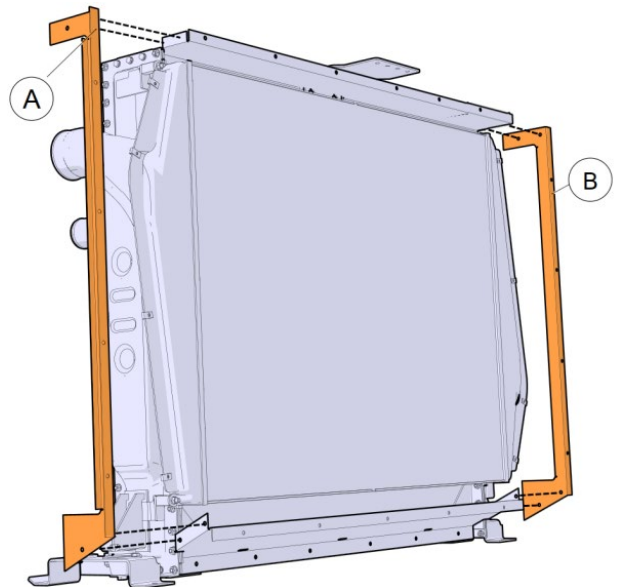

FIGURE 124

97. Cut two pieces of 39 inches (990 mm) long of **rubber extrusion #506025**.
98. Using good industrial glue (Loctite 404 or similar product), glue the two pieces of rubber extrusion centered on the reinforcement angles of fan support panel **#050195**.



FIGURE 125

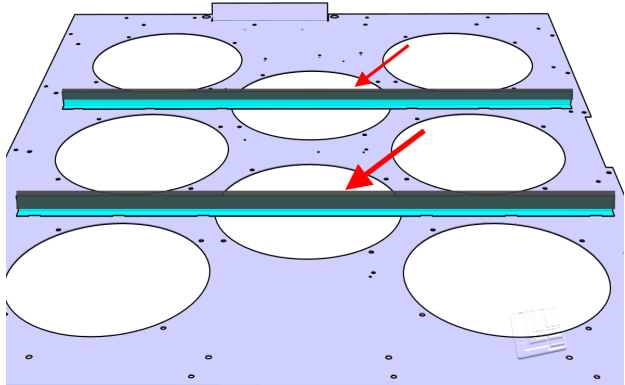

FIGURE 126

99. Install panel **#050195**. Secure with the following hardware:
19x bolt #5001697
19x lock washer #502570

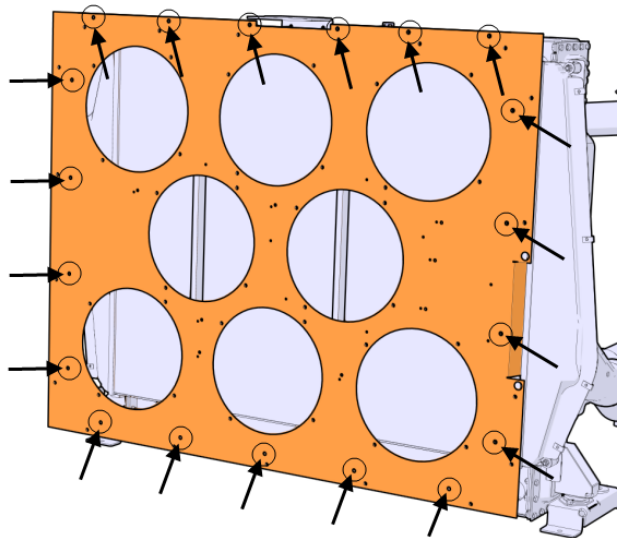

FIGURE 127

100. Install the upper left #050204 and upper right #050206 sealing elements.

Secure with the following hardware:

6x bolt #5001697

6x lock washer #502570

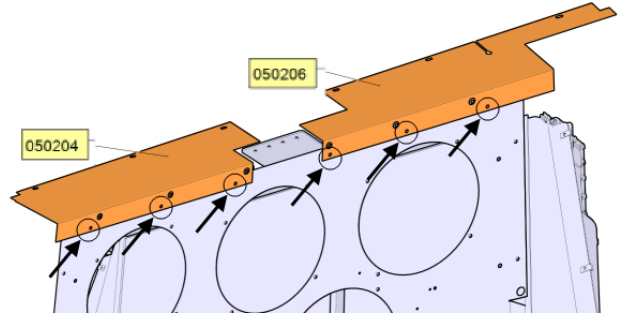

FIGURE 128

101. Install the lower sealing element #050213.

Secure with the following hardware:

5x bolt #5001697

5x lock washer #502570

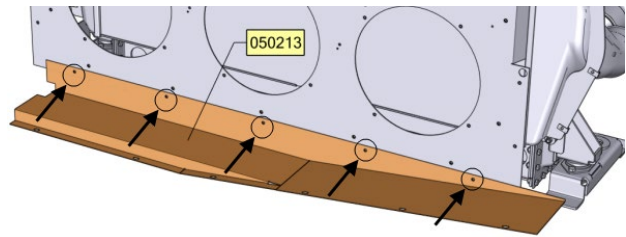

FIGURE 129

102. Install the L.H. side sealing element #050208.

Secure with the following hardware:

4 bolts #5001697

4 lock washers #502570

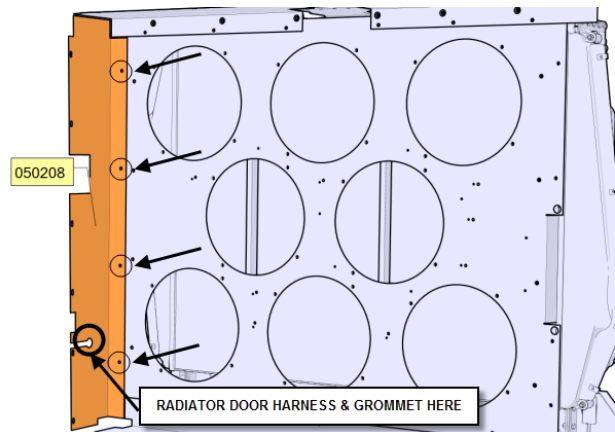

FIGURE 130

103. Install the R.H. side sealing element #050255.

Secure with the following hardware:

4x bolt #5001697

4x lock washer #502570

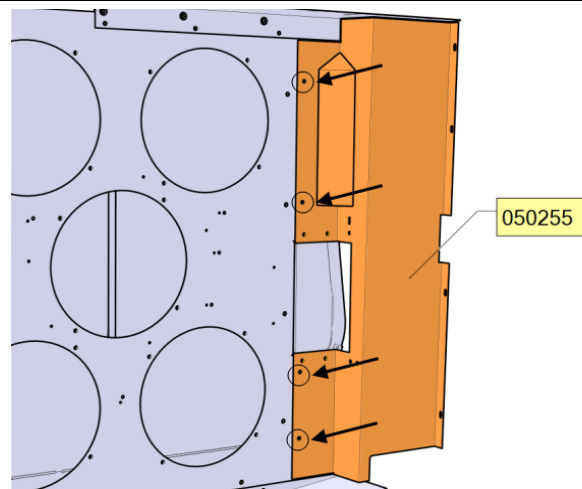

FIGURE 131

104. Install the **fans** and **fan hand guards** on the panel in the same arrangement shown on the image. **Be sure to place the fan so that the cable is at the proper location, 3 O'clock, 6 O'clock or 12 O'clock.** Refer to the image at right.



FAN HAND GUARD

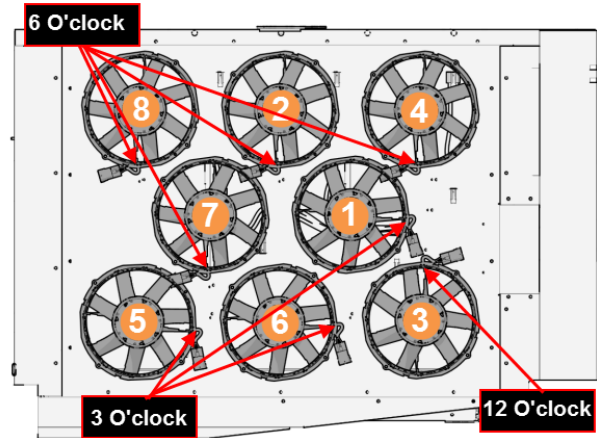

FIGURE 132

Install with the following hardware:

32x bolts #502686

32x lock washers #5001833

Prescribed torque:30 lbf-in

105. Take note that each harness is labeled with a number corresponding to an appropriate fan location.



106. Snap the fan blue connector in the holes punched on the panel for that matter.

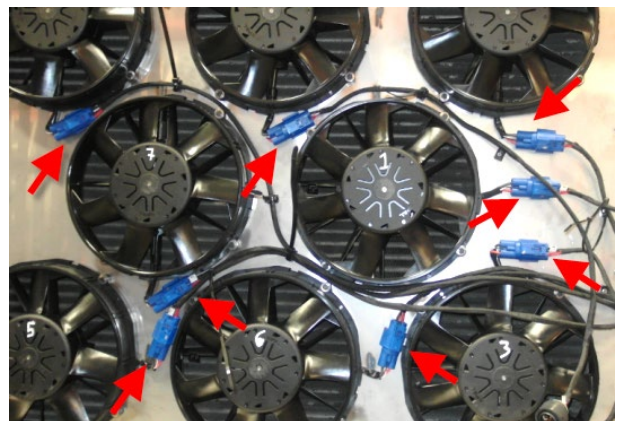

FIGURE 133

107. Route and secure the fan cables as shown on the images.

Secure with the following parts:

A= nylon tie mount #504013 + rivet #504379 + nylon tie #504016

B= nylon tie #504016

Do not tighten the nylon ties at this moment

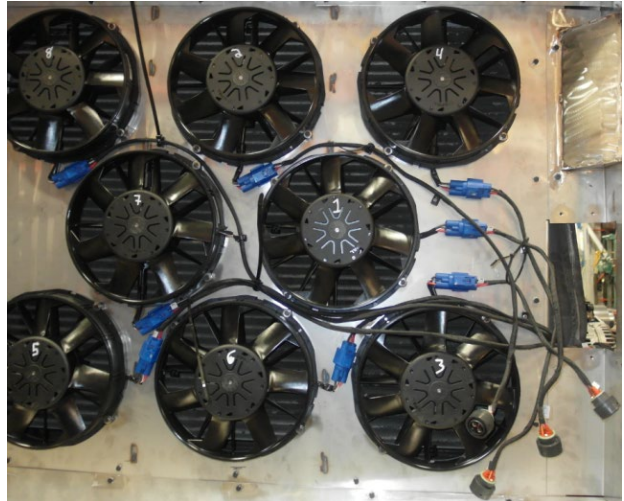

FIGURE 134

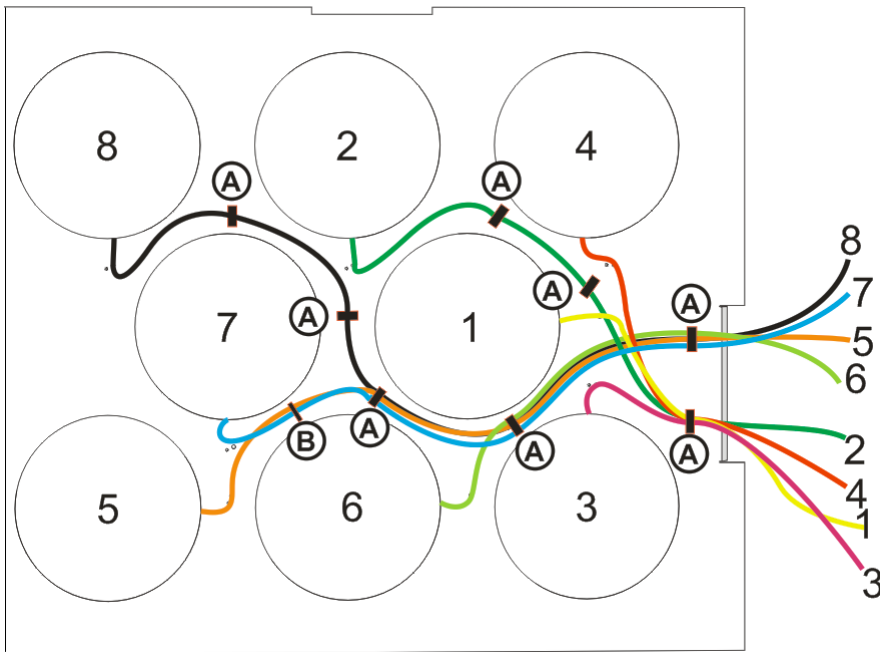

FIGURE 135

108. Install the circuit breaker box #564512.

Install with the following hardware:

4x bolt #500119

4x lock washer #5001868

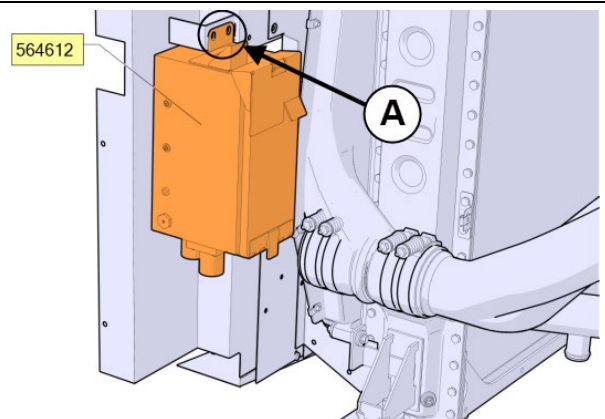

FIGURE 136

A: 2x bolt #500119 + 2x lock washer #5001868

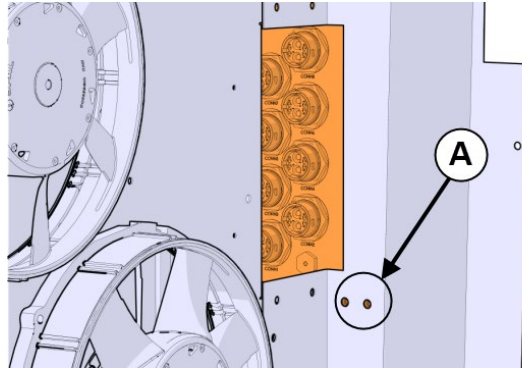

FIGURE 137

A: 2x bolt #500119 + 2x lock washer #5001868

109. Connect each fan to the corresponding connection port on the circuit breaker box.

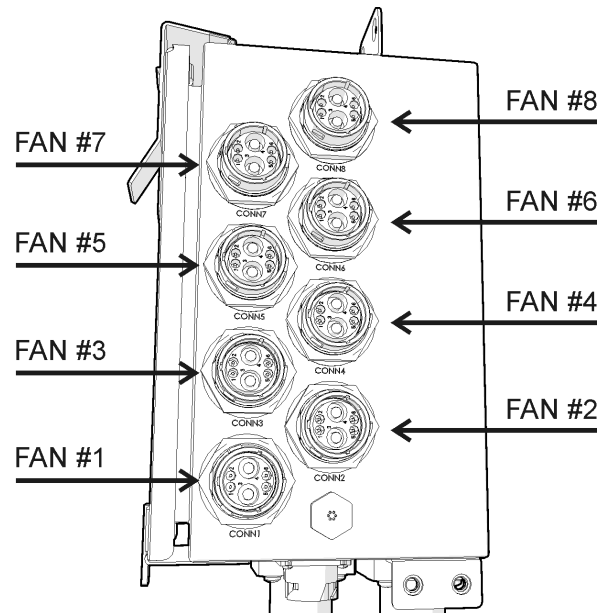

FIGURE 138

110. Tighten the nylon ties previously installed while routing the fan cables.
111. Use two (2) additional **nylon ties #504016** to secure the extra-length of cables together close to the circuit breaker box as shown on the image at right.

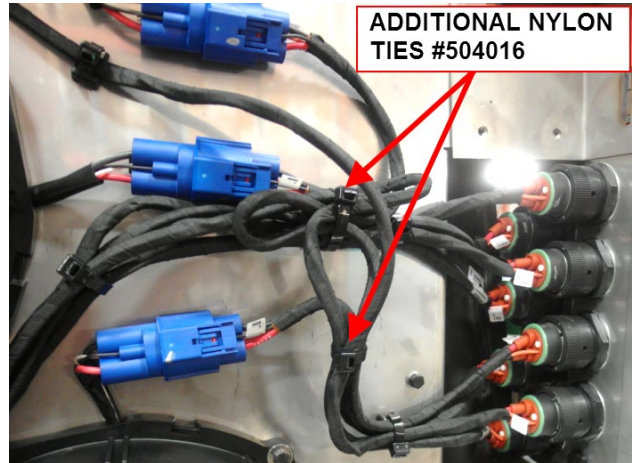

FIGURE 139

112. Install the electrical **connector cover #050229**.

Fasten with the following hardware:

4x bolt #5001697

4x lock washer #502570

113. Using good industrial glue (Loctite 404 or similar product), glue three (3) pieces of rubber extrusion #506025 as shown on the connector cover.

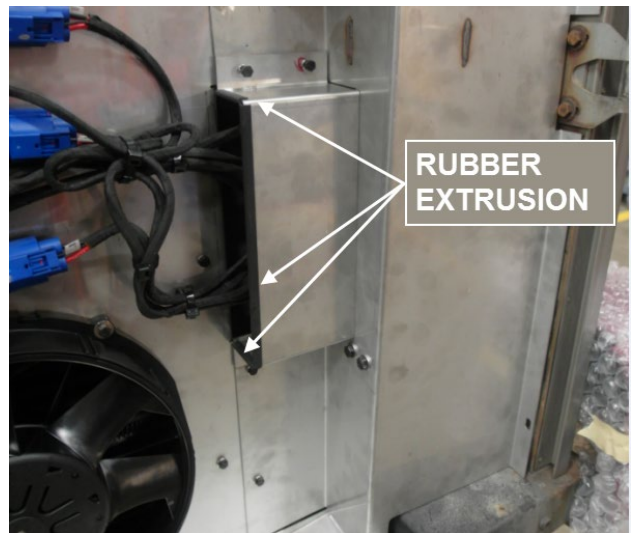

FIGURE 140



FIGURE 141

114. Complete the installation of the sealing elements. Screw the panels to the chassis threaded holes where shown on the image. Use the following hardware:

22x bolt #502848

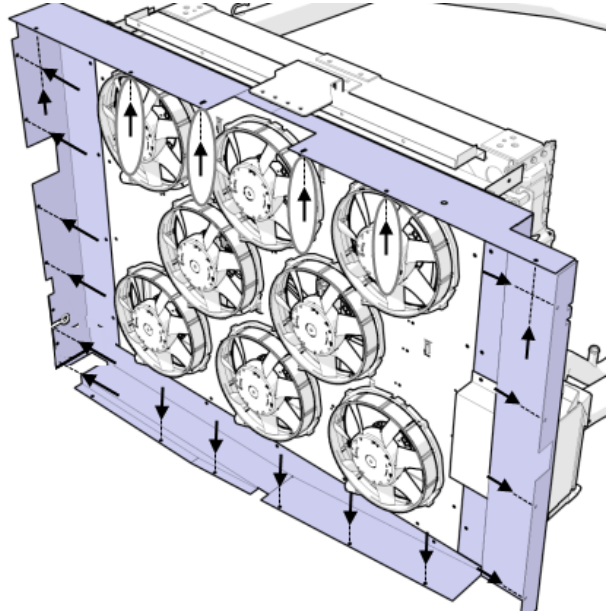

FIGURE 142

115. Complete the connection to the fan circuit breaker box (three connectors: gray, black and red).

A: fan drive ground cable (black connector)

B: fan drive power cable (red connector)

C: "fan to RJB interface" harness (gray connector)

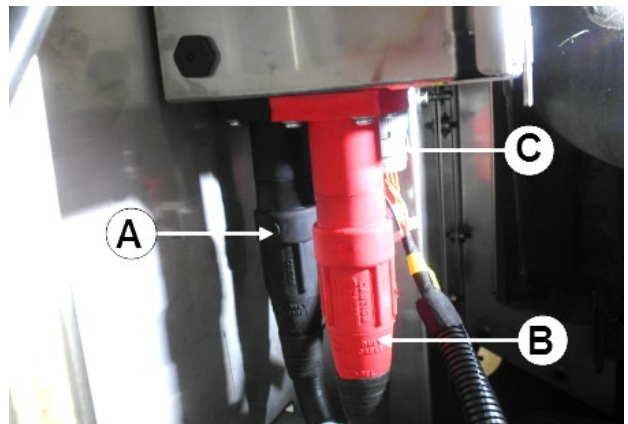

FIGURE 143

116. Secure the fan drive ground cable and the fan drive power cable connected to the fan drive circuit breakers box as shown on the pictures.

A: rivet #504379 (6x) (hole diameter: \varnothing 13/64)

B: tie mount #504013 (6x)

C: nylon tie #504016 (6x)

D: handcuff nylon tie #N37749 (1x)

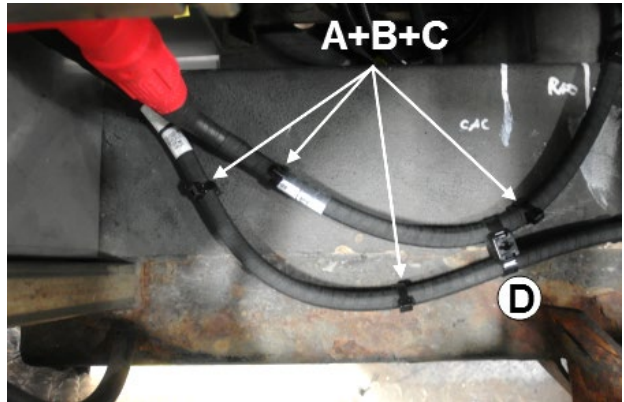

FIGURE 144

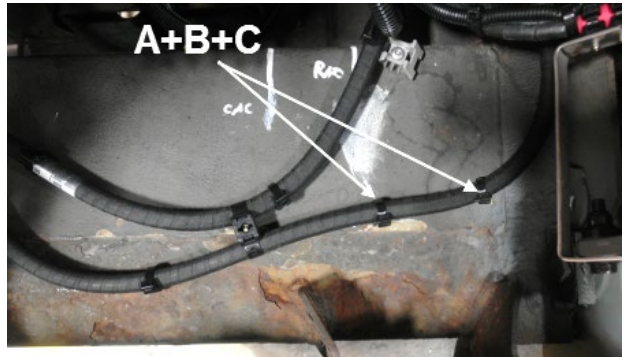

FIGURE 145

117. Connect the alternator control harness connector **C-ALT3** to connector **C-ALT3** of the "fan to RJB interface" harness. Secure the extra length of harness as shown with nylon ties.

A: handcuff nylon tie #N37749 (3x)

B: nylon tie #504016 (4x)

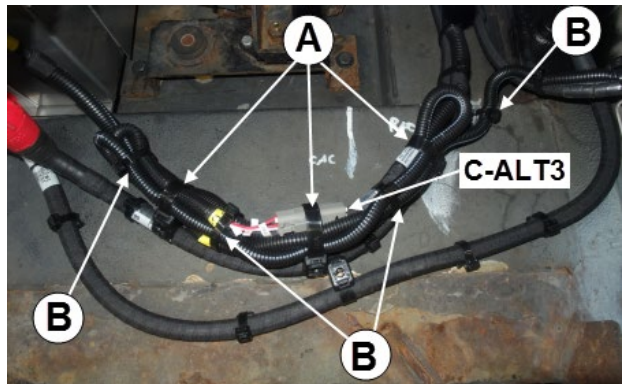

FIGURE 146



FIGURE 147

INSTALLATION OF ELECTRIC COMPONENTS AND HARNESS CONNECTIONS IN THE MAIN POWER COMPARTMENT

DIAGRAM OF ELECTRICAL CONNECTIONS

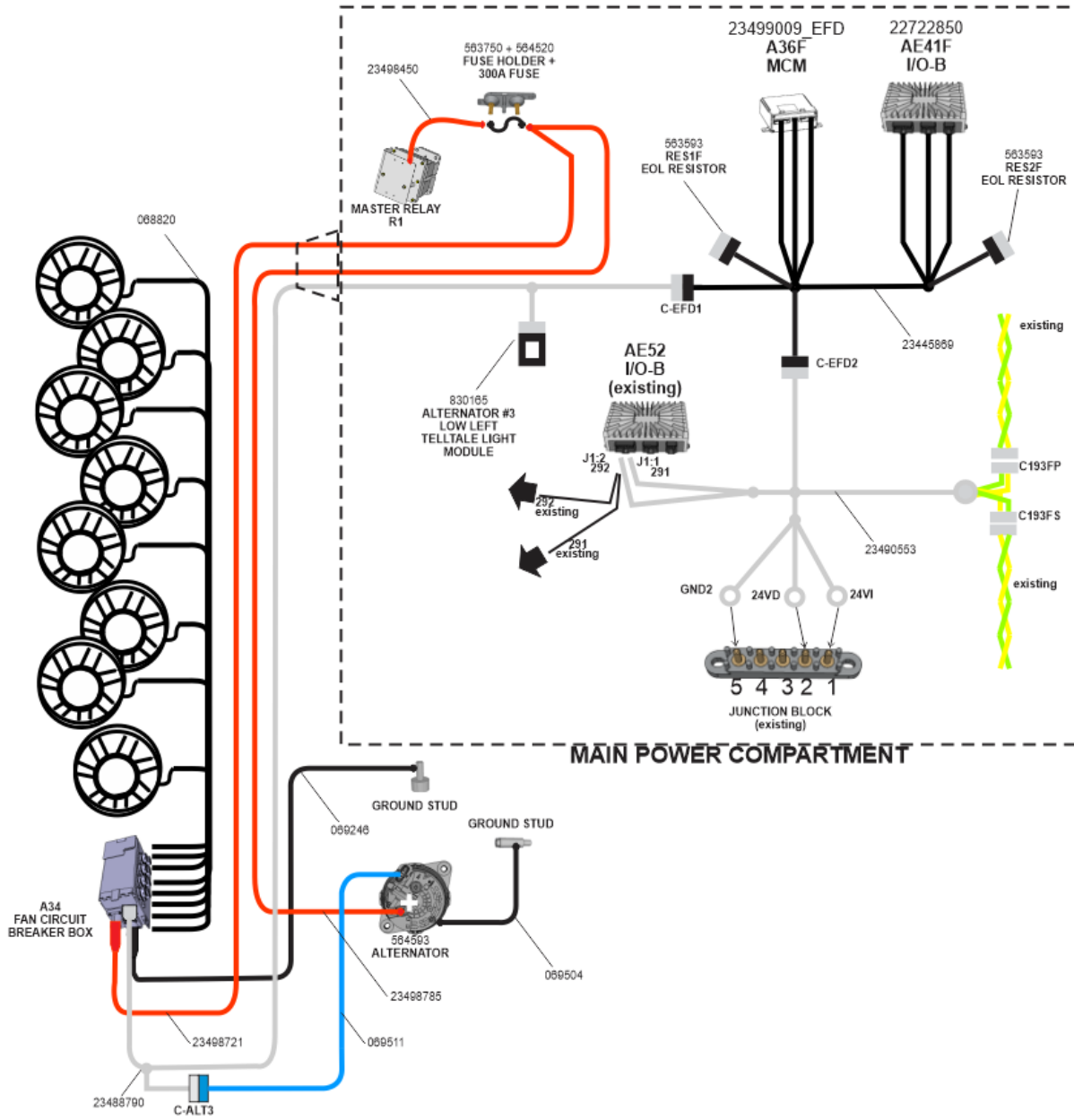

118. In the battery compartment, disconnect the battery ground cable from the chassis ground stud.

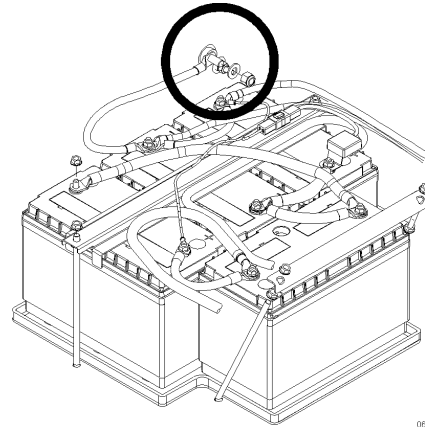

06856

FIGURE 148

119. Most of the electric components will be installed on the bulkhead at the right of **master relay R1** (when facing it). Locate the master relay R1 (refer to the image at right).

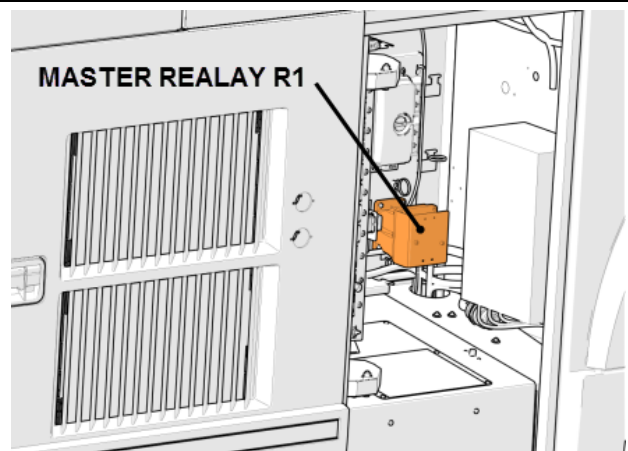

FIGURE 149

120. If the situation applies to the vehicle on which you are working on, remove the two (2) useless studs found on the bulkhead and then smooth the surface.

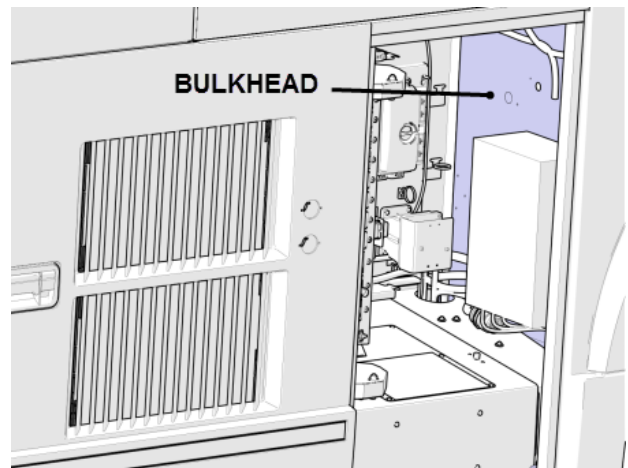

FIGURE 150



FIGURE 151

121. Make sure this is no voltage applied to the master relay R1 posts and then, remove the master relay R1 cover.

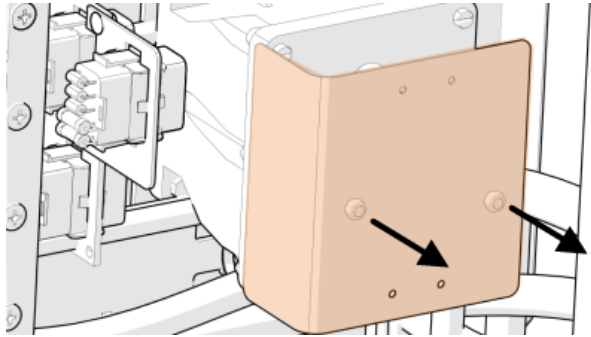

FIGURE 152

122. Disconnect the four (4) cable lugs connected to the master relay R1 upper post.
123. Momentarily, connect the angled lug of the "master relay R1 to 300A fuse" cable **#23498450**.

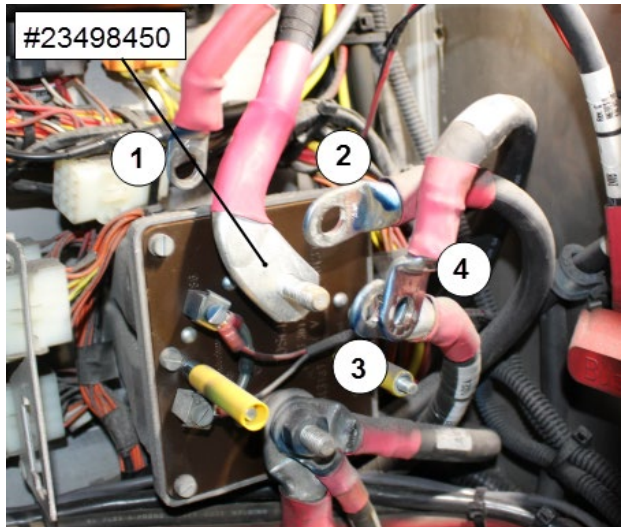

FIGURE 153

124. Find the best location where to install the **fuse holder #563750** on the bulkhead. Take note that the fuse holder must be installed at a distance that allows cable #23498450 to reach it.

125. Drill two 11/64 pilot holes for the installation of the fuse holder on the main power compartment bulkhead. Secure with the following hardware:

A: tapping screw #500658 (2x) + flat washer #5001341 (2x)

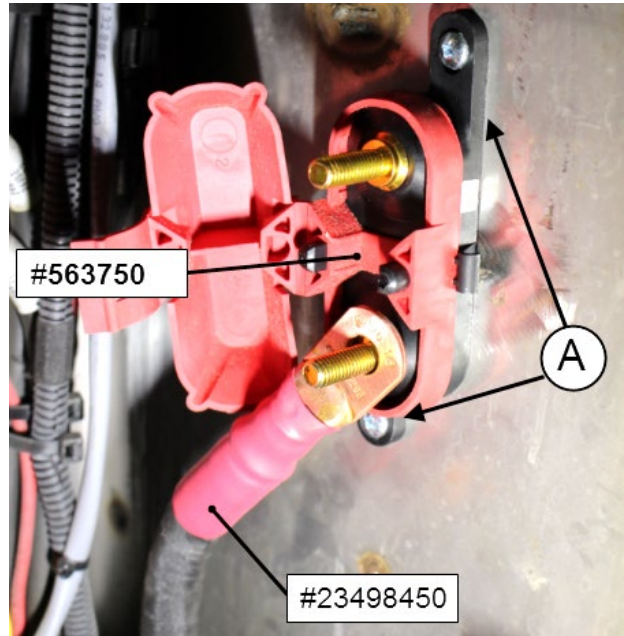

FIGURE 154

126. Reinstall the four (4) other cable lugs to the master relay R1 upper post.

Being the largest lug at R1, the cable #23498450 lug should be placed first on the post (behind all the other lugs) (or second if rubbing is likely to happen).

Master relay R1- Port 30 – M10-1.5 stud nut torque: 160-195 lb-in (18-22 Nm)

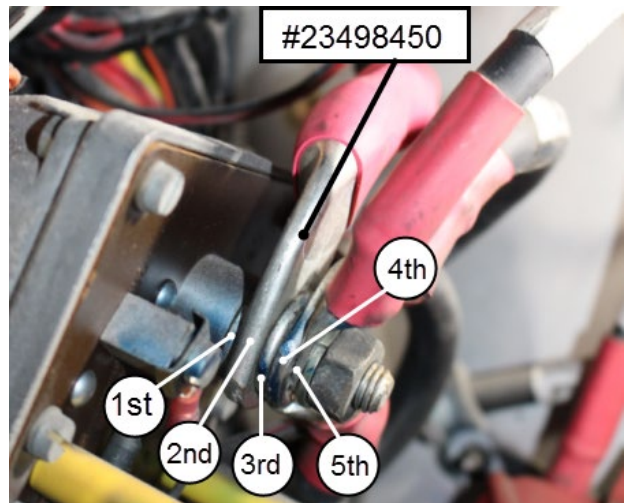

FIGURE 155: ON THIS PICTURE, CABLE #23498450 LUG IS IN SECOND (2ND) POSITION BECAUSE IT WAS LIKELY TO RUB ON THE HEAD OF ONE OF THE FOUR SCREWS.

127. Reinstall the master relay R1 cover.

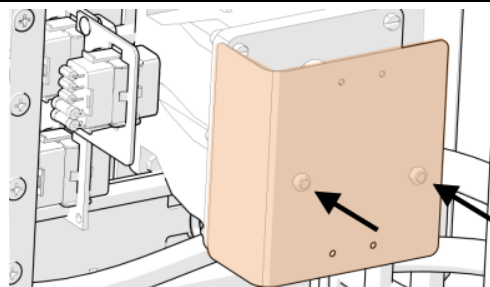

FIGURE 156

128. Place the **300A fuse #564520** in the fuse holder underneath the cable lugs.

129. Connect to the free post of the fuse holder the two (2) following cables that are routed from the alternator and the fan drive circuit breakers box:

- **Fan drive power cable #23498721**
- **L.H. alternator power cable #23498785**

A: nut #5001983 (2x)

B: washer #5001341 (2x)

Thread the nuts and tighten to a torque of 96 lbf-in (11Nm).

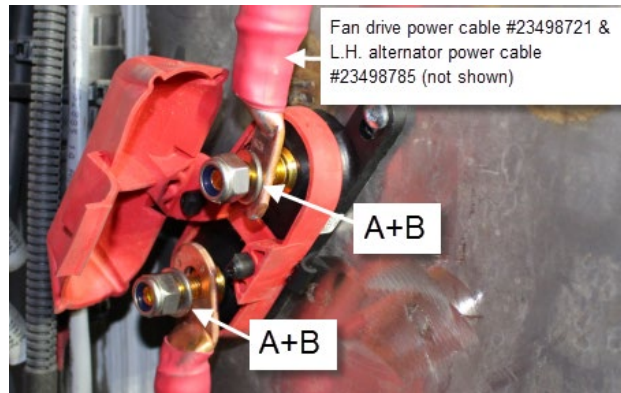

FIGURE 157: TAKE NOTE THAT THE 300A FUSE IS NOT SEEN ON THE PICTURE ABOVE BUT IT SHOULD BE INSTALLED AT THIS STEP

130. Secure the “fan drive power” cable and the “L.H. alternator power” cable as shown on the pictures at right using the following parts:

A: tie mount #509490 (2x)

B: rivet #504610 (2x) (hole diameter: Ø 17/64)

C: nylon tie #509491 (3x)

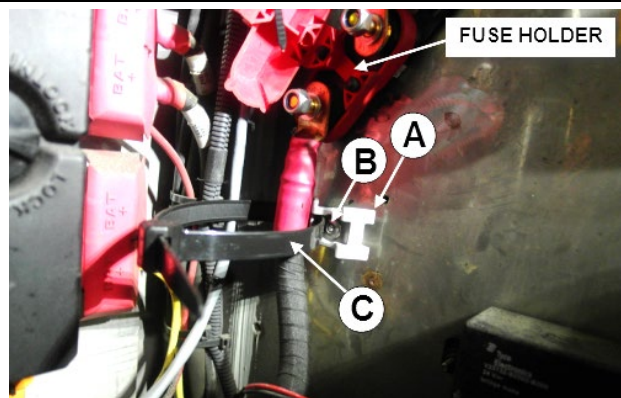

FIGURE 158

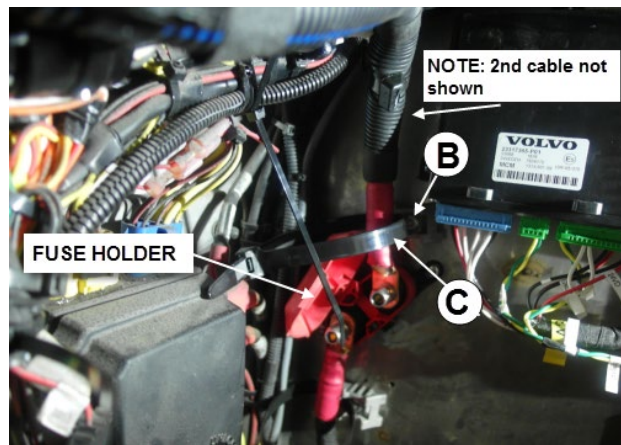

FIGURE 159

131. Install the MCM #23499009-EFD and the I/O-B module #22722850 on the bulkhead.

- Spacing between the I/O-B and the MCM=1 inch
- Pilot holes diameter: 11/64"

Install with the following hardware:

Tapping screws #500658,

3x for the MCM

4x for the I/O-B module

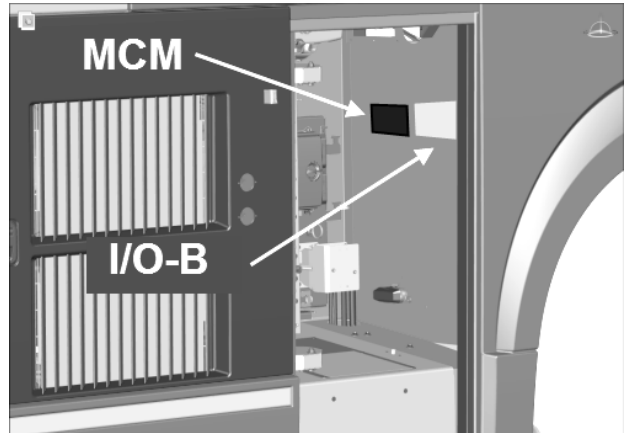

FIGURE 160: MAIN POWER COMPARTMENT

132. Depending on the coach configuration, an existing mounting plate may extend where the MCM should be installed and cause interference. If this mounting plate is useless, cut it off along the red line shown on the image.

IMPORTANT: Do not leave a sharp edge. Smooth down the edge.



FIGURE 161

133. In the main power compartment, connect the “fan to RJB interface harness” to the “MCM to I/O-B interface harness” #23445869 by means of connector C-EFD1.
134. Connect the MCM and the I/O-B module together using the “MCM to I/O-B interface harness” #23445869.
135. Connect the OEL resistors connector **RES1F** and **RES2F** (part #563593) to the “MCM to I/O-B interface harness”. See the image at right and the following pictures for reference.

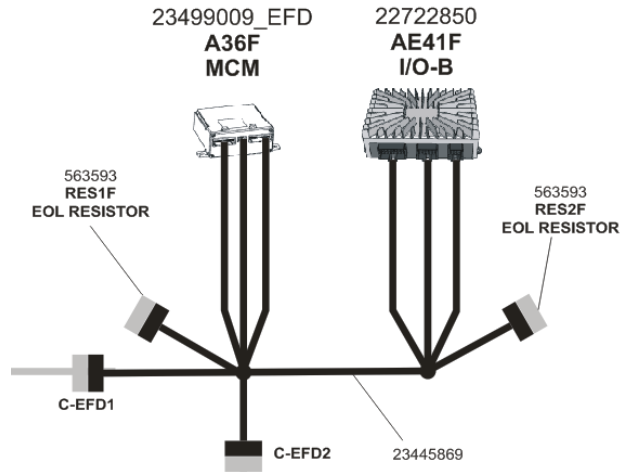

FIGURE 162



FIGURE 163

A: nylon tie #504016 (3x)

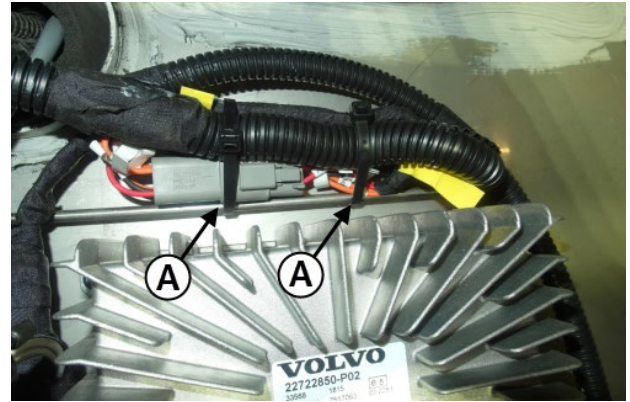

FIGURE 164

A: nylon tie #504016 (2x)

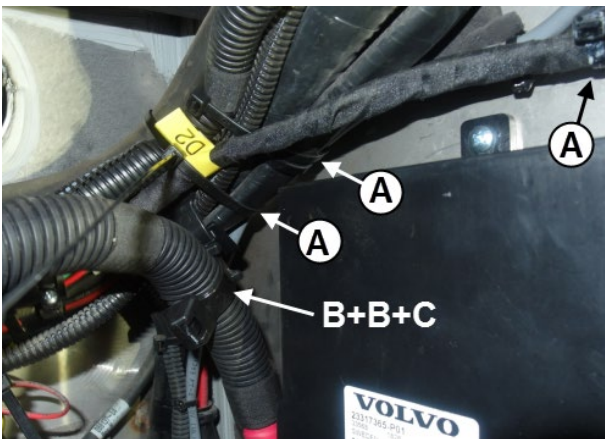

FIGURE 165

A: nylon tie #504016 (3x)

B: nylon tie #509491 (2x)

C: swivel mount #504751 (1x)



FIGURE 166

B: nylon tie #509491 (2x)

C: swivel mount #504751 (1x)

136. In the main power compartment, connect the “vehicle interface harness” #23490553 to the “MCM to I/O-B interface harness” by means of connector C-EFD2.

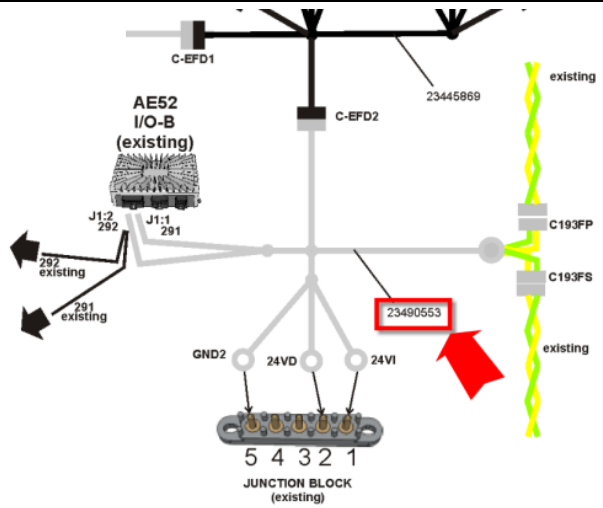

FIGURE 167

137. Connect circuit 24VI, 24VD & GND2 to post 1, 2 & 5 respectively of the junction block.

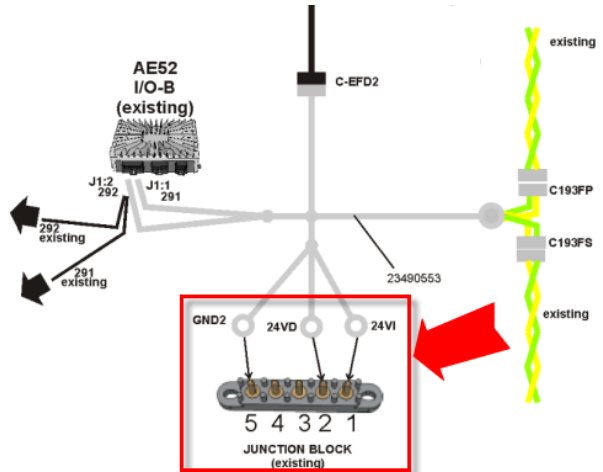

FIGURE 168

138. Get the J1939 signal. To do so, locate connector C193 among the existing harnesses of the main power compartment.
139. Disconnect connector C193 and connect with C193FS and C193FP of the “vehicle interface harness” #23490553.

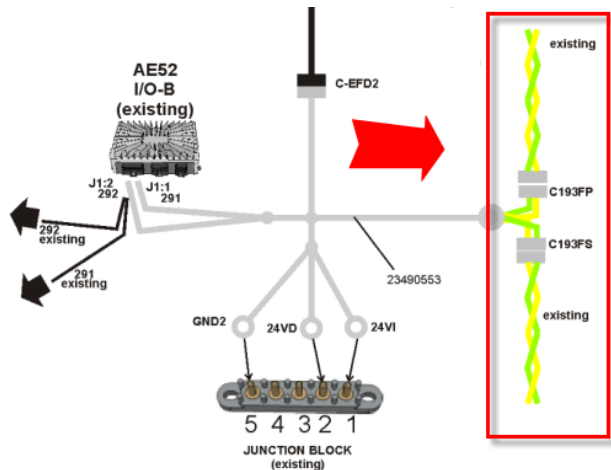

FIGURE 169

140. In the main power compartment, locate I/O-B module A52 (alternately named AE52).
141. At **A52** (or AE52), remove existing circuit 291 and 292 from connector J1:1 (pin 1) and J1:2 (pin 2).
142. For each circuit, cut the terminal and put a heat shrinking sleeve at the end of the wire. Those circuits won't be used anymore.
143. Insert circuit 291 and 292 of the **"vehicle interface harness" #23490553** into connector J1 pin 1 and J1 pin 2 respectively.

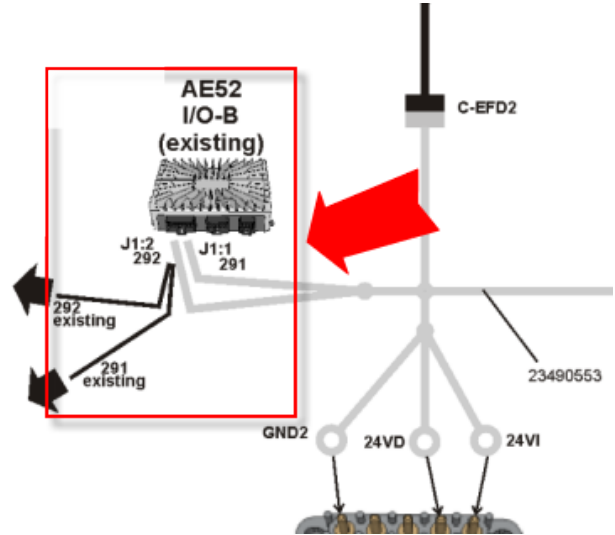

FIGURE 170

144. Install the U-shaped telltale light module bracket #381594 at an appropriate place in the electrical compartment where it can be reached by the **"fan to RJB interface"** harness. Fasten to the bulkhead using two (2) rivets #504379 (*hole diameter: Ø 13/64*).
145. Install two tab terminals #561540 on the 24V red telltale light module (#830165) wires.
146. Install the telltale light module in the telltale module bracket #381594. Using a P-Touch, make a label indicating "LH ALT".
147. Connect the appropriate branch of the "fan to RJB interface harness" to the telltale light module.

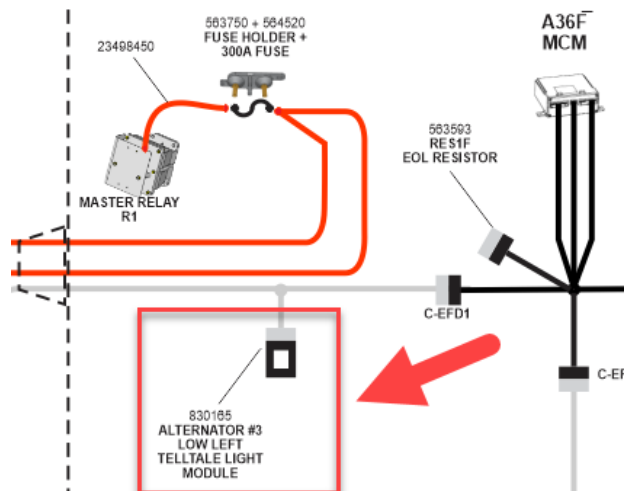

FIGURE 171

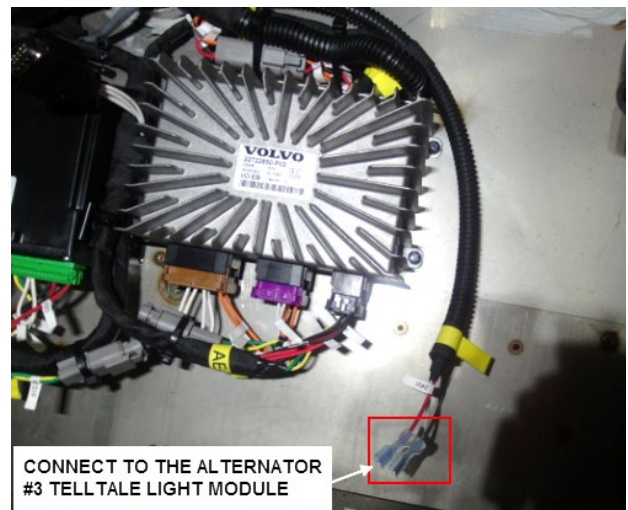

FIGURE 172

148. There are remaining nylon ties and tie mounts in the kit. Use them to secure the harnesses and cables that may seem loose. The goal is to prevent rubbing of the cables and harnesses.

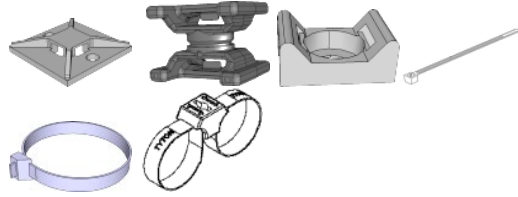

FIGURE 173

149. Place one (1) warning decal #069205 as shown on the image.

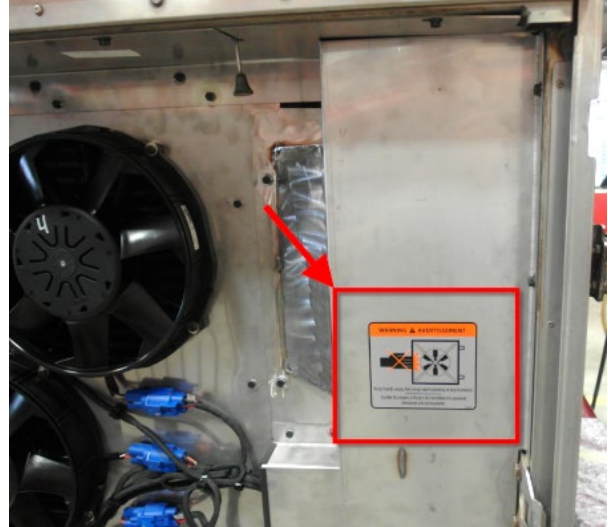

FIGURE 174

150. Install a second warning decal #069205 as shown on the radiator door.

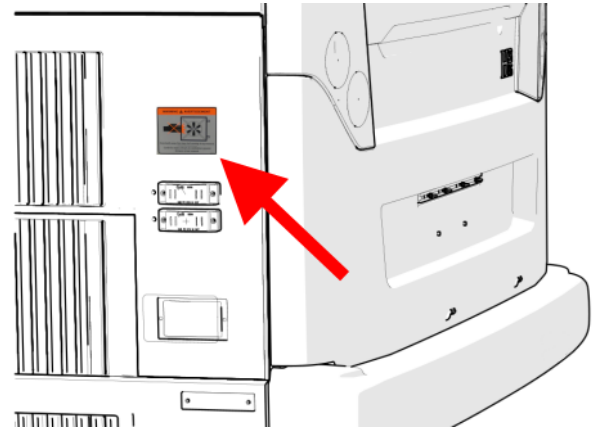

FIGURE 175

151. Fasten the radiator door **upper arm assembly**.

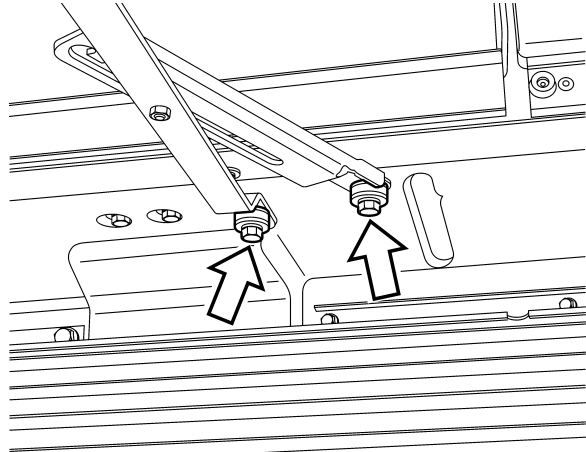

FIGURE 176

152. Refill the cooling system. Connect coolant extractor. Use coolant extractor to refill the coolant from the engine.

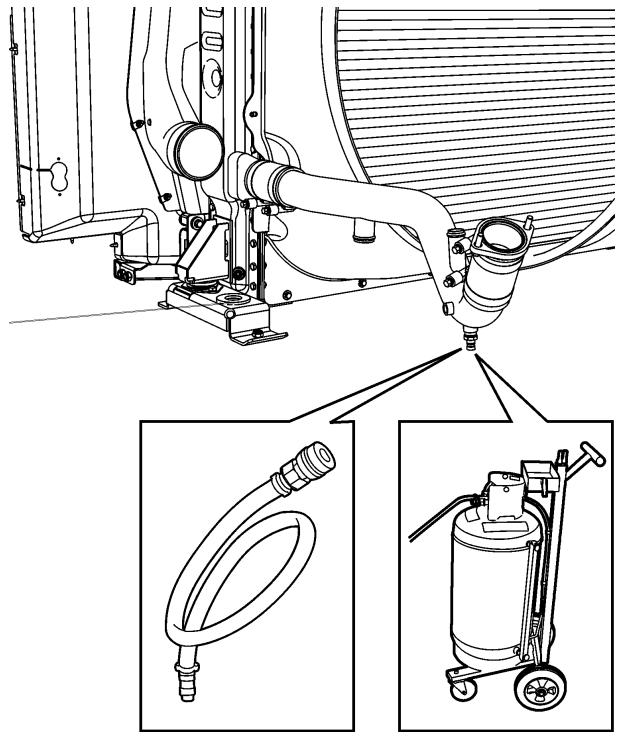

FIGURE 177

153. Reinstall the bumper.

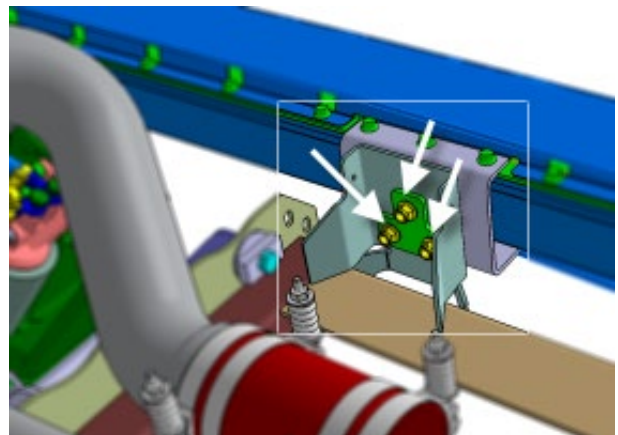

FIGURE 178

-
154. Reinstall the **access panel** located behind tag axle L.H. side wheel.

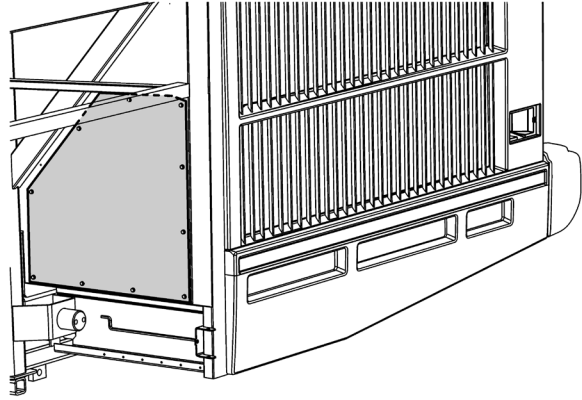

FIGURE 179

-
155. Reinstall the L.H. side **rear fender**.

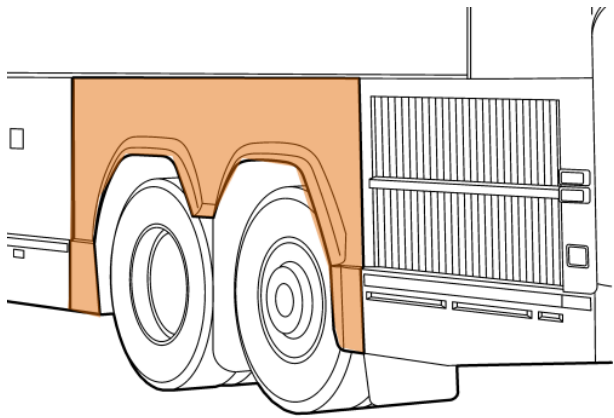

FIGURE 180

-
156. In the battery compartment, connect the battery ground cable to the chassis ground stud.

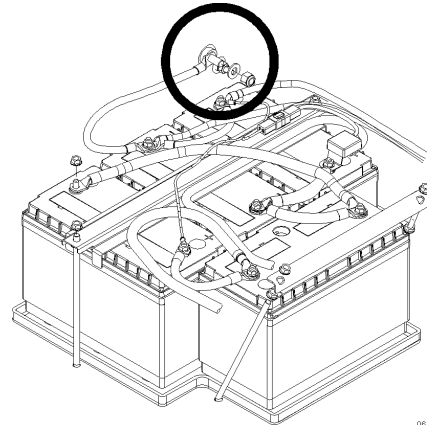

FIGURE 181

-
157. In the main power compartment, set the battery master switch to the ON position.
158. Set the ignition switch to the ON position.
159. In the main power compartment, reset the circuit breakers and wait two (2) minutes for the new installer I/O-B module to be programmed.
-

IMPORTANT NOTE

VEHICLES EQUIPPED WITH OPTIONAL PRIME ENERGY MANAGEMENT SYSTEM

TO PREVENT OVERLOADING THE L.H. SIDE ALTERNATOR, IT IS VERY IMPORTANT TO DISABLE « PRIME » SYSTEM ON VEHICLES RECEIVING THIS CONVERSION. PLEASE CONTACT YOUR NEAREST PREVOST SERVICE CENTER TO HAVE THE PRIME SYSTEM DISABLED. A SOFTWARE TOOL IS NEEDED TO DO SO.

SYSTEM TEST

160. Start the engine to idle.
161. With the engine in idle (600 rpm), use the Diagnostics menu of the Driver Information Display to engage the fans in speed 1.

Diagnostics > Vehicle Tests > Activate Radiator FAN Speed 1

The height (8) fans should run at 50% of the maximum speed. You need to evaluate the sound level and the power of the air stream to determine the speed.

162. Engage the fans in speed 2.

Diagnostics > Vehicle Tests > Activate Radiator FAN Speed 2

The eight (8) fans should run at 75% of the maximum speed.

163. Set the engine to the fast idle, the fans should then engage at 100% of the maximum speed.
164. If the fans behave in accordance with the criterions of the previous steps, then they operate normally.

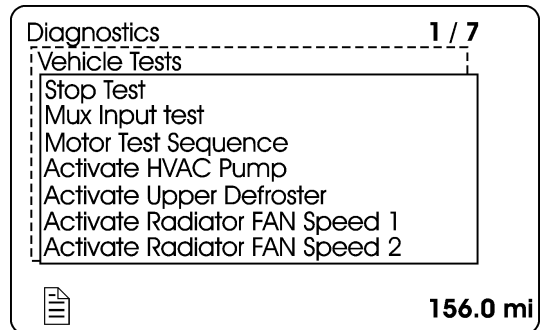

FIGURE 182

PARTS / WASTE DISPOSAL

Discard waste according to applicable environmental regulations (Municipal/State[Prov.]/Federal)

APPENDIX A

The following pages are available on the Prevest Technical Publications site under *Wiring Diagrams* tab.

X3-Electric Fan Drive conversion kit		Seated Coach X, Converted Coach Shell X	X3-45 X3-45 VIP X3-45 VIP Commercial Use X3-45 Commuter	2011 - 2019	Go to Diagram
H3-Electric Fan Drive conversion kit	B-1721 - K-0185	Seated Coach H, Converted Coach Shell H	H3-41 H3-41 VIP H3-45 H3-45 VIP	2011 - 2019	Go to Diagram

X3 Series:

<https://techpub.prevestcar.com/en/download?id=9074&type=wiring-diagrams-search-pages>

H3 Series:

<https://techpub.prevestcar.com/en/download?id=9073&type=wiring-diagrams-search-pages>



Wiring Schematic Aftermarket Electric Fan Drive kit

EFD H345 US10 to GHG17

EFD with Bosch Alternator KIT # IS19900

EFD with Remy Alternator KIT #IS19910

Apply to all H3 model from B-1721 up to K-0185

Dec 2018

Engine compartment component

Fan and shroud installation



Fan power BOX



Rear junction box components

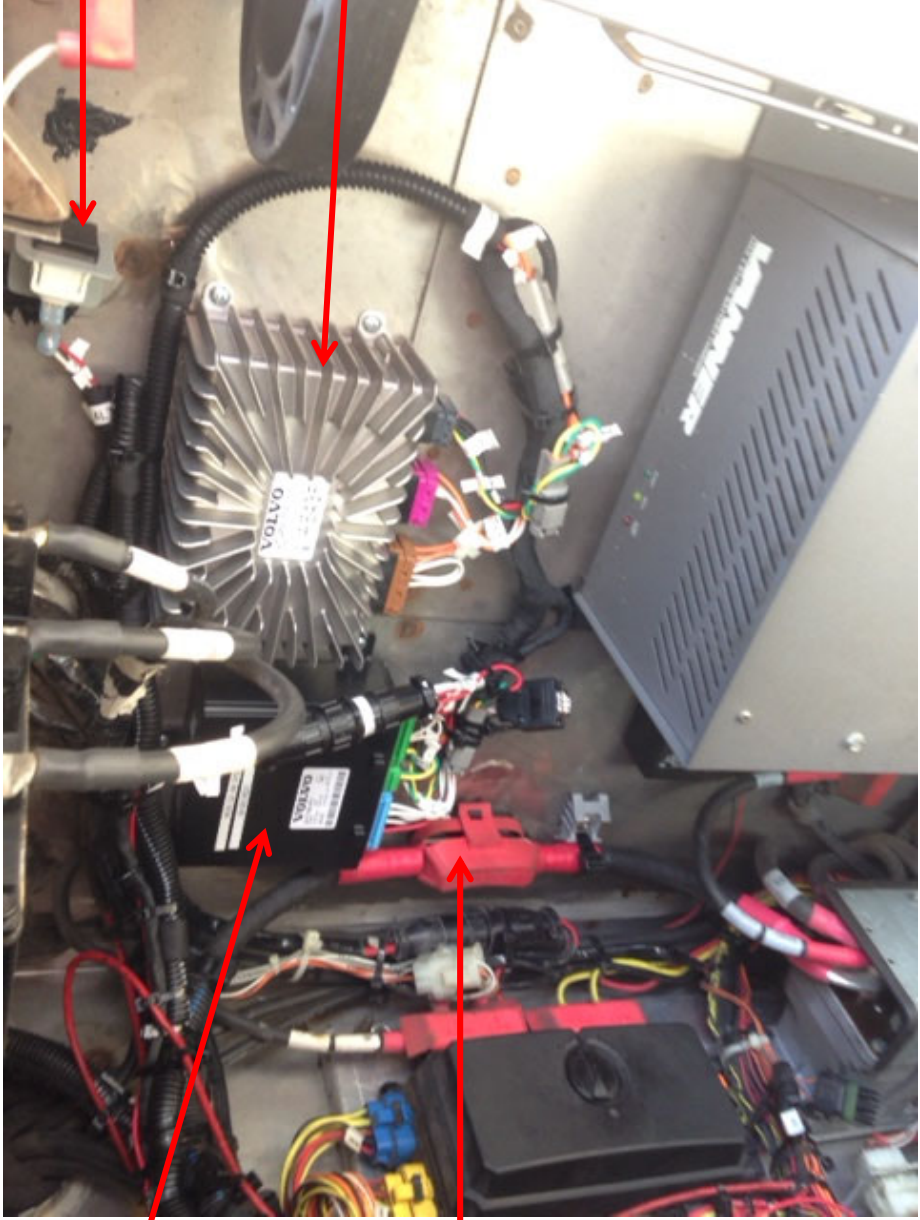

3rd alternator
light indicator

I-OEB module
AE41F

MCM 2.0
A36F

300A
fuse

WIRING HARNESS AND BATTERY CABLE

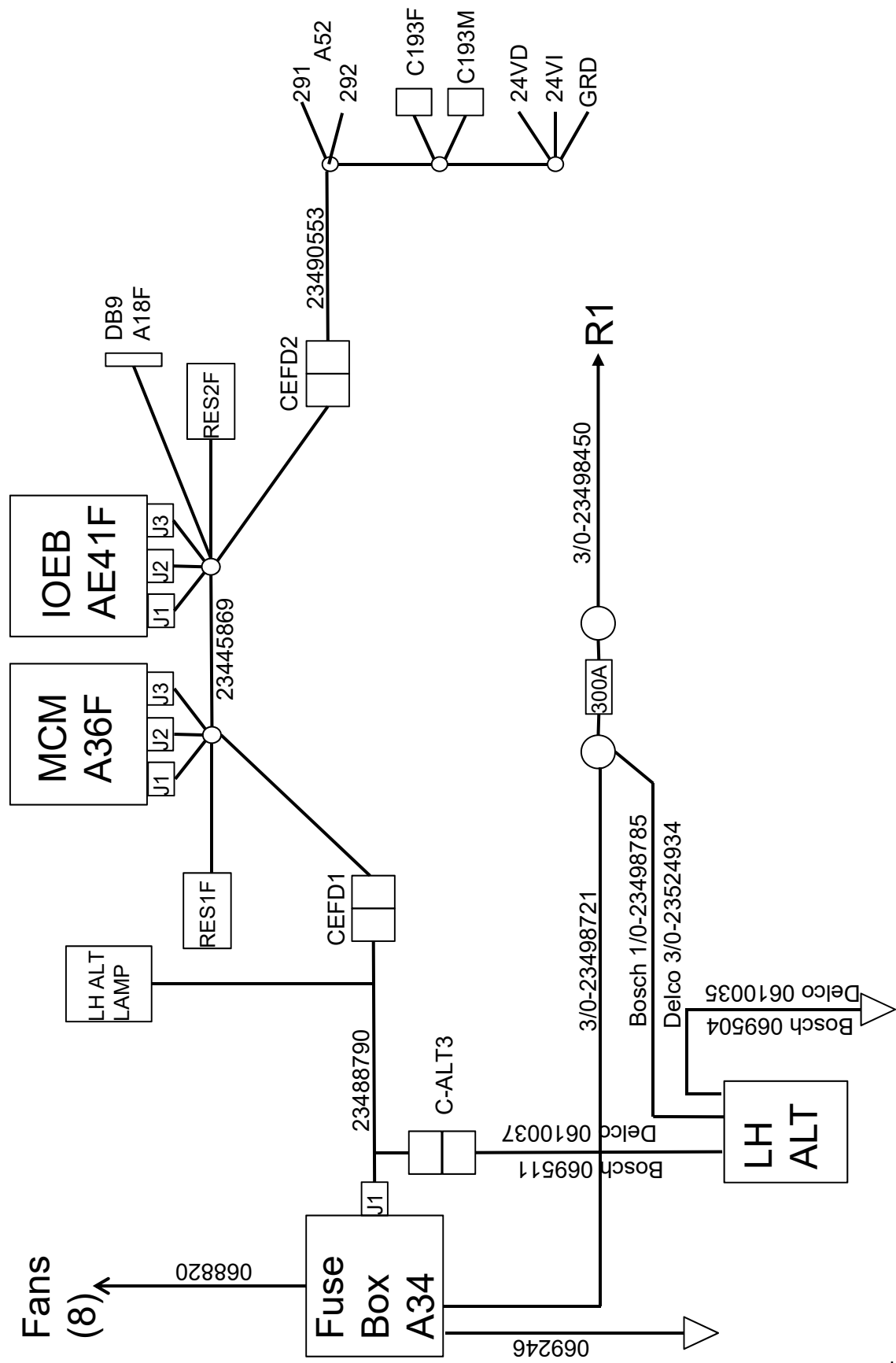

WIRING DIAGRAM MCM

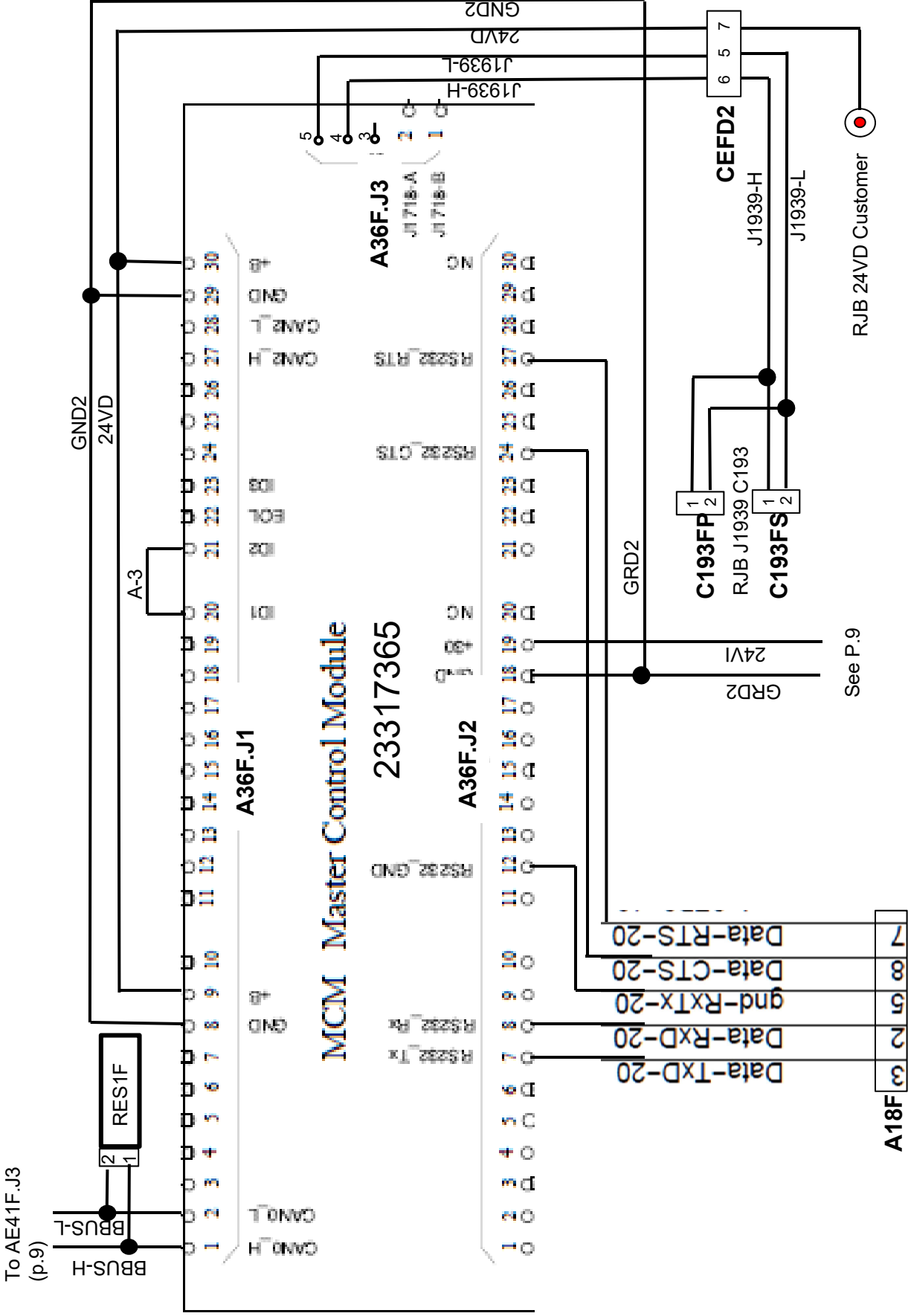

WIRING DIAGRAM I-O module

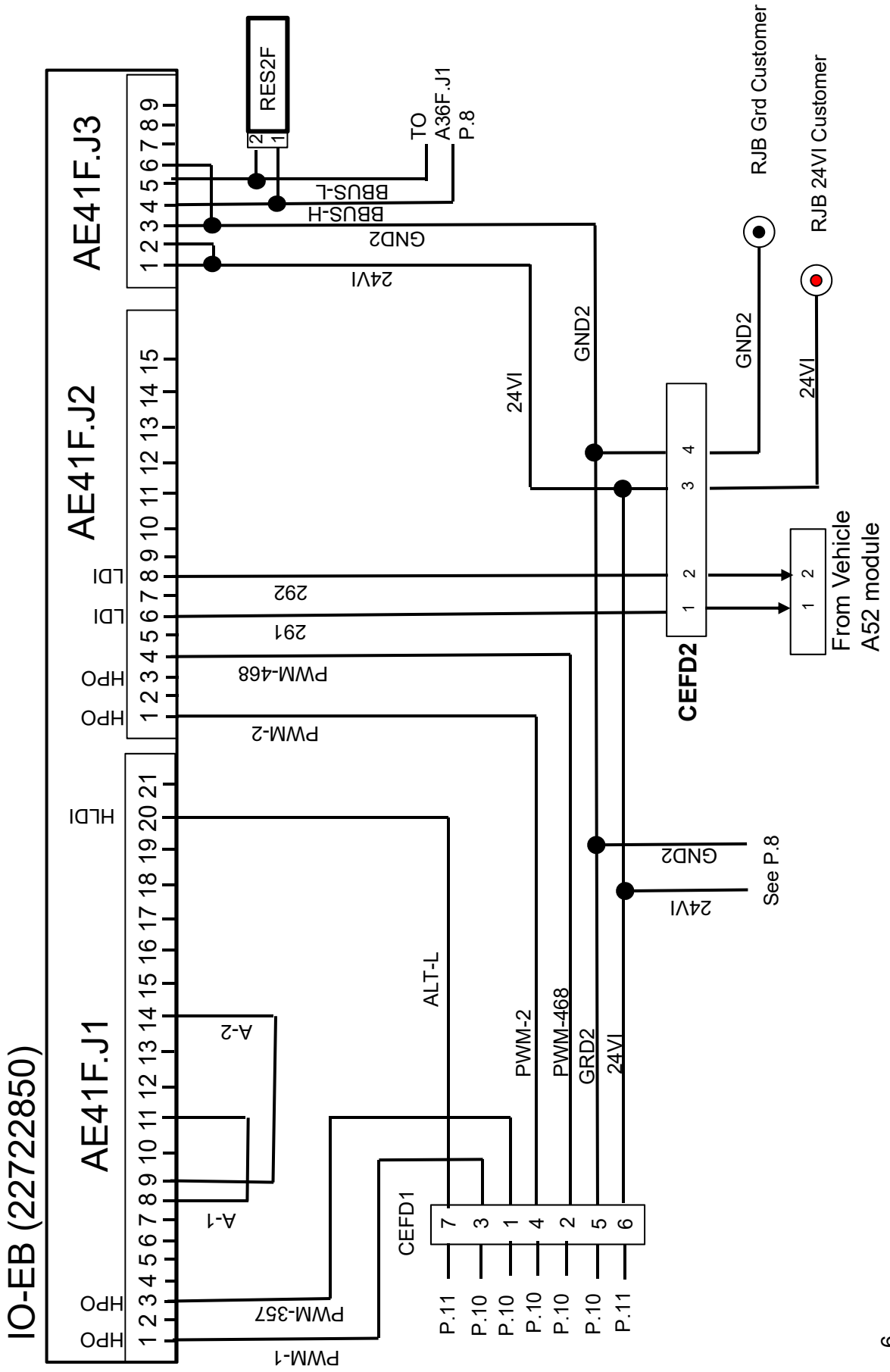

WIRING DIAGRAM FAN

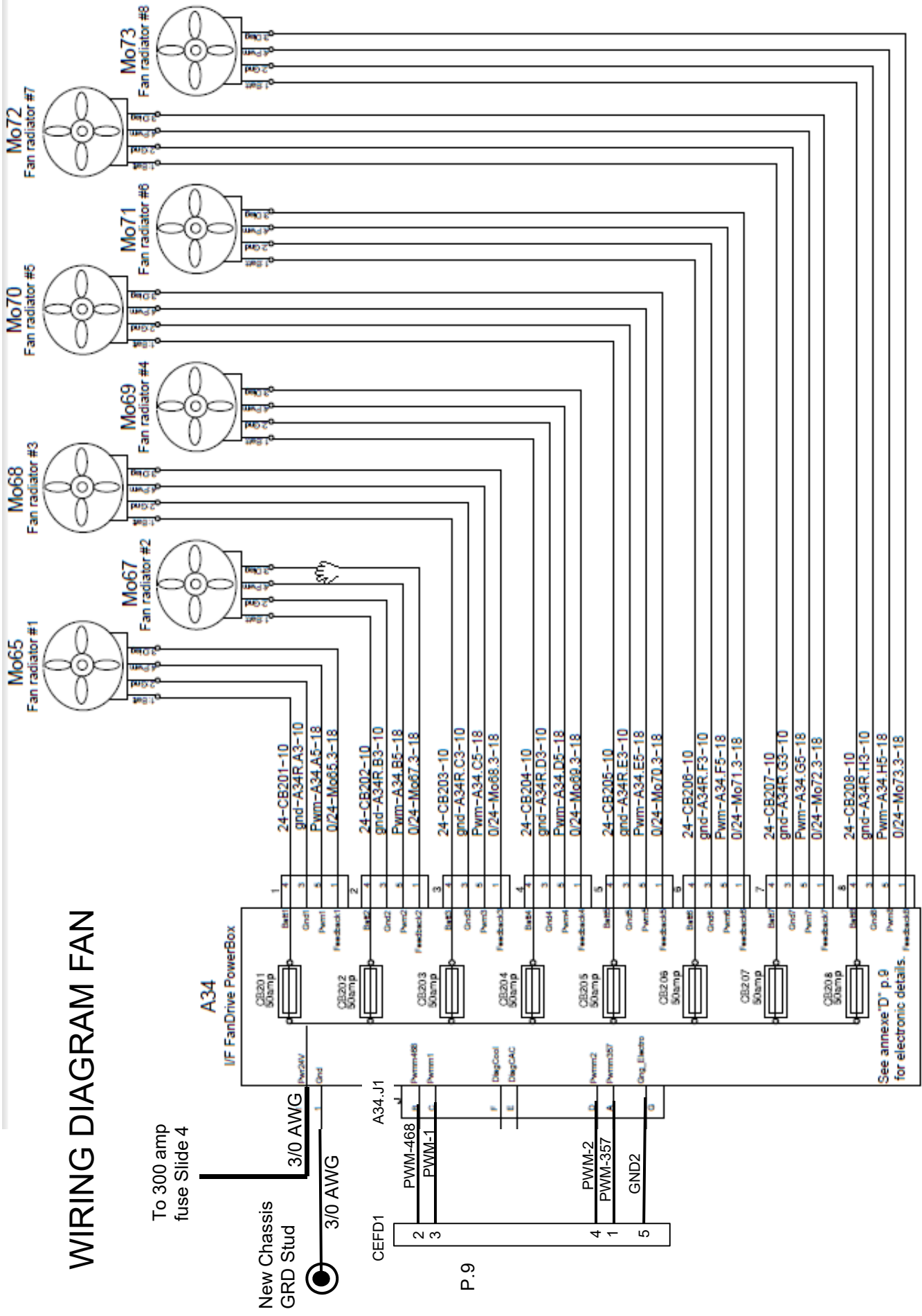

3RD BOSCH ALT WIRING DIAGRAM

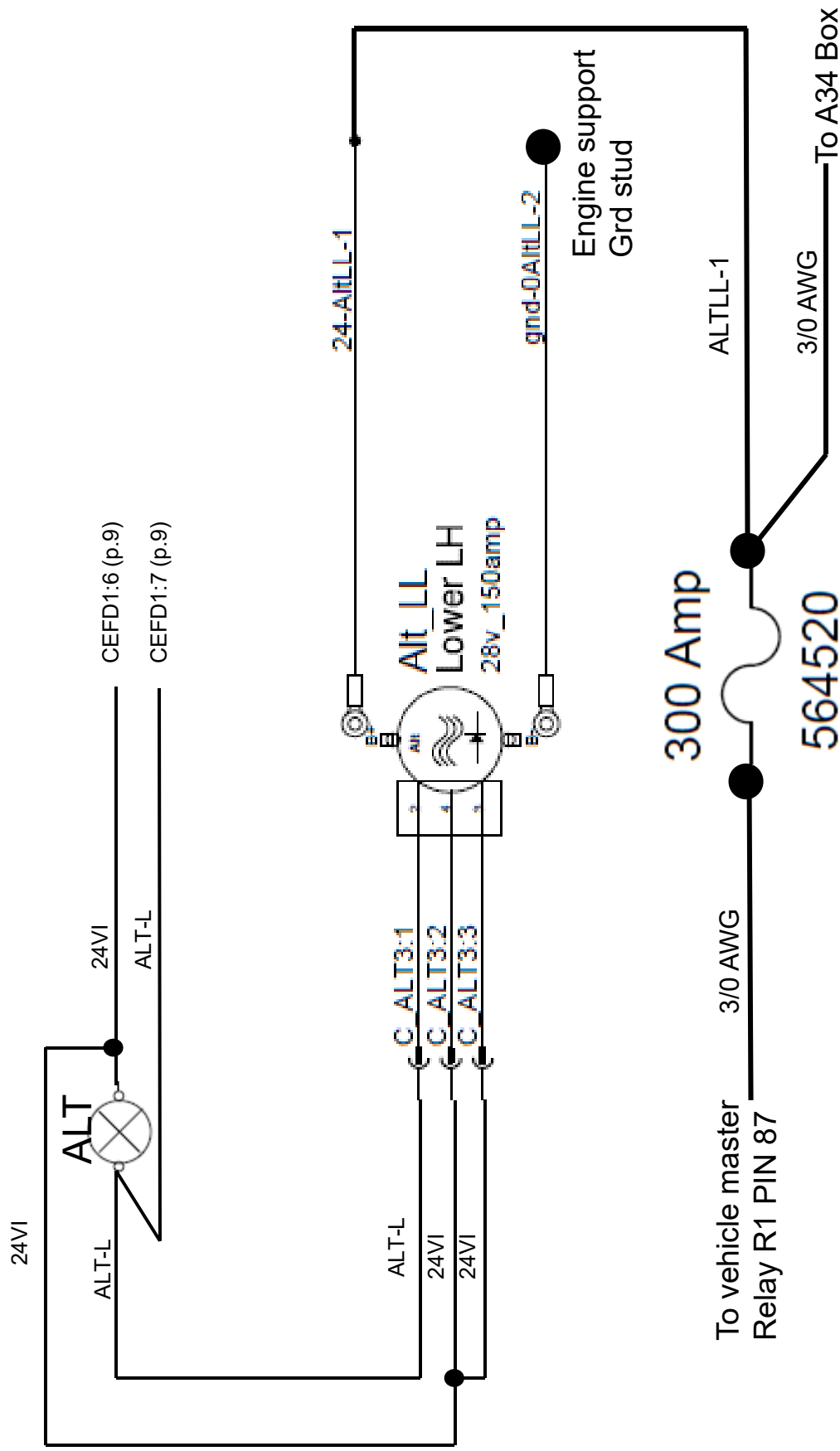

**THE ULTIMATE
EXPERIENCE**

PREVOST.

